

A-TRACK

USER GUIDE

RELEASE 2.2

CONTENTS

- 1 INTRODUCTION**
- 2 SYSTEM OVERVIEW**
- 3 GETTING STARTED**
 - 3.1 SOFTWARE SETUP**
 - 3.2 HARDWARE CONNECTION**
 - 3.3 OPERATING STATUS**
- 4 LOADING**
 - 4.1 INITIAL SEQUENCE**
 - 4.2 PROMPTS**
 - 4.3 ERROR HANDLING**
- 5 LIST SCREEN, CURSORS, KEYBOARD, AND MOUSE**
 - 5.1 GENERAL OPERATIONS**
 - 5.2 EMERGENCY STOPS**
 - 5.3 EDITING THE ITEM LIST**
 - 5.4 EDITING FILENAMES, TEXT STRINGS,
AND NUMERICAL VALUES**
 - 5.5 SCREEN SAVER - ATARI 'ATTRACT' MODE**
- 6 CONTROL SCREEN**
 - 6.1 OPERATION SETUP**
 - 6.2 ITEM ASSIGNMENT & CURSOR CONTROL**
 - 6.3 SPEED CONTROL**
 - 6.4 FUNCTIONS & ACCESSORY CONTROL**
 - 6.5 CONSISTS**
- 7 PROGRAM/VERIFY SCREEN**
 - 7.1 OPERATION SETUP**
 - 7.2 EDITING CONFIGURATION VARIABLES**
 - 7.3 ITEM TYPE & DESCRIPTION**
 - 7.4 PROGRAMMING A DECODER**
 - 7.5 VERIFYING DECODER CONFIGURATION VALUES**
 - 7.6 ACCESSORY CONFIGURATION VARIABLES**
 - 7.7 SETTING UP BLANK ITEMS**
 - 7.8 CONSISTS**
- 8 MENU**
- 9 PROGRAM CONFIGURATION**

- 10 TRACK OPERATIONS**
 - 10.1 CONNECTIONS**
 - 10.2 WIRING & OVERLOADS**
 - 10.2 PROGRAMMING DECODERS & CONSISTS**

- 11 HARDWARE OPTIONS & EXTENSIONS**
 - 11.1 PADDLE CONTROLLERS**
 - 11.2 A-TRACK HANDHELDS**
 - 11.3 POWER BOOSTER UNITS**

- 12 ATARI COMPUTER BASICS**
 - 12.1 DISK DRIVES AND OPERATIONS**
 - 12.2 ATARI DOS 2.5**
 - 12.3 ATARI ERROR CODES**

- 13 CHANGE HISTORY**
 - 13.1 RELEASE 2.0 (SINCE RELEASE 1.2)**
 - 13.2 RELEASE 2.2**

- 14 AFTERWORD**

DISCLAIMER

I hope you will like A-TRACK and enjoy using it as much as I have enjoyed creating it, BUT . . .

While every effort has been made to thoroughly test and verify all functions incorporated into the A-TRACK software and its associated hardware, please note that it is supplied on an "as is" basis and without warranty of any kind. You use the A-TRACK software and any associated hardware items at your own risk. The author and designer will not in any event be held liable for any improper operation of the A-TRACK system or interference with any other program or equipment, nor be held liable for any incidental or consequential damages of any sort arising out of its use.

Make back-up copies of all your important files
- BEFORE you start to use A-TRACK.

1 INTRODUCTION

A-TRACK is a program for the Atari XL/XE range of computers which implements the Digital Command Control (DCC) system for the operation of model railroads.

A-TRACK supports the full range of features defined in the DCC Standards and Recommended Practices issued by the National Model Railroad Association and, with the addition of a hardware interface box (the DCC Interface Unit, DIU) to link the computer to the track, will provide total control over a model railroad layout from your Atari computer keyboard. A-TRACK also supports the use of remote, handheld controllers which will let you operate up to eight locomotives on the track at the same time

DCC allows the simultaneous operation of almost any number of model locomotives on complex track layouts without the use of conventional block switching, ie. each locomotive does not have to be controlled within a single section of track allocated specifically to it. The speed and direction of each locomotive can be set independently regardless of where it is on the track (a feature, naturally, which has to be used with care!). Control can also be exercised over multiple locomotives treated as a single unit (MUs or consists) and over accessories such as lighting, signalling, and points (turnouts).

The basis of DCC is to supply power to the track in a form which also contains coded information to control the model locomotives and accessories. A fixed voltage (nominally 14 volts) is applied to the track. The voltage polarity is continuously reversed electronically between positive and negative such that the time periods between polarity reversals represent the required control data. A period of 58 microseconds positive followed by 58 microseconds negative represents a binary '1' bit, while consecutive positive and negative periods of 116 microseconds represent a binary '0' bit. Defined sequences of bits are used to represent commands to change speed, for example, and by how much, and to identify which locomotive should respond to each command.

Since the polarity of the applied voltage is positive and negative for equal lengths of time, the net voltage on the track, as seen by a normal (non-DCC) model locomotive, is zero (especially as the polarity reversals are occurring at around 6000 times a second) and the locomotive will remain stationary.

WARNING : While most model locomotive motors will not react to the DCC track voltage, other than by making a 'buzzing' noise, in some cases the motor will become very hot and can fail. It is recommended, therefore, that non-DCC locomotives are **NOT** placed on a track where DCC is in operation.

Unlike a normal model locomotive, a locomotive intended for DCC contains a decoder unit which performs two functions. The decoder picks up and rectifies the alternating voltage applied to the track and makes it available as a direct voltage which can be applied to the locomotive motor. The decoder also interprets the stream of bits encoded in the track polarity reversals as a set, or packet, of command bytes (a byte is a group of 8 bits) and acts upon them to apply an appropriate proportion of the rectified track power to the motor, making the locomotive move forward or backwards at the required speed. Each decoder is given a unique identity (or address) and will only act on command packets which have that address value encoded into them.

As well as controlling locomotive speed, decoders normally provide several auxiliary outputs which can be used to drive locomotive lights or sound units when activated by receipt of an appropriate command packet. Because power is always present on the track when using DCC, operation of these auxiliary functions is totally independent of the locomotive speed. Lights, for example, operate at constant brightness even when the locomotive is stationary.

There is provision within the DCC Standards to operate one conventional locomotive, not equipped with a decoder, on the track at the same time as the DCC-compatible locomotives. This is done by lengthening either the positive or negative part of a '0' bit cycle to give a net positive or negative voltage across the track rails, and thus drive the conventional locomotive forward or backward. However, the benefit of this feature is difficult to justify in view of the additional complexity required to implement it, and it is not incorporated in A-TRACK.

The same decoders fitted to locomotives can be used to control static trackside accessories such as signals and turnouts. However, specialised accessory decoders with multiple switched outputs are normally employed for this purpose unless, of course, the accessory (a turntable or crane, for example) requires control of an electric motor.

A-TRACK and the DIU are designed to be fully compliant with NMRA Standards and to work with all makes of commercial decoder. To date, the system has been successfully tested with Digitrax, Lenz, Model Rectifier, North Coast Engineering, Wangrow (System One), and ZTC decoders.

2 SYSTEM OVERVIEW

A-TRACK requires either an Atari 800XL or 130XE fitted with a disk drive for use as a Command (Base) Station (or Cab). The program requires only the basic 64K of memory so that any expanded memory can be used as a ramdisk if desired (see your Atari documentation for further explanation if necessary). Note that A-TRACK uses the sound capabilities of the Atari XL/XE to generate audible alarms in response to various errors or fault conditions which can occur. You should, therefore, ensure that the audio output of whatever monitor or TV set you are using for the display screen is set to a suitable volume.

The DIU receives command packets from the Atari XL/XE via a connection to the Parallel Bus Interface and translates the constituent command bytes into a series of positive/negative voltage transitions to be applied to the track. The track power, controlled through the DIU, is derived from a separate transformer supplying 15 volts AC to the DIU at a maximum current of 4 amps. Where this amount of power is inadequate to supply all of the locomotives and accessories that you want to operate simultaneously on the track, the layout can be divided into several electrically-isolated sections, often referred to as 'power districts'. One section (or district) is driven from the DIU, and each of the others will be driven by a slave Power Booster Unit (PBU). Each PBU has its own 15 VAC 4A transformer and receives the stream of bits forming the DCC command packets from the DIU, converting them into the required voltage transitions. Because the DIU and all PBUs are synchronised, locomotives can travel between layout sections without any restrictions, and without any interruption of control.

A-TRACK works with a software list of Controlled Items where each Item contains a description and operational parameters for one of the locomotives, consists, or accessories to be controlled on the model railroad layout. The user can view the Item List and select any individual Item in order to control it or to amend its operational parameters. Item Lists are loaded from disk and, when updated, can be saved back to disk for future use. This ability is a major advantage of A-TRACK over current commercial DCC systems, where the operating characteristics of your locomotives are stored within the equipment itself, and there is generally no provision for maintaining a back-up copy of all the parameters.

Each Item List may contain a maximum of 64 Items but, by use of the editing facilities in A-TRACK, Items can be added or deleted from one Item List and moved to another, for example, to give you the right set of Items you need for a particular operating session, or simply reordered for more convenient access.

Selection and control of an Item is performed using either the computer keyboard or a mouse (or a combination of both). The various screen displays show the results of any action and the current state of the selected Item(s). A-TRACK uses its own character font to improve readability and to allow the use of several special characters in the displays.

While Items can be directly controlled from the computer (Base Station) the normal mode of operation will be to use the Base Station as a "dispatcher", and allocate an Item to one of several Handheld Controllers (Remote Cabs) connected to the A-TRACK system via the Atari XL/XE Joystick Port 2. This allows multiple users to control selected Items independently of (and at the same time as) each other, and of the central operator (or dispatcher) at the computer keyboard.

As mentioned previously, before any Item can be controlled, its decoder must be given a unique identity (address) so that it will respond only to those commands directed specifically towards it. This is done by sending a special set of programming commands to

the Item on its own (usually on an isolated section of track). A-TRACK provides all of the necessary programming facilities from the Base Station, and allows the full range of decoder parameters (known as Configuration Variables or CVs) defined in the DCC standards, as well as the Item address, to be set up, verified, and amended as required. This is dealt with fully in Sections 7 and 10.

3 GETTING STARTED

3.1 SOFTWARE SETUP

This User Guide assumes that you are familiar with the normal operation of an Atari XL/XE computer, and with reading and writing files to and from a disk drive. You will still be able to use A-TRACK without this knowledge, but may find some of the descriptions and explanations a little difficult to follow. Refer to your Atari computer documentation for guidance on basic operating procedures - a summary of the sequences which may be required during A-TRACK operation can be found in Section 12 towards the end of the User Guide.

A-TRACK will operate with either the Atari DOS 2.5 disk operating system (or any of its derivatives) or with SpartaDOS. Since the program makes only legal calls to the inbuilt (ROM) operating system and to DOS, it should work with any other DOS (such as MyDOS, for example) without any problems, providing the DOS does not occupy too much of the computer's memory space. The address of the bottom of free memory (MEMLO) must be kept below \$1F00 (hexadecimal, 7936 decimal) - the address at which the A-TRACK program loads.

A-TRACK is written entirely in Assembler (machine code) since BASIC would be far too slow to handle the generation and output of DCC commands in real time. The program also uses all of the machine's available memory (from \$1F00 to \$BFFF) including that normally occupied by the built-in XL/XE BASIC language interpreter.

The A-TRACK Master disk contains a complete set of files necessary to load and run the program, and to demonstrate its various features and operating modes. Side A contains the files in DOS 2.5 format (and a copy of DOS 2.5XL which loads the **DUP.SYS** file into the RAM under the OS ROM) and Side B holds the same files formatted under SpartaDOS 3.2d. Ensure that both write-disable tabs are present on the Master disk (covering the notches on the edges), then copy the files you need to use to a Working disk before attempting to run A-TRACK. (See Section 12 if you are in doubt about what to do). The Working disk should already have been formatted by, and contain, whatever variety of DOS you wish to use. Store the Master disk away in a safe place (and well away from the magnetic fields of power transformers and locomotive motors!).

The minimum set of files A-TRACK expects to find present on Drive D1: for correct program load and initialisation is -

ATRACK.COM System Initialisation and Loader
ATRACK.OVL Main A-TRACK Program (Overlays part of Loader)
ATRACK.CFG Configuration Parameters
ATRACK.FNT Text & Special Character Font

If you are using Atari DOS 2.5 then rename **ATRACK.COM** to **AUTORUN.SYS** in order to allow A-TRACK to load automatically when the system is booted. Alternatively, you may load and run **ATRACK.COM** manually using the DOS Menu 'L' function.

If using SpartaDOS, copy **STARTUP.BAT** to the Working disk as well. This gives you a minimal start-up file containing the following commands -

DATE
TIME
BASIC OFF
ATRACK

Entering today's date and time at the **DATE** and **TIME** prompts is only necessary if you wish to have an accurate time-stamp on any files you make changes to, then save (such as Item Lists or the system Configuration) - but it has no other effect on the operation of A-TRACK at all. You can expand on this simple start-up batch file if you wish, to add a ramdisk, for example, but do not add any utility which takes MEMLO above \$1F00. Do **NOT** use the time/date display utility **TDLINE.COM**, since its use of interrupts, etc., will clash with A-TRACK.

On first loading, A-TRACK is configured to prompt you to load a demonstration Item List, **ATRKDEMO.ITL**, so that this file should also be copied to the Working disk.

3.2 HARDWARE CONNECTION

The DCC Interface Unit (DIU) has the minimum of controls - two switches located on its front panel, Power On/Off to the left and Operate/Program Mode Select to the right - plus three LEDs to indicate its current status (Power On, DCC Packets Active, and Output Current Overload). Connections to the DIU are made via the 50-way Parallel Bus Connector on its front panel, the 7-pin and 5-pin DIN Sockets on right- and left-hand side panels, and a set of terminal posts mounted on the rear panel.

The DIU rear panel has three pairs of terminals -

Blue	15 Volts AC Transformer Input
Yellow	Output to Programming Track (250mA Max Current)
Green	Output to Main Track (4 Amps Max Current)

- and two monitoring points -

Red	+14 Volts DC (Track Power)
Black	Track Power Ground (0V)

The DIU is supplied with two connecting leads - a 7-pin DIN to 7-pin DIN (straight-through) power lead, and a 50-way ribbon cable (PCB edge connector to IDC header). The latter is designed to be connected to the Atari 800XL Parallel Bus Interface (PBI) port. An alternative 50-way cable, or an adaptor, is necessary to allow connection to the Enhanced Cartridge Interface (ECI) of the Atari 130XE.

The DIU takes power for its logic circuitry from the Atari XL/XE Power Supply Unit. Hence, with your Atari XL/XE computer, its disk drive, and the DIU all switched off, unplug the power-in connector from the rear of the Atari XL/XE and plug it into one of the 7-pin DIN power sockets on the left side of the DIU (either can be used). Now connect the power lead supplied with the DIU from the other 7-pin socket to the vacated power-in socket at the rear of the Atari XL/XE.

Next, using the 50-way ribbon cable supplied, connect the DIU to the PBI (or ECI) port at the rear of the Atari XL/XE computer. Note that the connector which plugs into the DIU is polarised (a 'bump' at top centre), so that it can only be inserted one way. The ribbon cable

should then be kept flat, and not twisted, from the DIU to where it plugs into the computer port. The ribbon cable can be bent or folded to position the DIU at a convenient position above and behind the Atari XL/XE so that its switches are accessible.

At this stage it is desirable, although not essential, to connect a 15 volt AC supply, of up to 4 amps capacity, to the appropriate (Blue) terminals on the DIU rear panel. This powers the DIU output circuitry supplying DCC-compatible power and control signals to the track. If the 15VAC supply is not present, its absence will prevent some DIU functions from operating correctly, and this will be reported at the appropriate time as an error by the A-TRACK software (see Section 3.3 below).

IMPORTANT NOTES & WARNINGS :

- (1) The DCC Output power is totally isolated from the 5-volt logic power derived from the Atari XL/XE in order to prevent any damage to the DIU or Atari XL/XE circuitry from inductive voltage spikes generated by locomotives or other items connected to the track. The metal case of the DIU (or PBU) is connected electrically to the ground (GND or 0V) of the Atari XL/XE. The Power Ground (Black) monitoring terminal on the rear panel **MUST NOT**, under any circumstances, be connected to the DIU case, or to any ground (GND or 0V) connections of the Atari XL/XE or any of its peripherals.
- (2) Since, as explained in the Introduction, DCC functions by alternating the polarity of the track output terminals, there **MUST NOT** be **ANY** connections made between the Power Ground or +14V DC monitoring terminals and any of the Main or Programming Track terminals, or to any part of the track itself. Failure to observe this restriction will lead to the destruction of the DIU or PBU power output electronics.

For now, until you become completely familiar with the operation of A-TRACK, do not connect any of the DIU output terminals (Yellow or Green) to any section of track. You should also ignore the 5-pin DIN sockets on either side of the DIU. These are used to connect the DIU to auxiliary Power Booster Units (or to other DIUs configured as slave units) and to supply power to a Network Driver unit used in conjunction with a set of Handheld Controllers, and such operation will be dealt with fully in Section 11.

3.3 OPERATING STATUS

As described in Section 3.1 above, the front panel of the DIU has three LED indicators to show the status of the hardware.

The Yellow LED next to the Power On/Off switch shows that power is available to the DIU from the external 15 VAC transformer (It is assumed that +5V DC power to the logic circuitry is present if the Atari XL/XE is operational, and the DIU Power switch is On).

The Green LED labelled '**ACTIVE**' indicates that the DIU is functioning and that DCC data/commands are being passed to the DIU power output stages.

The Red LED labelled '**OVERLOAD**' shows when the maximum output current for the selected mode (Operate or Program) has been exceeded. Once an overload has been detected, and the Red LED lit, the DIU reduces the output voltage to limit the track current to a safe value. Removing the cause of the overload from the track may allow the DIU to recover on its own (if the remaining load is sufficiently low) - otherwise it will be necessary switch the DIU off briefly, then back on, to resume normal operation.

As well as displaying its immediate status on the LED indicators, the DIU also provides status information to the Atari XL/XE for use by the A-TRACK software. In response to this data, A-TRACK may display one of a number of DIU-specific error codes on the Status Row of the computer screen (see Section 4 below). These specific error codes comprise -

- 201 Unable to Generate DCC Command
- 202 Invalid Data Entered
- 203 DIU Not Enabled
- 204 DIU/PBU Not Active
- 205 DCC Command Block Not Output
- 206 DIU Not in Program Mode

4 LOADING

4.1 INITIAL SEQUENCE

Having connected the DIU to the Atari XL/XE as described in the preceding Section, set the Mode Select switch to Operate, and switch the DIU On. Assuming that the external 15 VAC supply is connected, the Power LED should light, the Active LED will light momentarily and then, like the Overload LED, should remain dark.

Before loading the A-TRACK program, ensure that all plug-in cartridges are removed from the Atari XL/XE. Switch on disk drive D1:, insert your Working disk into the drive, and switch on the Atari XL/XE. It is not necessary to disable the internal BASIC by holding down the **OPTION** key during switch-on, since the A-TRACK loader will do this automatically. Note that the **BASIC OFF** command in the **STARTUP.BAT** file is only there to tell SpartaDOS that the internal BASIC has been disabled, since it cannot, apparently, figure this out for itself.

If you are using Atari DOS 2.5, and have renamed **ATRACK.COM** to **AUTORUN.SYS** on your Working disk, then A-TRACK will load automatically. Otherwise you can load the program manually from DOS by typing 'DOS' at the 'READY' prompt, then selecting option 'L'. Type '**ATRACK.COM**' as the program to load and press the **RETURN** key.

Using SpartaDOS 3.2 with a **STARTUP.BAT** file as described should also load ATRACK automatically, but you can load it manually from the 'D1:' prompt by typing '**BASIC OFF** [RETURN]' followed by '**ATRACK** [RETURN]'.

The A-TRACK Loader will display an initial banner on the screen while it loads the main A-TRACK program. Any errors which might occur during the loading phase are reported on-screen using the normal Atari error codes. If an error does occur, you then have the option to restart the boot process by pressing the **RETURN** key, or to return to DOS by pressing **BREAK**.

After a successful load A-TRACK displays its operational screen format where the screen is divided into a number of areas, each with their own function, and each consisting of one or more screen rows.

The top two rows form the Menu Area which (as you might surmise) is used to display a series of menus providing access to most of the program's functions. After initialisation, the Menu Area just shows the program name, description, and version number (Black text on a White background). Below this is the single row of the Title Area (White text on a Blue background) which will be used to display captions relating to the Item data shown below it in the following 20 screen rows of the List Area (Green text on a Black background).

At this point the List Area shows the A-TRACK banner, and the Title Row shows '**No Item List Loaded**' together with, towards the right of the screen, three characters ('N', 'o', and '↑') representing the status of the following program parameters -

Operating Mode

- N** = None - Idle state, No Commands can be output
- DIU may be in either Operate or Program Mode
- C** = Control - Commands can be sent to control Items
- DIU should be in Operate Mode, driving the Main Track
- P** = Program - Commands can be sent to program Decoders fitted in Items
- DIU should be in Program Mode, driving the Programming Track
- V** = Verify - Commands can be sent to verify Decoder CV values
- DIU should be in Program Mode, driving the Programming Track

The Operating Mode can be set explicitly by use of the Menu (see Section 8 later), or automatically by invoking an appropriate action in A-TRACK, as described in later Sections of this User Guide.

Text Edit Mode

- o** = Overwrite - Typed character replaces character under cursor
- i** = Insert - Typed character is inserted into string at the cursor position, and existing characters to the right of the cursor move one place right

The state of Text Edit Mode is only relevant when editing strings of text or numbers on the Status Row (see below) and has no effect on keystrokes in other parts of the program. When editing a text string the state of Text Edit Mode is toggled (changed to the other state) by pressing the **INSERT (SHIFT->)** key.

Text Case

- ↑** = Upper case letter entry
- ↓** = Lower case letter entry

Like Text Edit Mode, Text Case is only relevant when editing text strings and has no effect on keystrokes in other parts of the program, where the case of a letter key is disregarded. The state of Text Case is toggled by pressing the **CAPS** key when editing text. Note that, in either state, holding down the **SHIFT** key allows you to enter letters in the opposite case. Use of **CAPS** has no effect on the number, punctuation, symbol, or function keys. **SHIFT** or **CONTROL** is used with these keys to produce the relevant shifted character or control function without reference to the state of Text Case (but see the note in Section 5.1 below regarding the use of the Arrow keys).

If an appropriate mouse was plugged into Joystick Port 1 (on the right-hand side of the computer) before the Atari XL/XE was switched on, you will note the appearance of the Mouse Cursor (a Mauve arrow) towards the bottom left corner of the List Area. When A-TRACK is performing some function which takes an appreciable time to execute, the Mouse Cursor will change to an hourglass shape as an indication that you should wait for the function to be completed.

Finally, on the bottom screen row, the Status Area (Black text on a Yellow background) is used to display messages and prompts to the user, and is where you will enter text and data values to A-TRACK when necessary. When error messages or alarms are displayed the Status Area colours change to Black text on a Red background.

4.2 PROMPTS

After program load a prompt is displayed on the Status Row, offering you the opportunity to load the demonstration Item List, **ATRKDEMO.ITL**. The file name can be changed, as described in Section 5.4, to allow the loading of any other Item List but, for now, just press the **RETURN** key to load **ATRKDEMO**, and the banner will be replaced with a display of the first 20 Items from the Item List. Do not be alarmed at the temporary disappearance of the colours of the various Screen Areas as the load proceeds. This is a quirk of the way in which the Atari XL/XE computers handle their input/output processes.

For this first example, with no connection from the DIU to the track, answer the next three prompts shown on the Status Row by pressing the **N** key.

The first prompt (to Clear Decoders) allows you to broadcast a Soft Reset command to all Items on the track, if required, setting the speed of locos and consists to zero and switching off all decoder function outputs. By pressing **N** as suggested, A-TRACK will only output Idle command packets instead of Reset packets.

The next prompt offers you the opportunity to restore the Speed parameters possessed by Items at the time the Item List was last saved to disk. Such a restoration has to be done with care, obviously, since commands will be issued immediately to all locos or consists, setting them to run at their saved speed values. A similar operation offered by the third prompt, to restore Function parameters, can be particularly useful where turnouts are controlled by accessory decoders and you wish to issue commands to set them all to a known (saved) position. The demonstration Item List, **ATRKDEMO.ITL**, does not contain any saved parameters so that pressing the **Y** key in response to the prompts, in this case, will not cause any problems.

The fourth (and final) prompt, asking you to confirm that the DIU is set to Operate Mode, appears at this point only if you answer **N** to the Clear Decoders prompt - otherwise it appears as the second prompt in the sequence. It should be answered by pressing the **Y** key, after checking that the Mode Switch is in the correct position. You will find that this particular prompt is displayed fairly frequently during A-TRACK operation, whenever the program wishes to output a fresh set of command packets, and has any reason to expect that the DIU Mode Switch might have been changed to Program Mode. After pressing **Y**, note that the Operating Mode indicator on the Title Row changes from '**N**' to '**C**', signifying Control Mode.

If the DIU is operating correctly (with or without its external 15 VAC supply connected), pressing **Y** should also result (finally) in the message '**Status: OK - 00 Commands Active**' being displayed on the Status Row. If the 15 VAC supply is present then the Green Active LED should also light in response to the Idle command packets which are now being output by the DIU to its Main Track terminals.

4.3 ERROR HANDLING

If the DIU or the Atari XL/XE detects some fault during the above (or subsequent) sequence of events (such as the DIU not being connected) it will be reported as an error at this point. The error code (or an explanation) will be displayed (as Black Text on Red) on the Status Row, and a 'beep' will sound to attract your attention. The error display is cleared by pressing either the Escape (**ESC**) key or the Right Mouse Button (RMB), after which you will be given the opportunity to ignore further DIU error and status reports by answering **Y** to the next prompt 'Ignore Further DIU Status/Errors?'.

BE WARNED that, if you decline the invitation to ignore errors at this point in the program, by pressing the **N** key, it is likely that the next time the DIU reports a status error you will be presented with a continual stream of error messages on the Status Row. Switching everything off and restarting may then be the only option available.

For demonstration purposes, ignoring DIU errors and status is acceptable, but the situation should not occur during real operation when connected to the track. If the query does appear in this situation, then you will need to check carefully that all parts of the system are connected and/or set up correctly (as described in Section 10), answer **N** to the prompt, and try again. Choosing to ignore DIU status will prevent command packets being output correctly, and control of any locomotives or accessories will be lost.

5 LIST SCREEN, CURSORS, KEYBOARD, AND MOUSE

5.1 GENERAL OPERATIONS

A-TRACK can be operated entirely through the keyboard, but also offers the option of using a mouse. Either an Atari ST or Commodore Amiga mouse can be used, plugged into Joystick Port 1 on the right-hand side of the Atari XL/XE, and the program automatically detects whether a mouse is present - although it cannot determine the mouse type. The default configuration is for an Atari mouse, and use of a Commodore mouse requires the A-TRACK Configuration to be altered (see Section 9 of this User Guide). Note that neither a PC Serial nor PS/2 mouse is usable with the Atari XL/XE ports.

For those users familiar with normal Atari computer keyboard conventions, note that A-TRACK incorporates its own keyboard handler which deals with some keystrokes in a slightly different way from normal Atari operation in order to provide an easier interface for the selection of command and control functions.

As you have already seen, the **RETURN** key operates in its normal fashion to complete an action, such as loading a file. Generally, the **ESC** key performs the opposite function, allowing you to cancel or abandon an operation. If, for example, the **ESC** key had been pressed at the prompt to load **ATRKDEMO.ITL**, the file load would not take place and you would be presented with a blank List Area and the Title Row continuing to show **'No Item List Loaded'**.

Assuming that the **ATRKDEMO** Item List has been loaded and displayed, you will note that each screen row in the List Area contains an Item which is either a Locomotive, a Consist, or an Accessory. The displayed parameters for each Item are identified on the Title Row as follows -

A Assignment - Source of Commands for this Item

B = Base (Console)

1-8 = Handheld Controller

***** = Item Emergency Stop Activated (at Console)

Item Assignment is only shown when commands for that Item are active

DS% Direction and Speed - Current Value for Loco or Consist

F = Forward

R = Reverse

- = Stopped

Digits indicate Speed as an approximate percentage of maximum speed
Range of values displayed depends on number of Speed Steps being
used by the Item Decoder -

14-Step - 18 to 96% (Step = 6%)

28-Step - 15 to 96% (Step = 3%)

128-Step - 01 to 96% (Step = 0.75%)

L1234 Function States - Current Setting for Item

For Loco or Consist shows states of FL and F1 - F4 only

* = On

For Accessory shows state of Function Pairs F1/2, F3/4, F5/6, and F7/8
in columns headed 1 - 4

< = Fa On, where Fa is F1, F3, F5, or F7

> = Fb On, where Fb is F2, F4, F6, or F8

T Item Type

L = Locomotive

C = Consist

A = Accessory

M = Locomotive Assigned to Consist

Ad Item Address - as programmed into the Item Decoder

Addresses are shown as 3 or 4 decimal digits -

Loco Primary Address 001 - 111

Consist Address 001 - 111

Accessory Address 001 - 511

Loco Extended Address 0001 - 9999

Description Text String describing the Item (22 characters maximum)

Looking at the List Area, you will see that the first 12 characters of the first (top) Item are shown in inverse. This marks the position of the List Cursor. The cursor can be moved, to select an Item for control or for altering its parameters, by using the Left, Right, Up, and Down Arrow keys (←, →, ↑, ↓). Unlike conventional Atari usage, these operate without having to hold down the **CONTROL** key at the same time, since A-TRACK uses the Arrow functions much more frequently than the symbols +, *, -, and =. If you do want to enter any of these symbols into a text string then you can do so by holding down the **CONTROL** key and pressing the symbol key. The other symbols on the Arrow keys (\\, ^, _, |) can be entered as normal with the **SHIFT** key.

Pressing the Right Arrow key will move the List Cursor right, highlighting the other 28 characters of the Item row. The cursor can then be returned to the left Item field with the Left Arrow key. The cursor is moved up or down one row at a time with the Up or Down Arrow keys. Pressing the **TAB** key will move the cursor to the last (bottom) row of the List Area, while pressing **SHIFT-TAB** (ie. pressing **TAB** while **SHIFT** is held down) brings it back to the first (top) List Area row. If the cursor is on the last row of the List Area, the Down Arrow key will cause the Item List to scroll up by one row to reveal the next Item in the List. Alternatively, pressing **TAB** when the cursor is on the last row will scroll the Item List by a complete page (19 Items) so that the bottom Item now appears on the top row of the List

Area. **SHIFT-TAB** has the opposite effect to the **TAB** key. Note that the number of the Item under the cursor is displayed on the Title Row.

The best way to understand the action of the cursor control keys is to use them yourself to move up and down the demonstration Item List. You cannot do any damage to the program or the computer by pressing any of the keys mentioned so far. In general, A-TRACK will not accept any keystroke other than those defined as valid for the section of the program currently being executed. The worst that can happen if you press a valid, but inappropriate, key combination is that the Item List in memory gets corrupted - and it is easy to recover to the last saved version by means of the Menu File functions (see Section 8 for details).

With the List Cursor placed over the left field of any Item, pressing **RETURN** will take you to the Control Screen, with the **ESC** key returning you to the List Screen. Similarly, pressing **RETURN** with the cursor over an Item right field will bring up the Program/Verify Screen, after replying to a set of prompts/queries shown on the Status Row. The functions and operations associated with both Control and Program/Verify Screens are described in Sections 6 and 7 later in the User Guide. Press **ESC** to return to the List Screen.

Instead of using the keyboard, the cursor can be moved with the mouse, assuming that you have it plugged in and operational - if not (and you wish to use the mouse), then plug the mouse into Joystick Port 1 and either reboot the computer or change the A-TRACK Configuration via the Menu functions (see later in Sections 8 and 9 for details) to enable mouse operations.

The List Cursor can be moved to any selected Item field by positioning the Mouse Cursor (an arrow shape) over that field and pressing the left mouse-button (LMB). This operation of positioning the Mouse Cursor over a screen field and pressing the LMB is commonly referred to as 'clicking the mouse', or just 'clicking'.

Clicking on the selected (inverse text) field will then (and in most other cases) perform the same function as the **RETURN** key, taking you to either the Control or Program/Verify Screens. The action of clicking once to select a field, then again to invoke an action, is usually called 'double-clicking'. In the same way as the LMB acts like the **RETURN** key, the right mouse-button (RMB) generally mimics the action of the **ESC** key. Try it and see (but note the comments in the next Section on Emergency Stops).

There are a couple of special usages of the mouse-buttons on the List Screen. You can click (the LMB) on the Status Row to scroll the Item List up by one row to reveal the next Item on the List. Conversely, if you click on the Title Row, the Item List will scroll back down by one row - unless, of course, the first Item is already shown on the top row, in which case the action is ignored. Clicking with the RMB rather than the LMB on either the Status or Title Rows acts like the **TAB** or **SHIFT-TAB** keystrokes, respectively, scrolling the Item List up or down by a complete page (19 rows).

5.2 EMERGENCY STOPS

As you may already have discovered by accident, pressing the **ESC** key (or clicking the RMB) while on the List Screen will generate an Emergency Stop command to whichever Item is highlighted on the screen, provided, of course, that the Item is either a Loco or Consist. As an indication that an Emergency Stop has been activated a 'train horn' alarm sounds and, if the Item is not currently assigned to a command source, an asterisk (*) is displayed in the 'A' column. With an Accessory selected the keystroke is ignored.

The Item Emergency Stop command is sent to the Item as a standard Speed & Direction command, and will remain in effect until cancelled or superceded by another Speed & Direction command sent to that Item. See Section 6, which deals with the Control Screen, for a description of how this is done.

An Emergency Stop All command can be broadcast to all Items from any place in the A-TRACK program by pressing the **BREAK** key. Pressing the **BREAK** key a second time will disable the DIU output and effectively remove power from the track. A-TRACK monitors the status of the DIU and, after the second press of the **BREAK** key, will sound a two-tone alarm if it appears that it has failed to disable the DIU and track power. The user is then expected to switch the track power off by hand, by moving the DIU Power switch to the Off position.

At any point in this sequence a press of the **ESC** key or the RMB will cancel the Emergency Stop All command, remove the status/error message from the Status Row, change the Status Row colour from Red back to Yellow, and give you the option of restoring all speed and/or function commands which were active when the Emergency Stop All was invoked. Restoring these commands needs to be done with due consideration of the consequences (such as allowing a Loco to resume maximum speed immediately) but offers a quicker option to get the layout back in operation after a minor derailment, for example, than re-entering the command sequence for every Item currently being controlled. After completion of an Emergency Stop All command A-TRACK will return you to the List Screen. If the DIU was switched off during the Emergency Stop sequence then it should be switched back on at this point.

5.3 EDITING THE ITEM LIST

As mentioned in the Overview, the loaded Item List can be edited, either to rearrange the order of Items for more convenient access and operation, to simply add new Items or delete those which are no longer required, or to transfer Items to and from other Lists. Note that A-TRACK will not permit editing of the Item List when any Items are under active control.

An Item is deleted from the Item List by moving the List Cursor to the Item's position (either field) then pressing the **DELETE** key (**SHIFT-BACKSPACE**). The selected Item disappears from the display and the following Items move up one row to fill the gap. The deleted Item is not destroyed but is moved to the Delete Buffer (a reserved area of the Atari XL/XE's memory), and you are presented with the option on the Status Row to either Append the Item to the existing contents of the Delete Buffer (if any) or to Overwrite the Buffer contents, ie. place the Item at the start of the Delete Buffer and lose whatever it contained previously.

The Delete Buffer can hold a maximum of 16 Items and, once it is filled, no further 'Delete and Append' operations can be performed. No mechanism is provided to empty the Delete Buffer other than the 'Delete and Overwrite' operation which leaves the last deleted Item in the Buffer on its own.

One or more Items can be inserted into the Item List at the List Cursor position by pressing the **INSERT** key (**SHIFT->**). If the Delete Buffer contains Items previously deleted, you are given the option on the Status Row of inserting (copying) the contents of the Buffer into the Item List. Otherwise, if the Buffer is empty or you decline the copy option, a single Blank Item is inserted at the List Cursor position. The Item which was highlighted by the List Cursor, and the Items which follow it, move down one row to accommodate the new Blank Item. This process can be repeated as often as required until the Item List contains the maximum allowed number (64) of Items. See the later Section 7.7 for details of how to turn a Blank Item into one which is properly defined and ready for use on your layout.

The final Item List editing key is **CLEAR** (**SHIFT-<**) which removes the Item List from memory. Note carefully that **NO** recovery is possible from the Clear operation - the Items are **NOT** moved to the Delete Buffer. If the Item List has been changed in any way since it was loaded, you will be given the option of saving it to disk. Pressing **N** at this point will erase the Item List immediately, whereas pressing **Y** will result in the current Item List's filename appearing on the Status Row. The filename can be edited, as explained in the next section, to allow you to save the altered List to a different disk file, or you may simply press **RETURN** or the LMB to overwrite the existing file. The Item List is then cleared from the computer's memory. Pressing **ESC** or the RMB at any point in the Clear sequence causes the operation to be abandoned and leaves the Item List as it was.

When the Item List is cleared the Delete Buffer and its current contents are left intact. These can now be directly inserted on to the blank List Screen to form a new Item List, or you may load another Item List from disk and insert the saved Items into it. This facility allows you to build up Item Lists containing sets of your defined Items appropriate to whatever operational scenarios you require.

Although not used for editing, there is one other key active when the List Screen is displayed. This is the **INVERSE** () key (located bottom-right on the keyboard and sometimes referred to as the Atari key, since it used to carry the Atari 'fuji' logo on the older 400/800 machines). Pressing the **INVERSE** key activates the A-TRACK Menu at the top of the screen and gives you direct access to a range of program functions including those to save and retrieve Item List files to and from disk. Refer to Section 8 and the Menu description later in this User Guide for detailed operating instructions.

Clicking on the Menu Area performs the same action as the **INVERSE** key and reveals the top Menu level. In either case a press of the **ESC** or **INVERSE** keys, or of the RMB, lets you exit from the Menu back to the List Area.

5.4 EDITING FILENAMES, TEXT STRINGS, AND NUMERICAL VALUES

At various points in the A-TRACK program you will have to enter text in the form of a filename or an Item description, or numeric values to set an Item parameter. All alphanumeric entry is done on the Status Row and several editing keys are available to make the process as easy as possible. The best way to understand the operation of the various keystrokes is to work through an example.

Let us assume that you have the demonstration Item List **ATRKDEMO . ITL** on the screen. Delete some Items by selecting each of them in turn and pressing the **DELETE** (**SHIFT-BACKSPACE**) key. Selecting the Append option when you are prompted will ensure that the deleted Items are all saved in the Delete Buffer. Now insert the Buffer contents back into the

Item List at a different place from where you performed the deletions (just so you will be able to recognise the Item List as different from **ATRKDEMO**) by moving the List Cursor and pressing Insert (**SHIFT->**). Answer **Y** to the '**Insert from Delete Buffer?**' query.

Now press Clear (**SHIFT-<**) and answer **Y** to the prompt '**Item List Changed - Save File?**'. The Status Row should now show '**Save>D1:ATRKDEMO.ITL**' followed by the Text Cursor (a black block character). The Text cursor can be moved with the Left and Right Arrow keys to highlight any character in the filename string, but note that it cannot be moved beyond the start- or end-points of the string. Pressing **SHIFT-TAB** moves the Text Cursor to the start of the string and the **TAB** key moves it back to the end of the string.

Now move the Text Cursor left into the body of the string, to highlight the '**D**' of '**ATRKDEMO**', for example. You will see, from the Text Edit Mode and Text Case indicators at the right-hand end of the Title Row ('**o**' and '**↑**'), that the program is currently set to Overwrite and Upper Case (the normal Atari screen editor defaults). Hence, pressing any letter or number key at this point will replace the '**D**' character with the upper-case version of the selected key. Try it and note that the Text Cursor moves to the right. As you type further characters you will see that they replace the existing characters until you get to the end of the string - at which point you will start adding new characters and the string gets longer. The absolute maximum string length is 34 characters after which any further character input is ignored. Depending on where you are in the A-TRACK program the permissible maximum string length may be set to less than 34 as, for example, when entering or editing decoder address values where only 3, 4, or 5 characters can be accepted.

Entered characters can be removed with the **BACKSPACE** key. Used at the end of the string, **BACKSPACE** deletes the last character and reduces the overall string length. However, if you first move to a position in the body of the string using the Left or Right Arrow keys, a press of **BACKSPACE** still deletes the character to the left of the Text Cursor and moves the Cursor left, but it now leaves a Space (blank) character at the former Cursor position and the string length stays the same. Alternatively, you can use **DELETE (SHIFT-BACKSPACE)** to remove the character under the Text Cursor. Now all the characters to the right of the Cursor position move one place left to fill the gap left by the deleted character, and the string length is reduced by one character. Pressing **DELETE** at the end of the string has no effect on the string or its length.

If you change the Text Edit Mode from Overwrite to Insert, by pressing the **INSERT (SHIFT->)** key (changing the Text Mode indicator to '**i**'), you will find that **BACKSPACE**, used within the body of the string, now operates differently by removing the character to the immediate left of the Text Cursor and moving the rest of the string characters left to fill up the gap, thus decrementing the string length. The operation of the **DELETE** key remains the same as in Overwrite mode. You can see which Mode you are in at any time by looking at the program status indicators on the Title Row.

In Insert Mode pressing an alphanumeric key while positioned within the body of the character string puts the selected character into the string at the Cursor position, moves the rest of the string one place to the right, and increments the string length - unless this would take the length beyond the set maximum value. In this case the character input is ignored. The only way then to insert new characters into the body of the string is to delete some of the existing characters first.

The **CLEAR (SHIFT-<)** key will erase all of the string characters on the Status Row and leave you with a clean slate on which to enter a new character string.

If you wish to input lower case characters you can either press the **CAPS** key to toggle the Text Case (the indicator changes to '↓') or simply use **SHIFT** with the letter key. For filename entry, characters should be in upper case for Atari DOS, although SpartaDOS 3 will accept filenames in either upper or lower case.

For those DOS types, such as SpartaDOS and MyDOS, which allow the use of subdirectories, the maximum string length of 34 characters lets you enter pathnames including at least two levels of subdirectory should you wish to do so.

To return to our current example, once you are happy that you understand the ways the editing keys operate, edit the displayed filename to something like **D1:ATRKEDIT.ITL**. You can, of course, enter any valid filename you like or change the disk drive number, but do not leave it at **D1:ATRKDEMO.ITL** unless you really want to overwrite the demonstration Item List. Remember to preserve the correct format which is -

D(disk drive number)(colon)(File Title)(period)(File Type)

- where the File Title can have up to eight letters or numbers (but must start with a letter), and the File Type consists of up to three letters or numbers. Here **ITL** is used for the File Type to remind you that the file is an Item List, but you can use any letter-number combination that you wish.

Now press **RETURN** (or the LMB) to write the revised Item List to disk - the position of the Text Cursor in the string does not matter - or press **ESC** (or the RMB) to abandon the entire operation.

Any error conditions which might arise because the disk in the drive is full or write-protected - or not there at all - are reported on the Status Row, and can be cleared by pressing the **ESC** key or the RMB. This also results in the Save operation being abandoned.

As the Item List file is being saved you will probably observe that, as when loading an Item List, the colours of the various Screen Areas disappear and all text appears in the same colour as the List Area. This happens because the way in which Atari screen colours are manipulated would otherwise interfere with the handling of the disk drive - for the technically-minded, Display List and Timer interrupts are temporarily disabled. Screen colours are restored as soon as the disk operations are completed (See Section 8.2 for more details on saving and loading Item List files).

After the changed Item List is saved to disk, the Clear operation is completed and the Items disappear from the List Area. You are presented with the option to **Clear State of All Decoders?** which would be appropriate if you were connected to the track - since you can no longer select an Item to control it - but for this example just press either **Y** or **N** to clear the prompt.

Now press **INSERT (SHIFT->)**, answer **Y** to the prompt **Insert from Delete Buffer?**, and note that the Items you previously put into the Delete Buffer appear in the List Area. These Items can form the basis of a new Item List and be saved to disk under their own filename.

Alternatively, after clearing the Item List, you could load a new Item List. This operation is fully described in Section 8 on the Menu but, to continue this example, press the **INVERSE** key, followed by **F** and **L**, which will bring the filename you just edited (to save the previous (changed) Item List), on to the Status Row. You can hit **RETURN** to reload this Item List, or edit the filename to load **ATRKDEMO.ITL** again. Once an Item List is displayed on the screen, the contents of the Delete Buffer can be inserted into the List at any selected point by positioning the List Cursor there and pressing **INSERT (SHIFT->)**. These Delete, Insert, Save, and Load operations can be repeated as often as necessary to generate Item Lists with their content exactly tailored to your specific requirements. Experiment until you are happy you have a clear understanding of the process.

5.5 SCREEN SAVER - ATARI 'ATTRACT' MODE

While working through the User Guide with an A-TRACK display on the screen you may find that, after about 9 minutes without any keyboard or mouse activity (11 minutes on a PAL machine), the computer starts to change the screen colours in a random sequence every 8 to 10 seconds. This is the standard Atari 'attract' mode intended to safeguard your screen from possible damage due to having a static pattern displayed on it, at high brightness, for a long time.

You can exit from 'attract' mode at any time by pressing a key or by moving the Mouse Cursor vertically. You should take care over which key you press because it will be acted upon by the program. The safest key is probably one of the Arrow Keys since they have no immediate, direct effect on any program functions.

6 CONTROL SCREEN

6.1 OPERATION SETUP

Before continuing with this exploration of A-TRACK operation you may find it helpful to restore the displayed Item List to **ATRKDEMO . ITL** - most easily done by rebooting the computer - so that the examples given will match what is on the screen.

With the List Cursor positioned over the left field of any Item, pressing the **RETURN** key, or clicking on the highlighted left field of the Item, will take you to the Control Screen. From here you can issue commands to control the selected Item. Pressing **ESC** or clicking the RMB takes you back to the List Screen with the Item List displayed.

Select Item 003 (Loco LMS 0-6-0T 'Jinty') and go to the Control Screen. The Menu and Status Areas of the screen remain the same as on the List Screen, as does the display of the Item Number and the program status indicators on the Title Row, but the rest of the Title Row now shows headings for the three columns of check boxes, and their descriptive captions, which occupy most of the List Area. Below the check box columns is the Speed Bar which, for a Loco or Consist, gives you an immediate view of the Item's current speed. The speed and direction is also shown as an approximate percentage value prefixed by **F**(orward), **S**(top), or **R**(everse) to the right of the Speed Bar.

Note that, on this initial entry to the Control Screen, two boxes are checked - '**None**' and '**P014**' - showing that commands cannot yet be sent to the Item, but that speed commands, when enabled, will be generated with 14-Step Precision ie. you may set any of 14 defined speeds between slowest and maximum. The Control Cursor is set on '**Stop**' with the Speed Cursor (the 'double-diamond' shape) set at the zero-speed position on the Speed Bar.

The "**P**" symbol in the bottom right-hand corner of the List Area shows that the Item parameters have been edited but not yet sent out to program the Item's Decoder. This has no effect on the operation of A-TRACK but it is there to remind you that the parameters stored in A-TRACK's record of the Item may not match the parameters actually in the Item Decoder at present. Commands sent to the Item might, therefore, be ignored or misinterpreted. Setting of Item parameters and programming of Item Decoders is dealt with fully in Section 7 of this User Guide.

6.2 ITEM ASSIGNMENT & CURSOR CONTROL

The left-hand column, headed '**Assignment**', allows you to set who is going to have control over the selected Item. Setting '**None**' as the assigned command source not only prevents commands being sent to the Item but also cancels any commands which are currently addressed to it. Since there is a limit (64) within A-TRACK on the number of commands which can be active at any one time, assigning '**None**' also effectively makes space for commands to be sent to other Items. In particular, if an Item Emergency Stop command is being sent to an Item, assigning that Item to '**None**' (even if it already has that assignment) will stop further output of the command to the Item.

Selection of an Assignment (or a Speed or Function state, for that matter) is done by moving the Control Cursor to highlight the appropriate check box caption, using the Arrow keys or the mouse in the same way they are used on the List Screen, and then pressing **RETURN** or using a double-click to complete the selection. The adjacent check box is then marked by A-TRACK to confirm your choice.

An alternative way to select a check box caption is to type the first character of the caption, or the first two characters if the initial letter is not unique to a single check box. **RETURN** is then pressed as before to complete the selection.

If, when you set the Item Assignment to '**None**', a Speed & Direction command is active for the Item (not really good operational practice) then the command is changed to an Item Emergency Stop, to reduce the Item's speed to zero, before the command is cancelled and removed from the output command list. As usual, the output of the Item Emergency Stop command will be indicated by the sounding of the 'train horn' alarm.

Assigning an Item to '**Base**' gives you control over that Item from the computer console, via either keyboard or mouse, and allows you to send both speed and function commands to the Item. There is no restriction on how many Items can have a '**Base**' assignment other than the practicalities of you, the console operator, keeping track of several Items at once and switching to the Control Screen of each individual Item as necessary.

The next block of eight check boxes in the left-hand column allows you to assign this Item to one of up to eight Handheld Controllers - providing the use of Handheld Controllers is enabled in the A-TRACK Configuration (see Section 9). Setting up Atari Paddles as the Controller Type would allow the use of **H1** and **H2** as valid Handheld Controller assignments, whereas selecting A-TRACK Handhelds would permit usage of the full range, **H1** to **H8**. The two-letter abbreviations in the Handheld check box captions indicate the colour coding used to identify a specific A-TRACK Handheld Controller -

H1	Red
H2	Yellow
H3	Green
H4	Blue
H5	Violet
H6	Grey
H7	White
H8	Black

Only a single Item can be assigned to a Handheld Controller at any one time.

When you assign an Item to a Handheld, a query will appear on the Status Row asking you to specify whether speed control with this Handheld is to be either Centre-Zero or Directional. Select the default mode of Centre-Zero by pressing **C**, **RETURN**, or the LMB - or press **D** to select Directional mode. The differences between the two modes are explained in Section 6.3 which follows.

Using standard Atari Paddles with A-TRACK will allow you to control only the speed of the assigned Loco or Consist. However, if the wiring from the Paddle Trigger buttons to Joystick Port 2 is altered, by connecting the Paddles through the simple adaptor described in Section 11, pressing either Trigger button will activate an Emergency Stop All command. A switch can also be added to each Paddle to control the Item Function FL - normally used to control locomotive lights - see Section 11 for details.

A-TRACK Handhelds provide you with direct control of up to six Item Functions (FL and F1 to F5) as well as the Items's speed and direction, and are fitted with an Emergency Stop button. Further details can again be found in Section 11.

Regardless of the type of Handheld Controller used, Function states for Items assigned to Controllers can all be set or reset from the computer console by selecting the Control Screen for the particular Item and then selecting the appropriate Function check box. This gives you dual control over the Item Functions from either the Handheld Controller or Base.

At the bottom of the left-hand column is a final check box labelled '**Cnst**'. This allows you to assign a Loco to a Consist - provided it has not already been assigned to '**Base**' or to a Handheld Controller ('**H1**' to '**H8**'). The intricacies of setting up Consists is dealt with later in Section 6.5.

6.3 SPEED CONTROL

The function of the centre column, headed '**Speed**', is (obviously) to allow you to control the speed of a Loco or Consist, which has been assigned to '**Base**', using the keyboard or mouse. It also gives you control over the Item's direction, which is perhaps not quite so obvious. As you can see, on initial entry the Item is stopped, and its speed is zero. In line with DCC Standards the speed of an Item can only be set to one of a number of distinct values or steps and, depending on the capabilities of the Decoder fitted to the Item, you can have 14, 28, or 128 speed steps, with the latter giving the smoothest control.

With A-TRACK you pick a number of steps by which to change the current speed setting Up or Down, ie. to increase it or to decrease it. From stopped, selecting Up steps will make the Item move forward, and you can continue to apply the selected Up value until the Item reaches the desired speed. To slow the Item you would then select a Down step value by which to decrease the speed and eventually bring the Item to a halt. However, continuing to apply the Down value will make the Item go into reverse and to increase its speed backwards. In order to bring the Item progressively to a stop once more, you would then select an Up value again and send it to the Item until the speed reaches zero.

The Loco example on the Control Screen shows that it is configured for 14-Step control. Select '**Base**' to allow us to send commands to the Loco (notionally, at least, since we have not yet connected the DIU to the track) then select '**U1**' (by any of the methods described above) and press **RETURN** (or the LMB if using the mouse). You should see the Speed Bar Cursor move to the right, and the Direction/Speed indicator change to '**F18**', equivalent to the first forward speed-step.

Note, in passing, that the Status Row now shows that TWO commands are active - these are the Set Speed & Direction command packet to this Loco plus an Idle command packet. When you issue a command to an Item, A-TRACK adds it to its set of active command packets and sends this set repetitively to the track. The DCC rules do not allow consecutive command packets to be sent to the same Item, so A-TRACK will add one or more Idle packets to the set to 'space out' the real commands. Once you have more than about six commands active, A-TRACK can generally sort them into an order which keeps command packets for the same Item separated and avoids the need to insert extra Idle packets.

Going back to our Control Screen example, pressing **RETURN** again, or clicking once more on the '**U1**' caption, will increase the Loco's speed by one more step, or approximately 6%, and you can continue up to the maximum speed (displayed as **F96**) at which point further

presses of **RETURN** or the LMB are ignored. Note that the Set Speed & Direction command to the Loco is simply reissued each time with the new speed value so that the command count reported on the Status Row remains at 02.

With the Loco proceeding forward at some speed, it can be brought to an immediate halt by selecting '**Stop**' and pressing **RETURN** (or by double-clicking on the '**Stop**' caption), or its speed can be reduced by activating a Down value. To continue the example, select '**D1**', hit **RETURN** or the LMB several times, and note how the speed reduces by one 6% step on each keypress or mouse click, with the Speed Bar Cursor moving back towards the left. Eventually the speed will reach zero, at which point the next press of **RETURN** or the LMB will start the Loco going backwards and the Direction/Speed indicator will change to '**R18**', showing the first reverse speed-step.

Changing speed one step at a time is reasonable with 14-Step (or even 28-Step) control but it can be a little tedious when 128-Step operation is selected. Try it for yourself by first assigning the Loco back to '**None**', using the keyboard or mouse, then type '**P1**' (or use Arrow keys or the mouse to get to the P128 Step Precision check box) and hit **RETURN** or click the LMB. You can now reassign the Loco to '**Base**', and repeat the Up and Down Speed example given above. Note that A-TRACK will not let you change the Step Precision when the Loco or Consist is assigned to the computer console or to a Handheld Controller - otherwise the command sequence can get a bit scrambled.

With 128-Step Precision set, you will see how long it now takes to get to maximum speed, forward or reverse, although the process can be speeded up (!) by simply holding the **RETURN** key down and letting the computer's auto-repeat function do the work (Note that the mouse does not have auto-repeat on its buttons).

The easier way to get to a set speed with any value of Step Precision is to use the multistep Up and Down check boxes (**U2 - U6, D2 - D6**). These, as you can no doubt work out for yourself, increment or decrement the Item's speed by the appropriate number of speed steps each time you press **RETURN** or the LMB. Note that A-TRACK will not let you go directly from a forward speed to reverse (or vice-versa) in a single operation - you have to go via the Stop position. In practice, due to the inertia of the Locos (real or programmed into the Decoders) this little trap is not likely to have much visible effect on the Locos' movements, but it might stop you, the operator, from doing something you did not quite intend. In our example, if you reset the Step Precision to 14-Step ('**P0**') and experiment a little you can see how this works. From '**Stop**', '**U6**' will take you directly to maximum speed, then '**D4**' will take you back to speed-step 6 (**F48**). A further application of '**D4**' would, in theory, move the Loco into reverse (to **R24**) but it actually brings it to a stop (**S00**), and it takes a further press of **RETURN** or the LMB to get to reverse speed-step 8 (**R60**). From here '**D4**' will produce maximum reverse speed, or '**U5**' will bring the Loco back to a halt.

As an aside, the speed-step precision for any Loco is determined primarily by the capabilities of the fitted Decoder. The setting of Bit 1 in the Decoder Configuration Variable Number 29 determines whether standard Speed & Direction commands should be interpreted as specifying 14-Step Precision (Bit 1 = 0) or 28-Step (Bit 1 = 1), and you can set this up when programming the Decoder (See Section 7 which follows). A different (Advanced) Speed & Direction command type is used to send 128-Step speed commands and these may not be accepted by all Decoders - so check the particular Decoder specification before using the 128-Step option.

If you assign the Loco to a Handheld Controller you can control its speed directly by rotating the control knob, without having to worry about the number of speed steps Up or Down to select. The operation of the speed control knob of all Handhelds can be defined, for each Handheld Controller individually, as either Centre-Zero or as Directional, to suit your personal preference. The selection of operating mode is made, as described in the previous section, when a Handheld is assigned to an Item.

In Directional mode the Loco speed is zero (Stop) with the control knob rotated fully counter-clockwise. Speed is increased by rotating the knob clockwise, with the direction of the Loco (Forward or Reverse) set by the position of the Direction Select switch. This switch is built into the A-TRACK Handhelds, but a suitable toggle switch will have to be added to Atari Paddles in order to use them in directional mode. Details of this (and other useful modifications) are described in Section 11. Note that, if you have not fitted such a switch to your Atari Paddles, then you should not try and use them in Directional mode - unless, of course, you only ever want the assigned Locos to move forwards!

In Centre-Zero mode the Stop position is around the midpoint of the control knob's rotation, from which the knob is rotated clockwise to move the Loco forward and counter-clockwise to move in reverse. There is a 'dead-band' built in to allow you some latitude in selecting the Stop position, and the nominal zero-speed point is marked on the A-TRACK Handhelds. When using Atari Paddles, you should place marks on the Paddle knob and on the body to align at the zero-speed position.

Knowing the zero-speed position of the Handhelds (in either mode) is important after an Emergency Stop is activated (either to an Item via **ESC**, or broadcast to all Items via **BREAK** or a Handheld 'Emergency Stop' or 'Trigger' button) since, as soon as you return to normal operation, the A-TRACK software will resume the generation of speed commands, based on the control knob position, to any Loco assigned to that Handheld. The Loco will, therefore, move off again even if you cancelled the restoration of speed/direction settings following the Emergency Stop! What you SHOULD do in this situation is return all Handheld Controllers to the zero-speed position BEFORE cancelling the Emergency Stop.

Note that, where a Direction Select switch is fitted to the Handheld Controller, the switch is also effective in Centre-Zero mode. Switching to the Reverse position makes the speed control work in the opposite direction, where the knob is rotated counter-clockwise from the Stop position to move the Loco forward, and clockwise to move in reverse. Whether you regard this as a feature (or a quirk to be avoided) is ultimately down to your personal preferences!

A final point to note when Handheld Controllers are in use is that the display of current Loco and Consist speeds (in the **DS%** column) is not continually updated on the List Screen, since this would cause a lot of distracting flicker on the display. The speed values are updated, however, whenever the List Area display is changed for any reason. This occurs after you type anything on the keyboard, so that the easiest way to check on the current speed (and function) settings of Items under Handheld control is to press a key, such as the Spacebar, which has no specific List Screen function assigned to it. If you hold the Spacebar down you will be able to see a continuous display of Loco and Consist speeds as they are changed - as long as you are willing to put up with the screen flicker.

6.4 FUNCTIONS & ACCESSORY CONTROL

Returning to the Control Screen display, the right-hand column (headed '**Function**') allows you to set the states of the Decoder Auxiliary Functions. A-TRACK provides the facilities to control the full set of Functions defined within the DCC command structure, namely FL (the headlight Function) and Functions 1 to 8. Very few Decoders support all nine Auxiliary Functions so, again, you will have to check each particular Decoder specification to determine which Functions can be used and controlled. A command to a Decoder to set the state of a non-implemented Function will just be ignored and will not cause any detrimental effects.

Functions can be either On or Off. The default state is Off and is shown on the Control Screen as an empty check box next to each Function. When handling a Loco or a Consist each Function operates independently of the others, and is switched On by selecting the appropriate caption with either the keyboard, then pressing **RETURN**, or by double-clicking on it. The adjacent check box is then marked by A-TRACK to indicate the state of the Function. Switching a Function to Off is done with exactly the same sequence of actions - just hit **RETURN** or the LMB to toggle the state when the required Function is highlighted.

Functions are controlled through three types of DCC commands. Functions F1 to F4 are controlled with a Function Group One command, and Functions F5 to F8 with a Function Group Two command. Function FL is controlled via the Speed & Direction command if 14-Step Precision is selected but via the Function Group One command when you use 28-Step Precision. Hence, with our example Loco, if you already have a 14-Step Speed command active, activating FL will not generate an additional command - try it and see. On the other hand, activating F2 and F7 will result in two extra commands being generated. Since, in this example, all the commands are being sent to the same Item they will be separated by Idle command packets, so that the total number of commands reported on the Status Row should be six (06).

Accessory Decoders operate in a slightly different fashion. Although Functions may still only be On or Off, they are considered to work in pairs, ie. F1 and F2, F3 and F4, etc., as shown by the link symbols to the right of the **Function** column. These pairs of Functions are generally employed to drive such devices as turnout motors with F1, for example, connected to move the turnout in one direction and F2 to move it back in the other. The allowable states of each Function pair are, therefore, both Off, or either one On, but not both On together. Hence, if you switch F1 On, for example, and then proceed to turn F2 On, A-TRACK will automatically switch F1 to Off to prevent a possible conflict at the Decoder.

The easiest way to demonstrate this Accessory operation is to try another example yourself. Leave the current Loco Control Screen and return to the List Screen by pressing the **ESC** key. If you had the Loco in motion with some Functions turned On then you will now see its assignment, direction and speed, and function state displayed under the List Cursor, and the Status Row continuing to show the number of active commands.

Move the List Cursor down to Item 005, an Accessory described as 'Turnouts HomeYard 1-4', and press **RETURN** when the left field is highlighted, or simply double-click on the Item left field, to get back to the Control Screen. It looks much the same as for the Loco but note that, although the Control Cursor is over the 'Stop' caption, none of the Speed or Step Precision check boxes are marked since they do not apply to an Accessory, and there is no Speed Bar Cursor. Enable control by changing the assignment from '**None**' to '**Base**' - until you do that you will find that none of the Functions can be activated.

Now, select F1 and switch it On by pressing **RETURN** or the LMB, then do the same for F2, and observe how F1 is then switched to Off again. If you now switch F2 Off (by just pressing **RETURN** or the LMB) it changes state quite happily, but this time does not affect F1. You can try the sequence in reverse by switching F2 On first, followed by F1, and seeing F2 being cancelled. The same thing will happen when you activate any of the other three pairs of Functions.

Regardless of the number of active Functions, control of an Accessory is exercised through a single pair of commands, so that the number of active commands will only increase by two (plus any necessary Idle commands), as you should be able to see from the Status Row. If you set several of the Accessory Functions and then return to the List Screen by pressing **ESC**, the left Item Field (under the List Cursor) will show the Accessory assignment and the state of the Function pairs with '<' or '>' symbols showing whether the odd (F1 - F7) or even (F2 - F8) Function in each pair is On.

There are a couple of consequences of the way in which A-TRACK handles Accessories that may affect the way you use the system. Firstly, after an Emergency Stop, and particularly if the track power has been cut off for a time, if you choose to restore prior Function parameters then you need to be aware that the pair of commands which will then be output to any active Accessory will only restore the states of the last pair of Functions that you changed. The states of the other three pairs of Functions will depend on the characteristics of the particular Accessory Decoder - A-TRACK will not output any extra commands to restore their states to that shown on the Control Screen.

Secondly, A-TRACK outputs the current pair of commands continuously to the Accessory - until you change its Assignment to **'None'**. If you have set the Accessory Decoder Configuration Variables to provide momentary (fixed duration) outputs to the Accessory, then you should be aware that the constant repetition of the commands sent to the track will most likely result in the the selected Decoder output remaining on continuously until you select another Function pair or, as already said, you reset the Assignment to **'None'**.

Like a Loco or Consist, returning to the Control Screen and changing the Accessory assignment to **'None'** will stop the transmission of commands to the Item and will clear the Item record of the current Function states, although the state of the Accessory Decoder itself should remain as it was last set until you switch off its power supply. Active control can be re-established at any time by selecting a **'Base'** assignment for the Accessory, but note that the initial on-screen indication of the Function states may not reflect the actual states of the Decoder outputs as they were left.

6.5 CONSISTS

Whereas Locomotives and Accessories are reasonably straightforward to deal with, some aspects of Consists may be a little more difficult to grasp. The main point to appreciate is that a Consist does not actually exist as a physical object in its own right. When we talk about a Consist, we are really dealing with two or more Locomotives each with its own Decoder, and where each Decoder has been programmed with Configuration Variable (CV) parameters to suit the characteristics of the particular Locomotive. Some of these Loco parameters - the Consist Address in CV19 in particular - are the only physical existence that the Consist enjoys at all. If we remove the Consist Address from each of the Loco Decoders then that Consist disappears immediately from the track.

Nevertheless, within A-TRACK, an Item defined as a Consist can be dealt with in exactly the same way as you handle a real Loco Item - issuing commands to it from the Control Screen just as described in the preceding sections.

Before you attempt to assign two or more Locos to form a Consist, you will first have to set up the Consist as an Item in its own right. The method of doing this is described in Section 7 but, to let you see how things work, **ATRKDEMO** contains several example Consists ready for use. Looking at the Item List - press **ESC** to exit from the Control Screen if necessary - these are Items 008, 012, and 020 (Fountains Express, Manchester Pullman, and Old Lancastrian).

As an example, we will assign Items 013 and 014 (Locos GWR 28XX 2-8-0 and GWR Manor Grange) to the Consist Item 012 (Manchester Pullman). So that you can see exactly what is going on, stop the generation of any other command packets by selecting any currently active Items and setting their assignments to '**None**'. The Status Row should then indicate that zero (00) commands are active.

Back on the List Screen, note the addresses of the three Items for our example Consist, **L2306**, **L2613**, and (in particular) **C-033**. Go to the Control Screen for Item 013 (Loco GWR 28XX 2-8-0) and select '**Cnst**' as the Item's assignment - using either the keyboard or the mouse as described previously. A prompt will then be displayed on the Status Row requesting you to specify the desired Consist Address. For the example this is 33 (or 033), which you should enter at the prompt after deleting (or by overwriting) the displayed value of **000**, then press **RETURN**. The entered address should now be displayed next to the '**Cnst**' check box caption.

Press **ESC** to return to the Item List and note that the displayed address of Item 013 is now **M-033** instead of its previous value - showing that this Loco has been assigned to a Consist (Multiple Unit) with address **C-033**. Note also that the Loco's assignment is shown as '*', indicating that command packets are being sent to it - as you can also see from the Status Row which shows '**Status: OK - 02 Commands Active**'. In a real situation, with the DIU connected to the track and sending commands to an actual Loco, once you are sure that the Consist assignment has been accepted (see Section 10.3) output of the 'Activate Consist' command can (and should) be stopped by returning to the Loco's Control Screen and selecting an assignment of '**None**'. The '**Cnst**' check box remains selected, and the Consist address remains displayed next to the caption, but the Status Row should now show that no commands are active.

As far as Speed Control is concerned, the Loco Item 013 will no longer respond to commands addressed to its own address (**L2306**), but you can, however, continue to send it Function commands. Just assign it to '**Base**' and activate the desired Functions - although any attempt to set its speed directly will be ignored. The DCC Recommended Practices also provide for the Decoder to be set up such that Item Functions can be controlled by sending commands to the Consist address - by programming Configuration Variables CV20 and CV21 appropriately - but you will need to check the specification of your decoder(s) to see if this feature is supported.

Adding the second Loco (Item 014, GWR Manor Grange) to the Consist is done by going through exactly the same set of steps as for the first Loco - resulting in a change of its displayed address also to **M-033**.

Control of the Speed and Direction of the two Locos is now performed from the Control Screen of the Consist (Item 012, Manchester Pullman), just as for any single Loco. Control of

Functions on the Control Screen also operates as for a single Loco although the effect of the commands will depend in practice on how the Loco Decoders have been programmed. It will also be necessary, in real track operations, to program the speed characteristics of the two Locos to be as identical as possible. This matching operation is likely to require a fair amount of experimentation with the various Decoder parameter values when installed in specific Locomotives unless, of course, the Locos are of the same type and have an identical build state.

Removing a Loco from a Consist to allow it to be controlled individually again is fairly straightforward. Return to the Control Screen of the Loco (not the Consist), ensure that its assignment is shown as **None**, and select **Cnst**. The **Cnst** check box mark and the Consist address displayed next to the caption should then disappear, and you will see from the Status Row that a 'Deactivate Consist' command has been generated. Again, when operating on a real track, once you are sure that the command has been acted upon (see Section 10.3), it should be removed by selecting a **None** assignment. Returning to the List Screen will show you that the Loco's individual address has been restored, and it can now be controlled as an independent Item.

7 PROGRAM/VERIFY SCREEN

7.1 OPERATION SETUP

As with the description of Control Screen operation in the previous section, before continuing you may find it helpful to ensure that the displayed Item List is **ATRKDEMO . ITL** (reboot the computer if necessary) so that the examples given will match what is on the screen.

With the List Cursor positioned over the right field of any Item, pressing the **RETURN** key, or clicking on the highlighted right field of the Item, will take you to the Program/Verify Screen. From here you can edit the contents of all Decoder Configuration Variables for the selected Item, set the Item Type, and enter or edit the Item Description. The edited values can then either be transferred to the Decoder in the Item (in Program Mode), or compared to the values already programmed into the Decoder (in Verify Mode), through the DIU.

Using Item 003 (Loco LMS 0-6-0T 'Jinty') as the example once more, select the right field and press **RETURN**, or just double-click the right field. A message '**Check DIU Set to Program Mode**' will appear on the Status Row. This is to remind you to set the Mode Select switch on the DIU to the '**PROGRAM**' position before proceeding, so that the DIU can provide the correct acknowledgement of programming commands. Press **Y** to proceed - pressing **N**, **ESC**, or the RMB takes you back to the List Screen.

A further query then appears, asking you to select either Program or Verify Mode. For now, press '**P**' for Program Mode (again, pressing **ESC** or the RMB lets you abandon the whole operation and return to the List Screen) and proceed to the next query which requests you to select the Configuration Variable Access Mode for the type of Decoder fitted to the Item. The options (as defined in the NMRA DCC Recommended Practice RP 9.2.3) are Address-Only Access (**A**), Physical Register Access (**R**), Paged CV Access (**P**), and Direct Access (**D**). Direct Access gives the fastest programming speed but is only supported by the most recent types of Decoder on the market (and then not always fully). A-TRACK, therefore, defaults to Paged Access, since that appears to be the mode supported by the majority of modern Decoders. The Physical Register and Address-Only modes only allow you to have access to a very limited subset of the Configuration Variables and are only provided, really, for compatibility with older Decoders.

Study of your particular Decoder's specification should help you decide in practice which option to select, although the recommendation is to try Paged Access first, and only revert to Register Access if that does not appear to work. Since Address-Only Access only lets you change the Item's Primary Address it is not a lot of use in setting up the operational parameters of your locomotives. For now, just press '**P**' (or **RETURN**) to get you, finally, to the Program/Verify Screen.

If you do not have the DIU connected, or have it powered Off, or you have the DIU connected and powered On, but have left the Mode Select switch at '**OPERATE**', an error will result at this point, with the display of 'Error 206' on the Status Row. Pressing **ESC** to clear the error display will then produce the prompt '**Ignore Further DIU Status/Errors?**'. As explained in Section 4.3, choosing to ignore errors is allowable for demonstration purposes but will lead to loss of control when you are connected to a real track and locomotives. Hence, choose **Y** if the DIU is non-operational, or set the DIU into the correct operating mode, press **N**, and continue. Either option will take you back to the

beginning of the sequence of prompts to set up Program/Verify operations, as described above.

When you get to the Program/Verify Screen you will see that the Menu Area is the only area of the screen which remains the same as on the List Screen. The Item Number is still displayed towards the right end of the Title Row, and note there also that the program status indicators now show 'P' for Program Mode. The rest of the Title Row now shows that the List Area contains entries for each of 96 definable Decoder Configuration Variables in the format 'CV Number-Current Value'. In the List Area, below the Configuration Variable values, are the Item Type and (enclosed between '<' and '>' symbols) the Item Description.

As on the Control Screen, the "P" symbol in the bottom right-hand corner of the List Area shows that the Item parameters have been entered or edited but not yet sent out to program the Item's Decoder.

The Program/Verify Cursor is located over Configuration Variable 01, and the Status Row displays the description relating to that CV which is the Decoder Primary Address. Note carefully that, although the CV Numbers are shown as decimal numbers (01 to 96), their assigned values are displayed in hexadecimal. This is not done to confuse you but rather to allow each value, which can range from 0 to 255 (decimal), to be displayed as two characters on the screen (00 to FF). In this example, the highlighted CV01 has the value \$42, equivalent to 66 decimal. For certain of the CVs, where individual bits of the 8-bit value are used to control Decoder functions, it is also a little easier (at least for those of us who are familiar with hexadecimal-binary conversions) to see which bits are set or not from the hexadecimal representation. However, do not worry - you do not have to understand hexadecimal or binary notation in order to use A-TRACK since, as we will see shortly, you can view and enter all data as normal decimal values.

7.2 EDITING CONFIGURATION VARIABLES

Selection of a particular CV is done either by using the Arrow keys or the mouse as on the List and Control Screens. To illustrate this, press the Down Arrow key several times and note that, as the Program/Verify Cursor moves down, the message on the Status Row is updated to show the description of the currently-highlighted CV. Where a particular CV does not have a function assigned by the NMRA (such as CV14) the description is shown as 'NMRA Undefined'. These CV values are often used by the manufacturers of Decoders to hold parameters relating to unique functions built into a specific Decoder type. You will need to refer to the specifications of your own Decoders to identify the functions of all CVs other than the standard assignments. You should also be aware that in some types of Decoder the usage of CVs from 33 upwards can differ from the NMRA definitions - again, check the Decoder specifications carefully.

When moved by the Arrow keys, the Program/Verify Cursor "wraps around" so that, for example, when you move to the bottom of a column of CV values the next Down Arrow key press will take you back to the top of the column. This feature operates in all directions, and the best way to appreciate how the Cursor moves is to experiment by holding down each Arrow key in turn. In addition, to speed up selection of a particular CV from the keyboard you can move the Cursor directly to its screen location by typing the two digits of the CV Number.

Once a CV has been selected via the keyboard or by clicking on it with the mouse, you can proceed to amend its value by pressing **RETURN** or by clicking on it again. The CV value is

then displayed, as three decimal digits, next to its description on the Status Row and can be edited using the set of editing keystrokes described previously in Section 5.4.

As an example, select CV01, the Primary Address, and press **RETURN** or the LMB to display its current value of 066, followed by the Edit Cursor, on the Status Row. The value can be changed by using **BACKSPACE** to delete the existing digits and then typing in a new value, or you can use Left and Right Arrow keys to move the Edit Cursor over a digit and then type a replacement value. The latter works in the default Text Edit Mode, Overwrite, but if you change to Insert Mode with the **INSERT (SHIFT->)** key, and have three digits displayed, you will find that all alphanumeric input will be ignored. This is because the CV value in this case cannot have more than three digits and you will have to delete one or more before you can add new digits to the string. It is probably easier to leave the Text Edit Mode in Overwrite for numeric entry. Editing of the CV value can be abandoned at any time, and the original value preserved, by pressing the **ESC** key or the RMB.

CV values can be entered to the Status Row in either decimal or hexadecimal digits. Hex values are specified by making the first digit of the string a '\$' character - most easily achieved by using the **SHIFT-TAB** key to move to the start of the string and typing '\$' followed by the two required hexadecimal digits. Hex digits A to F can be entered in either upper or lower case. Note that you do not have to enter a full string of three characters - it is quite acceptable to enter one, two, or three characters to make up the desired value, although entry of a cleared or empty string will be treated like **ESC**, leaving the existing CV value intact.

When you are happy with any edits you wish to make, press **RETURN** (or the LMB) to enter the new value. A-TRACK then checks that the value is valid in either decimal or hexadecimal format since, during the edit on the Status Row, the program will actually accept any letter or symbol key as input. Decimal values greater than 255 will be converted modulo-256, ie. multiples of 256 are subtracted from the entered value until it is less than 256. Any character in the string which is not a valid decimal or hexadecimal digit (including '\$' if it is not the first character) will generate an error message on the Status Row (Error 202 - Invalid Data). This can be cleared by pressing **ESC**, or the RMB, which will return you to the List Area with the selected CV value unchanged.

It is important to appreciate that A-TRACK only checks that the entered values are valid numbers. It does not check that the entry is an allowable, or sensible, value for the selected CV. In the case of CV01, for example, permissible Primary Addresses range from 001 to 111 (\$01 to \$6F) and the results of attempting to program any value outside this range into your Decoder are somewhat unpredictable.

After pressing **RETURN** or the LMB with a valid data entry (even if you did not actually alter any of the digits on the Status Row) you will see that the separator character between the Number and the Value of the selected CV changes from '-' to '*'. This 'mark' serves as a note to A-TRACK that the CV is one whose value should be programmed into the Item Decoder when the programming process is invoked (See Section 7.4 below). If any of the CV values to be transferred to the Decoder are already set correctly when you enter the Program/Verify Screen you can simply 'mark' them, without editing, by highlighting them and pressing the Space Bar. A press of the Space Bar will also 'unmark' any highlighted CV that you have marked (or edited) in error.

Note that, after editing or marking a CV value, the Screen Cursor is moved on to the next CV position. This makes the editing of a sequence of CV values a little easier, and allows you to mark consecutive CV values simply by holding down the Space Bar.

Most of the Loco CVs have, like the Primary Address, single-byte values. An exception is the pair, CV17 and CV18, which contain between them the Loco's 14-bit Extended Address. Selecting either of CV17 or CV18 will give you a 5-digit numeric string to edit on the Status Row. You can enter up to 5 decimal digits or up to 4 hexadecimal digits preceded by the '\$' character, then press **RETURN** or the LMB, and leave it up to A-TRACK to sort the value out between the two CVs. Again, the entered value is checked to confirm that it is a valid number, but not that the value lies within A-TRACK's allowable range of Decoder Extended Addresses, ie. 00001 to 09999 (\$0001 to \$270F). In all cases A-TRACK will set the top two bits of CV17, as required by the defined DCC address format, and will mark both CV17 and CV18.

The most important Configuration Variable is CV29 in which each bit controls a different feature of the Decoder's operation. To help you set things up correctly, when you select CV29 to edit its value, A-TRACK presents you with a series of questions to answer regarding the desired modes and features, and then constructs the necessary value automatically. If you are unsure whether to answer **Y** or **N** to any question then simply press **RETURN** or the LMB to retain the default (or previously edited) setting. Pressing **ESC** or the RMB at any point during the CV29 edit allows you to abandon the complete operation and leave the value of CV29 unchanged. For further details regarding the function of CV29 you should refer in the first instance to your Decoder's documentation and then, for more general guidance, to the NMRA DCC Recommended Practice RP 9.2.2.

This Recommended Practice, RP 9.2.2, also contains default values for several of the Configuration Variables for Locomotive Decoders. These values, listed below, may already be already programmed into a new Decoder and they are a good starting point for setting up the operating parameters for a new Loco Item. Remember that, even if you leave all of the other values alone, you should reprogram the Primary Address (CV01) from the default to some distinct value (like the last two digits of the Loco's number) before you operate the Loco on your layout. This ought to ensure that you do not end up with two Locos with the same address on the same track, each responding to commands you are trying to send to the other!

CV01	Primary Address	003
CV02	V Start	007
CV03	Acceleration Rate	000
CV04	Deceleration Rate	000
CV05	V High	001
CV06	V Mid	001
CV09	Total PWM Period	000
CV25	Cab Speed Step	001
CV31	Configuration Data #2	000
CV32	Configuration Data #3	000
CV66	Forward Trim	128
CV95	Reverse Trim	128

If you delve into RP 9.2.2 you will find that it is possible for Locomotives to have Configuration Variables numbered from 1 to 512. In practice, the only CV numbers greater than 96 that are currently used are CV105 and CV106 which hold the two User Identity

values (you are free to put any numbers in them that you like - to identify the decoder as your own). A-TRACK actually displays CV105 and CV106 as CV15 and CV16 on the Program/Verify Screen since the real CV15 and CV16 are reserved by the NMRA at present, and should not be used by the decoder manufacturer (or yourself) for any purpose. This makes the screen format tidy although it has the down-side that the real CV15 and CV16 cannot be programmed from A-TRACK - this has not raised any practical problems to date.

The example Item chosen (LMS 0-6-0T 'Jinty') has not had its CV values other than the Decoder addresses set up properly, and CV25 and CV26 contain garbage. You may like to tidy them up as a little practical exercise.

7.3 ITEM TYPE & DESCRIPTION

As well as letting you set the Item Configuration Variables, the Program/Verify Screen gives you access to the Item Type definition and allows you to edit the Item Description. Press the **TAB** key once to move the Program/Verify Cursor to the Item Type Field, then again to move to the Description Field. From here another press of **TAB** will take you back to the Configuration Variable Area at the point you left it, or you can press **SHIFT-TAB** to move back to the Type Field, and **SHIFT-TAB** again to return to the Configuration Variable Area. Selecton can also be done as usual (and probably more conveniently in this case) by using the mouse and clicking on the required Field. A click of the RMB (or pressing **ESC**) will return you from either Field to the Configuration Variable Area.

Pressing **RETURN** with the Type Field highlighted, or simply double-clicking on it, displays a prompt on the Status Row offering the option of selecting the Item as a Locomotive, Consist, Accessory, or None by typing the appropriate initial letter. Pressing **ESC** or the RMB takes you back to the Type Field without making any changes. Note that Item Type 'None' is only included for completeness and serves no useful function other than preventing you from sending control commands to the Item.

If a Type is selected, then it is displayed in the Type Field and you are returned to the Configuration Variable Area, but with the Program/Verify Cursor highlighting CV29 rather than the CV at which it was positioned before you selected the Item Type. Depending on the Type allocated, the value of CV29 may have been changed to identify the corresponding Decoder type, and CV29 is marked for programming (or verification). Having possibly changed the Item Type (if, for example, you are editing an existing Item definition to produce a new Item entry) you can then press **RETURN** to amend the other bit-settings within CV29 to match the requirements of the new Item - and then proceed to update any other CVs which are affected.

If you choose to edit the Item Description via the keystrokes **TAB, TAB,** and **RETURN,** or by double-clicking on the Description Field, you will be presented with the Item Description string on the Status Row. All of the text-editing keys are active as for the filename edit described in Section 5.4. Note, however, that the Item Description has a fixed length of 22 characters, including any trailing spaces (as you can see from the position of the Edit Cursor in our example - 4 character positions beyond 'Jinty'), and you cannot insert any new characters into the string without deleting some of the existing characters first - although you can, of course, overwrite them. When you are happy with the edited Item Description press **RETURN** or the LMB to accept it, and take you back to the Configuration Variable Area at the CV position at which you left it.

7.4 PROGRAMMING A DECODER

Having set up the Item Type, its Description, and all values of its Configuration Variables as you require them, press **ESC** or the RMB to indicate that the process is complete. Provided at least one value has been edited or marked, A-TRACK will display a prompt on the Status Row asking whether you wish to proceed to program the marked CVs into the Decoder. Answering with **Y** will generate the necessary commands to transfer each of the marked CV values to the Decoder in turn - whereas pressing **N** will simply bypass the programming stage. Pressing **ESC** or the RMB instead of **Y** or **N** takes you back to where you were on the Program/Verify Screen.

If no CVs were marked but some change was made to the Type or Description Fields, the programming prompt is bypassed and you are immediately prompted to update the Item record with the entered changes. The Item parameters are amended if you press **Y**, or left as they were if you press **N**. This query cannot be ignored by pressing **ESC**, **RETURN**, or either of the mouse buttons. Whichever response you make leads to a final prompt to check that the Mode Select switch has been returned to the '**OPERATE**' position. Answering **N** and leaving the switch at '**PROGRAM**' will take you back to the List Screen in Program Mode, whereas flipping the switch and answering **Y** will again take you to the List Screen, but this time in Control Mode. Note that the Item display reflects any changes you may have made to the selected Item. Your choice of action at the prompts will, of course, depend on what you intend to do next - staying in Program Mode lets you proceed directly to update the CVs of another Item, for example, using the same Access Mode. Making an inappropriate response will generate an error message on the Status Row but will not cause any harm to the program, the Item List, or the computer.

Going back a stage, and assuming that you did change the values of some CVs, had them marked with '*', and answered **Y** to the program prompt, A-TRACK will attempt to program the Decoder. If, at this stage you are still working your way through the examples, and do not have the DIU connected to a programming track or directly to a decoder, then A-TRACK will receive no acknowledgement to its programming commands, and will change the 'mark' to '?' before continuing with the next marked CV - as you should be able to observe on the Program/Verify Screen.

Having tried and failed to program all of the marked CVs, A-TRACK will ask you whether you wish to try again. Without any Decoder connected this would be somewhat pointless but, in a real situation, you would probably want to check that all your electrical connections were secure, then answer **Y** to the prompt. If the program commands are successfully acknowledged this time, then the CV 'mark' will be changed to '+' - otherwise it will remain as '?'.

Once you complete the programming exercise (or decide to abandon it) the Item Update prompt will appear as described previously, so that you can transfer the new CV values into the Item record, and finally return to the List Screen.

Note that, when you return to the Program/Verify Screen of this same Item, none of the CVs will be marked in any way. The 'marks' are not stored in the Item record and you cannot tell which CV was changed during the previous programming exercise. Hence, if you are experimenting to find the best CV values to use with a specific Decoder/Loco combination, you will have to keep your own record of the original and trial values. As with most things, if you are making changes, then it is a good policy to change only one thing at a time and observe the effects before altering anything else.

Also, when connecting up a Decoder for the first time, it is always a good idea to read the CV values programmed into it by the manufacturer **BEFORE** making any changes of your own - then you can at least get back to a known state. Reading the current content of a CV is done by performing a Verify operation on the Decoder.

7.5 VERIFYING DECODER CONFIGURATION VALUES

If you have followed the example based on Item 003 (Loco LMS 0-6-0T 'Jinty') through to this point you should be looking at the List Screen with the right field of Item 003 highlighted. If the program status indicators at the right-hand end of the Title Row show that you are still in Program Mode (**P**) then you should first return to Control Mode by checking that the Mode Select switch is in the '**OPERATE**' position, highlighting the Item left field, and going to the Control Screen. Then press **ESC** (or the RMB) to return to the List Screen in Control Mode (**C**), and highlight the Item right field.

Pressing **RETURN**, or clicking on the highlighted right Item field, will now take you through the Program/Verify prompts. This time select Verify Mode and Paged Access (**V** then '**P**' or **RETURN**) to get to the Program/Verify Screen. The status indicators on the Title Row should now show Verify Mode (**V**) and CV01 should be highlighted by the Cursor. Cursor movement and CV selection both operate in the same way as in Program Mode.

Note that it is also possible to change Mode directly through the Menu system, as will be described in the next part of the User Guide, Section 8, and so reduce the number of keystrokes you have to make.

The primary purpose of Verify Mode is to allow you to check that the CV values held within the A-TRACK record of the Item are the same as the corresponding CV values currently stored in the Item Decoder, without necessarily changing either set of values. In Verify Mode you cannot edit any of the Item record CV values and, if you press **RETURN**, you will note that its effect is only to 'mark' the highlighted CV, changing the separator between Number and Value from '-' to '*'. The Space Bar can also be used for this purpose, as in Program Mode. Note, as before, that pressing **RETURN** or the Space Bar over any highlighted and marked CV removes the 'mark'.

You may also note, in passing, that you cannot edit either the Item Type or Description in Verify Mode - neither clicking on them with the mouse nor pressing the **TAB** key has any effect.

Once you have marked the CVs whose values you wish to check against the Decoder contents, the next sequence of actions is very similar to that described in the previous section on Program Mode. Press **ESC** or the RMB and answer **Y** to the request to verify the marked CVs - pressing **N** will skip the verification process, and **ESC** or the RMB will return you to the Program/Verify Screen.

As with programming, if there is no Decoder connected to the DIU, A-TRACK will not receive any acknowledgement of the verification commands which it outputs.

Acknowledgement is only generated by a Decoder if the value presented with the verification command matches the actual value held within the Decoder - otherwise it makes no response. Hence, at this point, after failing to verify the value of the first marked CV, and changing the separator from '*' to '?', A-TRACK will offer you the option of determining the actual CV value within the Decoder.

If you accept the option by pressing **Y** then A-TRACK will try to match the Decoder CV value by successively sending each of the possible 256 values for the CV in turn to the Decoder and looking for an acknowledgement when the correct value is presented. This can take an appreciable time as you will be able to observe.

If a matching value is found (either initially or after successive trials), A-TRACK changes the separator to '=', and the verified value is shown on the Screen - otherwise the separator is set to '?' and the CV value is left unchanged. A-TRACK then moves on to the next marked CV and the complete process is repeated. You can skip the determination sequence by answering **N** to the prompt and allowing A-TRACK to attempt verification of the next marked CV.

When using Direct or Paged Access you are able to access any of the 96 CVs displayed by A-TRACK. However, in Address-Only and Register modes, only a limited set of CVs are accessible. Only CV01 is valid in Address-Only mode whereas, in Register mode, you can access CV01 through CV04, CV07, CV08, and CV29 for Loco Decoders, or CV01, CV07 through CV09, and CV29 for Accessory Decoders. In these modes, if you attempt to verify (or program) any of the other (inaccessible) CVs, A-TRACK will take no action other than to change the separator from '-' to 'x'.

After verification and/or determination of all marked CVs has been completed, you are first given the option, as described previously, of retrying the complete command sequence (if any marks are set at '?') and then of updating the Item record with the verified values. Obviously, with an actual Decoder connected to the DIU (or in a Loco on the programming track) where you are trying to acquire the data, you would attempt verification again (after checking connections, etc.) but, for our example, you can answer **N** to both prompts when they are presented, and return to the List Screen.

7.6 ACCESSORY CONFIGURATION VARIABLES

Accessory Decoders contain a different, and smaller, set of Configuration Variables from those Decoders intended for fitting to Locomotives, although they are set up in exactly the same way, via the Program/Verify Screen.

Within the NMRA DCC Recommended Practice RP 9.2.2, Accessory Decoder Configuration Variables are actually numbered from 513 to 1024, although only CV513 to CV521, plus CV541, have defined functions. To simplify the display format these are shown by A-TRACK as CV01 to CV09, plus CV29 (add 512 to get the real CV number). Similarly to Locomotive Decoders, any of the first 96 Accessory Decoder CVs (CV513 to CV608) can be programmed or verified, although the response you obtain will depend on the specification of the particular Accessory Decoder being used. Again, A-TRACK displays the two User Identity values CV105 and CV106 (CV617 and CV618) as CV15 and CV16 on the Program/Verify Screen.

As an example, select Item 007 (Turnouts HomeYard 9-12) from the Item List and go to the Program/Verify Screen. If you move the Program/Verify Cursor down the first column of CV Number-Values you will see that only CV01 to CV09 have functions defined by the NMRA DCC RP 9.2.2. The only other active CV is CV29 which has the fixed value of \$80 (128) to signify that this is an Accessory Decoder. Although you can set the values held in all CVs from 01 to 09 (and any others which might be allocated by the manufacturer of your particular Accessory Decoder) you cannot edit CV29 - as you will find if you highlight it and press **RETURN**, or double-click on it.

The 9-bit Decoder address for an Accessory is split between CV01 and CV09, with the 6 least-significant bits being placed in CV01 and the remaining 3 bits in CV09. Selecting either of these CVs for edit on the Status Row will present you with a four-digit value for amendment - **0103** in the case of our chosen example. As before, you can enter from 1 to 4 decimal digits, or a '\$' symbol followed by 1 to 3 hexadecimal digits, as the desired address then press **RETURN** or the LMB. A-TRACK then automatically assigns the address bits between CV01 and CV09, and marks both CVs to show that their values have been edited. Remember, however, that A-TRACK only checks that your edited value is a valid number, and not that the address lies within the allowable range for an Accessory of 0001 to 0511 (\$001 to \$1FF).

For details of the meaning and usage of the other Accessory CVs you should refer in the first instance to your Decoder's documentation and then, for more general guidance, to RP 9.2.2. In the latter document only CV09 is defined to have a default value (000).

Editing of the Item Type and Description, and then exit from the Program/Verify Screen, initiation of the programming or verification sequence, and update of the Item record is handled exactly as for Locomotive Decoders as described in Sections 7.3 to 7.5 above.

7.7 SETTING UP BLANK ITEMS

When a Blank Item is inserted into the Item List, using the **INSERT** key (**SHIFT->**) as described in Section 5.3, you will see that its Type is 'None', it has no valid address (address 00 is reserved for broadcast commands to be sent to, and acted upon, by all Decoders), and its Description is "Undefined". The first thing to do with it, therefore, (and certainly before attempting to send it any commands) is to allocate it a Type and a valid address. Thereafter, you will need to set its CVs to sensible values, program all the data into the real Item's Decoder, and give it a meaningful Description.

It is probably easiest to follow the sequence of actions if you are working with a real example, so, with the Item List displayed, insert a Blank Item into the List at any convenient point (you can always delete it later, either to remove it completely or to move it to a different place in the Item List).

Move the List Cursor to the right field of the Blank Item and press **RETURN** (or just double-click on the right field) to get to the Program/Verify Screen. If you are not already in Program Mode you will have to answer the normal set of prompts to select it (**P**), and to set the CV Access Mode (**A/R/P/D**). Since we are not intending to actually program a decoder at this stage, the Access Mode does not matter - just hit the **RETURN** key.

Set the Item Type first by pressing the **TAB** key followed by **RETURN**, or by a double-click on the Type Field, and select Loco, Consist, or Accessory by pressing '**L**', '**C**', or '**A**' followed by **RETURN** (leaving the Item at 'None' is not a very useful choice). This action will move the Program/Verify Cursor to CV29. Now, for a Loco or Consist, press **RETURN** again, or click on CV29, and answer the queries presented on the Status Row. As mentioned previously in Section 7.2, if you are unsure of the 'correct' answer to any question you can just press **RETURN** or the LMB to assign the default value. A-TRACK will then set the appropriate value into CV29.

Next, set one or more valid address values for the Item, bearing in mind the allowable address ranges quoted previously, and the need to give this new Item an address which is different from other Items in the List. For a Loco you need to enter a Primary Address to CV01 and, if Extended Addressing was enabled in the setting of CV29, an Extended Address

value in CV17 and CV18. A Consist only requires a Primary Address in CV19 (see Section 7.8 below), while an Accessory should have its Address loaded to CV01 and CV09.

Once these steps are completed the Item is 'safe' in that commands can be sent to it without risk of interfering with other Items under control. You can then set up those remaining CV values required to operate the type of Decoder fitted to the Item itself whenever is convenient - and with reference to the manufacturer's documentation. You can also edit the "Undefined" string to give the new Item a proper Description. It is not necessary to program the set CV values into the Decoder straight away - again this can be left to a convenient time - but note, as mentioned previously, that the CV 'marks' are not preserved when you leave the Program/Verify Screen, and you will have to 'mark' the relevant CVs again before they can be transferred to the real Decoder.

Complete the Item initial setup by pressing **ESC** or the RMB, choose to program the Decoder or not as you wish, then answer **Y** to the query **'Update Item with Changes?'**, and check that the new Item parameters shown are as intended. Before you quit A-TRACK you will also need to save the revised Item List to preserve the results of your editing - otherwise all changes to the Item List will be lost. Saving files and quitting the program require the use of the Menu, and such topics are dealt with in Section 8 which follows.

7.8 CONSISTS

The setting up and control of Consists has been covered already in Section 6.5, but there are a few points regarding programming which need to be clarified.

One point of which you should be particularly aware is that DCC commands do not distinguish between Consist Addresses and Loco Primary Addresses. So, if you are not using Extended Addresses for any of your Locos on the track, ensure that their Primary Addresses are all different from any Addresses you wish to allocate to Consists.

Since a Consist has no physical existence, A-TRACK will not let you attempt to program (or verify) its (non-existent) Decoder and, therefore, only prompts you to update the Item record when leaving the Program/Verify Screen.

Although the only CV which it is necessary to program, as far as A-TRACK is concerned, is the Consist Address, CV19, you may find it useful to enter other CV values for your own information - perhaps relating to the characteristics which have been programmed into the Loco which will be assigned to the Consist. These CV values will be ignored by A-TRACK, and will have no effect on the control of the Consist.

8 MENU

8.1 ACCESSING THE MENU STRUCTURE

The Menu provides the means to invoke those A-TRACK functions and operations which are not otherwise accessible directly from the List, Control, and Program/Verify Screens covered up to this point (as well as some that are). You can only call up the Menu from the List screen and, as mentioned previously in Section 5.3, this is done either by pressing the **INVERSE** () key (located bottom-right on the keyboard) or by clicking on the Menu Area with the mouse. In either case a press of the **ESC** or **INVERSE** keys, or of the RMB, lets you exit from the Menu back to the List Area.

When you access the Menu Area the Top Menu, consisting of -

File **Edit** **Cmd** **Quit**

- appears on the first screen row, with '**File**' highlighted by the Menu Cursor. The second screen row displays the next level of the Menu structure - in this case the File Menu, consisting of -

New **Load** **Save** **Dir** **Config**

If you move the Menu Cursor progressively to the right by pressing the Right Arrow key you will see the contents of the second screen row change to display first the Edit Menu, namely -

C'Vars **Delete** **Insert**

- followed by the Command Menu -

Item **B'Cast** **Mode**

When you reach the last entry on the Top Menu, '**Quit**', you will note that this does not have a lower level menu and, therefore, represents an 'action'. The action of '**Quit**', obviously, is to let you exit from A-TRACK (the only way out, in fact - apart from switching the computer off), and is invoked by pressing **RETURN** or by clicking on the highlighted '**Quit**' with the mouse.

When you do this a message appears on the Status Row asking you to confirm that you wish to exit from A-TRACK, preceded, if you have changed the Item List in any way, by a prompt to save the altered List file to disk (as you may have already encountered when using the Clear function in Section 5.3). Note that, every time you issue a command to an Item, A-TRACK updates that Item's record with the changed parameters, and thereby changes the Item List - hence you will see the prompt even if you have not made changes directly to the Item's Type, Description, or CV values, For now, answer **N** to either or both prompts, returning you to the Menu with '**Quit**' highlighted.

Any of the other Top Menu entries can be highlighted again by using the Left Arrow key or by clicking on them. You may also use **TAB** to move to the last (rightmost) Menu entry, or **SHIFT-TAB** to move to the first (leftmost) Menu entry.

Select '**File**' and then move to the File Menu either by pressing **RETURN** or clicking once more on '**File**'. The Menu Area should now show the File Menu on the first screen row,

with **New** highlighted, and a blank second row - indicating that **New** is another 'action'. If you check the other File Menu entries, by moving the Menu Cursor to them, you will find that they are all 'actions' except the last, **Config**, which presents its own lower-level menu -

Load Save Amend Def'lt

Details of this Configuration Menu, which allows you to set up some A-TRACK features to suit your own preferences, are dealt with separately in Section 9.

Press **ESC** to return to the Top Menu with **File** highlighted. If you select the Edit Menu by moving the Menu Cursor right and pressing **RETURN**, or by double-clicking on **Edit**, you will find that all three entries are 'actions'. Press **ESC** again to get back to the Top Menu, this time with **Edit** highlighted (and showing how the **ESC** key - or the RMB - lets you retrace your steps up the Menu structure) and repeat the exercise with the Command Menu. In this case **Item** and **Mode** are 'actions', but **B'Cast** brings up the Broadcast Sub-Menu which you will find, if you press **RETURN**, gives you another five 'actions' -

Clear Reset Idle Stop Emgncy

Back out of the depths of the Menu structure with the **ESC** key or RMB, with the final key press removing the Menu display and returning you to the Item List on the List Screen.

Whenever the Menu is activated by the **INVERSE** key or by clicking on the Menu Area, you can use the initial letter of any entry shown on the first screen row as a short-cut to invoke that action or to display the next lower-level menu. This is certainly quicker than using cursor-control keys followed by **RETURN**, but you may still find it easier to double-click on the desired entry with the mouse. Experiment to establish your own preferences.

Having explored the available Menu structure, we can now look at what happens when you select and execute a particular 'action'.

8.2 FILE MENU

New Clears the current Item List after offering you the opportunity to save the List if it has been changed. If you are given the option to save the Item List then you can abandon the whole operation by pressing **ESC** or the RMB - otherwise the Item List is cleared instantly. Note that you cannot clear the Item List if any commands are currently active, since you would instantly lose control of the active Items.

Load Loads an Item List from disk after allowing you to save the current List if it has been changed. The filename of the most-recently loaded Item List appears on the Status Row and can be edited as required to specify the full filename (drive + directory (if appropriate) + filename) of the Item List you wish to load into A-TRACK. Press **RETURN** or the LMB to load the Item List file, but note carefully that pressing **ESC** or the RMB at this stage will result in any current Item List being cleared from memory without a replacement Item List being loaded - as will also happen if any error occurs. If the Load is successful you are presented with a set of queries to answer. You can choose (or not) to issue a set of initialisation command packets to reset the state of all Item Decoders (see Clear, Broadcast Sub-Menu below) and then to restore

the set of Item speed and/or function commands saved with the Item List (see Save below). This has to be done with careful consideration of the likely consequences, as discussed in Section 5.2 with regard to command restoration after Emergency Stops.

Save Saves the current Item List to disk. The filename of the most-recently loaded Item List appears on the Status Row and can be edited as required to specify the full filename (drive + directory (if relevant) + filename) under which you wish to save the current Item List - using the filename extension .ITL will help distinguish Item List files from other file types. Item Lists are saved with a copy of the current active command packet tables and buffers, thus preserving the complete operational state of the layout. Note also that A-TRACK will reload the saved Item List from disk as soon as the write to disk is complete. Any errors which occur at any point during the operation could result in the Item List being lost. For this reason you are strongly recommended NOT to overwrite the existing Item List - either Save with a new filename or to a different floppy disk. You should also make back-up copies of your Item Lists to guard against accidents, and give you some hope of recovery.

Dir Displays a directory of files on disk. The directory to be displayed is defined by the current path which is set to 'D1:*.*' by default. The path is displayed on the Status Row and can be edited to specify whichever path you require. The edited path then becomes the default path which will be displayed in future. Press **RETURN** or the LMB to display the first 18 lines of the directory listing in the List Area. If there are more than 18 lines in the listing, press **RETURN** or the LMB again to display the next 18 lines. **ESC** or the RMB can be pressed at any time to abandon the directory display and return to the Item List. When the directory listing has been completely displayed, a further press of **RETURN** or the LMB allows you to edit the path again to look at another directory. Press **ESC** or the RMB to end the operation.

Config See Section 9

Whenever a Load or Save operation is performed, it is necessary for A-TRACK to suspend its normal generation and output of DCC commands to the track. All of the Atari XL/XE computer resources have to be dedicated to servicing the transfer of data to or from the disk drive and, as has been noted previously in Section 5.4, you will see the normal screen colours disappear temporarily. Because command output is disrupted, the best course of action is not to have Locomotives on the track during File operations.

This does not mean that you cannot Save an Item List with active Loco commands (in order to preserve the operating state of a layout for display purposes, for example). Once the Locos are running as you require, proceed with the Save operation by entering or editing the filename on the Status Row. A-TRACK will disable command output from the DIU, which effectively cuts power to the track and brings all Locos to a halt, but will not otherwise disrupt the current operation of the software. The Save operation and subsequent reloading of the Item List can then proceed safely, with the DIU being re-enabled once Item List loading is complete. A similar sequence of events takes place when you choose to Load a new Item List,

Even if all Locos are stopped before File operations are undertaken, it is still possible for spurious or corrupt DCC commands (which could cause a Loco to move off unpredictably) to be generated. You can add a further level of protection against such problems during File operations by setting the DIU Mode Switch to the **'PROGRAM'** position. This positively prevents any output from the DIU to the main track. To be absolutely safe you should switch off and restart the Atari XL/XE, DIU, and A-TRACK program after any Save operation.

8.3 EDIT MENU

C'Vars Takes you to the Program/Verify Screen, via the usual set of queries to set the operational modes, to edit the Configuration Variables, Type, and Description of the currently selected Item. Equivalent to highlighting the right field of the Item and pressing **RETURN**, or double-clicking on the Item right field.

Delete Deletes the currently selected Item. Directly equivalent to pressing the **DELETE** key (**SHIFT-BACKSPACE**).

Insert Inserts one or more Items at the current Item List Cursor position. Directly equivalent to pressing the **INSERT** key (**SHIFT->**).

8.4 COMMAND MENU

Item Takes you to the Control Screen from which you may issue commands to whichever Item is currently selected. Equivalent to highlighting the left field of the Item and pressing **RETURN**, or clicking on the Item left field.

Mode Displays a prompt on the Status Row from which you can select the desired Operational Mode directly by typing **'C'**, **'P'**, or **'V'**. If you select either Program or Verify Mode then you will also be asked to select the required Configuration Variable Access Mode (**A/R/P/D**).

Broadcast Sub-Menu

Clear Outputs 24 Decoder Reset command packets followed by 16 Idle command packets in place of any current Item command packets. Equivalent to answering **Y** to the **'Clear State of All Decoders?'** prompt after loading an Item List. This is the standard DCC initialisation sequence before commencing layout control operations. After packet output you are asked whether you wish to restore the prior Item command packets - consider carefully the likely consequences of full command restoration before answering **Y**.

Reset Acts like Clear above but only outputs Reset command packets.

Idle Acts like Clear above but only outputs Idle command packets.

Stop Outputs Broadcast Stop command packets, bring all Items to a halt at a rate determined by their deceleration parameters. As with the other Broadcast 'actions', after packet output you are offered the option of restoring the prior Item command packet sequence.

Emergency Issues an Emergency Stop All command, bringing all Items to an immediate halt. Equivalent to pressing the **BREAK** key (see Section 5.2 for further details).

NOTE: It is not clear whether the current 'actions' offered by the Broadcast Menu are particularly useful, and they may be revised in future A-TRACK Releases.

9 PROGRAM CONFIGURATION

A-TRACK provides the facility, through the Configuration Sub-Menu, for you to adjust some of its characteristics to suit your own preferences. You can select whether to use a mouse (and which type of mouse), define whether to use a particular variety of handheld controller, and select colours for the various screen areas and cursors.

Access the Configuration Sub-Menu via the keystrokes '**INVERSE**', '**F**', and '**C**' or, with the mouse, click on the Menu Area, on '**File**', and then double-click on '**Config**'. This should give you a display on the first screen row of the four Configuration Sub-Menu 'action' entries, namely -

Load **Save** **Amend** **Def'lt**

Leaving '**Amend**' aside for the moment, highlighting any of the other three and pressing **RETURN**, or pressing any of their initial letters, or clicking on the entry with the mouse, will achieve the following -

Load Loads an A-TRACK Configuration File from disk and sets the program configuration according to its contents. The filename of the most-recently loaded Config File appears on the Status Row (probably '**D1:ATRACK.CFG**') and can be edited as required to specify the full filename (drive + directory (if relevant) + filename) of the Config File you wish to load into A-TRACK. Press **RETURN** or the LMB to load the Config File, or press **ESC** or the RMB to abandon the operation.

Save Saves the current Configuration settings to a disk file in the correct Config File format. The filename of the most-recently loaded Config File appears on the Status Row (probably '**D1:ATRACK.CFG**') and can be edited as required to specify the full filename (drive + directory (if relevant) + filename) under which you wish to save the current Configuration. Using the filename extension **.CFG** will help distinguish Configuration Files from other file types, but is not mandatory.

Def'lt Sets the current A-TRACK Configuration to the program's default values, which are -

Atari Mouse Enabled
Normal Mouse Buttons
No Handheld Controllers
Screen Colours as described in Section 4

Note that you can generate and keep as many Configuration Files as you like - perhaps each operator may like to have his or her own - but A-TRACK expects to find, and to load, a Configuration File named **ATRACK.CFG** from drive D1: when you boot the computer, or load and run **ATRACK.COM**. It will ignore any other Configuration File and, if it does not find **ATRACK.CFG**, it will use the program's in-built Default Configuration instead.

Selection of the fourth Configuration Menu entry, '**Amend**', allows you to change the current program settings. A series of prompts appears on the Status Row beginning with the following two -

"**Mouse Selected ?**" **N** = Mouse Disabled
 A = Atari ST Mouse
 C = Commodore Amiga Mouse

"**Swap M'Buttons ?**" **Y** = Mouse Buttons Reversed (LMB = **ESC**)
 N = Mouse Buttons Normal (LMB = **RETURN**)

Reply to the prompts by typing the appropriate letter key, or simply hit **RETURN** or the LMB to retain the current setting. Pressing **ESC** or the RMB at any time will abandon the amendment of the configuration parameters completely, leaving them unaltered.

Note that, if you choose to swap the mouse buttons - to make things easier for yourself if you are left-handed, for example - then you will have to read RMB for LMB, and vice versa throughout this User Guide.

The third prompt allows you to enable the use of Handheld Controllers and to select their type and mode of speed-control operation -

"**Handheld Type ?**" **N** = Handheld Controllers Disabled
 P = Atari Paddles
 H = A-TRACK Handhelds

Note that, if you connect a pair of standard (unmodified) Atari Paddles directly to the Atari XL/XE Joystick Port 2, you should select Centre-Zero Speed Control Mode when you assign them to control a Loco or Consist, as described in Section 6.3. If you select Directional Mode then speed control will only work in the Forward direction - with standard Paddles there is no way to reverse the direction of the Loco or Consist. It is possible to modify the Paddles and add a Direction Select switch, as already provided on the A-TRACK Handheld Controllers, in order to provide proper directional control. Details of this (and other) modifications are described in Section 11.1.

The next set of prompts relates to screen area colour selection. The colours are presented (for ease of programming by the author rather than to make life easy for you, the user!) as a set of hexadecimal values which you can edit to suit yourself. (See Sections 5.4 and 7.2 for more details on editing numeric strings on the Status Row).

Standard Atari colour values are used, as given in the list below, but the colour descriptions given can be a little confusing since the perceived colour (hue) depends very much on the associated intensity (brightness) setting. Colour 0, for example, called 'Black', is actually bright White at the maximum intensity level of E(14), and this change applies to most of the other colours such as the Blues (colours 6 to 9) which tend towards white at high intensity.

Black	0	Medium Blue	8
Rust	1	Dark Blue	9
Red-Orange	2	Blue-Grey	A
Dark Orange	3	Olive Green	B
Red	4	Medium Green	C
Dark Lavender	5	Dark Green	D
Cobalt Blue	6	Orange-Green	E
Ultramarine	7	Orange	F

Each intensity (brightness) setting used to define a screen colour must be an even number ranging from 0 to E (hexadecimal - 0 to 14 decimal), ie. there are eight possible intensities of each hue.

The first two screen colour prompts, for the Mouse and Speed Bar Cursors, respectively, require you to enter two hex digits. The first is the colour (hue) value, followed by the intensity value. The default values appear as -

"**Mouse Curs Clr ? : Value> \$4C**" Red (Mauve), Intensity 12

"**Speed Curs Clr ? : Value> \$FC**" Orange (Yellow), Intensity 12

If you do not wish to change the displayed value then just press **RETURN** or the LMB to preserve it as it is. Otherwise enter your new values, deleting or overwriting the old ones. Any alterations that you make do not appear as screen colour changes until all the colour choice prompts have been answered - which makes it sensible to change just one or two colours or intensities at a time, and observe the result before making further adjustments.

The next series of prompts relate to the Screen Areas and require the entry of three hex digits, representing the intensity of the text characters, the colour value for the area, and the intensity of the background, respectively. These are displayed in the prompt as the three final digits of the current value. The first digit is always zero and should remain so. The default values appear as -

"**Menu Area TxBk ? : Value> \$000C**" Black Text Intensity 00
(White) Backgnd Int'y 12

"**Title Row TxBk ? : Value> \$0E76**" Ultramarine Text Intensity 14
(Blue) Backgnd Int'y 06

"**List Area TxBk ? : Value> \$0AB0**" Olive-Green Text Intensity 10
(Green) Backgnd Int'y 00

"**Status Rw TxBk ? : Value> \$00EC**" Orange-Green Text Intensity 00
(Yellow) Backgnd Int'y 12

"**Error Row TxBk ? : Value> \$0038**" Dark Orange Text Intensity 00
(Red) Backgnd Int'y 08

Make any change you require (or wish to try out), pressing **RETURN** or the LMB to enter them, or to move on to the next prompt without changes. Once all the colour prompts have been presented the screen colours will be updated to reflect any changes you have made, and you will be given the option to accept the new colours, to cancel the complete edit, or to go back to the start and revise your updated values. Press the appropriate option key ('A', 'C', or 'R') or hit **ESC** or the RMB to abandon the configuration process (and ignore any changes which have been entered).

When you are satisfied with your revised A-TRACK Configuration you can call up the Configuration Menu again and save the new settings to a Configuration File on disk. It is recommended that you do **NOT** overwrite any existing **ATRACK.CFG** file without saving a copy. The new file can subsequently be renamed to **ATRACK.CFG** and copied to your Working Disk so that your revised Configuration is loaded every time you start the program

- if you do not wish to load it directly yourself. You can always return to the default settings via the Configuration Menu, or by restoring a copy of the original **ATRACK.CFG** from the Master Disk.

10 TRACK OPERATIONS

10.1 CONNECTIONS

Having persevered to reach this stage, you should have a good idea of A-TRACK's capabilities and the way in which its functions operate. On the other hand, if (like a lot of people) you have skipped directly to this section, then carry on by all means - but be prepared to go back and read up on the essential operating details you will have missed.

The next stage is to connect the DIU to the railroad track and to some decoder-equipped locomotives. For convenience, details of the DIU hardware connections and the method of linking them to the Atari XL/XE and the track, as described in Section 3.2, are repeated here.

The DIU has three pairs of terminals fitted to its rear panel -

Blue	15 Volts AC Transformer Input
Yellow	Output to Programming Track (250mA Max Current)
Green	Output to Main Track (4 Amps Max Current)

- and a pair of monitoring points -

Red	+14 Volts DC Out
Black	Power Ground (0V)

The DIU is supplied with two connecting leads - a 7-pin DIN to 7-pin DIN (straight-through) power lead, and a 50-way ribbon cable (PCB edge connector to IDC header). The latter is designed to be connected to the Atari 800XL Parallel Bus Interface (PBI) port. An alternative 50-way cable, or an adaptor, is necessary to allow connection to the Enhanced Cartridge Interface (ECI) of the Atari 130XE.

The DIU takes power for its logic circuitry from the Atari XL/XE Power Supply Unit. Hence, with your Atari XL/XE computer, its disk drive, and the DIU all switched off, unplug the power-in connector from the rear of the Atari XL/XE (next to the power switch) and plug it into one of the 7-pin DIN power sockets on the left side of the DIU (looking at the DIU front panel) - either socket can be used. Now connect the power lead supplied with the DIU from the other 7-pin socket to the vacated power-in socket at the rear of the Atari XL/XE.

Next, using the 50-way ribbon cable supplied, connect the DIU to the PBI (or ECI) port at the rear of the Atari XL/XE computer. Note that the connector which plugs into the DIU is polarised (a 'bump' at top centre), so that it can only be inserted one way. The ribbon cable should then be kept flat, and not twisted, from the DIU to where it plugs into the computer port. The ribbon cable can be bent or folded to position the DIU at a convenient position above and behind the Atari XL/XE so that its switches are accessible.

A 15 volt AC supply, of up to 4 amps capacity, should now be connected to the Blue terminals on the DIU rear panel. This powers the DIU output circuitry supplying DCC-compatible power and control signals to the track.

IMPORTANT NOTES & WARNINGS :

- (1) The DCC Output power is totally isolated from the 5-volt logic power derived from the Atari XL/XE in order to prevent any damage to the DIU or Atari XL/XE circuitry from inductive voltage spikes generated by locomotives or other items connected to the track. The metal case of the DIU (or PBU) is connected electrically to the ground (GND or 0V) of the Atari XL/XE. The Power Ground (Black) monitoring terminal on the rear panel **MUST NOT**, under any circumstances, be connected to the DIU case, or to any ground (GND or 0V) connections of the Atari XL/XE or any of its peripherals.
- (2) Since, as explained in the Introduction, DCC functions by alternating the polarity of the track output terminals, there **MUST NOT** be **ANY** connections made between the Power Ground or +14V DC monitoring terminals and any of the Main or Programming Track terminals, or to any part of the track itself. Failure to observe this restriction will lead to the destruction of the DIU or PBU power output electronics.

At this point you can check that output power is available by moving the Power Switch to the **ON** position when the Yellow **POWER** LED should light, the Green **ACTIVE** LED should flash briefly then go out, and the Red **OVERLOAD** LED should remain dark. If you have a voltmeter available, you can also observe whether the voltage regulator is functioning correctly by checking that the voltage between the Red and Black monitor points is within the range 14.2 to 14.8 volts.

Return the DIU Power Switch to the **OFF** position then connect the Green DIU output terminals (labelled '**TRACK**') to an appropriate point on your main track layout, and the Yellow DIU output terminals (labelled '**PROGRAM**') to a section of track isolated from the main layout. It is not important which terminal goes to which rail, but note carefully that the lower **TRACK** and **PROGRAM** terminals are linked together within the DIU (labelled '**COMMON**'). If the isolated section of track - to be used for programming your locomotive decoders - is physically connected to the main layout then you should ensure that the common **TRACK** and **PROGRAM** terminals go to the same rail (left or right) so that a locomotive running across the isolation gap does not cause a disruptive short circuit across the DIU outputs.

Once the DIU is connected to the layout, if you have locomotives on the track (with or without DCC decoders), then it is recommended that the DIU Mode Switch is set to the **PROGRAM** position before the DIU Power Switch is turned back to **ON**. This prevents the normal switch-on power surges from causing your locomotives to jerk into motion momentarily. Once the Green **ACTIVE** LED has gone out, you can return the Mode switch to the **OPERATE** position, then load and operate the A-TRACK software as described earlier in Section 4.

10.2 WIRING & OVERLOADS

Since the current which can be drawn from the **TRACK** output is up to 4 Amps, make sure that the gauge of wire you use to connect to the track is sufficient to avoid a substantial voltage drop - the larger the wire diameter the better (within sensible limits, of course!). This is not quite as important with the **PROGRAM** connections since the current here is limited to 250 mA (one quarter Amp).

A layout intended for DCC operation has all of its rail sections energised continuously, instead of only when a locomotive is required to travel through a particular section. This should not cause any trouble with normally-wired layouts, but care needs to be exercised with the connection of turnouts. Here the metal wheels of locomotives and rolling stock can short across the vee rails (beyond the frog) which, unlike the usual situation on a conventional layout, will both be 'live' - and of opposite polarity. A momentary short-circuit will be ignored by the DIU but, if it is prolonged (by a slow-moving train, for example), will probably bring operations to a halt. The easiest solution is to isolate the vee rails from the main track and only energise one of them via the point blades or a switch linked to the tiebar. Further detailed advice on the wiring of DCC layouts is beyond the scope of this User Guide, but most of the information you will need can be found in -

"Digital Command Control - the Comprehensive Guide to DCC"

- Stan Ames, Rutger Friberg, and Ed Loizeaux
- Published by Allt om Hobby
- in co-operation with the National Model Railroad Association
- ISBN 91-85496-49-9

Another book you may find useful for its coverage of electrical and electronic topics, although it does not deal directly with DCC operation, is -

"Model Railroad Electronics - Basic Concepts to Advanced Projects"

- Peter J Thorne
- Published by Kalmbach Books (Model Railway Handbook No. 37)
- ISBN 0-89024-146-5

Because the full track voltage of approximately 15VAC is always present when operating a DCC system, you may find it useful to fit an indicator across the rails to show that your connections are secure and that track power is actually present. The indicator can be either a simple lamp of suitable low-current rating (25 to 40 mA), or a pair of LEDs connected back-to-back with 270 ohm (0.5 watt) series resistors as shown below -

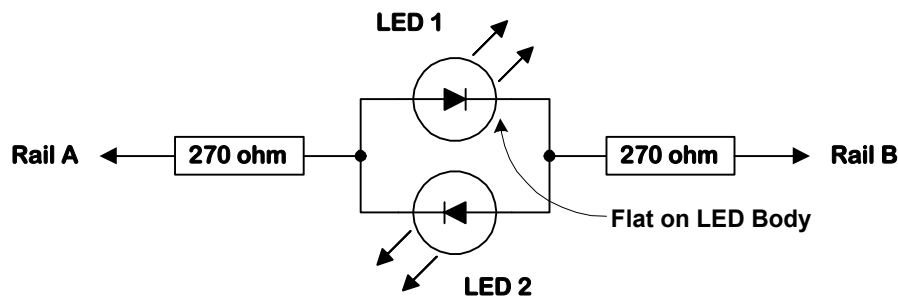

The overload protection provided within the DIU (and PBU) is designed to safeguard the internal electronics against an excessive current being drawn from the unit. It will not necessarily detect a short-circuit across the rails of your layout where the total current taken is less than the trip values (4 Amps on the main track or 250mA on the programming track). This can arise, for example, where the transformer connected to the DIU or PBU cannot supply 4 Amps and maintain its rated voltage, or where thin track connecting wires have been used and are causing too great a voltage drop. It is worth checking your layout carefully for any short- or open-circuit connections (preferably using a multimeter) before

connecting the A-TRACK hardware to the track - it can save a lot of frustration and time later on!

A momentary overload will light the Red **OVERLOAD** LED on the front panel of whichever DIU or PBU is affected. Provided the short-circuit across the track is removed in less than 2 seconds, the DIU or PBU should recover on its own, the **OVERLOAD** LED will go out, and normal operation will be resumed.

However, if the overload condition persists for longer than 2 seconds, the affected DIU or PBU alerts the Atari XL/XE and an '**Overload Detected**' error message will appear on the Status Row of the screen, accompanied by a continuous two-tone audible alarm to ensure that it gets your attention. Your first action should be to switch off the DIU and/or track power, then press the **ESC** key (or RMB) to cancel the error message. Once the source of the short-circuit has been removed you should then be able to switch the DIU back on, and resume track operations - bearing in mind that A-TRACK will still be sending out the same set of commands that it was when the fault first occurred.

Note that an overload condition, like recovery from an Emergency Stop All command, can only be resolved at the Atari console or the DIU, and not remotely through any handheld controllers. Switching off the DIU will disable output to the track from any and all connected PBUs without having to switch each PBU off individually.

10.3 PROGRAMMING DECODERS & CONSISTS

As covered in earlier Sections, the parameter values required to operate a Locomotive in the desired manner are loaded, or programmed, into a Decoder by sending it a sequence of DCC commands. However, programming commands are not addressed to a specific Decoder, but will be accepted by any Decoder which receives them. Hence the connection and use of a separate, isolated section of track on which to place the single, decoder-equipped locomotive that you wish to program. If programming commands were sent on to the main track then every Locomotive there would receive and act on them - not a situation that would be very useful. In particular, if you managed to program all Loco addresses to the same value, it would become impossible to control any Loco individually, which would defeat one of the primary purposes of DCC.

The first step in programming a new Decoder should be to read and record the original parameter values programmed into it by the manufacturer. As explained previously, this is done by performing a Verify operation from the Program/Verify Screen. If the new Decoder is already fitted within a locomotive then you will do this by placing the locomotive on the programming track and following the sequences described in Section 7.5. If, however, the new Decoder has not yet been fitted, then the best way of proceeding is to check its operation directly with the DIU before it is connected into the locomotive.

Looking at your new Decoder you should see that four of the wires emerging from it are coloured Red, Black, Orange, and Grey. These are the track and motor connections. Any other wires are for connection to auxiliary functions and should be ignored for the moment - but ensure that they are kept completely isolated from contact with each other and do not short to the track and motor wires. If you do not feel confident making connections to electronic equipment then seek assistance from someone who is competent rather than risk damaging your equipment.

The normal connections for the Decoder are -

Red	Right Rail) Looking in the forward
Black	Left Rail) direction of travel
Orange	Motor Terminal normally connected to Right Rail	
Grey	Motor Terminal normally connected to Left Rail	

For test and checking purposes connect the Black wire directly to the lower Yellow (**PROGRAM COMMON**) terminal on the DIU rear panel, and the Red wire to the upper Yellow (**PROGRAM**) terminal **THROUGH** a 100 ohm 2 watt resistor - **THIS IS IMPORTANT** to protect the Decoder from inadvertent short-circuits. Connect a load capable of drawing between 50 and 100 mA between the Orange and Grey wires - the Decoder normally produces a maximum output of about 12 volts DC across them, but this will be reduced in our test rig by the presence of the 100 ohm protection resistor. The load can be either an incandescent lamp of appropriate rating, or two LEDs, each with a 270 ohm 0.5 watt series resistor, connected as shown in the diagram below, or even an old locomotive motor. Using a lamp or LEDs will allow you to see the response of the Decoder to Verify and Program commands.

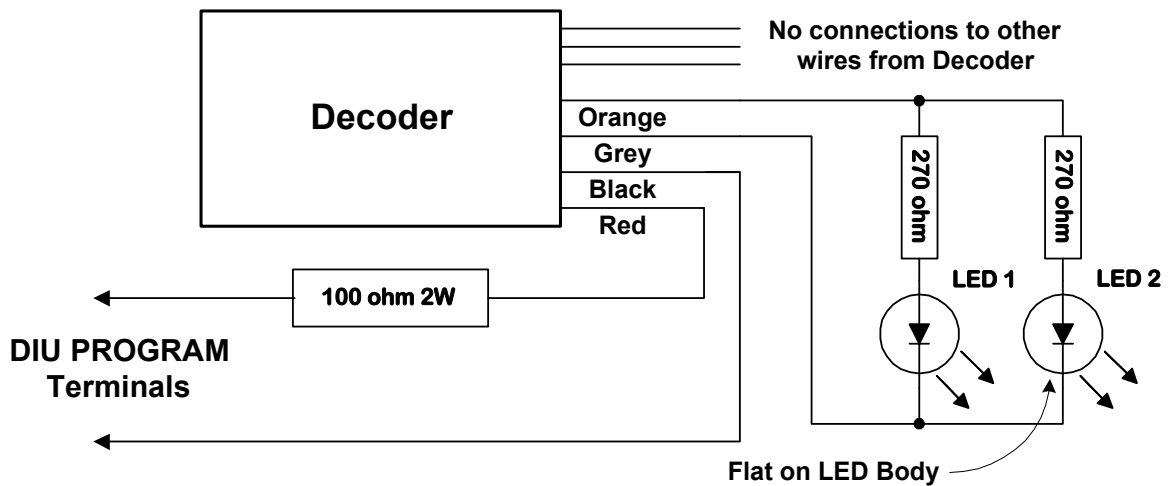

In accordance with the NMRA DCC Recommended Practice RP 9.2.3, Decoders are designed to acknowledge receipt of programming commands so that you can verify that they have been received correctly. In the case of a Loco Decoder, acknowledgement is made by turning on the Loco motor for a brief period and allowing the DIU to detect the momentary increase in current consumption from the track. In our test setup the lamp or LEDs should flash briefly.

Set up a Blank Item with a Type of 'Loco' and a suitable Description for the new Decoder (see Section 7.7), then follow the Verify procedure described in Section 7.5, marking all 96 CV values and letting A-TRACK determine the actual values in the new Decoder. This can take a fair amount of time - just be patient! If there are any problems, and there is no indication from the lamp or LEDs, then check that all your connections are sound and that you have followed all the A-TRACK and DIU setup instructions correctly - then try again! Once the process is complete you can update the new Item record with the extracted CV values and save it with the rest of the Item List on to disk for future reference if necessary.

The next stage of the recommended procedure is to generate a fresh Blank Record for a Loco, with a Description to suit the locomotive in which you are going to install the Decoder, then

continue the Program procedure by setting at least the Primary Address (CV01) to the required value. You can set up any other CV values as well, if you want to alter the default values, using the documentation supplied with the Decoder for guidance, then start the Program sequence. As each CV value is transferred to the Decoder you should see the test-setup lamp or LEDs flash briefly. Again, if this does not occur, check your setup carefully before you yell for help. You can, if you wish, Verify that the Decoder contains your new programmed values - otherwise fit it into a locomotive and proceed to track operations.

If the Decoder is already fitted in a locomotive then you can go through exactly the same process of verification and programming, but this time on the programming track which should be connected to the DIU Yellow **PROGRAM** terminals as described. If you listen carefully to the locomotive when you initiate Verify or Program operations you should hear a short click or buzz from the motor as each command is acknowledged, and the locomotive may jerk forward slightly on the track. If the Decoder is connected to the locomotive headlight or other lights then these may flash briefly as part of the acknowledgement. Additionally, if the locomotive motor draws a high current at start up, you may also observe that the Red **OVERLOAD** LED on the DIU front panel flashes briefly as commands are acknowledged - this will be ignored by A-TRACK unless the overload condition persists for more than 2 seconds.

When you have a Loco on the main track, and assign it to a Consist, you will find that it also generates an acknowledgement of the assignment command. You should be able to hear its motor clicking or buzzing intermittently. When you are sure that this has occurred you should remove the 'Assign to Consist' command by selecting the Loco assignment as '**None**', as described in Section 6.5, before proceeding to operation of the Loco as part of a Consist. A similar sequence of operations will be required when you remove the Loco from the Consist and return it to individual control.

11 HARDWARE OPTIONS & EXTENSIONS

11.1 PADDLE CONTROLLERS

Although you can use standard Atari Paddles as A-TRACK Handheld Controllers they provide a somewhat limited degree of control. Their operation can be 'improved' by a few relatively simple modifications which provide the following -

- Smoother speed control (extended over a larger arc of rotation)
- Emergency Stop All command via the Trigger (Fire Button) on each Paddle
- Direction Select switch
- Headlight On/Off switch

The four modifications are independent of each other, so that you can choose which to add or leave out, but note that the Emergency Stop facility requires you to alter the connections between the common Paddle 9-pin connector and the Atari Joystick Port 2 (which can be done through a simple in-line adaptor), and the addition of either (or both) switches requires you to replace the cables between the Paddles and the Joystick Port (extra wires are needed to connect the switches).

With a standard Atari Paddle you will find that you go from stopped to maximum speed over about two-thirds of the total rotation of the Paddle knob. A larger arc of control can be obtained if the effective electrical resistance of the Paddle control (a 1 Megohm variable resistor) is reduced by soldering a pair of fixed resistors across the variable resistor terminals as shown in the diagram overleaf. The fixed resistor values are 8.2 Megohm and 1.5 Megohm. Note that this modification makes the action of the control slightly non-linear, so that the midpoint of the control range is not at the midpoint of the arc of movement. However, as long as you identify and mark the control midpoint (the Stop position in Centre-Zero operation), this should not give you any significant problems in actual operation.

Normally the Paddle Triggers are connected to Pins 3 and 4, respectively, for Paddles 1 and 2. The Trigger connections should be removed from Pins 3 and 4, and both Triggers should be connected to Pin 6. This can be done by wiring up a simple 9-pin D-Plug to D-Socket adaptor as follows -

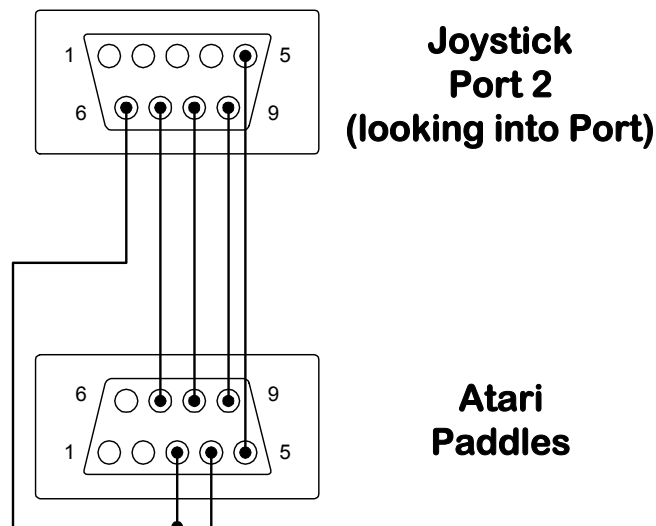

Addition of Direction Select and Headlight switches requires you to add two wires from each Paddle, connecting the switches to pins 1 through 4 of Joystick Port 2. In practice this requires replacement of the Paddle cables and connector (since the standard Atari connector does not have all pins fitted). The complete circuit diagrams of the original and fully-modified Paddles are given below.

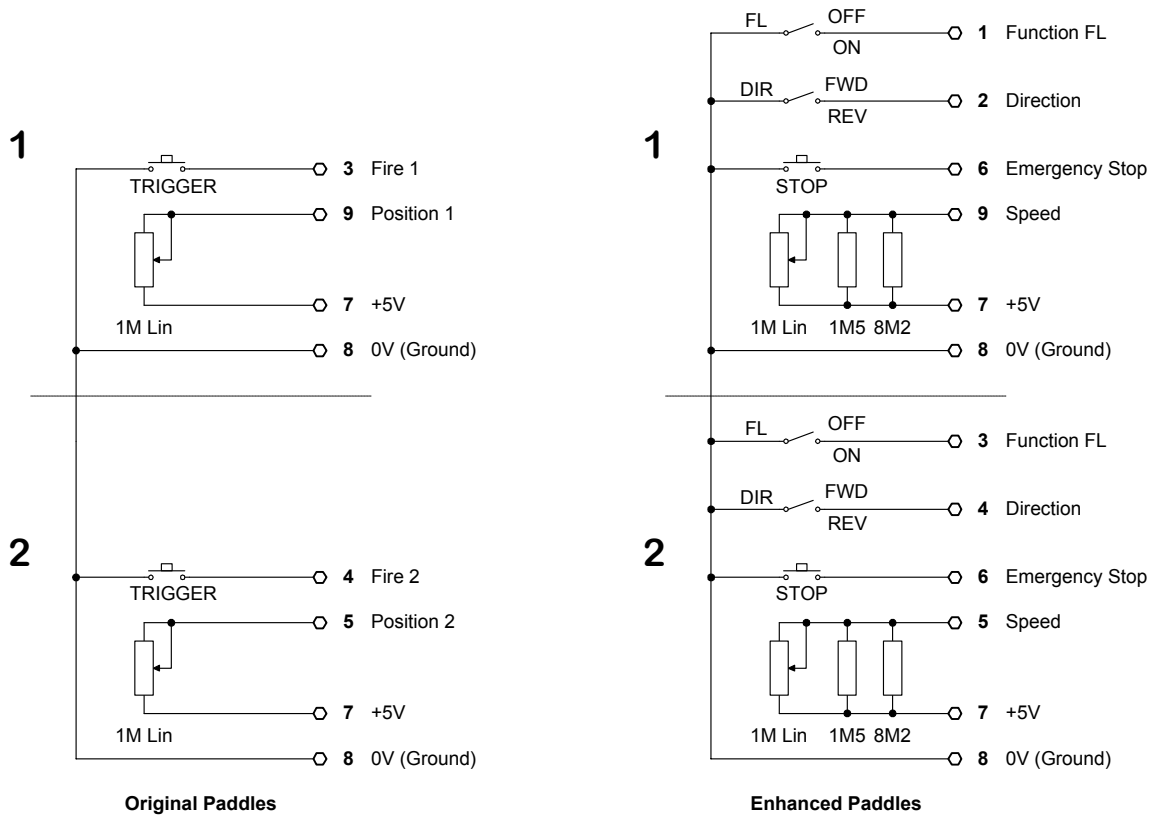

Rather than carry out such extensive modifications to standard Atari Paddles, you may like to consider building your own version of the controllers in a suitable small handheld box. Constructional details are somewhat outside the scope of this User Guide but a suggested layout is also shown below.

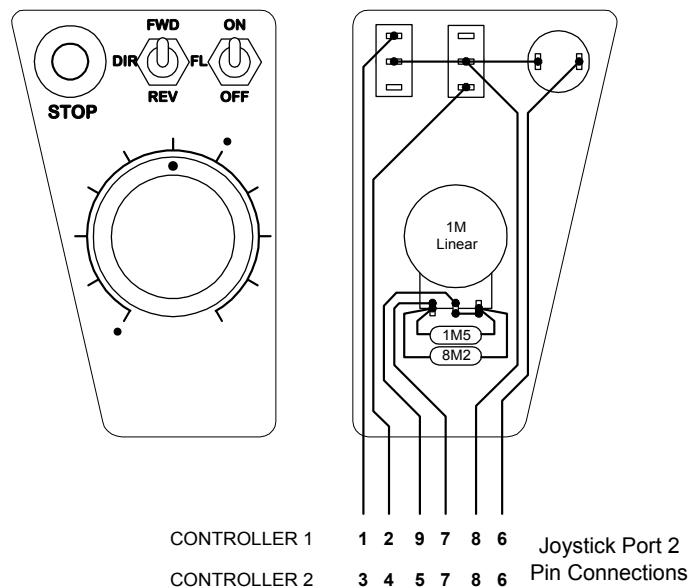

11.2 A-TRACK HANDHELDS

A-TRACK supports the use of its own variety of handheld controller (HHC) which allows you to control all Decoder functions (up to a maximum of six) for the selected Loco as well as Speed and Direction. As many as eight HHCs can be connected to A-TRACK at the same time through a wired network of 8-pin RJ45 sockets. The network is connected to Joystick Port 2 via a Network Driver unit.

Power for the Network Driver is supplied from the '**DCC OUT**' socket on the left-hand side of the DIU (looking at its front panel). Cables to connect the Network Driver to the DIU and to Joystick Port 2 are supplied with the unit. Both cables are simple straight-through connections, using 5-pin DIN (Type B) and 9-pin D-Type connectors, respectively.

The RJ45 sockets of the A-TRACK HHC network are placed around your layout wherever an operator would take up position to operate a train or a yard shunter (switcher), for example. The RJ45 sockets are all linked together, pin-for-pin, using 8-core cable, and then, into the Network Driver as shown in the diagram below. A length of cable terminated with an RJ45 plug is supplied with the Network Driver to let you connect it to your network.

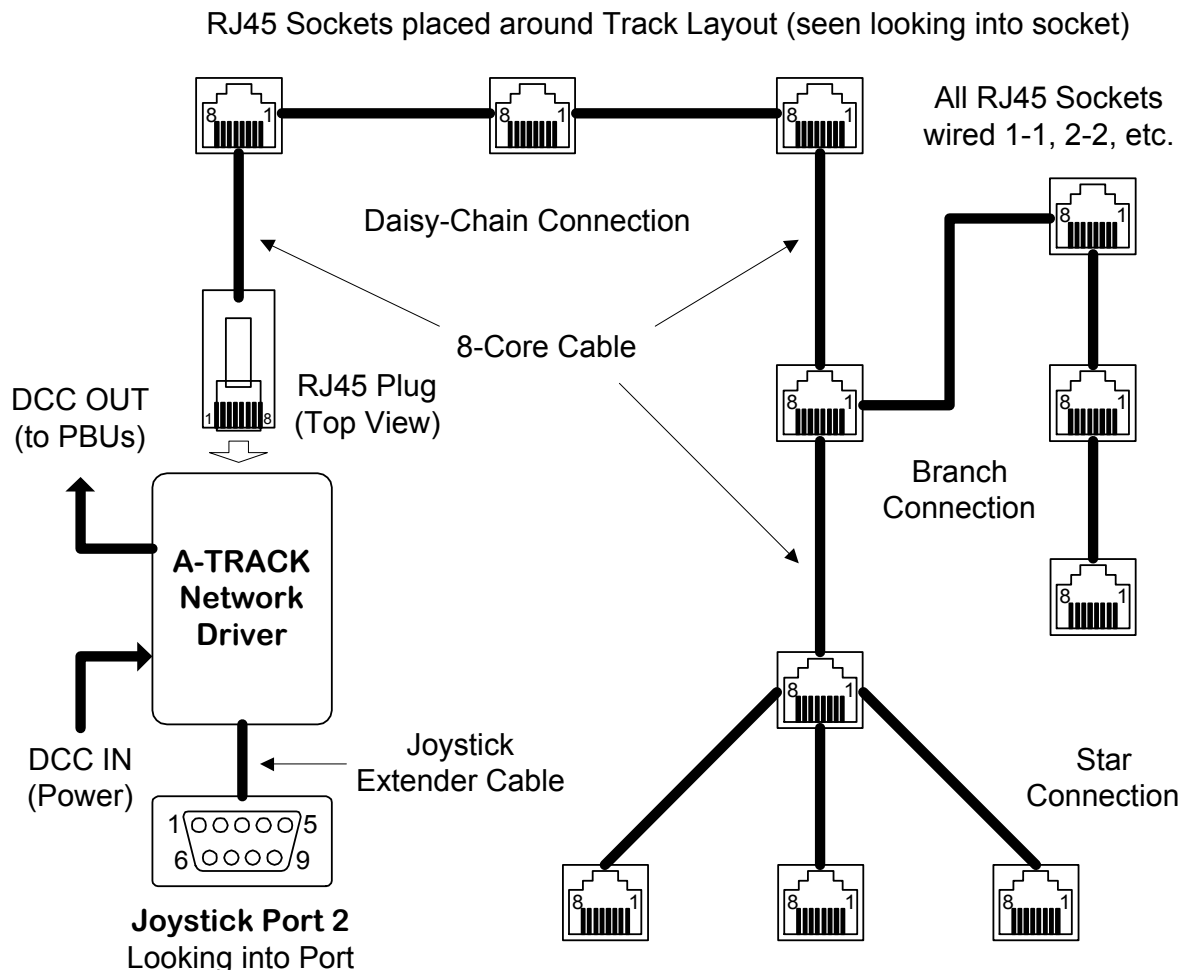

Example of A-TRACK Handheld Controller Network Connections

The wired network can have any structure that suits your layout - a linear daisy-chain, a main trunk with branches, or a star connection - but you should avoid having any loops, and

no RJ45 socket should be further than about 15 metres (50 feet) from the Atari XL/XE. Low-cost 8-core cable can be used (as supplied for domestic alarm or telephone systems) - there is no need to employ the more expensive Category 5 cable designed for high-speed computer networks.

Each A-TRACK HHC is fitted with a 2 metre (6 feet) cable terminating in a standard RJ45 jack which can be plugged into one of the network sockets. Each locomotive that you want to operate in the particular layout scenario is assigned to a specific HHC from the Control Screen, as described in Section 6.2, and the individual HHC Speed Control Mode is set to either Directional or Centre-Zero (select **D** or **C**). Each of the eight HHCs which can be connected to an A-TRACK system has a unique identity which is shown by the coloured sleeve attached to its RJ45 connector, and by a similarly coloured stud on the HHC body, placed just below the '**STOP**' pushbutton (see the diagram below). The identifying colours are also indicated on the Control Screen next to the **H1** - **H8** check boxes -

H1	Red	<i>Identity Code</i>	0000	H5	Violet	<i>Identity Code</i>	0101
H2	Yellow		0001	H6	Grey		1000
H3	Green		0010	H7	White		1001
H4	Blue		0100	H8	Black		1010

The HHC Identity Code is set by a set of link jumpers on the printed-circuit board internal to each HHC, and can be changed where necessary, for example, to replace a faulty unit. **HOWEVER**, you should only attempt this if you are familiar with handling electronic equipment, **AND** take the correct precautions to protect the circuitry of the HHC against damage by static electricity discharges. **ONLY** open the HHC case when you are properly grounded, preferably, by wearing a wriststrap. Where the identity code is altered the colour of the connector sleeve and the plastic stud should, of course, be changed to match.

Each active operator plugs his (or her) HHC into the most convenient network socket and has then full control over the assigned locomotive. Speed is controlled through the rotary knob, and functions by the switches (FL, F2, and F4) and pushbuttons (F1, F3, and F5), as shown in the outline diagram alongside. There is also a Direction switch on the right-hand side of the HHC, primarily for use when Directional mode (**D**) is selected - it reverses the rotary control when in Centre-Zero mode. The large, red '**STOP**' pushbutton, when pressed, initiates an Emergency Stop All command which will bring all Locos to an immediate halt.

As each train progresses around the layout the operator can unplug the HHC and move it to any other network socket as convenient. The assigned locomotive will continue at the speed and function settings active when its HHC was disconnected until the HHC is plugged in again to resume full operator control. Plugging and unplugging of each HHC should be done smartly to avoid spurious electrical transients on the cables. These can cause an unintended Emergency Stop to occur, which, as in all such cases (intended or otherwise), has to be cancelled at the Atari XL/XE keyboard.

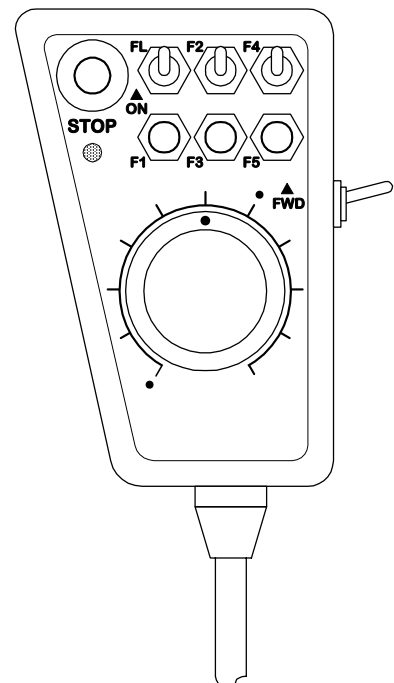

11.3 POWER BOOSTER UNITS

Where the 4 Amp capability of the DIU is inadequate to supply all of the locomotives and accessories that you want to operate simultaneously on the track, the layout can be divided into several electrically-isolated sections, often referred to as 'power districts'. One section (or district) is driven from the DIU, and each of the others will be driven by a slave Power Booster Unit (PBU). Each PBU has its own 15 VAC 4A transformer and receives the stream of bits forming the DCC command packets from the DIU, converting them into the required voltage transitions. Because the DIU and all PBUs are synchronised, locomotives can travel between layout sections without any restrictions, and without any interruption of control.

PBUs are connected using a 5-way cable fitted at each end with the appropriate 5-pin DIN (Type B) plugs (straight-through connection, Pin 1 to Pin 1, etc.), between the '**DCC OUT**' socket on the left-hand side of the DIU (looking at its front panel) and the '**DCC IN**' socket on the right-hand side of the PBU. A further PBU can be added by fitting another 5-way cable connection between its '**DCC IN**' socket and the '**DCC OUT**' socket of the first PBU. The cable lengths between units should not exceed 10 metres (33 feet) each. The number of PBUs which can be added is ultimately limited by the voltage drop in the 5V DC logic supply from the DIU through all of the extension cables. Where a Network Driver unit is connected to the '**DCC OUT**' socket of the DIU (see Section 11.2), the first PBU connects to the '**DCC OUT**' socket of the Network Driver instead of directly to the DIU.

The only other connections required by each PBU are from its Blue terminals to a 15 VAC transformer, and from the Green terminals to the specific section of the track layout it is intended to supply. Supply of 5V DC to the PBU logic circuitry is done through the DIU to PBU cable, so no direct connection needs to be made to the Atari XL/XE power supply. Note that output to the track from a connected PBU is disabled when the DIU is switched to Program Mode. This prevents Program commands from being sent inadvertently to the main track.

Where a number of PBUs are chained together from a single DIU, any of the PBUs can be switched off without affecting the operation of the others as long as the extension cables remain connected. Any fault detected in a connected (and powered-on) PBU, such as an overload or loss of the DCC command stream, will be signalled to the DIU, and acted on as appropriate by the A-TRACK software.

A DIU can be converted into a PBU by changing the position of two internal jumpers. **HOWEVER**, you should only attempt this if you are familiar with handling electronic equipment, **AND** take the correct precautions to protect the circuitry of the DIU against damage by static electricity discharges. **ONLY** open the DIU case when both it and yourself are properly grounded. Preferably, you should wear a wriststrap connected to ground.

The jumpers are located next to the '**DCC IN**' 5-pin DIN socket on the right side of the DIU PCB (looking from the front of the unit), and are labelled LK1 and LK2. Move both jumpers from position 1-2 to position 2-3 to turn the DIU into a PBU. Connections to the newly-created PBU are made as described above.

Note that, once the DIU is converted to a PBU, no connections should be made to the Parallel Bus connector, to the **PROGRAM** terminals on the rear panel, or to the **XL/XE POWER** sockets on the left-hand side of the unit. The Mode Switch of the converted DIU should be set to the **OPERATE** position.

12 ATARI COMPUTER BASICS

12.1 DISK DRIVES AND OPERATIONS

This section of the User Guide is intended to get you started if you are unfamiliar with the Atari XL/XE computer systems, although you should also read the documentation which came with your system. Before applying power, or connecting up any of the A-TRACK components, you should ensure that the basic Atari system is connected together correctly and operating properly.

The minimum set of items you require is -

- Atari 800XL Computer (or 130XE with Parallel Bus adapter)
- Atari 1050 Disk Drive (it is possible to use the older 810 drive as well)
- Atari AC Power Adapters for the Computer and Disk Drive
- Atari Serial I/O Cable to connect Computer to Disk Drive
- TV or Monitor with appropriate cable to connect to the Computer

Follow these steps to connect up the system -

- 1 Make sure the Power ON/OFF switches of your Atari XL/XE Computer (located on the rear panel towards the left side - seen looking at the keyboard) and of the 1050 Disk Drive (located on the front panel) are in the OFF position.
- 2 Plug one end of the Serial I/O Cable into the jack marked PERIPHERAL on the rear panel of the computer console. Then plug the other end of the cable into one of the two jacks marked I/O CONNECTOR located on the back of the disk drive as shown in the diagram below.

WARNING: Your Atari 1050 Disk Drive should be placed 12 inches or more from your television or monitor. Your TV creates a strong magnetic field that could affect the information recorded on your disks.

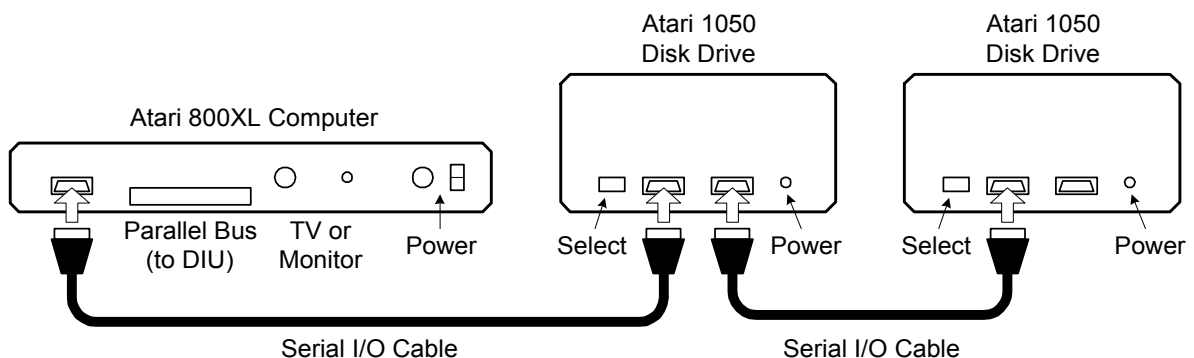

- 3 You can attach up to four Atari Disk Drives, in addition to Atari Printers, Program Recorders or other components, to your Atari Computer. Multiple disk drives (and other components) are connected to each other in a daisy chain, using the Serial I/O Cables supplied with each component. Connection to a second disk drive is shown above, using the two I/O CONNECTOR jacks on the back of each disk drive and another Serial I/O Cable from the remaining I/O CONNECTOR on the first drive to either I/O CONNECTOR on the second drive. Connect any additional components in the same way.

4 If your system includes more than one disk drive, you must set the drive codes using two small switches on the back of each drive. These switches tell the computer which drive you're referring to in your programs and commands. To set the switches turn the drives around so that you can see the DRIVE SELECT window on the back of each drive. Inside the window is a black switch and, behind it, a white switch. Using a pen or a small screwdriver, set the switches in the window to match the patterns shown here for Drive 1, Drive 2, and so forth. You must always have one drive set as Drive 1.

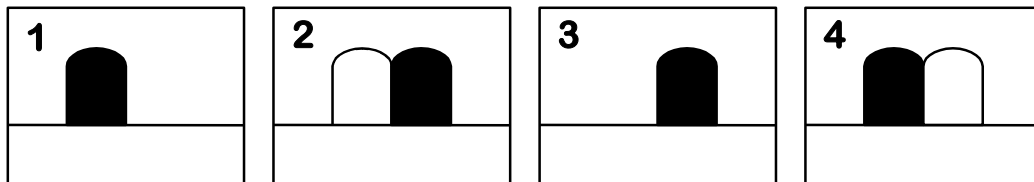

Once you have set the drive switches, be sure to label each disk drive with its number so that you will not mistake one drive for another when using DOS.

5 Plug the smaller end of the Disk Drive AC Power Adapter cord into the hole marked POWER IN on the back of the disk drive (each drive will require its own AC Adapter). Similarly, plug the 7-pin DIN connector of the Computer AC Power Adapter into the POWER IN (DC) socket next to the ON/OFF switch on the rear panel. Then plug both AC Power Adapters into suitable wall sockets. Plug your TV or monitor into another AC wall socket and switch it on.

6 Turn on the disk drive(s). Both the POWER light (next to the ON/OFF switch) and the BUSY light (above the switch) will go on. When the BUSY light goes off, you are ready to insert a disk.

Your disk drive is now ready to receive the A-TRACK Master Disk. It is recommended that you read the next section carefully before proceeding.

Taking Care of Your Disks

Atari disk drives use 5.25" double-sided, double-density (DSDD) disks which have a nominal capacity of 360 Kbytes. However, the Atari disk drives only record on one side of the disk at a time, and use single-density recording, so that they store only 90 Kbytes per side (in 720 sectors each of 128 bytes). The 1050 disk drive can also store at enhanced-density, which manages 128 Kbytes on each side.

The surface of a disk is coated with a sensitive magnetic material that stores your data. To ensure the long life and reliability of your disks, you must handle them properly and with care.

Each disk is permanently enclosed in a black protective envelope and is normally stored in a paper sleeve. Most disks have a small write-protect notch on one edge of the black protective envelope. By covering this notch with one of the small adhesive rectangular tabs provided by the disk manufacturer, you can avoid accidentally erasing or writing over any data on a disk.

Remember these rules for the proper care and handling of disks:

- ◆ Never turn your disk drive on or off with a disk in the drive, and never leave a disk in the drive while it's turned off.
- ◆ Never wet or wash a disk. Use a soft brush or compressed air from a spray can to remove any dust from the surface.
- ◆ Do not bend your disks - they must turn freely in the protective envelope. Handle them with care when loading or unloading.
- ◆ Store disks in their paper sleeves standing on edge.
- ◆ Store your disks away from your television set or monitor. The strong magnetic fields produced by these devices can partially erase the data stored. Keep your disks away from electrical devices, including the telephone.
- ◆ Do not store your disks in direct sunlight. Keep them away from any excessive heat.
- ◆ Because a disk turns inside its envelope, damage to the envelope can result in damage to the disk.
- ◆ Do not write on your disks with a pencil or ball-point pen. The sharp point of a pencil or ball-point pen can score the surface of a disk. Use a felt-tip pen to mark the disk label or write on the label before you put it on the disk.
- ◆ Do not use erasers on disk labels. Eraser dust is abrasive and will damage disks.
- ◆ Do not attach paper clips to your disks.
- ◆ Never touch a disk where it is exposed through the disk envelope. Fingerprints can damage the magnetic medium.

Most disks come with labels already affixed to one corner of the black protective envelope or with a set of labels that you can attach to each disk. Be sure to label every disk on which you copy or store programs and files.

12.2 ATARI DOS 2.5

Your Atari computer's memory retains the information and instructions you enter through its keyboard. However, the computer's memory is limited in size, and without a storage device like the 1050 Disk Drive, its contents are erased each time you turn off the computer.

Your disk drive enables you to store and manage large amounts of information in separate files on disks. Through the disk drive, you can call up your files by name, copy or erase them, and manage them in many other ways.

To store information on disks you need software that allows your computer and disk drive to communicate with each other about your files. That is where the Disk Operating System - DOS (pronounced "doss") for short - fits into the picture. DOS is a program that enables your computer and disk drive to work together in storing, retrieving, and otherwise managing your disk files. DOS itself is organized in two files contained on the A-TRACK Master Disk, **DOS . SYS** and **DUP . SYS**.

DOS must be loaded into your computer before it can work with your disk drive. This is done automatically when you switch the computer on with a disk, containing the DOS files, loaded into the disk drive. DOS performs many essential tasks, such as preparing blank disks to store your files, for example, and to make backup copies of important files and disks.

At this stage you should have your Atari system connected up with the TV or monitor and the disk drive switched on and with the BUSY light off. **CAUTION:** Never insert a disk into your drive, or remove a disk from it, while the BUSY light is on.

Turn the latch on the front of whichever disk drive is set to be Disk Drive 1 to the open (horizontal) position. Remove your A-TRACK Master Disk from its protective paper sleeve and insert it in your drive, with the label facing up and toward you, until it clicks into place. Then turn the latch clockwise to the closed (vertical) position. The drive will make a whirring sound and the BUSY light comes on. After a few seconds, the noise should stop and the BUSY light go off.

Turn on your computer. The disk drive's BUSY light will come on again as DOS loads into your computer, and the drive makes a clicking sound. If you turn up the sound volume on your TV or monitor, you should hear a series of beeps as DOS loads.

If all goes well, you will see the **READY** prompt appear on the TV or monitor screen, showing that the Atari BASIC programming system is active. Now type 'DOS' (three letters) on the keyboard and press **RETURN** to bring up the Atari DOS 2.5XL Menu.

Since you do not need BASIC to handle your disk files or operate the A-TRACK program, you can prevent it loading by holding down the **OPTION** key (to the right of the keyboard) as you switch on the computer - press **OPTION** before turning the Power Switch to ON, and keep it held down until text appears on the screen. If you do this, the DOS Menu will appear immediately loading is complete.

Boot Errors

Loading a program into a computer when you first turn it on is called "booting up". If a problem occurs when booting up your system, the prompt **BOOT ERROR** appears on your screen. This can happen for a number of possible reasons -

- ◆ The inserted disk does not have DOS on it.
- ◆ The disk was inserted incorrectly.
- ◆ The disk has been scratched, warped, or marred. In this case, use another disk.
- ◆ The disk is an enhanced-density disk in an Atari 810 Disk Drive.

The following conditions will also cause a boot error, but no indication of it will appear on the screen -

- ◆ The disk drive was turned on after the computer was turned on.
- ◆ The disk drive is not properly connected to the computer console.
- ◆ The Power Adapter plug has loosened from its wall socket.
- ◆ The Power Adapter plug has loosened from the disk drive POWER IN socket.
- ◆ The drive code setting is not correct.

If you have checked and found none of these problems, take the following steps:

- 1 Insert an Atari DOS 2.5 Master Disk or System Disk (one with a working copy of DOS 2.5 which you should have received with your Atari system) into Drive 1 and reboot the system.

- 2 Remove the DOS disk.
- 3 Reinsert the problem disk and save any accessible files on another disk using the process for copying files (see **C. COPY FILE**, later in this Section).
- 4 With the problem disk in Drive 1, use the **D. DELETE FILE(S)** function to erase all the files.
- 5 Try using the disk again. If this fails, the disk will have to be reformatted (see **I. FORMAT DISK**, later in this Section) or discarded.

The DOS Menu

Once you've loaded DOS into your computer and, if necessary, typed **DOS** and pressed **RETURN**, the DOS Menu appears on your TV or monitor screen. The menu presents a list of DOS functions. The prompt below the menu invites you to make a selection. You choose the function you want to use by pressing the letter corresponding to your selection and pressing **RETURN**.

DOS then asks you for the information it needs to proceed (see "Prompts and Responses," later in this section).

The DOS 2.5 Menu options presented on the screen have the following purposes -

A. DISK DIRECTORY

This option allows you to call up a complete or selective list of the files on a disk, showing the filenames, extenders (if any), the number of sectors allocated to each file, and the number of free sectors still available on the disk.

B. RUN CARTRIDGE

This option allows you to return control of your system to the built-in BASIC Programming System (provided you have not disabled it with the **OPTION** key - in this case re-boot the computer).

C. COPY FILE

Use this option when you have two or more disk drives and you want to copy files from one disk to another. Also use this option to copy a file on the same disk, assigning a second name to the copy.

D. DELETE FILE(S)

This option lets you erase a file from a disk, increasing the available space on the disk.

E. RENAME FILE

Use this option when you want to change the name of a file.

F. LOCK FILE

This option can be used to prevent you - or anyone else - from changing, renaming, or accidentally erasing a file. You will still be able to read the file, but will not be able to write to it. When the directory is displayed, an asterisk is placed in front of the filename to indicate that the file is locked.

G. UNLOCK FILE

This removes the asterisk from in front of the filename and allows you to make changes to the file, rename it, or delete it.

H. WRITE DOS FILES

Use this option to add the DOS files (**DOS.SYS** and **DUP.SYS**) from your Master Disk or System Disk to a disk in any disk drive.

I. FORMAT DISK

This option is used to format a blank disk, which is necessary before you can record any information on it. Be sure you do not have any files you want to keep on a disk before formatting it. This option will format a disk in enhanced density provided you are using a 1050 Disk Drive - otherwise, it will format in single density.

J. DUPLICATE DISK

This is the option you choose when you want to create an exact duplicate of a disk. This option will automatically format the destination disk.

K. BINARY SAVE

With this option you can save the contents of specified memory locations to a disk file. (Used when developing assembly language programs.)

L. BINARY LOAD

This option lets you retrieve an object file from a disk. It is the reverse function of BINARY SAVE. (Used when developing assembly language programs.)

M. RUN AT ADDRESS

With this option you can enter the hexadecimal starting address of an object (assembly language) program, after it has been loaded into memory (RAM) with a BINARY LOAD, and start it executing.

N. CREATE MEM.SAV

This option allows you to reserve space on a disk for the program in RAM to be stored while the **DUP.SYS** file is being used (Amongst other functions, **DUP.SYS** is responsible for the display of the DOS Menu you are currently viewing on the screen). This option is not required with DOS 2.5XL which uses an otherwise wasted area of memory to hold **MEM.SAV**.

O. DUPLICATE FILE

This option enables you to copy a file from one disk to another, even if you have only a single disk drive.

P. FORMAT SINGLE

Use this option when you want to format a disk in single density using a 1050 Disk Drive.

Prompts and Responses

The questions and requests that DOS displays on your screen are called prompts. The answers you type into your computer are responses. DOS always prompts you for the information it needs to carry out your wishes. You will soon become familiar with the most common DOS prompts and, since DOS requires the same kind of information for many of its functions, it won't be long before many of your responses become almost automatic. As you

use each function of DOS, the program lists its successive prompts and your responses on your screen as you proceed.

After typing a response into your computer, you must press **RETURN** to confirm your response. (Pressing **RETURN** only in response to certain prompts tells DOS to supply a preselected, or default, response as explained below. Many prompts require a simple 'yes' or 'no' answer. To answer 'yes', type **Y** and press **RETURN**. To answer 'no', type **N** and press **RETURN**.

If you make a mistake while typing in a response, press **DELETE-BACKSPACE** to erase the error, then type in the correct information. To delete an entire response before you confirm it, press **SHIFT** and **DELETE-BACKSPACE** simultaneously.

Looking at a Disk Directory

Each disk you use to store information has a disk directory that keeps track of the files stored on the disk, how much room they take up, and how much free space is left on the disk for storing more information. The DISK DIRECTORY selection on the DOS Menu allows you to check what files you have on your disks.

Since your A-TRACK Master Disk itself contains files, you can try out the function by looking at the directory of those files. Ensure that you still have the A-TRACK Master Disk in Drive 1 then, with the DOS Menu on your screen, type **A**, then press **RETURN** twice.

A list of files on the A-TRACK Master Disk should appear as follows -

```
* DOS      SYS 037
* DUP      SYS 042
* RAMDISK  COM 009
* ATRACK   COM 033
* ATRACK   OVL 179
* ATRACK   FNT 009
* ATRACK   CFG 001
* ATRKDEMOITL 038
* REALINITITL 022
337 FREE SECTORS
```

The three-digit numbers in the right-hand column indicate how many sectors each file occupies on the Master Disk - don't worry if some of the numbers on the screen differ from those above - A-TRACK and its associated files are being updated fairly frequently! The line below the last file description tells you how many sectors remain for storing additional information on the disk. The asterisk preceding each file name indicates that the files are locked, so that they are protected from being altered or erased, but can still be read or copied.

DOS .SYS and **DUP .SYS** are the files that execute the standard DOS functions.

RAMDISK .COM is used if you have an Atari 130XE, or an 800XL with additional (extended) memory, to utilise the extra memory as a super-fast disk drive lookalike (Drive 8) known as a 'RAM Disk'. You can use Drive 8 to save and load files more quickly than a real disk drive **BUT** any files you hold there will disappear as soon as the computer is switched off (or its power fails). You will have to copy any files you wish to preserve on to a real disk before

switching off. If you have only a normal 800XL (or do not wish to use a RAM Disk) then you need not copy **RAMDISK.COM** to your A-TRACK Working Disk.

The other files listed are associated with the A-TRACK system as described in Section 3.1. **REALINIT.ITL** is an A-TRACK Item List containing actual DCC Decoder parameters used by the author for program development.

Duplicating a Disk

With the DUPLICATE DISK option on the DOS 2.5 Menu, you can create an exact replica of a disk. This function copies everything from your original, or source, disk onto another, or destination, disk. It also formats your destination disk.

CAUTION: The DUPLICATE DISK function erases or writes over any information that may already be on a destination disk. Never use a destination disk that contains valuable files.

To learn how the DUPLICATE function works, make a duplicate of your A-TRACK Master Disk. This is also an important safeguard. You should use your duplicate as your working copy of A-TRACK, and keep the Master Disk itself as a backup copy. Then you can use A-TRACK without worrying about accidental damage to your working disk.

As your destination disk, use a new, blank disk and, to prevent accidents, ensure that the write-protect tabs (the small self-adhesive foil rectangles attached to the edges of the disk near the label) are firmly in place on the Master Disk (but **NOT** on the blank disk).

If You Have One Disk Drive -

- 1 With the DOS Menu on your screen, type **J** and press **RETURN**. The prompt **DUP DISK-SOURCE,DEST DRIVES?** appears.
- 2 Type **1,1** and press **RETURN**. The prompt **INSERT SOURCE DISK, TYPE RETURN** appears.
- 3 Place the disk you want to duplicate in the drive - in this case, your A-TRACK Master Disk - and press **RETURN**. The disk drive begins to "read" the information contained on your source disk. Then DOS prompts you to **INSERT DESTINATION DISK, TYPE RETURN**.
- 4 Remove your source disk from the disk drive and insert the blank disk (formatted or unformatted), then press **RETURN**. DOS writes the information it has read from your source disk to your destination disk, first formatting the destination disk.

How many times DOS prompts you to insert your source and destination disks in your disk drive will depend on how much data is recorded on the source disk and the amount of RAM in your computer system. When the prompt **SELECT ITEM OR RETURN FOR MENU** appears, the duplication process is complete.

If You Have Two Disk Drives -

- 1 With the DOS Menu on your screen, type **J** and press **RETURN**. The prompt **DUP DISK - SOURCE, DEST DRIVES?** appears.
- 2 Type **1,2** and press **RETURN**. The prompt **INSERT BOTH DISKS, TYPE RETURN** appears.
- 3 Place your source disk in Drive 1 - in this case, your original A-TRACK Master Disk - and a blank disk (formatted or unformatted) in Drive 2, then press **RETURN**.
- 4 DOS duplicates all the information from your source disk on your destination disk, first formatting the destination disk.

When the prompt **SELECT ITEM OR RETURN FOR MENU** appears, the duplication process is complete.

Label your new copy of A-TRACK clearly - something like " A-TRACK Working Disk". Attach a write-protect tab to it, folded over the notch in the edge of the disk, to prevent your disk drive from writing information over any of the files that you have just copied there, then use it as your working copy of A-TRACK from now on. Store your original A-TRACK Master Disk in a safe place - well away from any stray magnetic fields.

The DUPLICATE DISK function is sometimes confused with the COPY FILES function of DOS. The COPY FILES function copies only the files you specify from a source disk. The DUPLICATE DISK function is more efficient when you want to make complete backup copies of data disks containing several files.

Formatting a Disk

Unless they're preformatted, the disks you buy to store your files must be prepared to record information from your computer. This process is called formatting, or initializing, a disk. Formatting organizes the surface of a disk into tracks and sectors so that your computer can store and retrieve information on it in an orderly way.

CAUTION: Formatting a disk erases any information that may already be recorded on it. Never format your Master Disk or a data disk that contains valuable files.

The DOS 2.5 Menu offers you two options for formatting disks. When used with a 1050 Disk Drive, Option **I . FORMAT DISK**, will format the disk in enhanced density. If DOS finds, when executing this function, that the drive you have specified for formatting is an 810, it will proceed to format the disk in single density. Option **P . FORMAT SINGLE**, formats only in single density. It should be used when you want to format a disk in single density on a 1050 Disk Drive.

Note that the A-TRACK Master Disk is formatted in single density so that it can be read in any Atari drive. You can copy its files to, and use them from, an enhanced density disk if you so wish without any problems.

To get acquainted with the formatting procedure, with the DOS Menu on your screen, format two blank disks (to use when doing the exercises described below) as follows -

- 1 To format in enhanced density on a 1050 Disk Drive, type **I** and press **RETURN, OR**, to format in single density, type **P** and press **RETURN**. The prompt **WHICH DRIVE TO FORMAT?** appears.
- 2 Type the number of the disk drive in your system in which you want to format the disk. The prompt **TYPE "Y" TO FORMAT DISK n** (where **n** is the number of the drive you specified) appears. This gives you a chance to make sure that the specified drive contains a disk that you want to format - remember, formatting erases any files already contained on a disk.
- 3 Place the disk to be formatted in the drive you have specified. Type **Y** and press **RETURN**. The BUSY light goes on as the drive begins to format the disk.

When the prompt **SELECT ITEM OR RETURN FOR MENU** appears, formatting is complete. You can now store files or write DOS Files on the formatted disk.

Now repeat the procedure with another disk.

Naming and Referring to Files

To manage your files with DOS, you have to give each file a distinctive filename. You also have to use a device code to tell your computer what part of your system - for example, Disk Drive 1 - you want to handle the file at any particular time. Taken together, the device code and the filename that you specify make up a filespec (short for "file specification"). Here is what a typical filespec looks like -

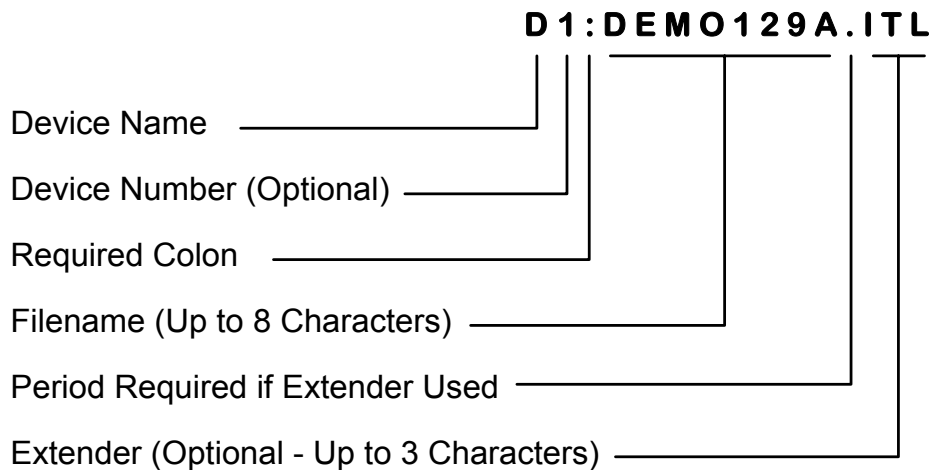

Defaults

For your convenience, DOS 2.5 provides default responses to several of its own prompts.

Since most DOS users have only one disk drive, for example, one of the more convenient defaults in DOS is **D1:** - Disk Drive 1 of your computer system. You have seen how DOS defaults to this device when you press **RETURN** in response to a **DIRECTORY- SEARCH SPEC, LIST FILE** prompt. DOS also defaults to **D1:** as a source and destination device

You can now understand the entire default filespec used by DOS in a DISK DIRECTORY procedure. When you press **RETURN** in response to the **DIRECTORY - SEARCH SPEC, LIST FILE** prompt, DOS understands your response as **D1: *.***. The **D1:**, as you know, is the default device code (Disk Drive 1), and the ***.*** stands for all files on the disk you want to check, inserted in Drive 1.

Copying Files

With the **COPY FILE** and **DUPLICATE FILE** options on the DOS Menu, you can copy your files from one disk to another. You can also make a backup copy of a file on the same disk as the original, provided you give the copy a different filename.

NOTE: You cannot copy the files that make up DOS - **DOS.SYS** and **DUP.SYS** - using either **COPY FILE** or **DUPLICATE FILE**. Instead, use Option **H. WRITE DOS FILES**, to copy these files. Normally, if you wish to put the DOS files on a disk (so that you can boot the computer from it) you would do this immediately after formatting the disk, and before copying any other program or data files to it.

The easiest way to learn how to copy files is to use the existing files on the A-TRACK Working Disk which you should have created as part of the **DUPLICATE DISK** exercise described previously.

Which of the two copying options you should use depends on how many disk drives you have and whether you want to copy a file from one disk to another, or to replicate it on the same disk.

From One Disk to Another With One Disk Drive -

- 1 With the DOS Menu on your screen, type **O** for **DUPLICATE FILE** and press **RETURN**. The prompt **NAME OF FILE TO MOVE?** appears.
- 2 Type the name of one of the A-TRACK files - say, **ATRACK.COM** - and press **RETURN**. The prompt **INSERT SOURCE DISK, TYPE RETURN** appears.
- 3 Place the disk containing the file you want to duplicate in the drive and press **RETURN**. The disk drive begins to read the specified file on your source disk. Then DOS prompts you to **INSERT DESTINATION DISK, TYPE RETURN**.
- 4 Remove your source disk from the disk drive and insert one of your formatted (blank) disks, then press **RETURN**. DOS writes the file it has read from your source disk to your destination disk.

How many times DOS prompts you to insert your source and destination disks in your disk drive will depend on how large your original file is. Try copying a large file like **ATRACK.OVL** to see the effect - be careful not to get source and destination disks confused. If you do manage to swap source and destination disks at any stage you will appreciate the precaution of placing a write-protection tab on the source disk. When the prompt **SELECT ITEM OR RETURN FOR MENU** appears, the copying process is complete.

From One Disk to Another With Two Disk Drives -

- 1 With the DOS Menu on your screen, type **C** for COPY FILE and press **RETURN**. The prompt **COPY - FROM, TO?** appears.
- 2 Type the complete filespec for the file you want to copy, a comma, and the filespec for the copy itself. To copy the practice file **ATRACK.COM**, you could type -
D1:ATRACK.COM,D2:ATRCKCOM.CPY - or simply use the same filespec for the copy.
- 3 Make sure that the disk containing your original file is in Drive 1 and the disk to which you are copying is in Drive 2. Then press **RETURN**.

DOS copies the specified file from the disk in Drive 1 to the disk in Drive 2. When the prompt **SELECT ITEM OR RETURN FOR MENU** appears, the copying process is complete.

Backing Up a File on the Same Disk

Whether you have one drive or two, you use the COPY FILE option on the DOS Menu to make a backup copy of a file on the same disk. Follow the steps outlined above for the two-drive copy, but type the same drive code for both the FROM and the TO filespecs and remember to give the file a different name in the TO filespec. For example, if you are copying the file **ATRACK.COM** on Drive 1, you might type -
D1:ATRACK.COM,D1:ATRACK.BAK.

Using Wild Cards to Copy a Group of Files

Suppose you want to make backup copies of all four of the A-TRACK files - **ATRACK.COM**, **ATRACK.OVL**, **ATRACK.FNT**, and **ATRACK.CFG**. You can use wild cards to copy all four at once - a time-saving alternative to copying them one at a time.

To use wild cards to copy all your practice files, follow the same procedure you use to copy one file on your system, but use wild cards when typing your FROM filespec (when using COPY FILE) or your NAME OF FILE TO MOVE (when using DUPLICATE FILE). To copy all four files, for example, you would type **ATRACK.*** as the name of the files to be copied - using the * to stand for the extenders in all four filenames. If you are using the DUPLICATE FILE option, DOS will tell you as it copies each file.

Erasing Files

You can erase a file from a disk with the DELETE FILE(S) function on the DOS Menu. Erasing out-of-date files, of course, opens up space on your data disks for storing more information. After a file is erased from a disk, its filename disappears from the directory for that disk.

CAUTION: Use the DELETE FILE(S) function with care - it may be permanent.

For practice, try erasing the copy you made of your **ATRACK.COM** file. Place the data disk containing the file in your disk drive. Then follow these steps:

- 1 With the DOS Menu on your screen, type **D** and press **RETURN**. The prompt **DELETE FILESPEC** appears.
- 2 Type **D1:ATRACK.COM** if your data disk is in Drive 1, or **D2:ATRACK.COM** if it is in Drive 2, then press **RETURN**. The prompt **TYPE "Y" TO DELETE...** appears - this is a verification prompt, allowing you a chance to change your mind about erasing the file.
- 3 Type **Y** and press **RETURN** to erase the file.

With wild cards in your filespec, you can erase as many files as you wish in one operation. To try this, copy a number of files to one of your disks, all with **.BAK** as an extender. Follow the same procedure you use to erase one file, but when your computer prompts you to enter the DELETE FILESPEC, type **D1:* .BAK** (or **D2:* .BAK** if you are using Drive 2).

As DOS displays each filename matching your filespec, type **Y** and press **RETURN** to delete that file. When you want to erase several but not all of the files in a group that you specify with wildcards, simply type **N** and press **RETURN** as the name of each file that you want to preserve appears. This operation takes less time than going through the entire DELETE FILE(S) procedure for several individual files.

12.3 ATARI ERROR CODES

As well as the error codes specific to A-TRACK (201 through 206) you may occasionally see some errors on the Status Row reported directly by the Atari XL/XE operating system, particularly when performing File operations or during the load of the A-TRACK program itself. A full list of the error codes which can be generated by the more-common Atari disk operating systems (Atari DOS 2.5, MyDOS, and SpartaDOS) are given below (with the A-TRACK codes for completeness).

003	Last Byte of File	160	Invalid Drive Number
128	Break Abort	161	Too Many Open Files
129	Input/Output Control Block (IOCB) Already Open	162	Disk Full
130	Non-Existent Device Specified	163	Read Fail/Illegal Wildcard in Filename
131	File/IOCB Write Only	164	File Link Fail/Erase Protected
132	Invalid Handler/IOCB Command	165	Invalid Characters in File Name
133	Device/File Not Open	166	Invalid POINT Command Request
134	Invalid IOCB Number	167	File/Directory Locked
135	File/IOCB Read Only	168	Invalid Command/IOCB
136	End of File	169	Directory Full/Disk Write Locked
137	Truncated Record (>256 Bytes)	170	File Not Found
138	Device Timeout (No Drive Found)	171	IOCB/POINT Invalid
139	Device Not Acknowledged (No Disk - Wrong DOS)	172	Duplicate File/Directory Name
140	Serial Framing Error	173	Disk Bad/Format Fail
141	Cursor Out of Range	174	Directory Not Found/ Duplicate Filename
142	Serial Bus Data Frame Overrun	175	Directory Not Empty/Bad Load
143	Serial Bus Data Frame Checksum Bad	176	Incompatible Format
144	Device I/O Error (Disk Bad or Write Protected)	177	Disk Structure Damaged
145	Read After Write Error	180	Not Binary File
146	Function Not Implemented	181	Invalid Address Range
147	Insufficient Memory	201	Unable to Generate DCC Command
148	Not SpartaDOS Disk	202	Invalid Data Entered
149	Not SpartaDOS 2.X Disk	203	DIU Not Enabled
150	Directory Not Found	204	DIU/PBU Not Active
151	File/Directory Already Exists	205	DCC Command Block Not Output
152	Not Binary File	206	DIU Not in Program Mode

Usually the cause of the error is fairly obvious - equipment not connected or switched on, no disk (or the wrong disk) in the drive, disk not formatted, or a simple typing error in the filename, etc. - and can be easily rectified. However, if a careful check of connections followed by a system reload does not fix the problem, you should check your Atari equipment on its own, running some other (known good) software, to try to identify whether it is the Atari kit or A-TRACK which is at fault before looking for further assistance.

13 CHANGE HISTORY

13.1 RELEASE 2.0 (SINCE RELEASE 1.2)

- 1 All Item Addresses are now displayed as decimal values on the List Screen so you can relate them directly to your locomotive cab numbers.
- 2 Consist Address is displayed as a decimal value on the Control Screen.
- 3 Function states are now updated immediately on the Control Screen when the displayed Item is under Handheld control.
- 4 After editing or marking a Configuration Value on the Program/Verify Screen the cursor is moves to the next CV Value. When moved by the Arrow keys, the cursor also wraps around, ie. from the bottom of a column back to the top, or from the right-hand end of a row back to the left end. This makes it easier to mark a large number of values, or move to any specific value with a lot fewer keystrokes.
- 5 Access to Item Type and Description fields is now disabled in Verify Mode.
- 6 Code to handle the functions of both Enhanced Atari Paddles and A-TRACK Handheld Controllers has been added.
- 7 Configuration (Amend) options have been added to accommodate A-TRACK Handheld Controllers.
- 8 Colour coding of A-TRACK Handheld Controllers is shown on the Control Screen.
- 9 DIU output is now disabled during Item List (File) Load and Save.
- 10 Screen cursors are now correctly initialised after loading a new Item List.

13.2 RELEASE 2.2

- 1 Use of A-TRACK Handheld Controllers has been improved by allowing the Speed Control Mode (Centre-Zero or Directional) to be set individually for each Handheld. Choice of mode is made on the Control Screen instead of during A-TRACK Configuration.
- 2 A Network Driver unit has been introduced to obtain reliable operation of A-TRACK Handhelds when connected to a cable network. Use of either 8-core telephone cable or Category 5 UTP (quad unscreened twisted-pair) cable for the network proved in operation.
- 3 A bug on the Control Screen, allowing reassignment of a Loco from one Handheld directly to another Handheld (without assigning to 'None' first), has been corrected.
- 4 Change of Speed Step Precision can only be done now when the Loco or Consist assignment is 'None', to avoid generation of invalid commands.
- 5 Colour naming of 'Mauve' for A-TRACK Handhelds (**H5**) has been changed to 'Violet' in line with standard coding practice.

14 AFTERWORD

A-TRACK is still a work in progress. Any comments, criticisms, or suggestions regarding any aspect of the operation, functions, or useability of the program and the hardware are welcome and will be given careful consideration.

Terry Chamberlain

9 Coniston Way
Macclesfield
Cheshire, SK11 7XR
England

Telephone: +44 (0) 162 542 1324

E-mail : tchamberlain@a-train.freemove.co.uk
100116.2152@compuserve.com

23 March, 2000