



Reference Manual

Version 4.4.1

CONTENTS

1	A-TRACK AND YOUR NCE DCC SYSTEM.....	5
1.1	Principal Features of A-Track.....	5
1.2	Safeguard Your DCC Decoder Configurations.....	8
1.3	Gain Centralised Control of Your Layout.....	8
1.4	Protect Your Decoders, Command Station & Handheld Cab Setups.....	9
1.5	Additional Facilities.....	10
1.6	Obtaining Your Copy of A-Track.....	10
2	SYSTEM REQUIREMENTS.....	11
2.1	Personal Computer.....	11
2.2	Operating System.....	11
2.3	DCC Command Station.....	12
3	GETTING STARTED.....	13
3.1	Installation from the Full Installation Package.....	13
3.2	Installation from the Distribution CD.....	14
3.3	Installation from the Setup File.....	16
3.4	Installing A-Track Step-by-Step.....	16
3.5	Starting the Program.....	26
3.6	An Introductory Tutorial.....	33
3.7	Making a Quick Start.....	35
4	ITEMS AND ITEM LIST OPERATIONS.....	42
4.1	Accessing and Viewing Item Lists.....	43
4.2	Item List Load and Save Options.....	50
4.3	Other File and Program Functions.....	56
4.4	Editing - Undo, Redo, Find, and Selection.....	57
4.5	Editing - Cut, Copy, and Paste.....	60
5	GENERAL ITEM OPERATIONS.....	64
5.1	Edit Configuration Variables Window.....	64
5.2	Setting Key Item Parameters.....	66
5.3	Initialising a Blank Item.....	72
5.4	Editing CV Values Directly.....	80
6	LOCOMOTIVE ITEM OPERATIONS.....	82
6.1	Speed and Speed Tables.....	82
6.2	Functions and Function Mapping.....	91
6.3	Accessing Further CV Pages - Sound and Complex Functions.....	93
6.4	Serial User Standard Interface (SUSI).....	103
6.5	Transferring CV Values Between Items.....	104
6.6	Reading and Verifying CV Values.....	107
6.7	Programming CV Values.....	114
6.8	Control - Allocation of Locomotive Items.....	118
6.9	Control - Direct Operation of Locomotive Items.....	128
6.10	Emergency Stop.....	133
6.11	Defining and Assigning Locomotives to Consists.....	138
6.12	Transferring and Activating Consists.....	151
6.13	Controlling Consists.....	167
7	ACCESSORY ITEM OPERATIONS.....	168
7.1	Accessories - Operation and Parameters.....	168
7.2	Accessory Decoders - Linking Turnouts.....	179
7.3	Programming Accessory Decoders - Edit CVs Window.....	184
7.4	Controlling Accessory Decoders.....	191
7.5	Programming Accessory Decoders - Control Window.....	199
7.6	Using Macros to Control Accessories and Set Routes.....	202

7.7	Defining, Editing and Saving Macros.....	203
7.8	Transferring Macros	216
7.9	Linking Macros	224
7.10	Macro Group Operations	230
7.11	Executing Macros and Running Routes.....	236
8	LAYOUT MIMIC DIAGRAMS AND TURNOUT CONTROL	241
8.1	Constructing, Saving and Loading Mimic Diagrams.....	241
8.2	Block Editing, Printing and Sorting of Mimic Diagrams	263
8.3	Handling of Turnouts and Display of Routes	271
8.4	Monitoring Turnout Positions	272
8.5	Finding and Setting Routes	293
8.6	Using Mimics with 'Single-Click' Settings.....	306
9	NCE COMMAND STATION AND CAB OPERATIONS.....	308
9.1	Command Station Data Backup and Restore	309
9.2	Command Station Setup and Status.....	321
9.3	Viewing Consist Backup Files.....	329
9.4	Handheld Cab Setup and Status	333
9.5	Using Handheld Cabs without an LCD Display	342
10	PRINTING LISTS AND ITEM DETAILS.....	343
10.1	Output Formats	344
10.2	Direct Printing of an Item Summary	345
10.3	Direct Printing of Item Details	346
10.4	Printing to a Text File	352
10.5	Printing Consist and Accessory Details.....	357
10.6	Printing Route Macro Lists and AIU Allocations.....	360
11	REGISTRATION AND SUPPORT	365
11.1	Registration and Activation	365
11.2	Obtaining Support and Reporting Problems	372
11.3	Checking for A-Track Updates	376
12	A-TRACK MENUS - REFERENCE.....	382
12.1	File	383
12.2	Edit.....	385
12.3	View	387
12.4	Item	390
12.5	NCE	391
12.6	Route.....	393
12.7	Mimic.....	393
12.8	Help.....	394
12.9	Pop-Up.....	396
13	INSTALLATION OF USB-TO-SERIAL INTERFACES.....	397
13.1	NCE USB Interface Unit	401
13.2	Keyspan USA-19HS USB-to-Serial Adapter.....	405
13.3	USB-to-Serial Adapters using Prolific Chipsets	410
13.4	Links to USB-to-Serial Interface Vendors	417
14	USING NCE AUXILIARY INPUT UNITS.....	420
14.1	Set-Up and Electrical Connections.....	420
14.2	Links to Turnouts with Power-Switched Frogs	423
15	A-TRACK REVISION HISTORY	430
16	A-TRACK END-USER LICENCE AGREEMENT.....	442

NCE, Power Cab, Smart Booster, DCC Twin, Power Pro, PH Pro, ProCab, Cab04, Cab05, Cab06 and the NCE logo are trademarks of NCE Corporation, Copyright © 1994 - 2019

Disclaimer

I hope you will like the A-Track for Windows program and enjoy using it as much as I have enjoyed creating the system, BUT . . .

While every effort has been made to thoroughly test and verify all functions incorporated into the A-Track for Windows application software when interfaced to the appropriate NCE hardware, please note that the software is supplied on an "as is" basis and without any warranty that it will perform faultlessly in your application. You use the A-Track for Windows application software and all associated hardware items at your own risk, and in accordance with the full terms of the end-user licence agreement which can be found in Chapter 16 of this document.

The author and designer will not in any event be held liable for any improper operation of the A-Track for Windows program, or interference with any other equipment or software program, nor be held liable for any incidental or consequential damages of any sort arising out of its use.

Terry Chamberlain

February 2019

Acknowledgements

While all of the program code involved in the various parts of A-Track was written from scratch, using Visual Basic 6 (and some C), the author would like to acknowledge the inspiration provided by the work of the Java Model Railroad Interface (JMRI) group who showed what could be done when a PC is interfaced to commercial DCC equipment. Solving similar problems for yourself is made a lot easier by knowing that someone else has already found a solution – even if you do not understand exactly how they did it !

Thanks are especially due to Mark Gurries, of JMRI and formerly of the Silicon Valley Lines Model Railroad Club, who collected all of the publicly available NCE documentation together in his System Technical Manual, and continues to add to this data in his web pages. A-Track could not have advanced as far as it has done without this invaluable reference material.

The author would also like to thank the members of the Cochise and Western Model Railroad Club of Sierra Vista, AZ for their assistance in testing and using A-Track under real operating conditions - and for their patient support and help in ironing out the many bugs that cropped up during development. Particular thanks are due to their long-serving Secretary, Charles Cole, who sadly passed away in October 2015. Charles was involved with A-Track from its very early beginnings on an Atari home computer in 1996 and was a constant source of help and useful insights into what model railroaders really wanted.

NCE Corporation was not involved in the creation or development of A-Track.

1 A-TRACK AND YOUR NCE DCC SYSTEM

As you may have noticed, this Reference Manual is a fairly large document which describes all features of A-Track in detail. You are not expected to read all of it before using A-Track, but rather to dip into it as required when you want to use specific A-Track facilities. For the key points that you do need to know before getting to grips with the program see the Installation Notes and the User Guide.

1.1 Principal Features of A-Track

A-Track for Windows (A-Track) is a powerful FREE extension to complement the facilities of your NCE Corporation Power Cab or Power Pro Digital Command Control system and to assist you in running your roster of locomotives on your model railroad. A-Track allows you to store full details of all of your locomotives and accessory (turnout) decoders, with all of their DCC configuration parameters, in a readily-accessible format on a personal computer – but without requiring you to be any kind of computer expert.

A-Track's back-up copy of all of the data held within each DCC decoder fitted in the locomotives which make up your roster, safeguards all the hours of effort put in by you (or your Club's DCC expert) in programming and configuration. When linked to your NCE system, A-Track does not alter the way in which the NCE Command Station and Handheld Cabs operate, or are connected to the track and to each other, in any respect, so that you can continue to use them exactly as before – but with A-Track available to lend a powerful helping hand in the background.

A-Track is a software application which runs, under Windows XP, Windows Vista, Windows 7, Windows 8 (including 8.1), or Windows 10 on a standard Personal Computer (PC). When using an NCE Power Cab system (including systems based around an NCE SB3a or SB5 Smart Booster unit, or the entry-level DCC Twin), A-Track is connected to your system via an NCE USB Interface unit, as shown in the example set-ups below for the different NCE systems –

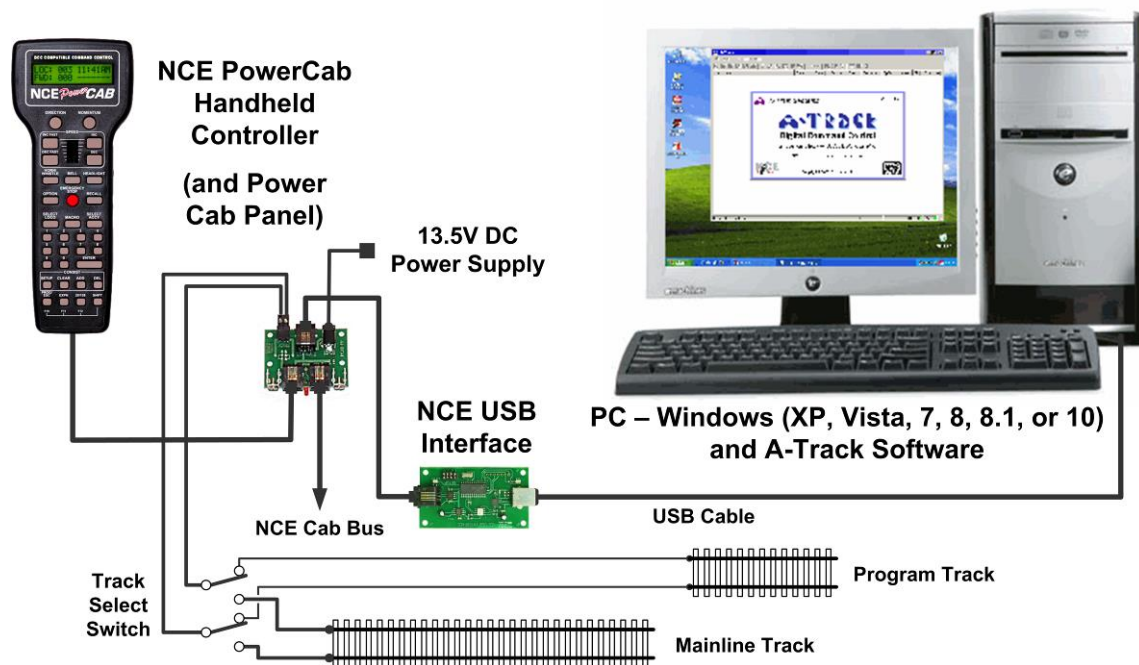

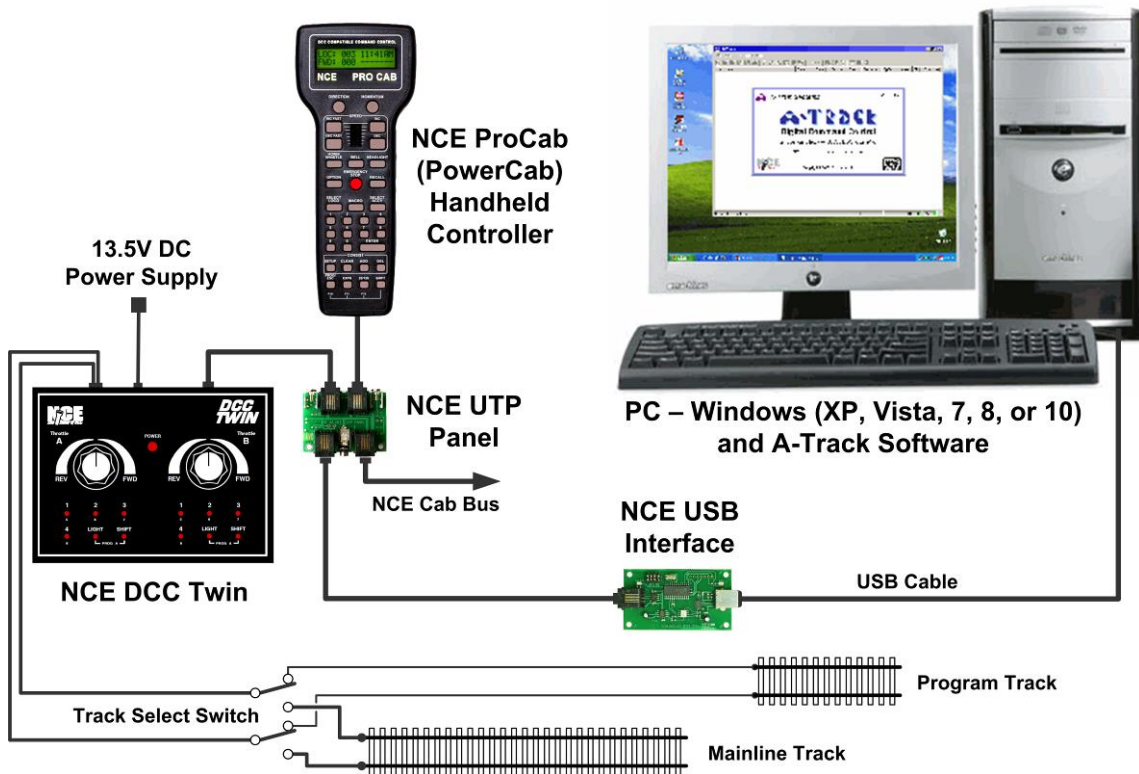
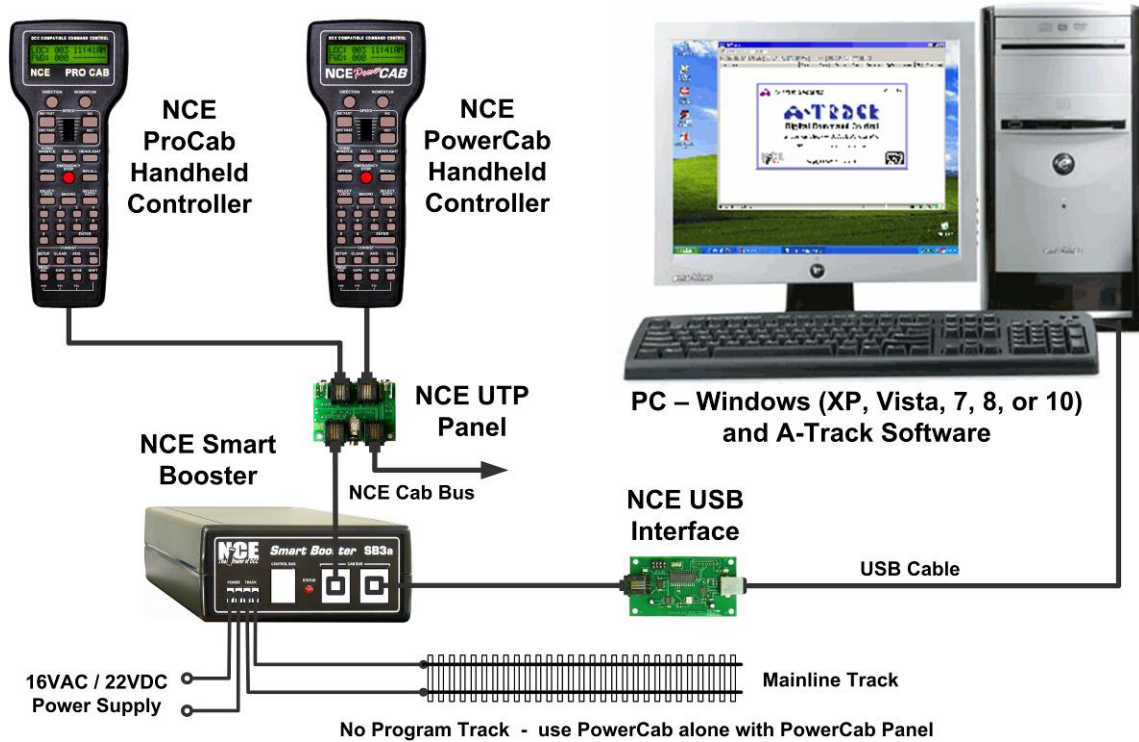

Alternatively, if you have an NCE Power Pro Command Station, you can simply connect A-Track to it via a standard Serial Port, if you have an older PC which is fitted with one, or via a USB Port and any readily-available USB-to-Serial (RS232) converter unit, as shown below –

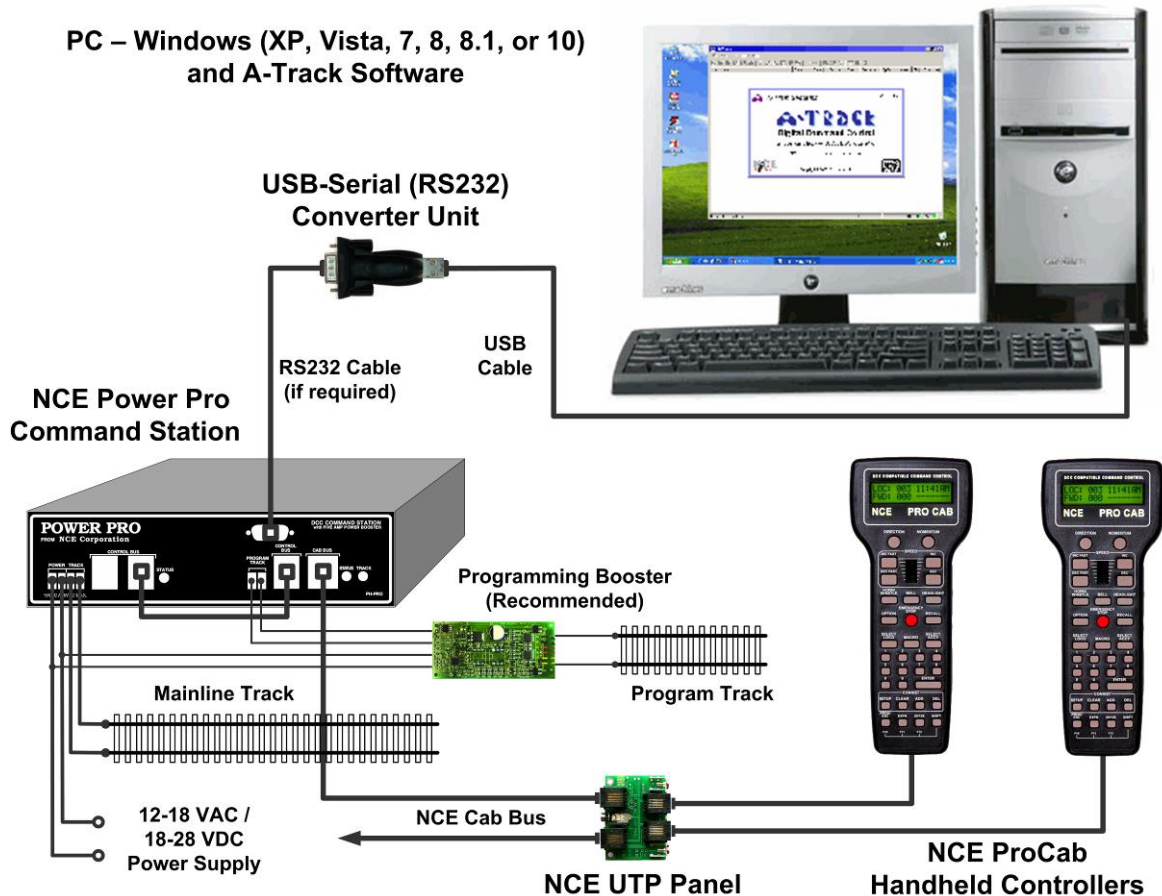

Note that the NCE Power Pro has limited Program Track drive capabilities so that, particularly where sound decoders are fitted to your locomotives, it is strongly recommended that a programming track booster unit (such as the SoundTraxx PTB-100 or the DCC Specialities PowerPax) is inserted between the Command Station and the Program Track. Once fitted the unit can be left permanently connected for programming and verifying all types of decoders. A programming track booster unit is not generally required when using an NCE Power Cab which has a comparatively higher drive capability in Program mode.

When used with either an NCE Power Pro, a Power Cab or Smart Booster Version 1.65 system, or a DCC Twin (all with a USB Interface Version 7), as well as looking after the contents of your DCC decoders, A-Track will also let you monitor, set up, save, and restore the complete status and operational parameters of the NCE Command Station and all attached Cabs from your PC. This frees you from the task of having to set everything up from scratch at the start of a session, and leaves you with more time to enjoy your model railroading. If you are using a DCC Twin, A-Track lets you perform these functions without requiring to you to purchase an NCE ProCab for this purpose. Note, however, that these set-up facilities are not available when A-Track is used with the earlier Version 1.28 of the NCE Power Cab and Smart Booster systems, or with a USB Interface Version 6.

1.2 Safeguard Your DCC Decoder Configurations

Using A-Track, you can read and save the status and parameters of each new locomotive decoder as delivered by the manufacturer. You will then be able to see the complete configuration details of the locomotive at a glance, on the PC screen, rather than only being able to check one parameter at a time by using a standard handheld Cab. A-Track can handle all types of decoders, including sound and accessory decoders, from all manufacturers who comply with National Model Railroad Association (NMRA) DCC standards. Currently, the system has been successfully tested with Bachmann, Broadway Limited (Paragon 2), DCC Concepts, Digitrax, ESU (LokSound), Hornby, Lenz, NCE, Model Rectifier, QSI (Quantum), SoundTraxx, Tam Valley Depot, Train Control Systems (TCS), Zimo, and ZTC decoders.

A-Track gives you total control over decoder programming and locomotive tuning. You can make changes to the decoder parameters directly, without having to compute or type in complicated numerical values, then immediately try out the effects, and decide whether to keep the alterations or go back to the original values.

Being able to keep back-up copies of each decoder's settings is especially valuable if you make an error in programming one or more parameters, and completely upset your careful tailoring of a locomotive's performance and characteristics. A-Track will allow you to retrieve the previous decoder set-up and restore the locomotive to the state it was in before your inadvertent mistake (as long as you remembered to save it, of course !).

Because A-Track lets you look at the decoder set-ups for several locomotives at the same time, and see the differences between them, it is relatively simple to tune the speed (and function) characteristics of these locomotives to run together in a consist. You can then run the locomotives individually, or together in the consist, on the track directly from the PC screen in order to check out the results, returning to the programming function if necessary to complete any fine tuning.

Whenever you purchase a new locomotive which is similar to one already in your roster, you can save a lot of programming time and effort by using A-Track to copy the decoder parameters from the configured locomotive to the new one – after making a back-up copy of the original settings in the new locomotive, of course (just in case !). Programming of the new locomotive is then reduced to giving it an appropriate description and a unique DCC address, together with any minor extra enhancements that you might want to make.

1.3 Gain Centralised Control of Your Layout

As well as handling locomotive decoders, A-Track also allows you to program and operate accessory (or stationary) decoders which are used primarily for the control of turnouts on your layout.

Additionally, if you have either an NCE Power Pro or a Version 1.65 Power Cab system with an NCE USB Interface Version 7, and wire up your turnouts to one or more NCE Auxiliary Input Units (AIUs) attached to your NCE system's Cab Bus, A-Track will be able to sense the actual position of each turnout and so verify that the intended route is set correctly before you run a locomotive into that section of the layout.

To make operation as simple as possible, A-Track gives you the facility to construct an on-screen graphical (or 'mimic') view of all your layout turnouts, such as that shown in the two example panels below –

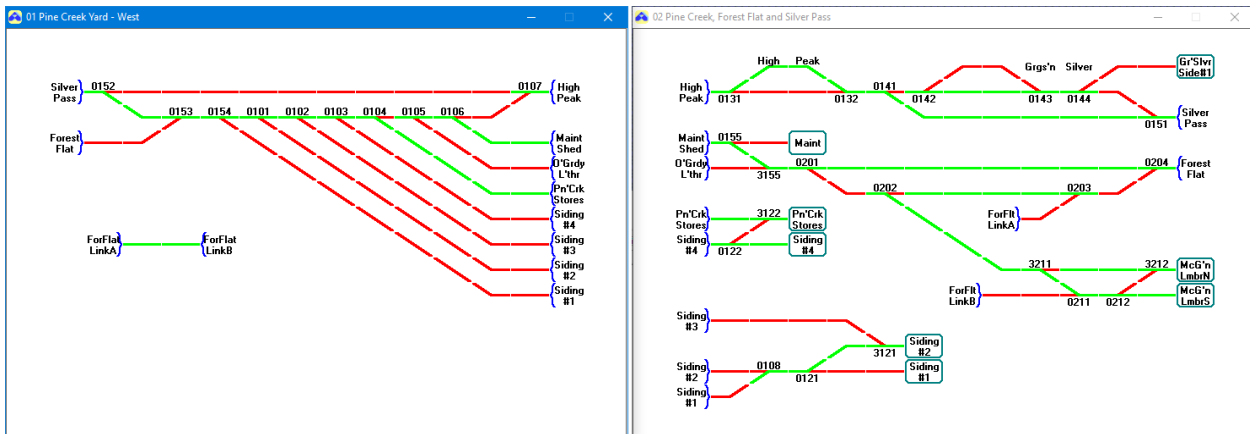

From these panels you can control the setting of any turnout via the click of a mouse, with the commanded position shown immediately on the screen display.

Rather than set each turnout individually for a specific route, A-Track gives you the choice of selecting the start and end points of a required route (plus an optional mid-point) and will then figure out the necessary intermediate turnout settings automatically. All turnouts can then be switched with a single click. The turnout settings for the found route can also be saved as an NCE System Macro – a set of turnout operating commands – for future use.

Both NCE Power Pro and all versions of Power Cab systems support the definition and use of Macros, and A-Track gives you the capability to expand the rather limited Macro facilities of the Power Cab systems to equal those of Power Pro systems.

1.4 Protect Your Decoders, Command Station & Handheld Cab Setups

With NCE Power Pro and Version 1.65 Power Cab systems with a Version 7 USB Interface, A-Track gives you full access to the Command Station, and hence the ability to display all of the key parameters stored in its internal memory on the PC screen. This allows you to perform Command Station and Handheld Cab setup directly from the computer, changing parameters to suit your immediate requirements, and to define and manipulate the composition of Consists and any stored Macros.

All parameters stored in the Command Station memory (System, Macros, Consists, and Cab Status) can be selectively saved (backed-up) to files on the PC's hard disk, or on CD-R / DVD-R or a USB flash drive (memory stick), and then recalled at any future time to restore the Command Station and its attached Cabs to a state corresponding to a previously-recorded operating session.

Similarly, A-Track allows all or part of the equipment roster to be saved to files, on any of the media listed above, simply for safe-keeping or for loading into another A-Track / NCE system elsewhere. Sets of CV values can be copied from one decoder to another, which can significantly reduce the time to program and set up a new locomotive added to your roster.

Given the current size of hard disks and the amount of RAM fitted in a modern personal computer, there is no practical limit to the number of different Command Station or Cab setups which can be saved to, or restored from, the computer's permanent or removable storage, and A-Track can handle equipment roster lists stretching to hundreds (or even thousands) of equipment items. However, such large

lists tend to be unwieldy to view and manipulate, so it is usually easier to compile shorter rosters – corresponding, for example, to an operating session – using the facilities available in A-Track.

1.5 Additional Facilities

As well as its primary purpose of storing and manipulating the contents of DCC decoders, A-Track also allows you to control any selected locomotive or set of turnouts on the Main Track directly from the PC, using the mouse and a 'soft' on-screen controller, by issuing DCC commands directly to the NCE Command Station. Although this control function is really intended as a test facility, to check the results of programming a locomotive decoder, for example, you can call up and operate as many as eight 'soft' controllers on the screen simultaneously - if you think you possess the capability and dexterity to run eight locomotives simultaneously on the layout by yourself !

1.6 Obtaining Your Copy of A-Track

A-Track may be downloaded from the A-Train Systems website at –

<http://www.a-train-systems.co.uk/getatrack.htm>

- completely free of charge for your personal or club use. Support to resolve any problems which you may encounter in using A-Track is also available free through the website (see **Section 11.2**).

You can choose to download A-Track either as a simple executable **Setup File** together with the **Reference Manual** and/or **User Guide** and **Installation Notes**, or as a complete **Installation Package** (including Adobe Reader).

Click on the selected file to download, then select **Save** (not Run) to copy the file to a folder on your computer. In Windows XP the default location will be My Documents, or Downloads in Windows Vista, Windows 7, Windows 8, or Windows 10, although you can choose any other folder as a destination if you wish – but take note of where the file is saved so that you can locate it later for installation.

Once installed (see **Sections 3.1** through **3.4**), you have the option of registering your copy of A-Track, also without any charge, as described in **Section 11.1**. Registered users will have priority with regard to support and assistance in rectifying any problems which they come across.

If, after using A-Track, you think that it is of benefit to your model railroading activities, and would like to support future A-Track development and enhancements, then you are welcome to make a voluntary donation - but you will not be 'nagged' or pressured to do so.

Donations can be made safely and securely via [PayPal](#), using any credit or debit card, even if you do not have a PayPal account of your own

Very Important : Please note that the term "completely free of charge" must not be confused with "free for you to exploit as you wish". A-Track is copyrighted software, and not a public domain product. You may not distribute or sell A-Track either alone or as part of any commercial item, as set out in detail in the terms of the A-Track licence in **Chapter 16**.

2 SYSTEM REQUIREMENTS

2.1 Personal Computer

- Pentium 3 processor or better, running at 500 MHz or faster
- At least 512 MByte RAM to get the best performance from the Windows Operating System (2 GByte recommended for Windows 7 and above) – A-Track itself requires minimal memory
- At least 50 MByte of hard disk space available for installation
- Minimum screen resolution of 800 x 600 pixels (1024 x 768 preferred) showing at least 256 colours (8-bit colour setting) or better
- One available RS232 Serial port or USB 2.0 port
- CD-R drive (if installing the software from a distribution CD)
- Printer (optional)

It is assumed in this Reference Manual that the reader is familiar with the basic operation of a Personal Computer using a Windows operating system, including the use of mouse and keyboard, and is able to find his or her way through file and folder structures to store and retrieve any required files or other data.

In this Reference Manual, 'click' means a left-click of the mouse, ie. press and immediately release the left mouse button. 'Right-click' means the same action applied to the right mouse button, and 'double-click' means two left-clicks performed in rapid succession.

As far as possible, A-Track uses only common Windows operations to manipulate the data involved in handling DCC decoders and the NCE Command Station and Handheld Cabs. Hence, if anything in the descriptions is not clear, you should be able to find further information and more detailed explanations in any of the multitude of introductory personal computer and Windows books available on the market.

Most of the illustrations in this Reference Manual have been captured from the screen of a machine operating under Windows 10. Where operations are significantly different under Windows XP, Vista, Windows 7, 8, or 8.1 screen shots from one of these operating systems are shown as well, or an explanatory note is at least included in the text.

2.2 Operating System

A-Track can be installed under, and will operate with, any of the following Windows operating systems –

- Microsoft Windows XP (Service Pack 2 or later)
(Home, Media, or Professional Edition)
- Microsoft Windows Vista (Service Pack 1 or later)
(Home Basic, Home Premium, Business, or Ultimate Edition)
- Microsoft Windows 7
(Starter, Home Premium, Professional, or Ultimate Edition)
- Microsoft Windows 8 and 8.1

(Standard, Professional, or Enterprise Edition)

- but note that A-Track cannot be run under Windows 8 RT, as installed on tablet machines (now discontinued by Microsoft), since this version does not support desktop applications

- throughout the Reference Manual, any reference to operation under Windows 8 applies equally to Windows 8.1

- Microsoft Windows 10
(Home, Professional, Enterprise, or Education Edition)

2.3 DCC Command Station



A-Track will operate in conjunction with any of the following items of NCE equipment –

- NCE Power Cab (Versions 1.28 or 1.65)
- NCE Smart Booster (SB3, SB3a or SB5)
- NCE DCC Twin
- NCE Power Pro 5-Amp System (PH Pro or PH Pro R)
- NCE Power Pro 10-Amp System (PH-10 or PH-10 R)
(NCE CS02 Command Station plus PB110 Power Booster)

Again, it is assumed in this Reference Manual that the reader is familiar with the functionality provided by the NCE Power Cab, Smart Booster, or Power Pro Command Station and any associated Handheld Controllers (Cabs), so that the standard details of their operation are not covered in this Reference Manual.

Please refer to the NCE Power Cab or Power Pro System Reference Manuals, and other available NCE documentation, for full specifications and operating instructions.

3 GETTING STARTED

To help you locate the information you need from this large Reference Manual, if you use the electronic version (the **.pdf** file) in Adobe Reader, for example, you will find that all chapter and section headings are hyperlinked, so that you can jump to any part of the document from the Contents listing, shown by clicking on the Bookmark icon ( or ), or via the Adobe Reader **View** menu by going to **Navigation Panels / Bookmarks** (or **Show/Hide / Navigation Panes / Bookmarks** in later versions).

In addition, you can also click on any reference in the text to another section of the Reference Manual, which will take you straight to that section. Click on the **Back** or **Previous View** button to return to where you started. If these buttons are not shown, search for the relevant set of Toolbar buttons from the Adobe Reader **View** menu. As an example, click on the reference to **Chapter 13** here (the number), or in the next paragraph, to find out about installing USB-to-Serial devices.

Note that, if you are planning to use a USB-to-Serial Converter or the NCE USB Interface unit to connect your PC to the NCE equipment, the associated driver software can be installed either before or after installation of the A-Track program, although both have to be correctly installed before the full functionality of A-Track will be available. Some guidance on the installation of the various varieties of driver software can be found in **Chapter 13**, near the end of this Reference Manual.

Before starting installation of A-Track from the Full Installation Package, from a Distribution CD, or directly from the Setup File, ensure that no other applications are running on the PC, and that the active User has administrative rights (this is the normal status when the operating system is either Windows XP Home or Media Edition, in Windows Vista or Windows 7 Starter or Home Editions, in Windows 8 Standard Edition, and Windows 10 Home Edition, but you may need to log on as an Administrator when using Windows XP Professional Edition, Windows Vista and Windows 7 Business, Professional, or Ultimate Editions, or Windows 8 or 10 Professional, Enterprise or Education Editions).

Once all of the necessary driver and program software is installed, A-Track can be run by any User - no aspect of A-Track operation requires administrator privileges.

3.1 Installation from the Full Installation Package

Having downloaded the Installation Package from the A-Train Systems website (see **Section 1.6**), 'unzip' the compressed file (**A-Track4_Install.zip**) to a convenient folder by right-clicking on the file, and then on the **Extract All** option on the pop-up menu (if you do not have a dedicated file-compression program such as WinZip installed on your computer).

The installer program (**A-Track4_Install.exe**) can be run directly from the folder into which you 'unzipped' the Package by double-clicking on it. Alternatively, you can copy the complete set of unzipped files and folders to a USB flash drive (memory stick), or write them to a CD-R disk, if you wish to install A-Track on another computer (such as one without Internet access) – ensuring that you preserve the unzipped folder structure. Once copied to a CD-R, the A-Track installer should run automatically when loaded into a suitable CD-DVD drive, as described below for installation from the Distribution CD.

If you have copied the Installation Package to a USB flash drive then, after plugging the device into an available USB port, it is unlikely that the installer will run automatically. Hence, click on **My Computer** in XP, **Computer** in Vista, Windows 7 or 8, or **This PC** in Windows 8.1 or 10, and locate the USB drive (usually **D:** or **E:**). In Windows 8 or 10 you will first need to open File Explorer on the Desktop in order to locate the USB drive in **Computer** or **This PC**. Double-click on the drive icon to reveal the list of files and folders, then double-click on the file named **A-Track4_Install.exe**.

When the A-Track installation window opens, and presents you with a set of simple options, follow the instructions given below for Installation from the Distribution CD.

3.2 Installation from the Distribution CD

Insert the distribution CD into your DVD / CD drive, ensuring that no other applications are running on the PC.

Although the installation program will normally run immediately under Windows XP, in the case of either Windows Vista, Windows 7, Windows 8 (8.1), or Windows 10 the standard operating system in-built security measures will first display an AutoPlay window to confirm that you wish to run the program –

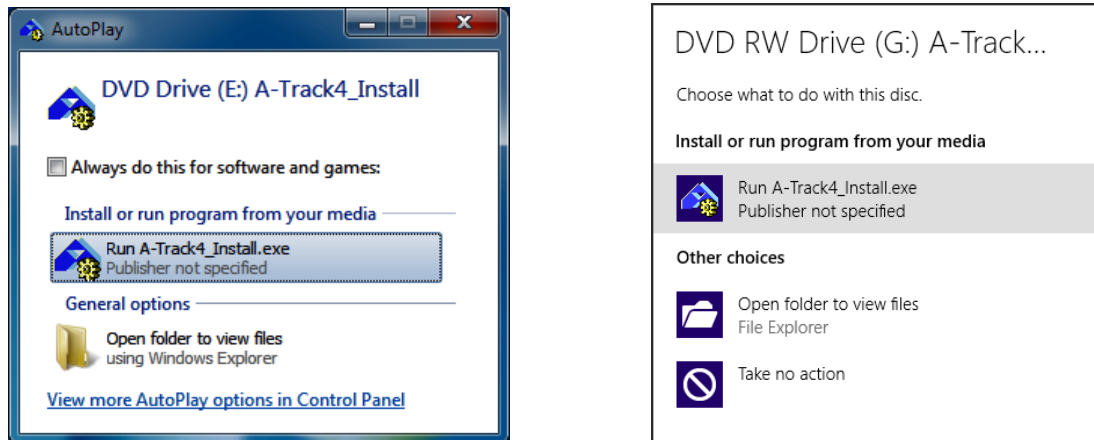

Click **Run A-Track4_Install.exe** to continue, and then click **Yes** on the following security prompt, similar to one of those shown below, to allow the A-Track installation to proceed –

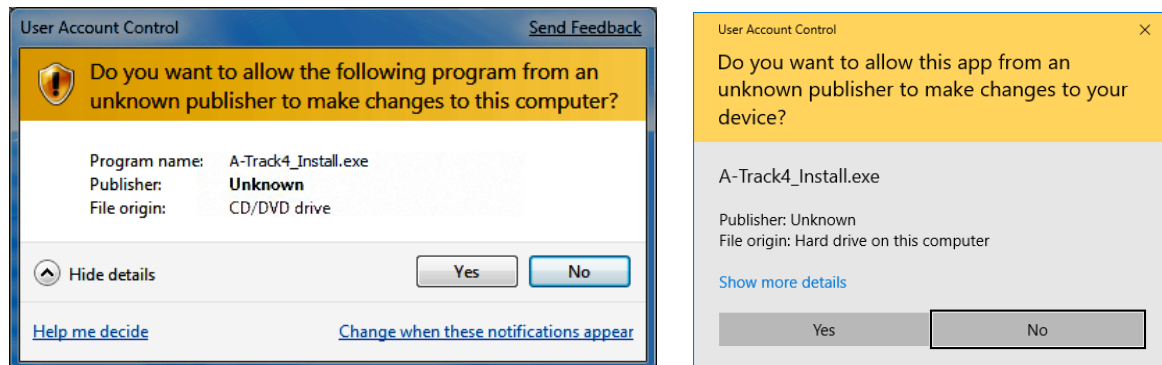

If, for any reason, the Autorun (or AutoPlay) facility has been disabled on the PC, and the CD-R fails to run automatically, click on **My Computer**, **Computer**, or **This PC**,

depending on your version of Windows, and locate the DVD / CD drive (usually **D:** or **E:**). In Windows 8 or 8.1 you will first need to open File Explorer on the Desktop in order to locate the DVD / CD drive in **Computer** or **This PC**. Double-click on the drive icon to reveal the list of files and folders, then double-click on the file named **A-Track4_Install.exe**.

The A-Track installation window opens and presents you with a set of simple options –



Installation Guidance – View Notes opens a copy of these instructions in webpage format (**.htm**), and displays them in the browser program installed on your computer. If no browser is found, then Windows will display an error message.

Install A-Track Program – Install will close the installation window and then run the A-Track SetUp process, as described for installation from the Setup File in **Section 3.4** below. However, note that, if you have a previous version of A-Track installed on the PC, then it is recommended that you uninstall it before proceeding to install the latest version - most easily done by using the **Uninstall A-Track** option from the Start Menu or Start Screen (also described in **Section 3.4** below).

View User Guides – Open Folder will open a folder containing the A-Track User Guide, Installation Guides, and Reference Manual in Portable Document Format (**.pdf**) which can be read using the Adobe Reader program

Install Adobe Reader will install a copy of this free program (Version 11.0.8) if you do not already have a suitable version installed on your computer – just follow the prompts to complete the straightforward set-up.

Close removes the A-Track installation window from the screen – you can open it again by re-inserting a copy of the Installation Package on CD-R into a DVD / CD drive, by plugging a copy on a USB drive into a USB socket, or by locating and double-clicking on the **A-Track4_Install.exe** file from wherever you stored it.

3.3 Installation from the Setup File

If you have chosen to download the simple Setup File (**A-Track44-194-SetUp.exe** or a later version) from the A-Train Systems website (see **Section 1.6**) then locate the file in the folder into which you downloaded it. With Windows 8 you will need to do this from the Desktop, accessed by clicking the appropriate tile on the Start Screen, and then opening File Explorer.

If you have a previous version of A-Track installed on the PC, then it is recommended that you uninstall it before proceeding to install the latest version. The easiest way to do this is to use the **Uninstall A-Track** option from the Start Menu, as shown at the end of **Section 3.4**.

Alternatively, you can open Control Panel and select Add or Remove Programs in Windows XP, or Uninstall a Program in Windows Vista, Windows 7, 8, or 10 (access Programs and Features). Wait for the list of installed programs to be displayed then click on the entry for A-Track, and finally click on the Remove button in Windows XP, or the Uninstall button in Windows Vista, Windows 7, 8, or 10. Once the A-Track program is uninstalled, close the open Control Panel window.

Before running the Setup File (by double-clicking on it) ensure that no other applications are running on the PC. Although the Setup File will normally run immediately under Windows XP, in the case of either Windows Vista, Windows 7, 8, or 10, the standard operating system in-built security measures, as described in the preceding section on installation from the distribution CD, will prompt you to allow the file to run – click **Yes** to continue. You may also receive some cautionary messages from any anti-virus or Internet security software which is installed on your machine.

3.4 Installing A-Track Step-by-Step

If installing from the Installation Package, click on **Install Program**, or otherwise locate and double-click on the SetUp File (**A-Track44-194-SetUp.exe** or a later version) in the appropriate folder to start the installation.

The default security settings in Windows Vista, Windows 7, 8, or 10 (but not under Windows XP) will then display a couple of warnings, requiring you to allow the set-up program to run –

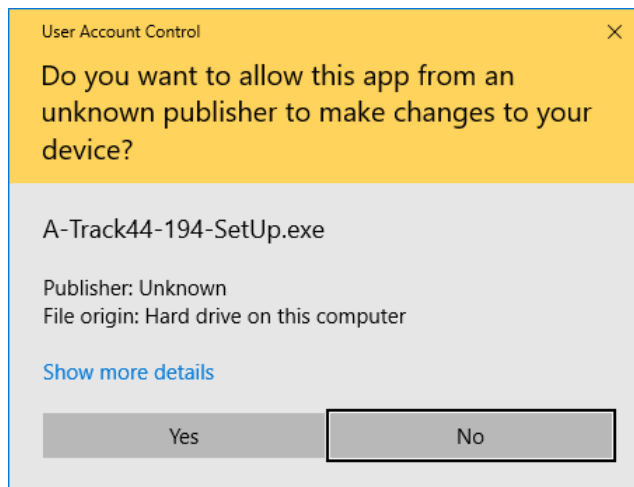

– and you may also receive some cautionary messages from any anti-virus or Internet security software which is installed on your machine – before the A-Track SetUp Welcome screen shown below is displayed. Again, as noted in the SetUp window, it is recommended that any other open programs or windows are closed before proceeding further.

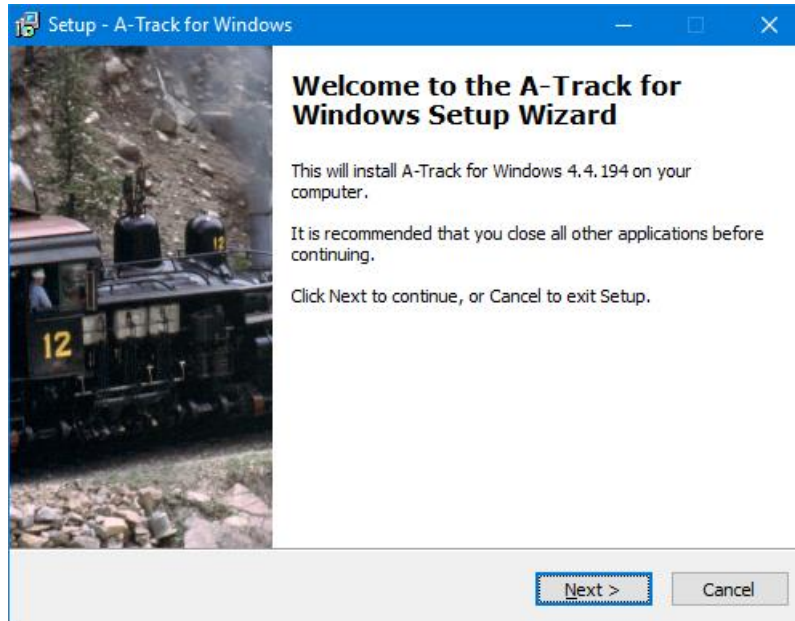

Click on **Next** to continue with the installation (or **Cancel** to quit SetUp) and to display the end-user licence screen. Here the full text of the licence, under which the A-Track software is provided, is available if you wish to read it (printed in full in **Chapter 16** of this Reference Manual).

You must accept the terms of the licence, by clicking on '**I accept the agreement**', in order to display the **Next** button and to be able to continue with A-Track installation –

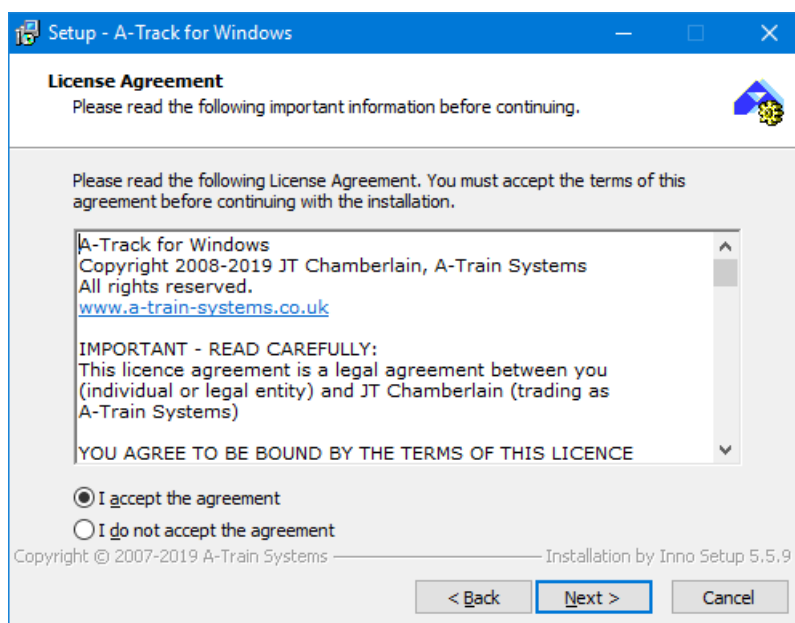

Click **Next** to display the default destination folder for A-Track. Unless you have very good reasons to change the install destination (and understand the possible complications of doing so) it is recommended that you leave it as shown at **C:\Program Files (x86)\A-Track** (or **C:\Program Files\A-Track**) -

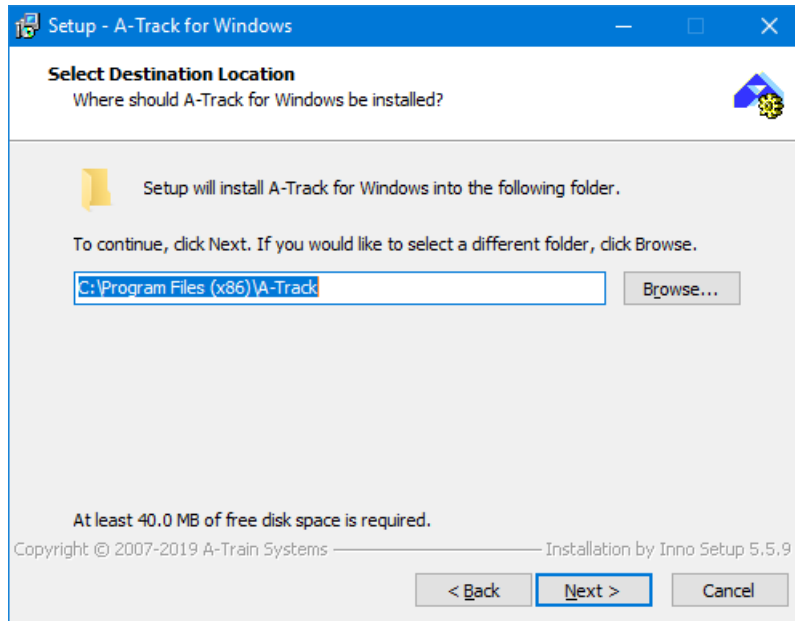

Click on **Next** to continue. The set-up program will now ask you to confirm that it should proceed to create a set of entries for A-Track on the computer's Start Menu. These will be complemented by the placement of an A-Track icon on the Desktop. As in previous windows, you are also offered the options of returning to change your previous selection (**Back**), or of abandoning the A-Track SetUp (**Cancel**) -

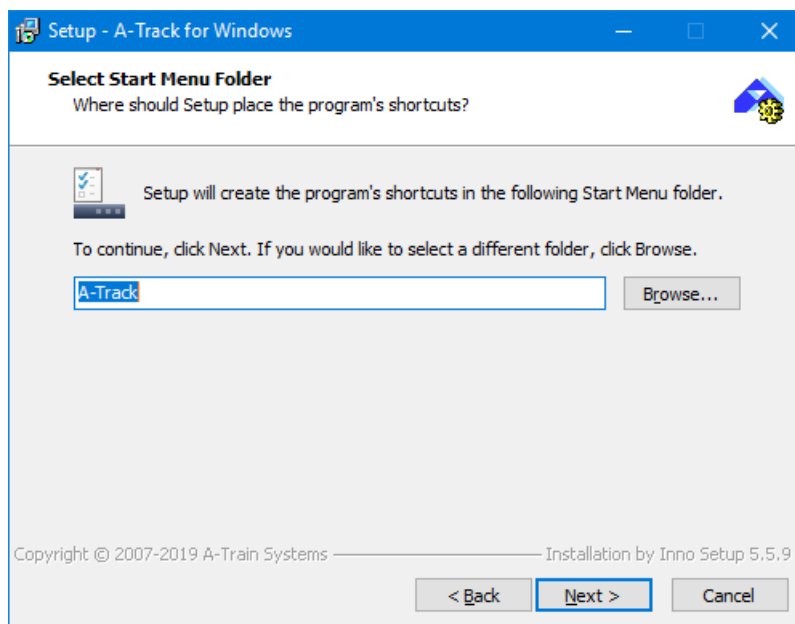

Accepting the default option gives A-Track its own entry on the Start Menu, but you can choose to place the A-Track entry within an existing Start Menu folder (such as Accessories) by using the **Browse** button.

When you are happy, click **Next** to continue –

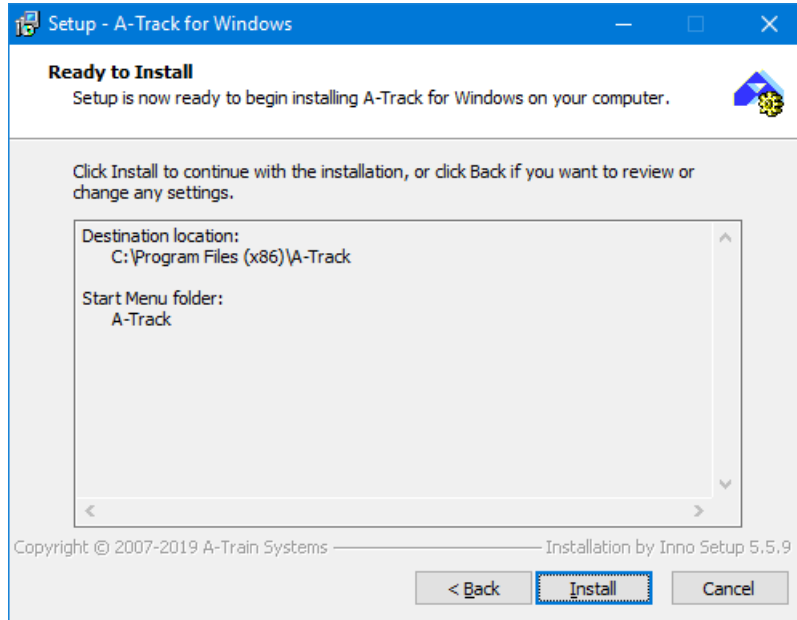

On the confirmation screen, if you are satisfied with the installation settings, click **Install**. Setup will then proceed to install all of the files required to support A-Track, together with the A-Track executable program itself. If any of the Windows support files are already installed in the PC then SetUp will only install a replacement version if it is more up-to-date than the existing file -

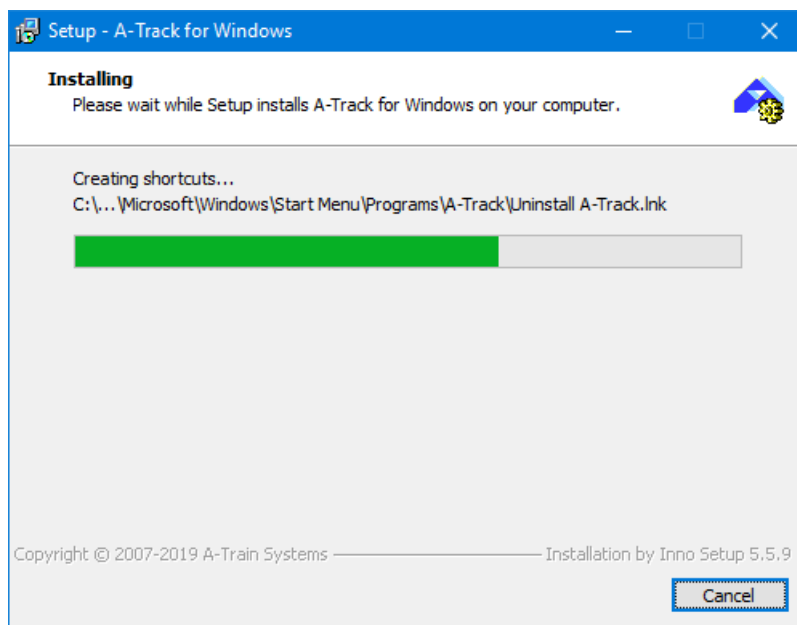

Installed files are linked into the Windows Registry as required –

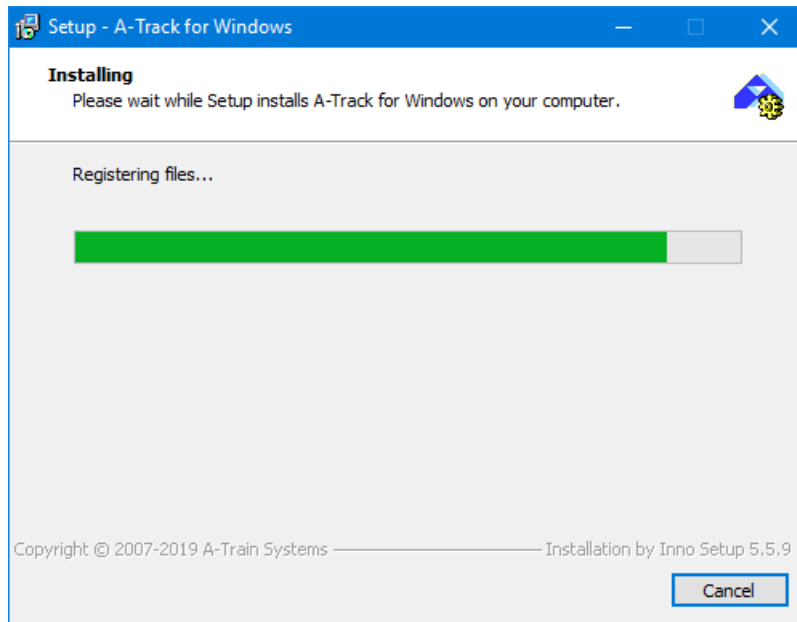

- and then a final window is displayed to show that the A-Track installation is complete -

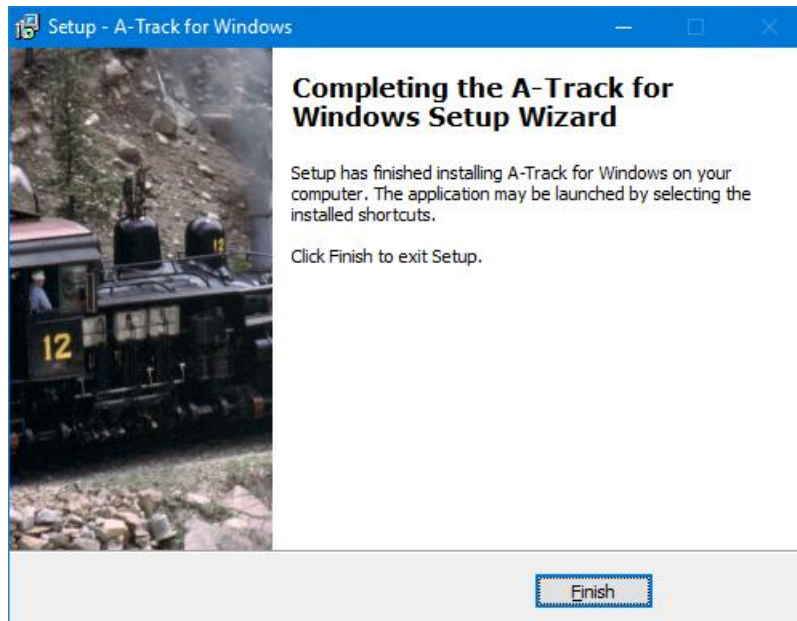

Click **Finish** to close A-Track SetUp and return to the Desktop.

To launch A-Track double-click on the program icon (🚂) on the Desktop. In Windows 8 (and in Windows 10) a corresponding tile (🚂) is placed on the Start Screen.

In Windows versions other than Windows 8, you can also launch A-Track from the Start Menu by clicking on **Start**, then **Programs** (or **All Programs**, depending on

your selected Start Menu format). Locate and move the mouse to the A-Track folder, and then click on the **A-Track** program as shown in both the Windows XP screen-shot below, which also shows the A-Track Desktop icon, and that from Windows 10 on the right –

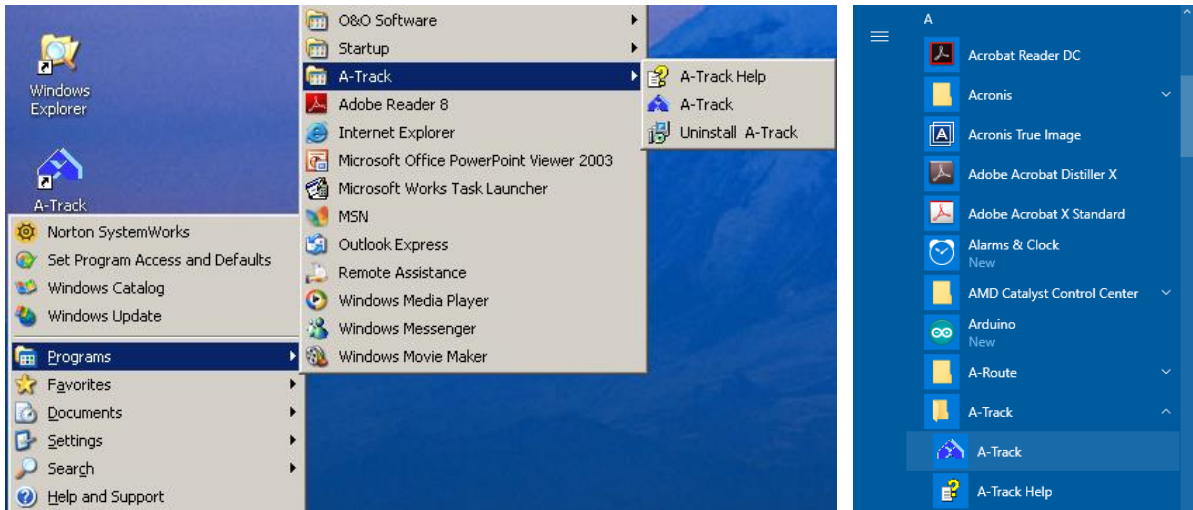

Note that, as well as an entry for the executable program, **A-Track**, the A-Track Start Menu folder also contains a link to the **A-Track Help** file. This file contains the full text of the A-Track Reference Manual (this document) and, as will be described later, can be accessed from anywhere within the A-Track program while it is running by using the normal **Help** menu, or by pressing the **F1 key** at any time.

The third entry within the A-Track Start Menu folder is **Uninstall A-Track** which will launch an Uninstall utility to completely remove A-Track from your computer. This is a quicker route to program removal than going through the Windows Control Panel.

However, (for reasons known only to Microsoft) this option is not displayed directly on the Windows 8 Start Screen, but can be accessed by a *right-click* on the A-Track tile –

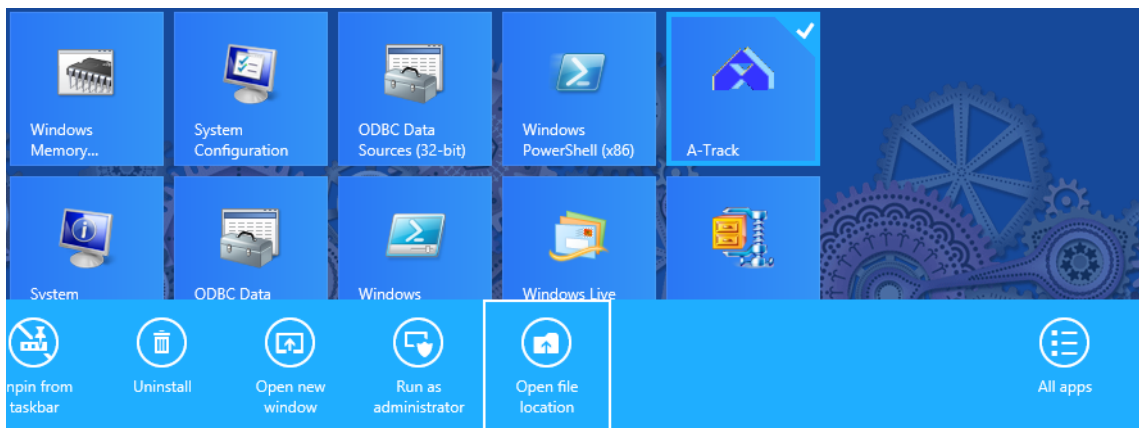

If an **A-Track** tile does not appear on the Start Screen, you can access the program by a *right-click* on a blank area of the Start Screen, then on the '**All apps**' option (or in

Windows 8.1 click the **All Apps** (↓) button on the Start Screen), and then locating the **A-Track** group of tiles.

While you can click on 'Uninstall' and go through the normal Control Panel process, it is quicker to click instead on the '**Open file location**' option and then double-click on the **Uninstall A-Track** option shown when the File Explorer window opens –

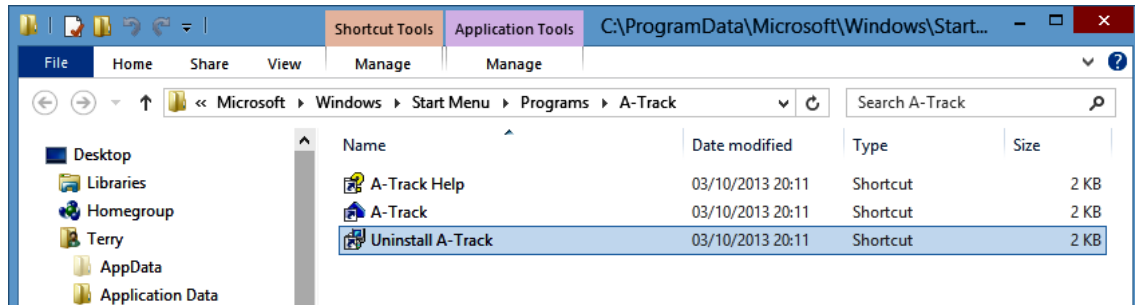

This window also gives you access to the **A-Track Help** file, although alternatively this can be reached from the Start Screen by a *right-click* on a blank area of the Start Screen, then on the '**All apps**' option (or, in Windows 8.1, click the **All Apps** (↓) button on the Start Screen), and then locating **A-Track Help** in the appropriate group of tiles –

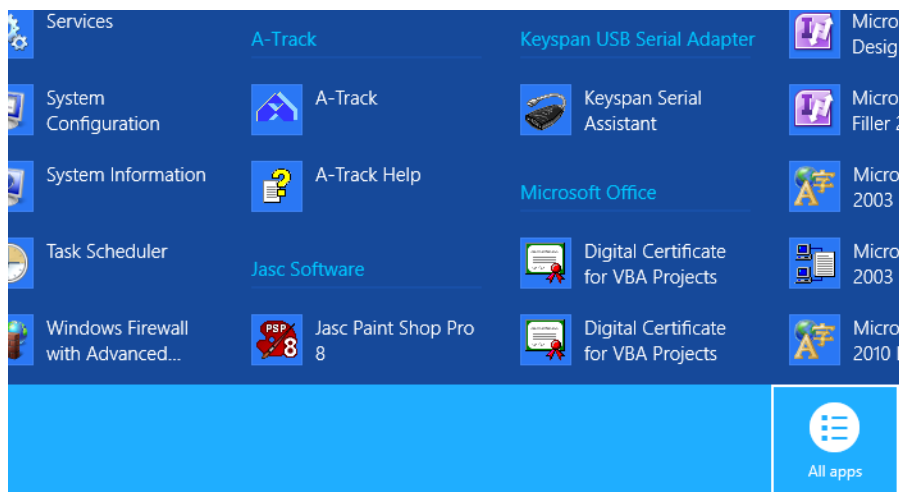

Returning to Uninstall, note that, when using Windows Vista, Windows 7, Windows 8, or Windows 10 their default security settings will display one or two warnings, requiring you to allow the uninstall program to run.

The Uninstall process then starts (except in Windows XP) with two requests for confirmation –

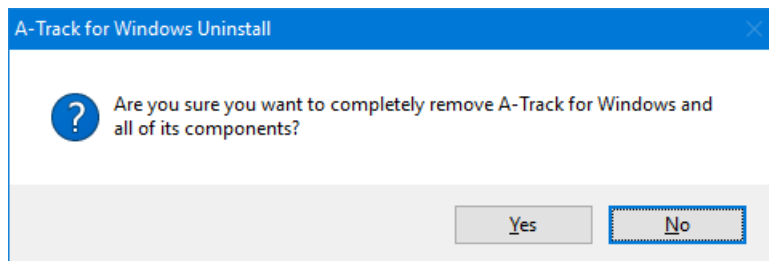
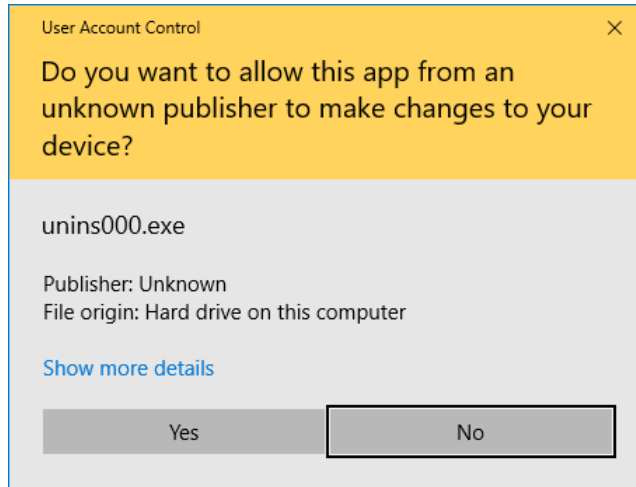

Click **Yes** in each instance to continue (or **No** to abandon the uninstall process).

During the uninstall process in Windows XP you may be presented with a set of windows inviting you to remove shared files which were installed with A-Track, and which are not believed to be used by any other installed program. For example –

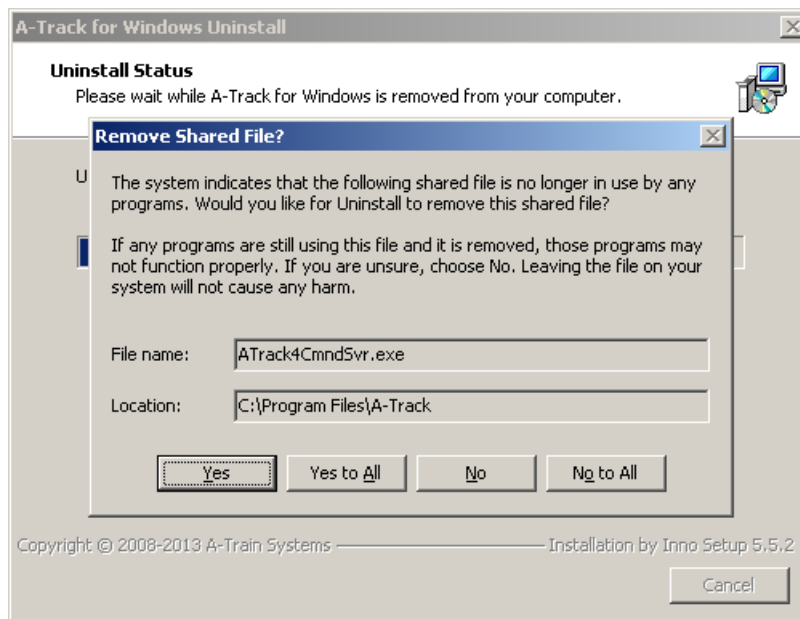

Leaving these files in place will not cause any harm, nor slow down the performance of your computer, and is the ultra-safe approach, but you can choose to uninstall them if you wish, by clicking on the appropriate button shown above.

The A-Track program itself is then uninstalled –

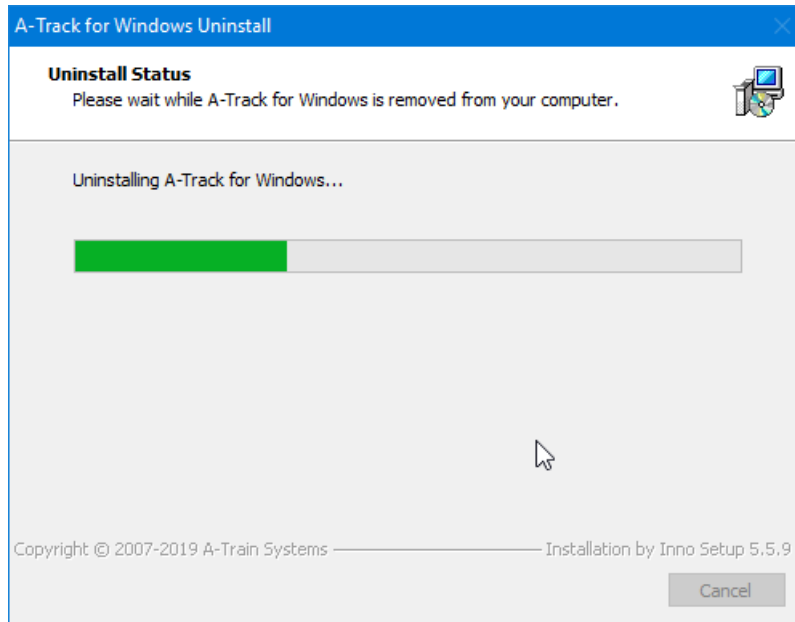

– followed by a final confirmation window –

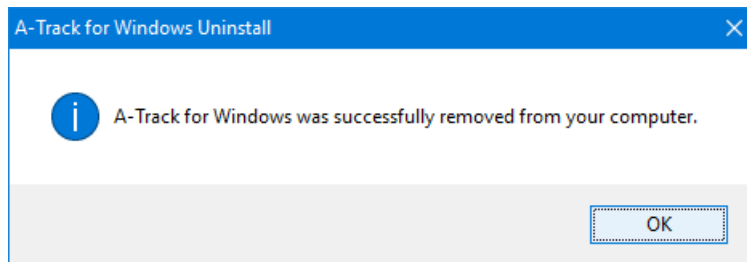

Click **OK** to complete the uninstall process.

In some circumstances you may see a different confirmation window –

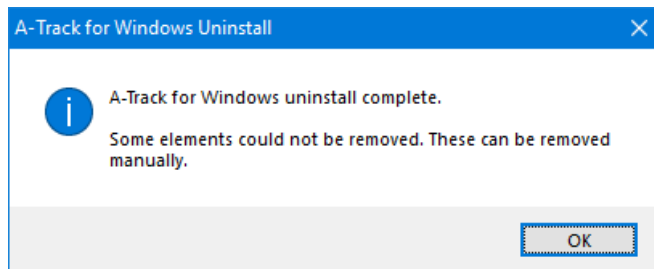

Generally this will occur when changes have been made to the installation folders or their contents following installation (not to be recommended at any time), or you have

saved some of your own files to an installation folder (again not really recommended), and the A-Track uninstaller is unable to remove one or more installation folders because they contain a file which is currently open.

After clicking **OK** in such cases, you can either leave the remaining files or folders in place, since they will not generally have any adverse effects on your computer's operation, or you can open the **A-Track** installation folder in **C:\Program Files** (or **C:\Program Files (x86)**) and manually delete, or move, the offending files or folders.

One situation where this can arise is where, for some reason, A-Track has not shut down correctly and the A-Track Command Server file is still running in the background. You can either open Task Manager, locate the file (A-Track4-4 DCC Command Server) in the list of background processes, and click the **End task** button, which will then allow you to delete the file and the installation folder, or you can simply close all of your other programs and restart the computer.

Note that, in all cases, uninstalling A-Track will still leave a small set of A-Track custom settings within the Registry. These settings are stored automatically during your normal use of A-Track and reflect your preferences regarding window formats and views, together with lists of the most-recently used files and any selected options. If you then reinstall A-Track at a later time, your preferred settings will be re-applied to configure A-Track. The custom settings occupy a very small proportion of the Registry and will not have any discernable effect on the performance of your computer or other applications.

Warning : unless you know *exactly* what you are doing, do **not** attempt to edit or delete any item within the Registry, since any change made incorrectly can have disastrous consequences (there is **no** Undo facility), and may crash your computer completely or render it unable to run properly in future.

3.5 Starting the Program

Start A-Track from the Start Menu, as shown in **Section 3.4**, or by double-clicking the A-Track icon (🚂) on the Desktop, or in Windows 8 by clicking the A-Track tile (🚂) on the Start Screen.

A-Track displays a start-up window in front of its main window, and then checks to see if an NCE Power Cab, Smart Booster, or Power Pro Command Station is connected to one of the PC's Serial or USB ports (and powered-on). If no connection is detected, then you will see the window contents as displayed below –

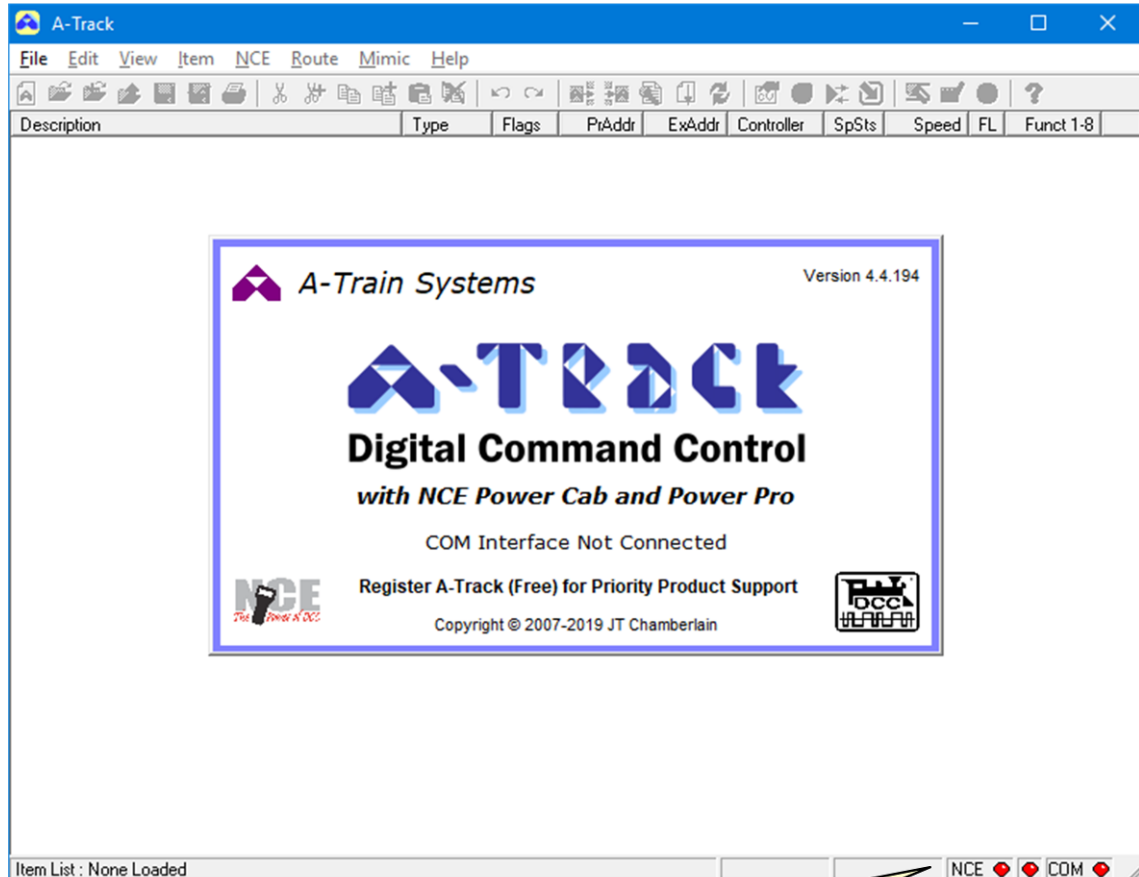

Connection Status for NCE Command Station and Serial / USB Interface (neither connected at this time)

The three indicators on the status bar (in the bottom righthand corner of the main A-Track window) are **red** to show that no NCE hardware unit is currently connected or operational.

Connecting an NCE Power Pro Command Station by plugging a suitable RS232 Serial cable or USB-to-Serial converter into the 9-pin Serial Port socket on the front panel of the Command Station, and the other end of the serial or USB cable into the appropriate PC port, will cause both the left- and rightmost indicators to turn **green** whenever the Command Station is switched on.

If a connection to the NCE Power Pro Command Station exists when A-Track is started, the program transfers the data representing the status of all Consists (sets of locomotives to be controlled as a single unit), as currently held in the Command Station, to the memory of the PC. Retrieval of the data block takes less than 10 seconds to complete, with progress displayed on the screen, as shown below. During the transfer period, you should not operate any of the NCE Handheld Controllers (Cabs) since there is a small risk that communications between A-Track and the Command Station can be disrupted.

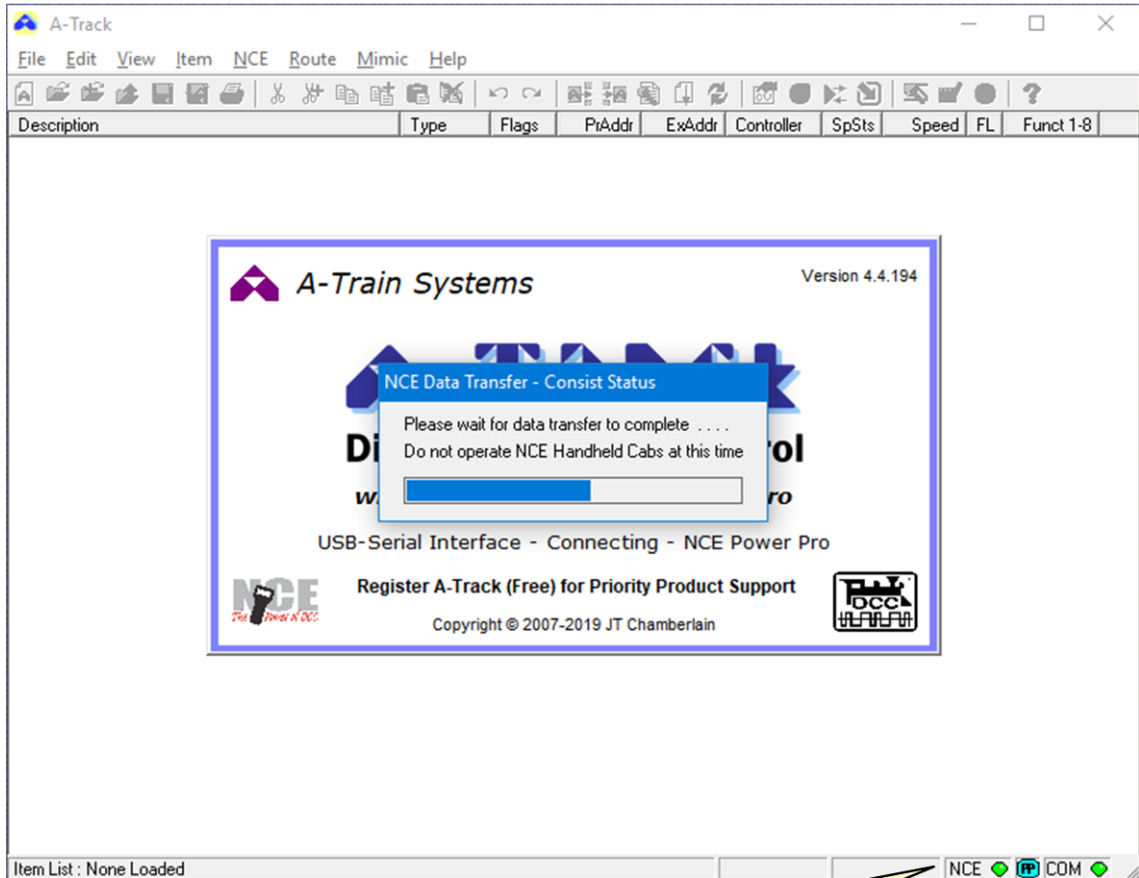

Connected to NCE Power Pro Command Station and USB / Serial Interface

If you hover your mouse cursor over the status bar panels containing the NCE and COM indicators, pop-up labels will appear displaying, respectively, the Command Station Software Version, and which of your computer's COM ports is currently being used by A-Track to connect to the Command Station, together with the bit (baud) rate at which the serial link is operating, as shown below -



You will also notice the display of a banner in the lower part of the start-up window inviting you to register (free) for full, priority support of A-Track. Registration is purely voluntary, and A-Track is fully functional in all respects after installation.

If you do choose to register your copy of A-Track, by following the simple steps described in **Chapter 11**, then, whenever you subsequently start A-Track, your name will be displayed in the start-up window instead of the registration invitation.

You may install and operate A-Track on as many computers as you like, but note that each installed copy of the application will have a different serial number. Although this means that each installation has to be registered separately (if you wish to do so), the online registration process via the A-Train Systems website, as described in **Section 11.1** is fully automated, and so does not require a great deal of time nor effort.

If an NCE Power Pro Command Station is not connected until after A-Track has completed its initialisation, loading of the Consist data block is postponed until the Command Station is plugged in, and powered on. Loading will then proceed as before (although it may take up to 10 seconds before the data transfer starts), with display of the progress bar in the centre of the A-Track window. Allow the data transfer to complete without interruption.

The third, middle indicator on the status bar, which is initially **red**, then replaced with an icon indicating the type of connection established (**PP** here), is used to show the progress of A-Track in acquiring the status of all NCE Handheld Cabs connected to the NCE Power Pro Command Station. After retrieval of the Consist data, the lefthand panel of the status bar will turn **red** and will show which Cab details are being accessed, firstly whether a particular Cab is connected and then loading the data for each active Cab, as shown in the examples below –

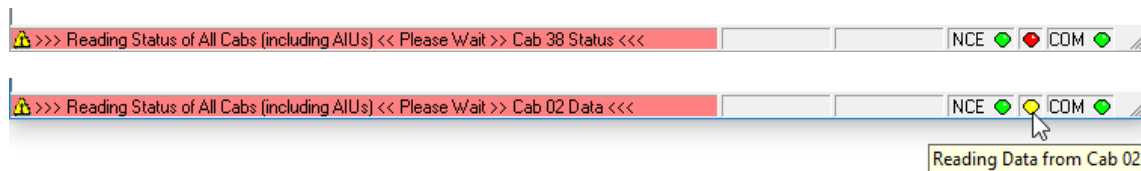

During this process, the middle indicator on the status bar will alternate between **red** and **yellow** while the status of all Cabs is being read, then between **yellow**, and **green** while the full data from all connected Cabs is retrieved. If any Auxiliary Input Units (AIUs) are connected to the NCE Cab Bus, the middle indicator will briefly flash **blue** while the state of their inputs is being loaded. Hovering your mouse cursor over the middle indicator will also display a pop-up label showing the current operation in progress, as can be seen above. After the full scan is completed, the middle indicator returns to the icon representing the type of connected Command Station (**PP** here).

The time taken to complete this full scan is 2 to 3 seconds per connected Cab if connected to an NCE Power Pro, or about 5 to 7 seconds per Cab when using an NCE Power Cab Version 1.65 system. Including setup time, and because the complete status for Cab Address 02 is always transferred to A-Track, whether or not a Cab with this address is actually connected, the minimum total scan period is about 15 seconds.

Thereafter, A-Track will monitor the status of the Locomotive allocated to each connected NCE Cab, and currently under control (but not those in the Cab Recall List), reading the status of each Cab in turn at 2-second intervals, together with the status of any connected AIUs (and hence the position of all connected layout turnouts). A-Track also checks that the NCE Command Station remains connected (and powered on) every 10 seconds. If you are using a USB-to-Serial converter which is fitted with one or more LED indicators, then you may see the indicators flash to show the transfer of the relevant commands and responses.

While a Command Station is connected, you can update the displayed Cab allocation and full Cab status at any time by clicking the **Refresh** (🔄) icon on the A-Track toolbar (See **Sections 4.1, 9.4, and 12.3**) or by clicking on **View** on the A-Track menu bar, followed by **Refresh Item Allocation & Status**. When you use the View menu option, you will be asked whether you wish a periodic scan (every 6 minutes) of attached NCE Cabs to be performed automatically –

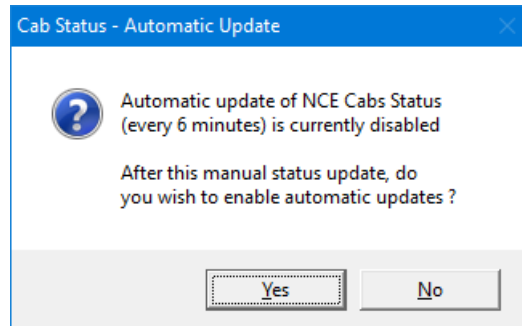

Click **Yes** to enable future automatic scans of NCE Cab status, or **No** to leave further scans disabled (a scan will be performed this time). Leaving scans disabled is preferred if you are actively using A-Track, particularly if you are intending to adjust the setup of the NCE Command Station or Cabs, or to change Consist or Macro settings, without being interrupted periodically (all editing is disabled during a Cab status scan). Further details of the way in which the NCE System Status data is handled can be found in **Chapter 9**.

A **tick** mark next to the **Refresh Item Allocation & Status** option on the View menu will be displayed to indicate that periodic scans of attached NCE Cabs are enabled. In this state, every 6 minutes, A-Track will automatically re-scan the status of the NCE Cabs attached to the Command Station. The current Cab allocation and status will be cleared from the **Item List** (described in the following **Section 3.7** and in detail in **Chapter 4**), the lefthand panel of the status bar will turn red and will show the scan details, and the middle indicator on the status bar will sequentially show **red, yellow** and **green**, returning to the appropriate connection icon when the full re-scan has been completed. Your choice of whether to enable or disable periodic scans of attached NCE Cabs is saved by A-Track and will be applied each time the program is started.

Connecting your computer (and A-Track) to an NCE Power Cab, Smart Booster, or DCC Twin via an NCE USB Interface unit, will also result in both the left- and rightmost indicators turning **green**, assuming that the relevant NCE equipment is powered on.

However, when using an NCE Power Cab, Smart Booster, or DCC Twin as the Command Station, the third, middle indicator on the A-Track status bar will now be replaced by an icon showing the type of connected unit reported by the NCE USB Interface. Note that the NCE USB Interface does not actually identify the type of NCE equipment to which it is connected, but simply reports the current setting of its three active configuration jumper links (JP2, JP3, and JP3 – JP1 is not used). See the latest NCE USB Interface documentation for full details.

Important Note : When an NCE USB Interface is connected between the PC and a Power Cab, Smart Booster, or DCC Twin system, the USB Interface uses one of the available Cab Addresses. A Version 6 USB Interface always uses Cab Address 03, while A-Track will set a Version 7 USB Interface to Cab Address 10.

Hence, to prevent any interference and ensure correct system operation, you should make certain that none of your attached Handheld Controllers (Cabs) are set up with either Address 03 or 10, depending on the type of USB Interface being used.

Version 1.65 Power Cab systems reserve address 08, 09, and 10 for AIUs and like devices, and you can use addresses 03, 04, or 05 for connecting Handheld Cabs (address 02 is used by the Power Cab itself). When using a Smart Booster or DCC Twin system, addresses 02, 06, and 07 are also available for use by either Handheld Cabs or AIUs. Refer to your NCE system documentation for details of how to set the Address assigned to a particular Cab.

Connecting to an NCE Power Cab Version 1.65 through an NCE USB Interface results in the A-Track window shown below –

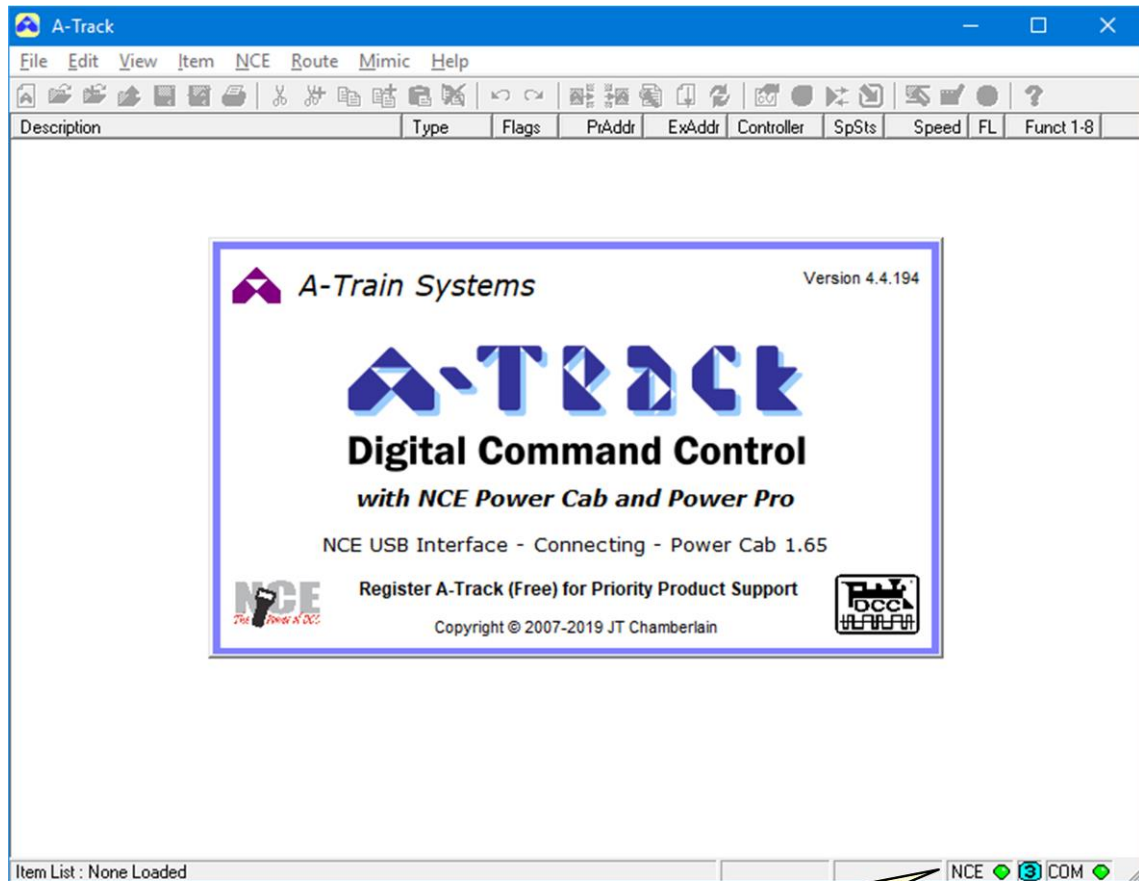

Connected to NCE Power Cab via an NCE USB (V7) Interface

The icon displayed in the middle indicator position on the A-Track status bar reflects the jumper link settings which are automatically read by A-Track when it is connected to the NCE USB Interface, and depends on which version of the USB Interface unit you are using, as well as the setting of the configuration links.

For the two versions of the USB Interface unit currently in use (Versions 6 and 7), the displayed icons are shown in the following tables. Note that jumper 1 (JP1) should always be set to OFF to ensure that the speed of the USB COM port (the connection to the PC) for the Version 6 USB Interface is maintained at 9600 bps –

NCE USB Interface Version 6 (pre-2013)

Icon	Connection	Jumpers	Icon	Connection	Jumpers
	Power Cab	All OFF		All Systems	JP3,4 ON
	Smart Booster	JP4 ON			
	Power Pro 2007	JP3 ON		Undefined	All other settings

NCE USB Interface Version 7 (2013 on)

Icon	Connection	Speed	Jumpers	Icon	Connection	Speed	Jumpers
	Power Cab Version 1.28c	9600	All OFF		Power Cab Version 1.28c	9600	JP2 ON
	Smart Booster SB5 / SB3a Version 1.65	19200	JP4 ON		Smart Booster SB3 / SB3a Version 1.28d	19200	JP2,4 ON
	Smart Booster SB5 / SB3a Version 1.65	9600	JP3 ON		Power Pro 2007	9600	JP2,3 ON
	Power Cab / DCC Twin Version 1.65	19200	JP3,4 ON		All Systems Version 1.65	19200	JP2,3,4 ON

Again, if you hover your mouse cursor over the status bar panels containing the NCE and COM indicators, pop-up labels will appear displaying, respectively, the NCE USB Interface Software Version , and which of your computer’s COM ports is currently being used by A-Track to connect to the Interface, together with the bit (baud) rate at which the serial link is operating, as shown below –

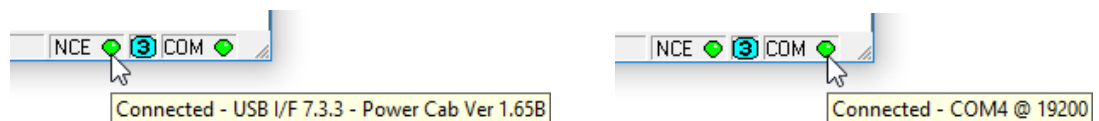

Note that, as here, when using a Version 1.65 NCE Power Cab system with a Version 7 NCE USB Interface, the System Type can actually be read from the Command Station and so can be displayed accurately. With a Version 6 NCE USB Interface and/or a Version 1.28 NCE Power Cab system, the System Type cannot be read from the Command Station, so can only be assumed from the state of the USB Interface configuration links.

Important Note : To ensure that A-Track will generate the correct set of commands when communicating with the NCE equipment, **it is essential** to set the NCE USB Interface configuration links so that their positions correspond to whatever type of NCE Command Station is connected to the other side of the NCE USB Interface. Failure to do this can cause the complete system to **lock up**. The position of the configuration links should **only** be changed when the NCE USB Interface unit is not powered, ie. disconnected from the Cab Bus (unplug the lead from the 6-pin RJ12 connector).

Since a Version 6 NCE USB Interface, regardless of the type of Command Station to which it is connected, does not provide access to the Command Station internal data store, A-Track is unable to access either the Consist data block or the status of any connected NCE Handheld Cabs (including a Power Cab and any attached Auxiliary Interface Units), and no subsequent data transfer or scan of Cabs or AIUs takes place.

If either the interface cable or USB-to-Serial converter is not plugged in, or the relevant NCE Command Station is not connected or switched on, when A-Track is started, then the status indicators will remain **red**. All program functions will be fully operational except, of course, those which deal directly with the NCE equipment.

Whenever a Command Station is subsequently connected, A-Track will proceed to identify automatically the type of NCE equipment which has been connected, and set both the left- and rightmost indicators to **green**. After connecting to an NCE Power Pro Command Station or to a Version 1.65 NCE Power Cab system with a Version 7 NCE USB Interface, A-Track will then retrieve the Consist data block and start the scan of the attached NCE Handheld Cabs (including Auxiliary Input Units), with the middle status indicator changing colour appropriately, as described previously. However, with any equipment connected via a Version 6 NCE USB Interface, A-Track will simply display the appropriate icon in place of the middle indicator.

Recommendation : The best way to establish a fully-reliable connection to an NCE Command Station is to connect the Command Station through the appropriate interface to your PC, power up both PC and NCE equipment, then start A-Track. If A-Track is already running on the PC before connecting and powering up the NCE equipment, ensure that **only** the main A-Track window is open.

Note that, once a connection has been established, if the NCE Command Station is disconnected or switched off, the leftmost indicator will change to **yellow**, returning to **green** when the unit is again operational. Be aware that A-Track can take up to 10 seconds to react to any change in the state of the Command Station.

If, at any time when A-Track is running, the interface cable is disconnected from the PC, then both of the left- and rightmost indicators will change to **yellow** within 2 seconds, returning to **green** within 10 seconds after the connection is re-established (and the Command Station is operational). However, it is recommended that the Command Station is **not** deliberately disconnected from the PC Serial or USB port while the A-Track program is running, to avoid any possible data corruption, although such disconnection will not result in any physical damage to the equipment.

If the switch-off, disconnection, or other communication error does occur at a critical time when data is being transferred to or from the Command Station, then the hardware or software may be left in a state from which an orderly recovery is not possible. This is very likely to occur if the disruption occurs during the A-Track initialisation period, or if the equipment is re-connected very quickly after any disconnection. In such cases, first disconnect the serial or USB cable, then close down A-Track (see **Section 4.3**), and switch off the NCE Command Station. Allow around 20 seconds for the Command Station to power down fully, then switch it back on, reconnect the cable to the PC, and start the A-Track program again.

With an NCE Power Pro Command Station, the middle status indicator will revert to **red** after any disconnection, then subsequently show **yellow** and **green** followed by the  icon after reconnection and completion of a full Handheld Cab status scan.

3.6 An Introductory Tutorial

Once A-Track has completed its initialisation, the start-up window disappears and will be replaced by a **Tutorial** window which you can use to get a feel for the basic facilities provided by the A-Track program, including how to access the key menus and functions, and which will then guide you through the first steps in using A-Track with your own roster of locomotives.

The opening page of the Tutorial is shown below, with its straightforward controls. Having read the first page, click on the **Next** button to display the next page. Thereafter, you can return to a previous page by clicking the **Back** button, which will then be enabled. For your information, the number of the **current page** is displayed in the bottom righthand corner of the Tutorial window.

If you want further information about the topic described on any Tutorial page then a click on the **More Info** button will open another window showing the appropriate section from the full **A-Track Help Topics** (the contents of this document).

You can stop viewing the Tutorial, and remove it from the screen, at any time by clicking on the **Close Window** button.

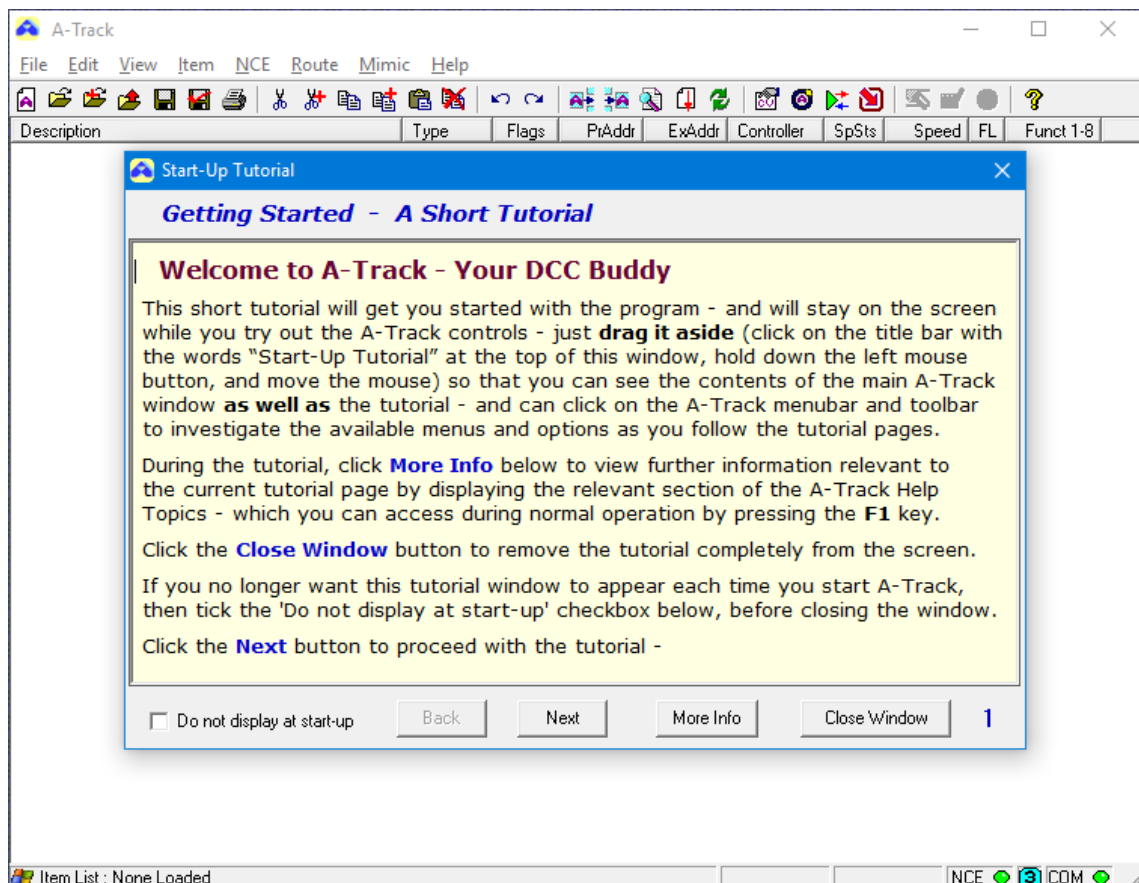

Although the Tutorial window is always displayed in front of the main A-Track window, you should drag it to one side, to leave the Tutorial window on the screen where you can see most of the main A-Track window as well the contents of the Tutorial (move the mouse pointer to the window title bar, where the text 'Start-Up Tutorial' is shown,

hold down the left mouse button, and move the mouse to drag the window to where you want it to be, then release the mouse button).

As you step through the Tutorial, various A-Track functions and features will be demonstrated, with additional windows being opened as necessary. It is important to note that all of the main A-Track controls, and those in all of the demonstration windows, are fully operational when the Tutorial is running, especially if an NCE Command Station is connected and powered-on (like the Power Cab Version 1.65 system indicated here). Hence, you are free to explore further, at any time, any particular A-Track feature which is of interest to you – which is by far the best way to get to grips with A-Track. You cannot cause any damage to the program or its files by doing so.

However, note that, after branching off on your own from the Tutorial, and changing the state of the loaded A-Track data, it may not be possible for the Tutorial to continue on its intended course when you click the **Next** or **Back** button. A message to this effect will be displayed, inviting you to click **Close Window**, after which you can, if you wish, restart the Tutorial by clicking on **Help** on the A-Track menu bar, followed by **Start-Up Tutorial** (See the menu details in **Section 12.8**).

The Start-Up Tutorial window will appear each time you start A-Track unless you click on the '**Do not display at start-up**' checkbox in the bottom-left corner of the window. At any future time after you have done this, the Tutorial window can be displayed once more from the **Help** menu by selecting **Start-Up Tutorial**.

If you want to print out any page shown in the Tutorial window for reference, you can highlight the text by using the normal Windows procedure with the left mouse button, copy the highlighted text (hold down either **Ctrl** (Control) key, then press the **C** key), and paste it into any word processor.

A more comprehensive set of Help pages (the full text of this Reference Manual) can be viewed by clicking on **Help / Help Topics** on the A-Track menu bar, or on the **?** icon on the A-Track toolbar, or by pressing the **F1** key on the keyboard at any time. Using the **F1** key will open the Help Topic most appropriate to the current A-Track activity in progress.

As noted in **Section 3.4**, you can also access the Help pages directly (without running the A-Track program) from the Windows Start Menu, by clicking on **Program Files**, selecting **A-Track**, then clicking again on **A-Track Help**.

From the Windows 8 Start Screen, the link to the A-Track Help file is revealed by right-clicking on a blank area of the screen, then on the '**All apps**' option, and then locating the **Help** entry in the **A-Track** group of tiles.

3.7 Making a Quick Start

If you do not wish to work your way through the complete Tutorial, the final part, which takes you through your first practical steps in using A-Track, where you can collect details from selected locomotives in your roster, is detailed in this Section of the Reference Manual for your convenience.

It is assumed that you have gleaned enough from the Tutorial to understand that the details of each of your locomotives (or other pieces of equipment) in your roster will be held by A-Track as an Item, with a group of Items forming an Item List. Full details of Item Lists, and of Item List operation, are covered later in **Chapter 4**.

Ensure that your computer is connected to, and communicating with, an operational NCE Command Station – either a Power Cab or Power Pro system – with the status indicators in the bottom righthand corner of the A-Track window showing **green**, as described in **Section 3.5** above.

Next, click on **File** on the Menu Bar, and then **New**, as shown below –

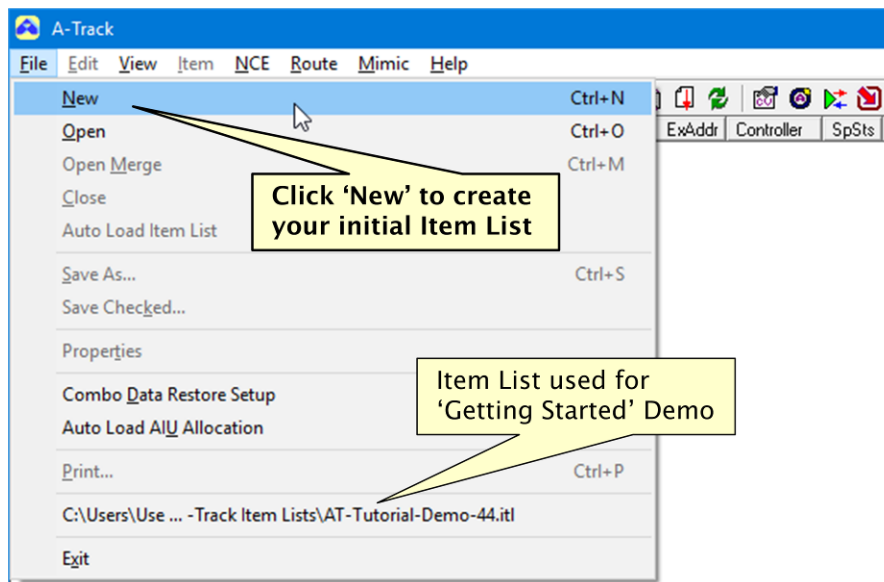

- which will create your first Item List, containing a single blank Item, that you can then use to collect full details of the first locomotive in your roster –

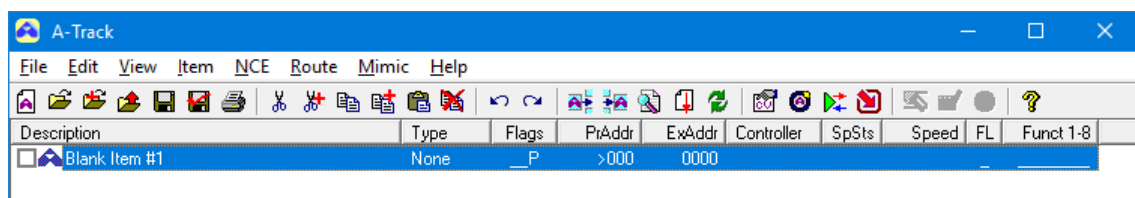

At this point you can, if you wish, click on **Edit**, and then on **Insert Blank Item**, to add further blank Items to match the number of locomotives you have. Alternatively, you can repeatedly click on the  icon on the Toolbar to perform the same operation – or you can leave this step until later –

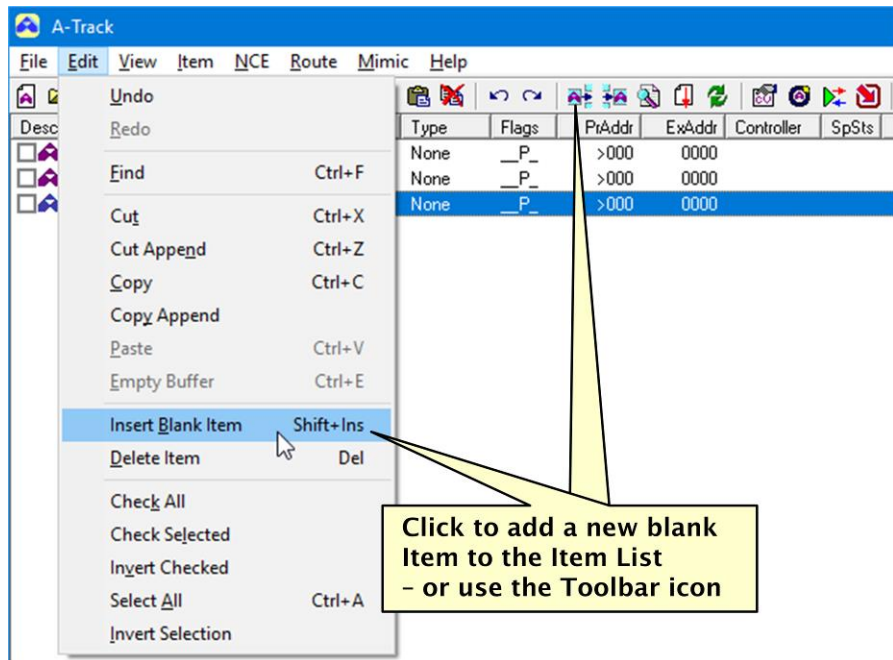

Now, **double-click** on one of the blank Items in the Item List – which will open an **Edit Configuration Variables** window. You can refer, in due course, to **Chapter 5** (Item Operations) for full descriptions and details of all of the features and functions to be found in the Edit CVs window.

For the moment, press the **F1** key on the PC keyboard –

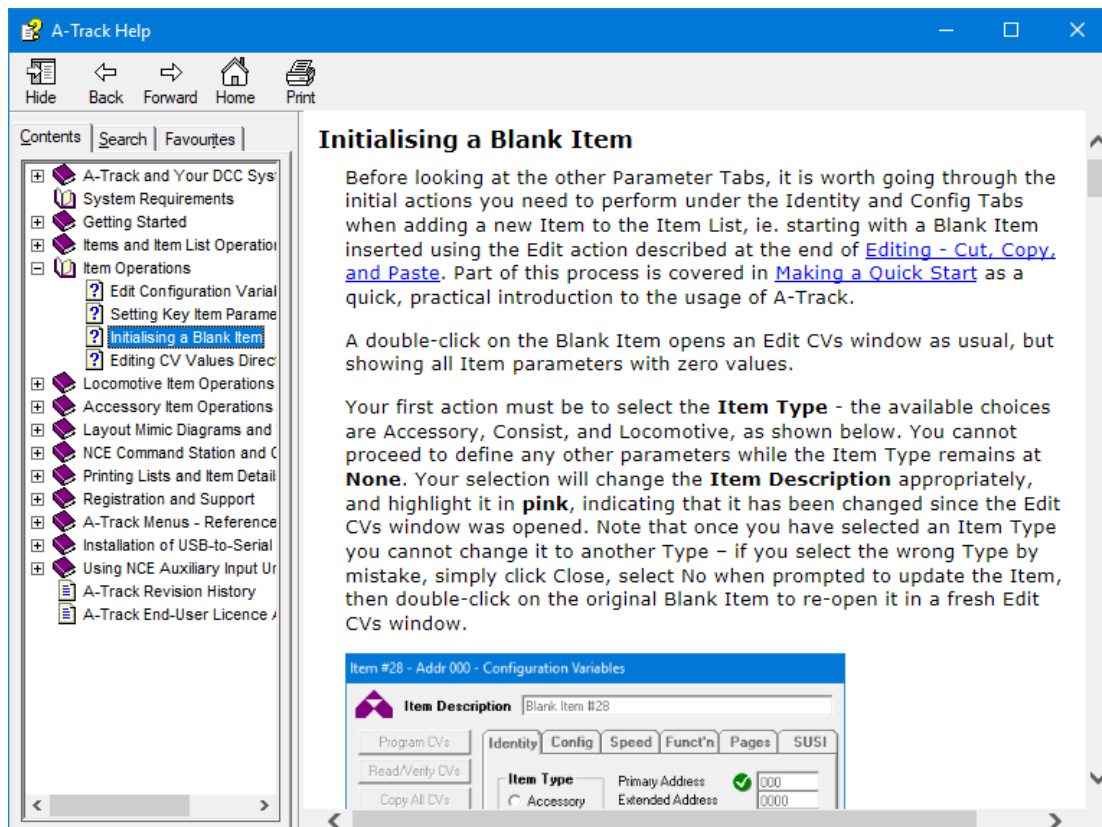

- which opens A-Track's **Help Topics**, and lets you access the instructions for 'Initialising a Blank Item' under 'Item Operations'. These describe the steps to change the blank Item into a Loco Item with a Description which matches one of your locomotives. The same information can be found in **Section 5.3** of this Reference Manual.

In accordance with the instructions, click on the **Locomotive** option in the **Item Type** section of the Edit CVs window, as the first step in entering your first locomotive's details into A-Track –

Item #3 - Addr 000 - Configuration Variables

Item Description: Blank Locomotive #3

Program CVs
Read/Verify CVs
Copy All CVs
Paste Main CVs
Paste Exten'd CVs
Paste Index'd CVs
Update Item
Close

Identity Config Speed Funct'n Pages SUSI

Item Type
 Accessory
 Consist
 Locomotive
 Multiple
 None

Primary Address: 003
 Extended Address: 0003
 Consist Address: 000
 User Identifier #1: 000
 User Identifier #2: 000
 Manufac Version No.: 000
 Manufacturer ID: 000

Not Allocated: 00 Edited: Not Prog'd

CV	0x	1x	2x	3x	4x	5x	6x	7x	8x	9x	10x	11x	12x
0	000	000	000	000	000	000	000	000	000	000	000	000	000
1	003	000	000	000	000	000	000	000	000	000	000	000	000
2	000	000	000	000	000	000	000	000	000	000	000	000	000
3	000	000	000	000	000	000	000	000	000	000	000	000	000
4	000	000	000	000	000	000	000	000	000	000	000	000	000
5	000	000	000	000	000	000	000	000	000	000	000	000	000
6	000	000	000	000	000	000	000	000	000	000	000	000	000
7	000	192	000	000	000	000	000	000	000	000	000	000	000
8	000	003	000	000	000	000	000	000	000	000	000	000	000
9	000	000	002	000	000	000	000	000	000	000	000	000	000

- then click in the **Item Description** box and type a suitable description for that locomotive, to replace the 'Blank Locomotive' caption which A-Track generates automatically.

Next, click on the **Pages** Parameter Tab, where you should click the **Specific Manufacturer** option button in the **Decoder Manufacturer** section.

If the make of decoder fitted appears in the drop-down list when you click on the down-arrow (▼) at the righthand end of the listbox, then click on that maker's name. Otherwise (or if you do not know the make of decoder) click the **Basic / Other (NMRA)** option button. Remember that full help with setting up Item details can be accessed by selecting the appropriate section of the A-Track Help Topics, displayed by pressing the **F1** key again if necessary.

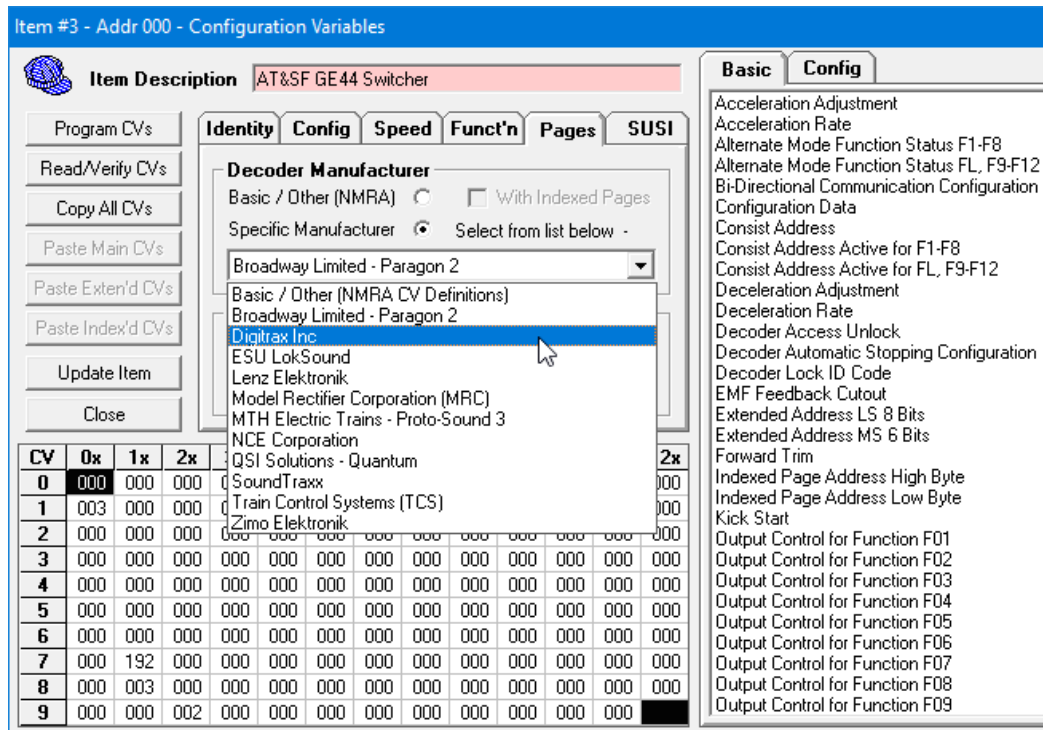

Before adding any more details to your newly-created Loco Item, the safe way forward is to click the **Update Item** button to save the basic Item back to the Item List.

With the first initialised Item shown in the Item List, you can repeat the same steps with each of any other blank Items you added to the new Item List, by double-clicking on them to open their own Edit CVs window, and finally saving the updated Items back to the Item List.

At this point, before proceeding to the next stage of collecting each Item's Configuration Variable values from the actual locomotives, it is a good idea to safeguard your initialised Item List, by saving it to a folder on your PC. To do this, click on **File** on the Menu Bar, followed by **Save As**, on the drop-down menu.

When the **A-Track - Save Item List** window appears, a suggested filename with today's date is displayed (**New-ItemList-24-December-17.itl** in this example) – you are free to change it to whatever other format you prefer.

If you ran the Tutorial to the stage of loading the demonstration Item List, then the destination folder offered will be **Documents / A-Track Item Lists** (otherwise **Documents** or **My Documents**), but you can select any other folder if you wish. Select a folder from the folder list in the lefthand pane in Windows Vista, Windows 7, Windows 8, or Windows 10 (as shown below), or click the down-arrow (▼) at the end of the **Save In:** listbox for Windows XP, or choose to create a new folder, into which to store the Item List (see **Section 4.2**) –

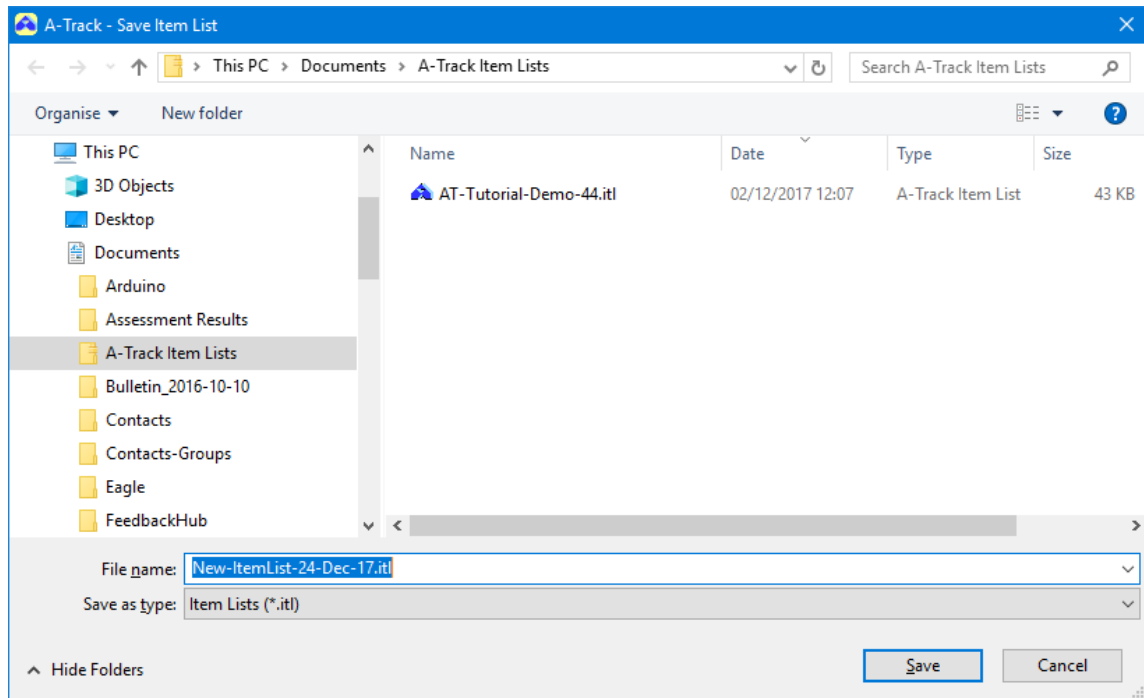

Once you are satisfied with the choice of destination folder, and the filename, click **Save** to save your new Item List file to the selected folder (or **Cancel** to abandon the operation).

The next step is to again double-click on your just-initialised Item in the Item List to re-open its **Edit CVs** window.

Now, place your first locomotive on your programming track (or, if you are using a Power Cab and do not have a separate, switched programming track as shown in the connection diagram in **Section 1.1**, ensure that it is the **ONLY** locomotive on the main track). Note that, if your locomotive has a sound decoder, and you are using an NCE Power Pro system, then you will generally need to connect a **programming booster unit** (such as the SoundTraxx PTB-100 or DCC Specialities PowerPax) between the Power Pro and the programming track – a booster is not usually required with an NCE Power Cab system.

Click the **Read/Verify CVs** button in the Edit CVs window to display the **Read/Verify Configuration Variables** panel where, for a first attempt at reading your locomotive decoder's CV values, you should set the **CV Range** and **Scope** options to **Current View** and **All CVs**, and the **Mode** to **Paged**. While Direct Mode will read CV values more quickly, it is not always supported, particularly in older decoders. Paged Mode is generally guaranteed to work but, the higher the programmed value of a CV, the longer it takes to determine the actual value of the CV from the decoder (since the Mode tries every possible value starting at zero until the trial value matches the actual CV value) –

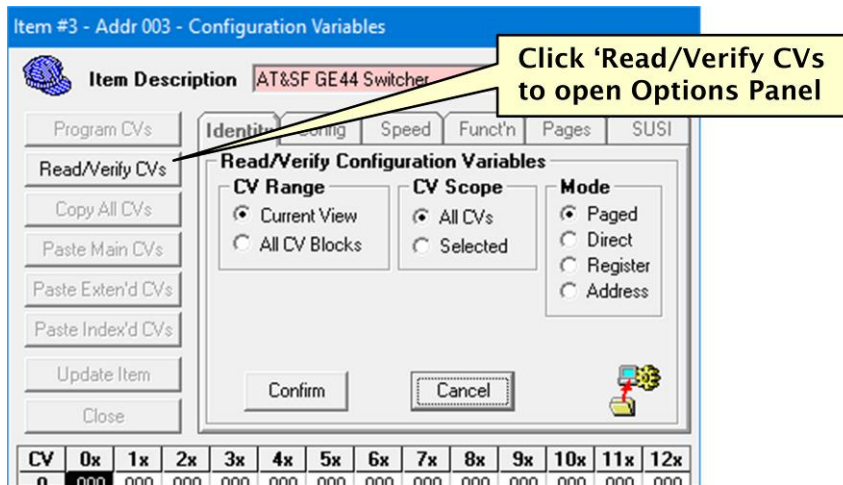

When you have set the options, click **Confirm** to start the Read/Verify operation.

During the Read/Verify operation, the CV currently being accessed will be highlighted in **red** in the grid in the lower half of the Edit CVs window. Once the CV value held in the decoder has been determined, it will be displayed in the grid and highlighted in **light green** if the value read is the *same* as that held in the Item, or highlighted in **pink** if it *differs* from the Item's stored value.

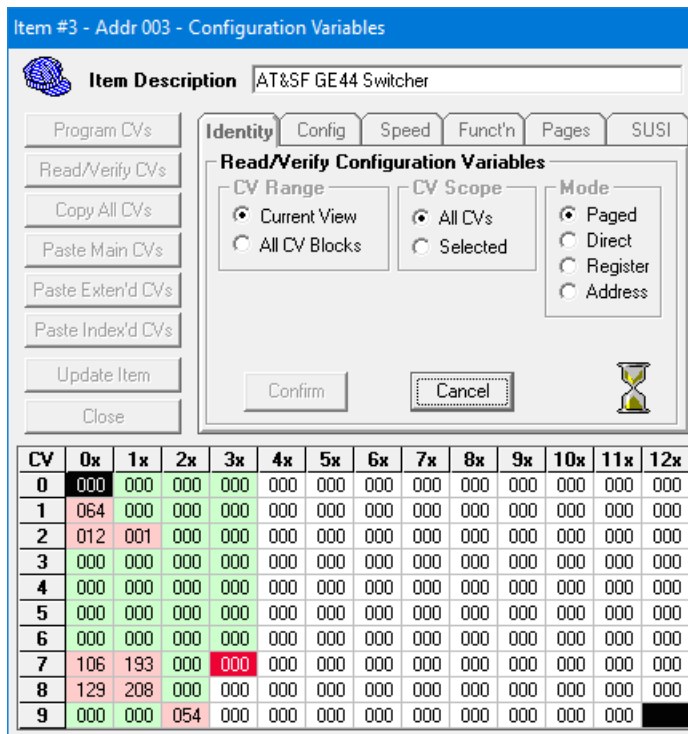

Wait patiently while the first 128 CV values are read from the decoder and displayed in the grid. If required, the whole operation can be stopped at any time by clicking the **Cancel** button, although you will have to wait patiently for the current CV Paged Read operation to complete (up to 20 seconds).

If you need further assistance with the Read/Verify operation, you can read the instructions in the Help Topic 'Item Operations - Reading and Verifying CV Values' (press the **F1** key to open up Help again if you closed it down), or refer in this Manual to **Section 6.6**.

When the Read/Verify operation is complete click the **Finish** button in the Edit CVs window. If an error occurred because of a connection problem, correct it and restart the Read/Verify operation (this is fully explained in the Help Topic).

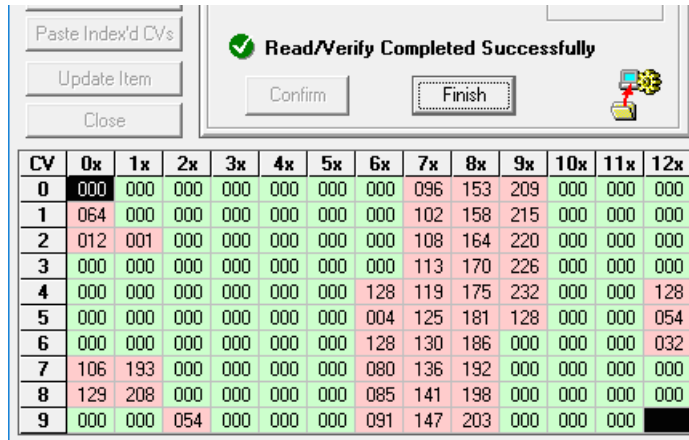

The screenshot shows a dialog box with a green checkmark and the text 'Read/Verify Completed Successfully'. Below the text are 'Confirm' and 'Finish' buttons. To the left of the dialog box are buttons for 'Paste Index'd CV's', 'Update Item', and 'Close'. Below the dialog box is a table of CV values.

CV	0x	1x	2x	3x	4x	5x	6x	7x	8x	9x	10x	11x	12x
0	000	000	000	000	000	000	000	096	153	209	000	000	000
1	064	000	000	000	000	000	000	102	158	215	000	000	000
2	012	001	000	000	000	000	000	108	164	220	000	000	000
3	000	000	000	000	000	000	000	113	170	226	000	000	000
4	000	000	000	000	000	000	128	119	175	232	000	000	128
5	000	000	000	000	000	000	004	125	181	128	000	000	054
6	000	000	000	000	000	000	128	130	186	000	000	000	032
7	106	193	000	000	000	000	080	136	192	000	000	000	000
8	129	208	000	000	000	000	085	141	198	000	000	000	000
9	000	000	054	000	000	000	091	147	203	000	000	000	000

If all went well, you may now wish to read all of the decoder's CVs by changing the **CV Range** option to **All CV Blocks**, and perhaps the **Mode** to **Direct**.

Click the **Update Item** button at any point to save the Item's CV data back into the Item List and close the Edit CVs window. Repeat the operations as often as required to obtain the full set of CV values currently programmed into this locomotive's decoder, then use **File / Save As** to save the updated Item List as your reference before making any of your own changes to the locomotive decoder's CV settings.

Repeat this acquisition of CV Values for all of your locomotives, then again click **File** and **Save As** to save your Item List - which is now a record of the original setups of your locomotive roster, and which (if you keep it safe) will give you the ability to restore these settings should any later changes you make to CV values prove to be less than optimum.

There is no need to complete the recording of your locomotive roster's decoder setups in a single session. You can close A-Track at any point by using the standard Windows **Close** button (✖ or ✕) in the top righthand corner of the window, or by clicking **Exit** from the File menu. If necessary, A-Track will prompt you to save any changes you have made to the Items or Item List before closing the program.

When you are ready to continue with A-Track, you can start the program again as explained previously in **Section 3.5**.

Alternatively, if you are intending to resume work with a saved Item List, you can simply locate the Item List file in the folder where you saved it, and then **double-click** on the file. This will open A-Track and load the Item List with a single action.

4 ITEMS AND ITEM LIST OPERATIONS

A-Track operations are based completely around a list of **Items**. Each Item represents a real DCC decoder which can be programmed or controlled on the model railroad layout, using DCC commands issued via whichever type of NCE Command Station is connected to your computer. **Items** include each locomotive in your roster, each definition of a consist, ie. a set of several locomotives to be controlled as a single unit, and any accessories such as remotely-controlled turnouts or signals.

Groups of Items are collected together in an **Item List**. Each entry in the Item List contains a description of the Item with its key parameters, including the values of all of the Item's decoder Configuration Variables (CVs), and the type of DCC decoder fitted in the Item. Specifying the type of decoder is most important where a sound decoder is fitted, since this affects the method which A-Track needs to use to program the Item CVs.

Once an Item List is constructed, the user can view and edit its composition, adding or removing Items as required, or selecting any individual Item in order to control it or to amend that Item's operational parameters.

Item Lists can be stored on, and retrieved from, the PC's hard disk (or any other type of storage medium which can be accessed by the PC) by the A-Track program. The key advantage of A-Track is that you can easily view the complete set-up of any Item's decoder, compare it to other similar decoders, and perform complex settings, such as function re-mapping or defining speed tables, much more easily than trying to do so when you only have access to a single CV value in one decoder at a time.

You are also not totally reliant on the retention by the Command Station and individual decoders of your Item settings between operating sessions on the layout. Backups of your Item List files can be made easily on to removable media such as USB flash drives (memory sticks) or CD-R disks, and stored elsewhere for security. If any decoder has its settings corrupted for any reason, it is a matter of minutes to use A-Track and the appropriate stored Item List to re-program and restore the decoder to its previously programmed state.

It cannot be over-emphasised that you should always keep back-up copies of your Item Lists – at least in a separate folder on your PC's hard disk and preferably in a physically-separate location. Then you will always be able to recover, not only from major disasters, but also from inadvertent editing errors made when using A-Track.

Although, in theory, given the size of hard disks and the amount of RAM in a modern PC, there is essentially no limit to the size of Item Lists which can be handled by A-Track, an upper limit of 32704 Items per Item List has been set in the software. This limit should be more than adequate to build Lists for all practical purposes – even in Clubs with very large locomotive rosters.

However, very large Lists tend to be unwieldy to view and manipulate so, while you may choose to keep a master reference Item List containing every Item of your (or your Club's) roster, it is usually more convenient, for day-to-day use, to compile shorter Item Lists – corresponding, for example, to an operating session. The Item List operations available in A-Track allow you to create these working Item Lists, either directly from your master List or from scratch, and to copy and move Items easily from one Item List to another.

4.1 Accessing and Viewing Item Lists

To illustrate the features of A-Track, an example Item List has been provided as part of the A-Track installation, (**AT-Tutorial-Demo-44.itl**). Although this file will have been installed into the folder **C:\Program Files (x86)\A-Track\Example_Item_Lists**, it is **not** a good idea to try to open the Item List directly from this system folder location because of file security restrictions which may be imposed by Windows Vista and above. These restrictions are likely to prevent you saving any changes back to the file, or saving any changed version of the file back to the folder location.

To avoid such difficulties, when A-Track is first run, all of the demonstration files and, in particular, the demonstration Item List, **AT-Tutorial-Demo-44.itl**, will have been copied to a subfolder, **A-Track Item Lists**, created within your main **Documents** (or **My Documents**) folder, and you are free to access it there.

If this does not fit in with the way you wish to manage your files and folders, then you should create the same (or a similar) folder either within another part of your User area or on another drive on your computer, and copy the demonstration files to this location from the **C:\Program Files (x86)\A-Track\Example_Item_Lists** folder (an example of creating a new folder is shown in **Section 4.2**).

Although the Tutorial described in **Section 3.6** will guide you step-by-step through the basics of accessing Item Lists, you can, if you wish, investigate the process directly by moving the Tutorial window out of the way (or closing it entirely), then clicking on **File** on the Menu Bar of the main A-Track window to reveal the File menu, where you should click on **Open**, as shown below. Item Lists can be accessed and edited whether or not your NCE equipment is connected to the computer.

See **Chapter 12** for itemised, detailed descriptions of the relevant File, Edit, View, and Item menu entries which cover most aspects of handling the Item List.

As with other standard Windows applications, you can also access the File menu by pressing **Alt-F** on the keyboard (hold down the *left Alt* key and then press the **F** key), followed by a press of the **O** key, or by pressing **Ctrl-O** directly (hold down either **Ctrl** (Control) key and then press the **O** key) -

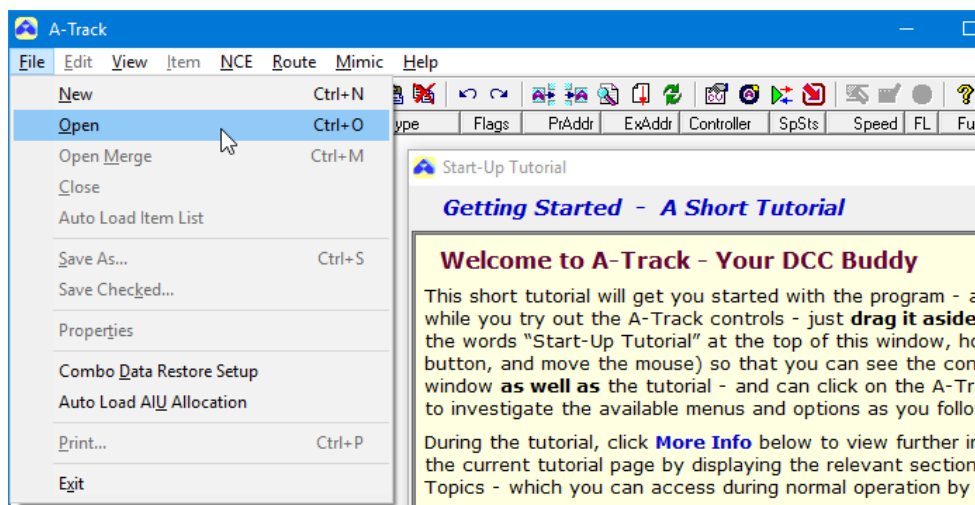

In the standard File Open window which then appears, locate the folder containing the copied Item List(s). If the folder is in your Documents area, then it should be

immediately visible, and the copied Item List(s) can be revealed with a click on the folder name.

Alternatively, if you have put them somewhere else, then drop down the folder list from the '**Look in**' listbox in Windows XP, or shown in the lefthand pane in Windows Vista, 7, 8, or 10, and then progressively select folders and subfolders until you reach the Item List folder (**A-Track Item Lists** here) –

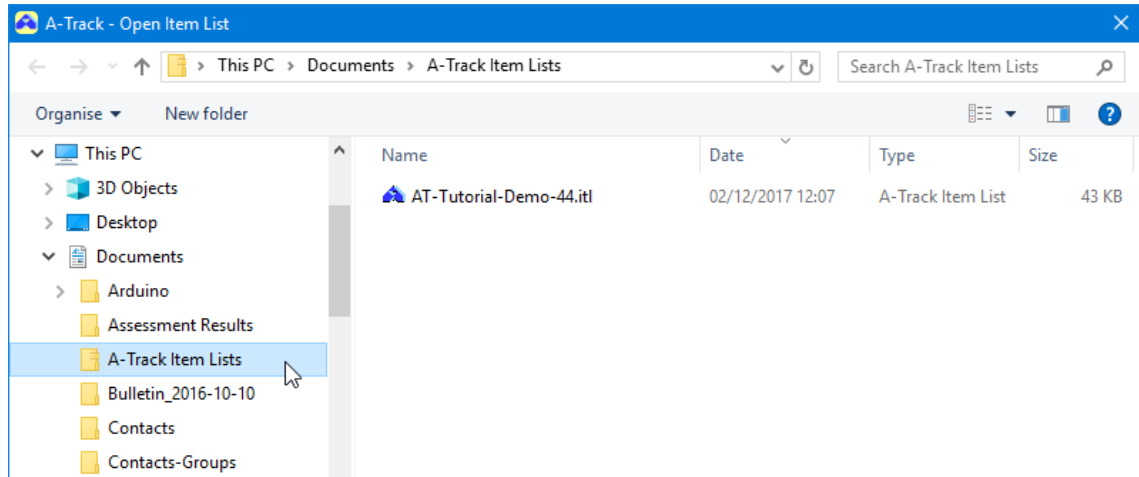

Select an Item List from the **A-Track Item Lists** folder, by clicking on the filename, and click on **Open** to load it (or just double-click on the filename) -

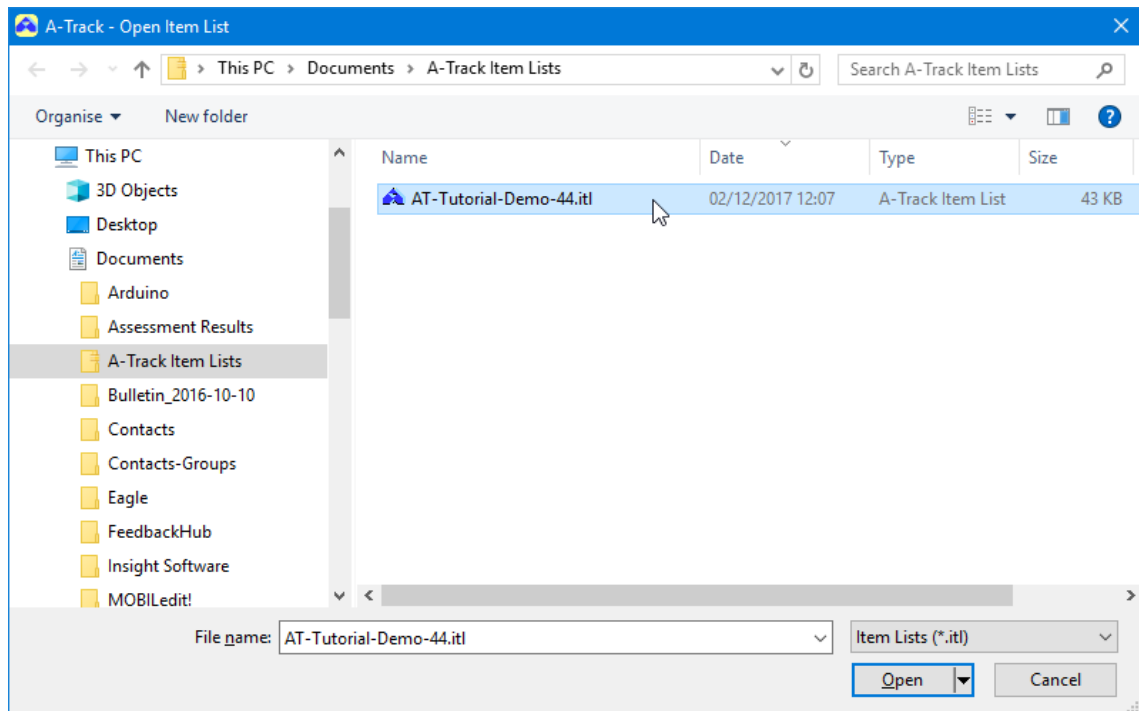

- which will display its contents in the A-Track main window, the significant features of which are indicated in the picture on the following page.

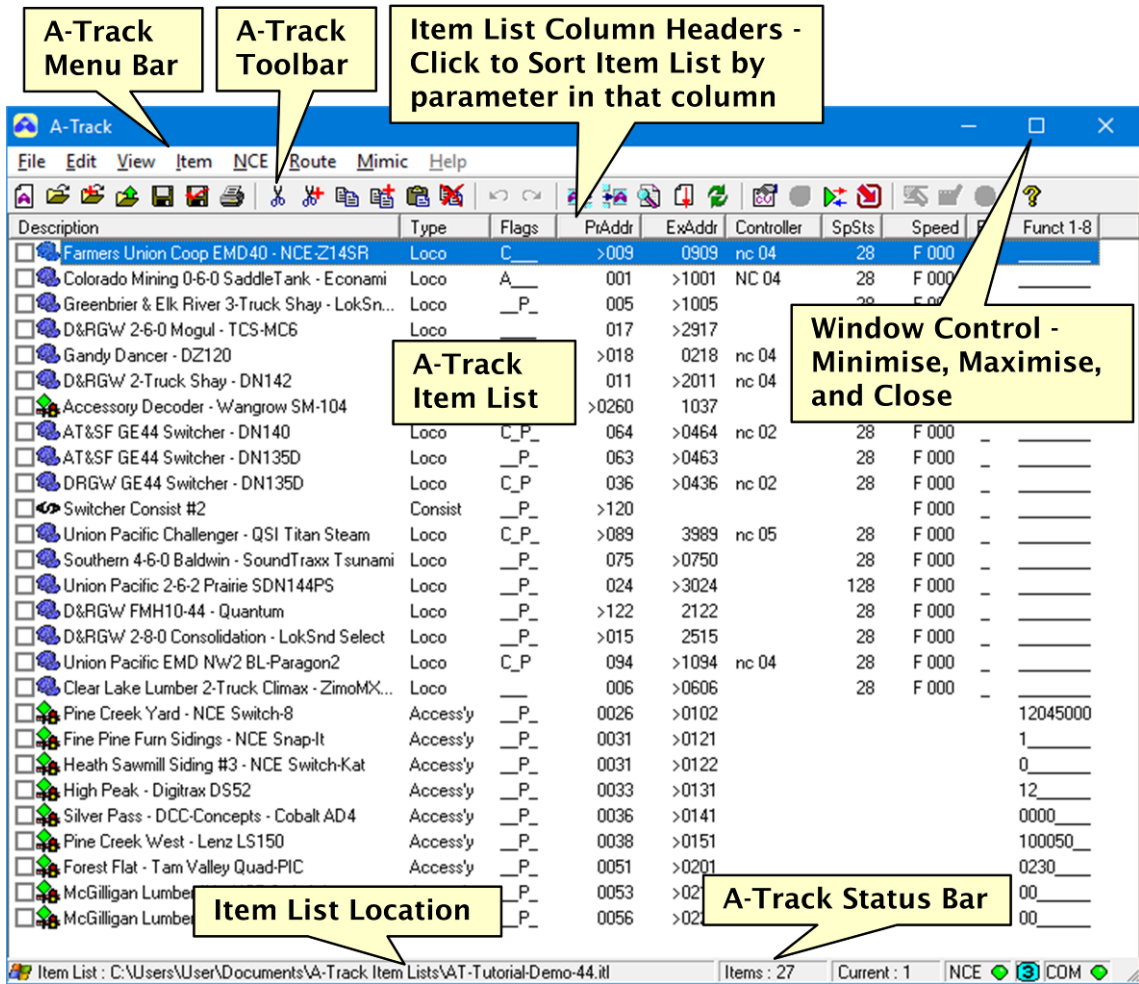

Be aware that, whenever an Item List is loaded, and you are connected to an NCE Power Pro or Power Cab / Smart Booster Version 1.65 (including DCC Twin) Command Station, a fresh scan of the status of connected NCE Handheld Cabs is launched. At this point, the lefthand panel of the status bar will turn **red** and will show the details of each accessed Cab, as shown in the examples below, with the middle connection status indicator first showing **red**, before intermittently turning **yellow** and **green**, and finally being replaced (when the scan is complete) with an icon showing the type of system connected -

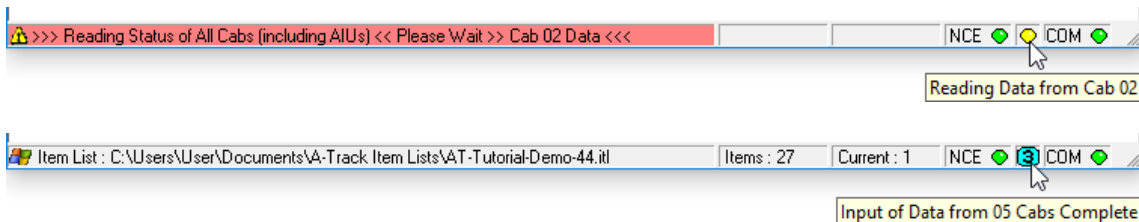

Note that, as an alternative to first opening the A-Track program, and then opening the Item List with which you want to work, you can simply locate the Item List file in the folder where you saved it, and then **double-click** on the filename. This will immediately open A-Track and load the Item List with a single action.

If A-Track is already loaded, then the Item List which is double-clicked will **replace** any Item List which is currently open in A-Track. You will be prompted to save any changes which might have been made to the currently-open Item list before it is replaced.

Once an Item List is loaded, the **pathname** of the Item List file is displayed on the **Status Bar** at the foot of the A-track window, as shown above. If, for any reason, the Status Bar is not visible, then open the **View** menu (see below) and check that the **Status Bar** entry is ticked – if not, then click on the entry to tick it and hence activate and display the Status Bar.

A-Track records the folder location of the most-recently-opened Item List so that, the next time you click **Open** on the **File** menu, A-Track will take you directly to this folder.

By default, A-Track displays a **Details** view of the Item List where each row shows a description and key parameters for each Item in the List. There are alternative views available which show less detail, and may be useful when trying to find a particular Item in a long Item List. Click on the **View** menu to access the available options -

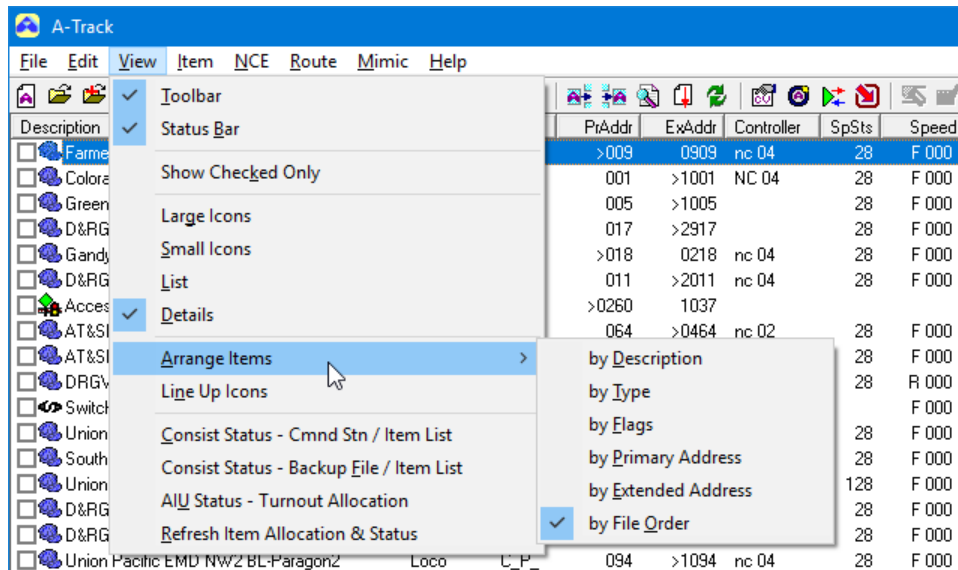

When using the alternative views (**Large Icons**, **Small Icons**, and **List**, as shown below), the **Arrange Icons** sub-menu is employed to select the sort order of the displayed Items. Click on one of the sub-menu options (such as **by Primary Address**) to sort the Item List using this Item parameter. Clicking the same sub-menu option again will re-sort the Items in the opposite sense, ie. the List will change from ascending order to descending order, or *vice versa*.

In the **Details** view you can sort the Items simply by clicking on the heading text at the top of each column for the categories shown. Having clicked on a column header, clicking again on the same header will reverse the Item sort order.

A-Track will arrange all subsequently loaded Item Lists using the View settings you select until you pick a different view. You can change the width of each column in the Details view to suit your own preferences – use the standard Windows technique of

clicking on, and then dragging, the boundary between each column header to the left or right as required.

Both the **List** and **Small Icons** views show only the Icon plus Description for each Item, set out in one or more columns, the number of columns being dependent on the number of Items in the Item List and the window height and width –

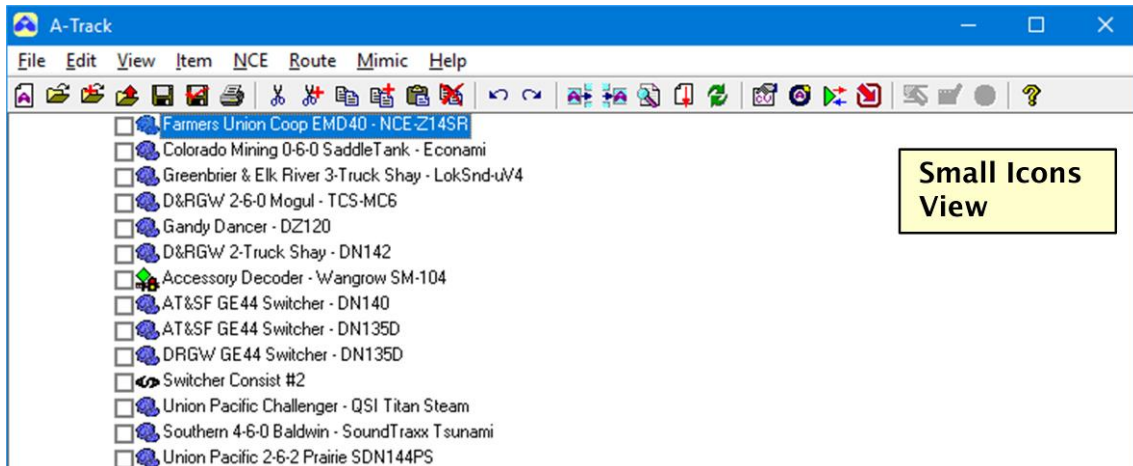
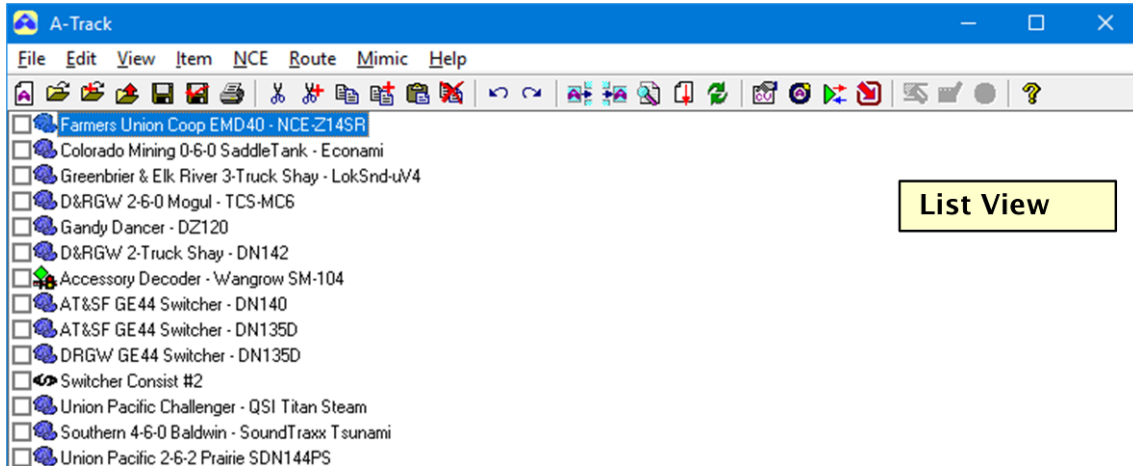



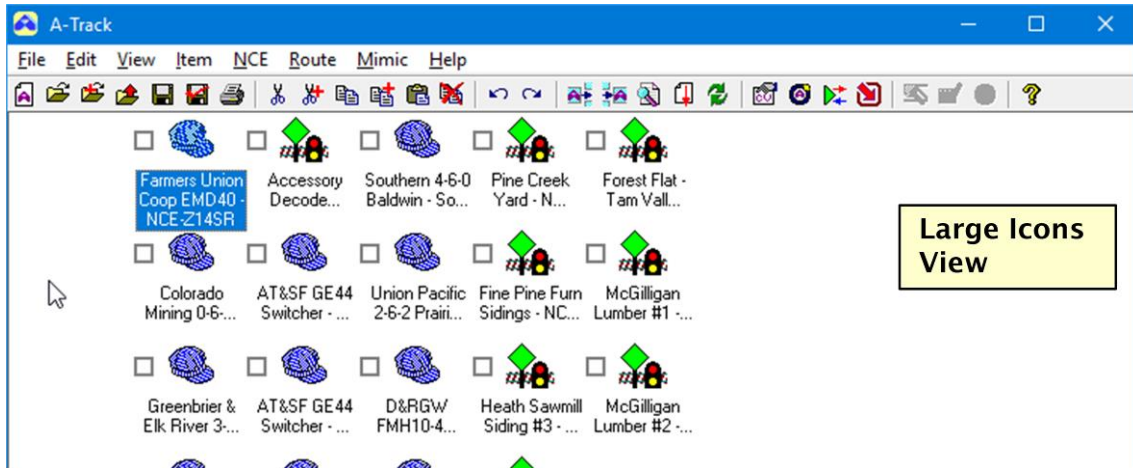

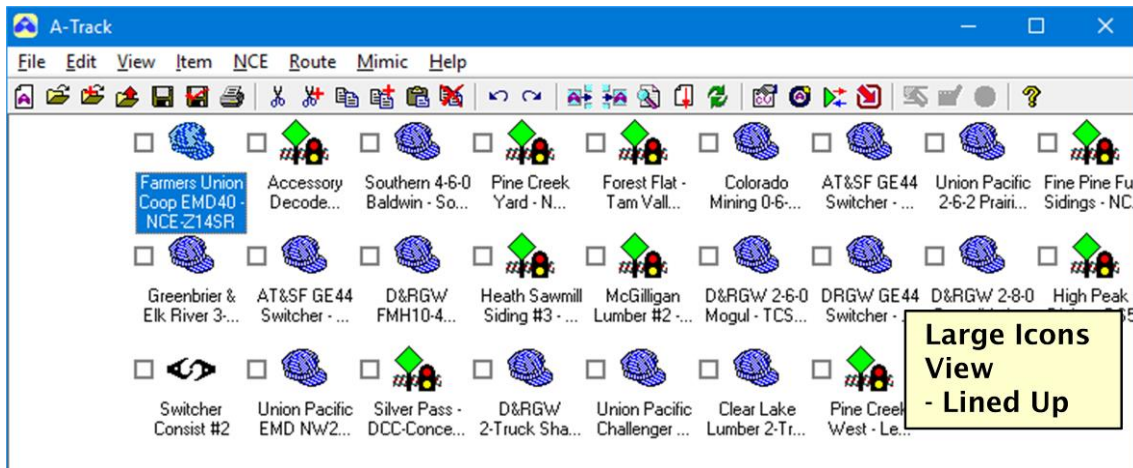

The **Large Icons** view, as its name implies, shows larger versions of each Item’s Icon, with the Description below the Icon and checkbox –



You can use the **Line Up Icons** option from the View menu to increase the number of columns to fill up the window width for both the Small Icons and Large Icons views –



Note that the following icons are used to identify different types of Items –

	Locomotive		Multiple – Lead Loco (Loco assigned to a Consist)
	Consist (Group of Locos)		Multiple – Mid Loco
	Accessory (Turnouts or Signals)		Multiple – Rear Loco

Of those **View** menu options not covered so far, **Toolbar** simply enables display of the row of command icons located immediately below the Menu Bar (each icon corresponds to a selected option from one of the A-Track menus). Clicking **Toolbar** will

disable display of the icons, removing the tick beside the option. Click again to re-enable display of the Toolbar.

Show Checked Items only displays those Items where the checkbox to the left of the Item has been clicked to show a tick. It is useful when selecting a subset of Items from a long List in order to check whether all required Items have been marked. Click the option again to re-enable display of the complete Item List.

Consist Status – Cmnd Stn / Item List allows you to review all of the consists currently defined in the Item List and in an NCE Command Station (Power Pro or Power Cab V1.65), if connected. Full details are covered in **Section 6.12**.

Consist Status – Backup File / Item List is only relevant if you have backed up Consist data from the Item List or an NCE Command Station to a file stored on your computer. If so, you can then review all of the consists held in the file with those currently in the Item List. Full details are covered in **Sections 6.12** and **9.3**.

AIU Status – Turnout Allocation allows you to allocate and/or view which turnouts on your layout are connected to which inputs of one or more Auxiliary Input Units (AIUs) connected to the Cab Bus of an NCE Command Station (Power Pro or Power Cab V1.65). The defined turnout allocations can be stored in, or retrieved from, a file on your computer. Full details are covered in **Section 7.4**.

In the standard A-Track installation, automatic status updates of the NCE Cabs attached to the Command Station are disabled by default. However, you can update the displayed Cab allocation and status at any time by clicking the **Refresh** (🔄) icon on the A-Track toolbar or by clicking on **View** on the A-Track menu bar, followed by **Refresh Item Allocation & Status** (See **Sections 3.5, 9.4, and 12.3**).

When you use the **View** menu option, you will be asked whether you wish the periodic scan (approximately every 6 minutes) of attached NCE Cabs to resume –

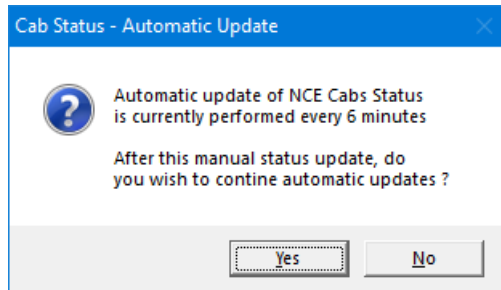

Click **Yes** to enable future automatic scans of NCE Cab status, or **No** to leave the scans disabled. Leaving scans disabled is preferred if you want to adjust the setup of the NCE Power Pro Command Station or Cabs, or change Consist or Macro settings without being interrupted periodically, since all editing functions are disabled during the scan). Further details of the way in which the NCE System Status data is handled can be found in **Chapter 9**.

A **tick** mark next to the **Refresh Item Allocation & Status** option on the View menu will be displayed to indicate that periodic scans of attached NCE Cabs are enabled. In this state, every 6 minutes, A-Track will automatically re-scan the status of the NCE Cabs attached to the Command Station. The current Cab allocation and status will be cleared from the Item List, with the lefthand panel of the status bar turning **red** and

showing the details of each accessed Cab. The middle connection status indicator will intermittently show **yellow** and **green**, finally being replaced (when the scan is complete) with an icon showing the type of system connected.

Your choice of whether to enable or disable periodic scans of attached NCE Cabs is saved by A-Track and will be applied each time the program is started.

Note that, regardless of the setting of the automatic status update option, the Cab allocation and status will be updated each time a new Item List is loaded, or when changes are made through A-Track to the allocation of Items to attached Cabs (See **Section 6.8**).

4.2 Item List Load and Save Options

As introduced in the preceding section, all Item List Load and Save operations can be performed using the functions available from the File menu, some of which have alternative access via keyboard shortcuts and/or toolbar icons (see **Section 12.1** for full details). As an example, you can click the  icon on the Toolbar to load (Open) an Item List, or press **Ctrl-O** on the keyboard (hold down either **Ctrl** (Control) key and then press the **O** key) to perform the same operation.

Once an Item List has been opened, its filename is added to the **Most Recently Used** (MRU) list on the File menu as shown below. Up to eight filenames can be displayed in the list – when you open the ninth distinct Item List then the oldest filename is dropped from the list to make way for that of the latest Item List.

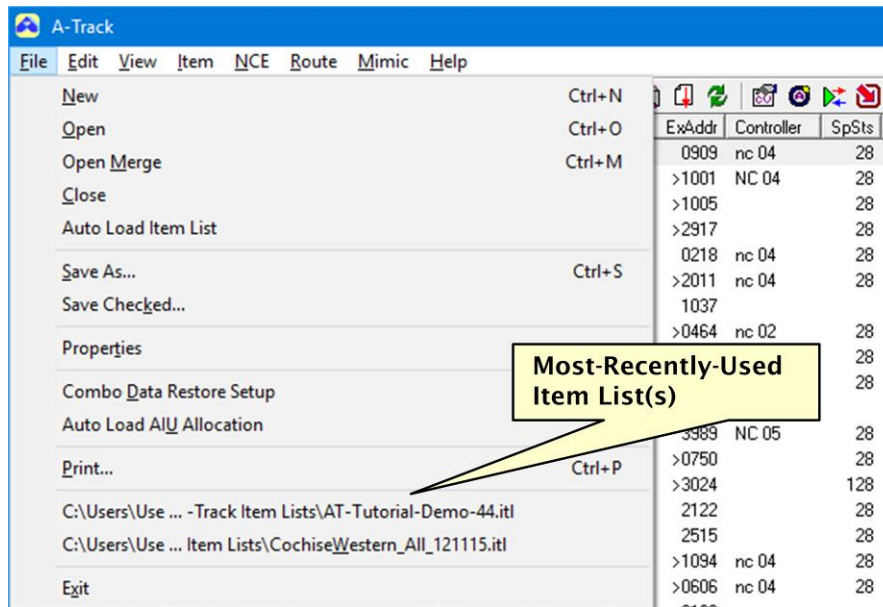

Once an Item List appears in the File menu MRU list, you can open this Item List at any subsequent time simply by clicking on its filename in the MRU list, without having to go through the standard File Open window.

Unless you have a very large roster of locomotives, it is likely that you will use a single Item List for most A-Track operations. In this case you can set A-Track to load this List automatically whenever you run A-Track. Simply load your Item List as described above then click on **File** to open the File menu and then click on the **Auto Load Item List** option (or the  icon on the Toolbar) –

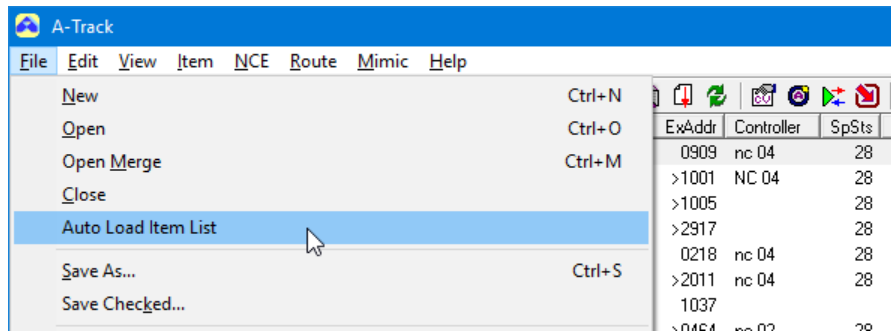

A prompt will be displayed, asking you to confirm your choice –

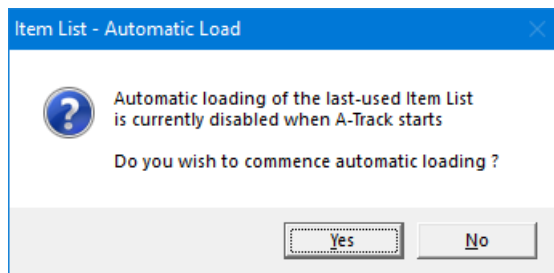

Click **Yes** to confirm future automatic loading of the Item List, and to place a tick mark next to the **Auto Load Item List** option in the **File** menu, or **No** to keep the option disabled.

If you subsequently wish to cancel automatic loading, just click again on the **Auto Load Item List** option (or the  icon on the Toolbar) then click **Yes** in the confirmation window this time to disable the option.

As well as opening an existing Item List, you can use the File menu to generate a completely new Item List by clicking on **New** (or the  icon on the Toolbar, or by pressing **Ctrl-N** on the keyboard), which creates an Item List containing a single Blank Item. If an Item List is already loaded and has been changed in any way, then you are asked whether you wish to save the current Item List before it is replaced with the new Item List –

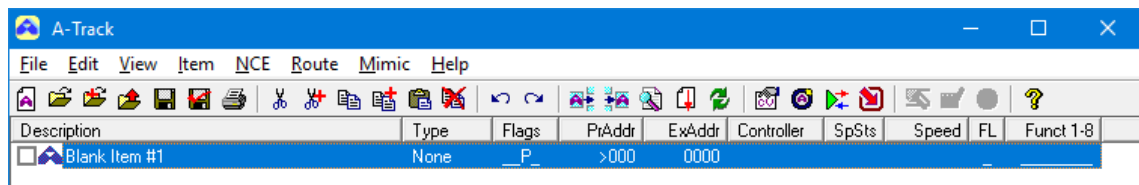

Having generated a single Blank Item, the next thing to do is to change it into a valid DCC Item having an Item Type of Locomotive, Consist, or Accessory. You should also give the Item a unique Description and Address. The sequence of operations to perform these actions has already been introduced in **Section 3.7**, and is covered later in more detail in **Section 5.3**.

When you have finished adding to the Item List, or editing individual Items (see **Chapter 5**), you can save the finished Item List to disk by clicking **Save As** on the File menu (or the  icon on the Toolbar, or by pressing **Ctrl-S** on the keyboard) –

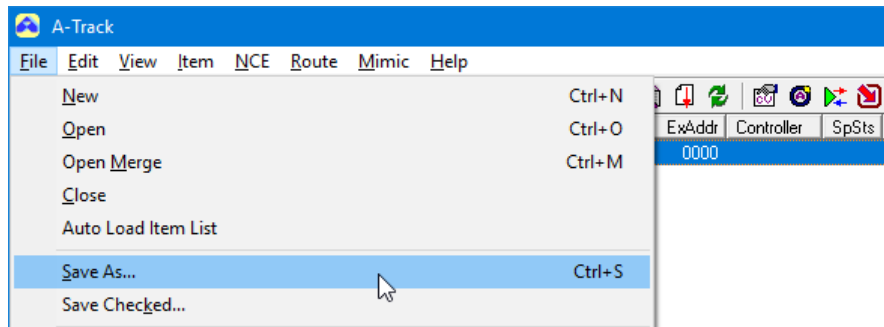

– which opens the standard File Save window, as shown below –

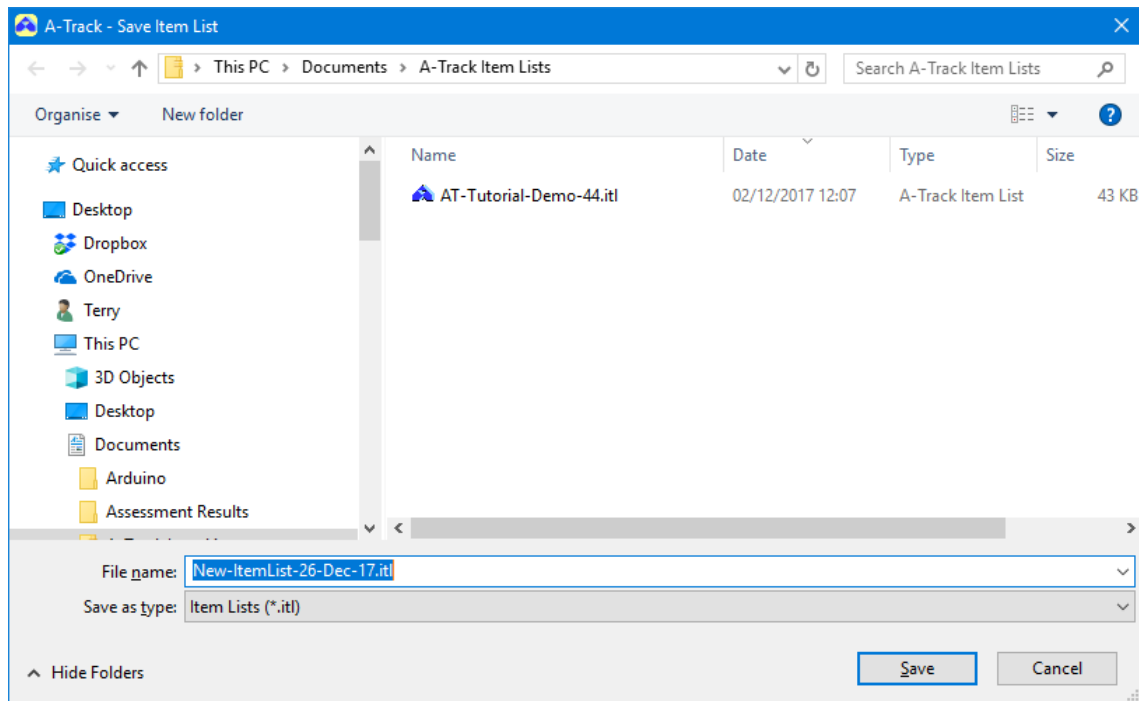

A-Track opens the folder from which the last Item List was opened (or your main Documents or My Documents folder if no Item Lists have yet been opened), and generates a default filename, which includes today's date, as shown.

If you wish to save the Item List under a different filename, click in the **File name** textbox to highlight its contents (if not already highlighted – as shown above), then simply type the new filename to replace the displayed filename. Click **Save** to save the Item List under the given filename, which will have a file extension of **.itl** added to identify to Windows that the file is an A-Track Item List.

Note, however, that if you have chosen to save the edited Item List under a filename which is the same as that of a file already in the selected folder, then Windows will display a warning –

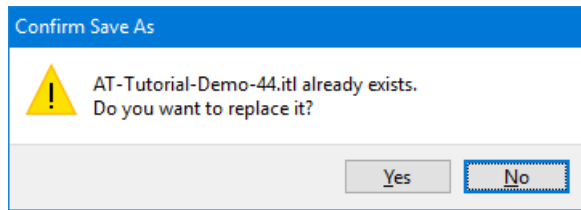

- and it is your choice on how you wish to proceed – click **Yes** to replace (overwrite) the file with a new version, or **No** to return to the **Save Item List** window where you can either rename the file, or select a different folder in which to save it (or abandon the whole Save As operation).

Rather than save a complete Item List to a file, A-Track also offers the capability to save only selected Items from the List. To choose the Items to save to a file, click to tick the checkbox located to the left of each Item which you wish to include, then click on **Save Checked** on the File menu (or the  icon on the Toolbar).

In the File Save window which then opens, type an appropriate filename for the reduced Item list, and click **Save**. You could, of course, just use the existing filename **but** by doing so you will overwrite the existing Item List and **permanently lose all of those Items which were NOT checked** – so make very sure that you really want to eliminate them.

If you maintain a number of separate small Item Lists stored on disk, then you can use A-Track to amalgamate them into a single large Item List, perhaps for archiving or back-up purposes. Do this by clicking on **Open Merge** on the File menu (or use the  icon on the Toolbar, or press **Ctrl-M** on the keyboard) after you have opened the first Item List in A-Track. This will display the standard File Open window, just as for Open (see **Section 4.1** and above), to allow you to select a second Item List. Opening this Item List will **add** its Items to the end of the first Item List.

You can continue to append Item Lists in this fashion up to the limit of 32704 Items, and, since each Item occupies less than 2 kilobytes, Lists of even thousands of Items are unlikely to fill more than a fraction of the available memory in a modern PC. If you attempt to add a further Item List to the current Item List such that the total number of Items would exceed the maximum allowed, then only part of the further Item List will be loaded to bring the combined number of Items up to 32704.

The recommendation, of course, is that you do not create such very large Item Lists since they will be very awkward to use and edit. Bear in mind also, that the NMRA DCC Standards limit the maximum possible number of Item Extended Addresses that you can use to 16383, together with 127 Primary or Consist Addresses, so that Item Lists with more than 16510 Items must contain Items with the same (conflicting) address. Most commercial DCC systems reduce the maximum number of Extended (4-Digit or Long) Addresses which can be used to 9999, which suggests this value as an upper practical limit on Item List length.

While merged Item Lists have the same structure and format as any other Item List, and can be stored with the same **.itl** file extension, you may like to treat them as a master or reference List, or **Item Archive**. For convenience, A-Track provides the facility to use a different file extension, **.ita**, for any large, or merged, Item List that you wish to treat as an Item Archive.

After you have created a merged Item List or Archive you can add further Item Lists to it at any time using **Open Merge**, or extract smaller Item Lists from it by using the **Save Checked** option.

While there is nothing to stop you saving your merged file (under a different filename, of course) in the same folder as your other Item Lists, it is a good idea to create a separate folder to hold such merged Lists especially if they are to be regarded as Archives. Start by opening the File menu, and clicking on **Save As**.

If using Windows XP then, in the Save Item List dialog window which opens, locate a suitable parent folder (such as **My Documents**) using the drop-down **Save in:** listbox at the top of the window –

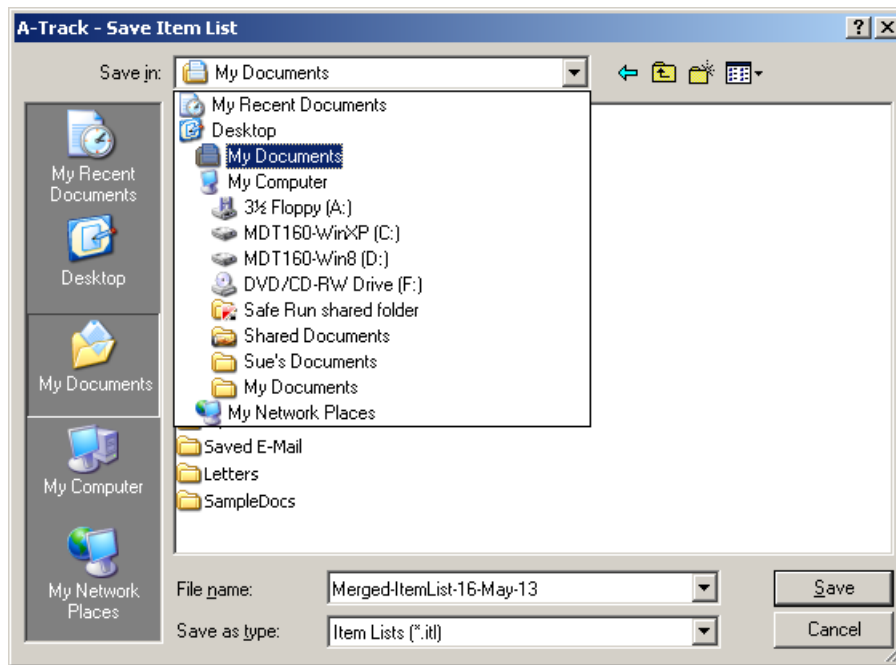

Double-click on the parent folder to open it, then use the **Create New Folder** button on the File Save window toolbar, as shown below. Type in a suitable name for the new folder, click **Open** to open it, then click again on the same button (now labelled **Save**) to save the Item List using either the suggested filename based on today's date, **Merged-Item-List-16-May-13** here, or one which is more meaningful to yourself, together with the **.ita** extension, selected from the **Save as type:** drop-down listbox –

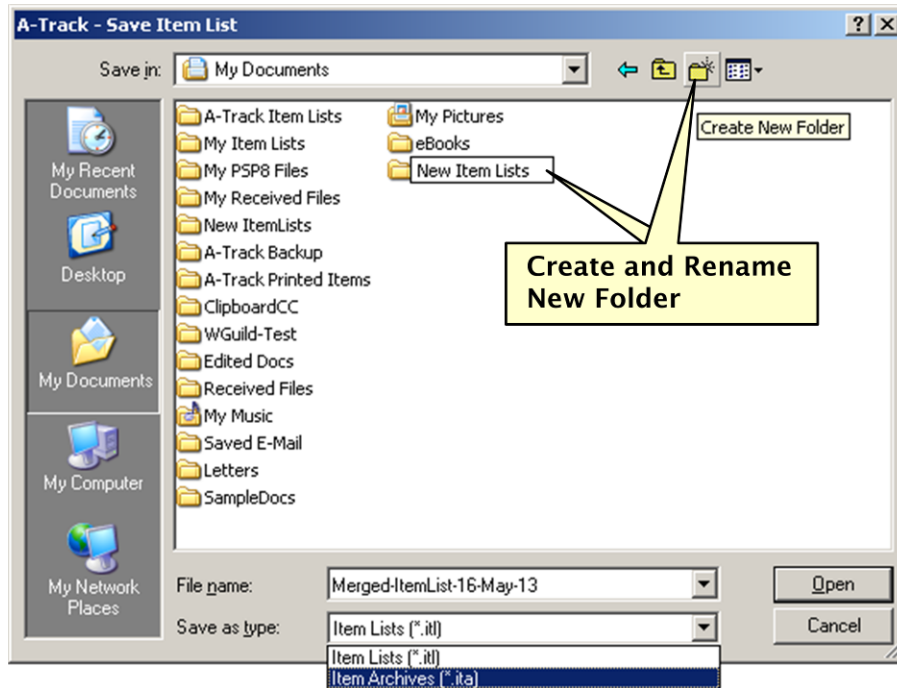

The format of the **Save Item List** dialog window in Windows Vista, 7, 8, and 10 is a little different, but the operations to create and rename a new folder are very similar, as are those to choose a filename and file extension, as shown in the Windows 10 example below –

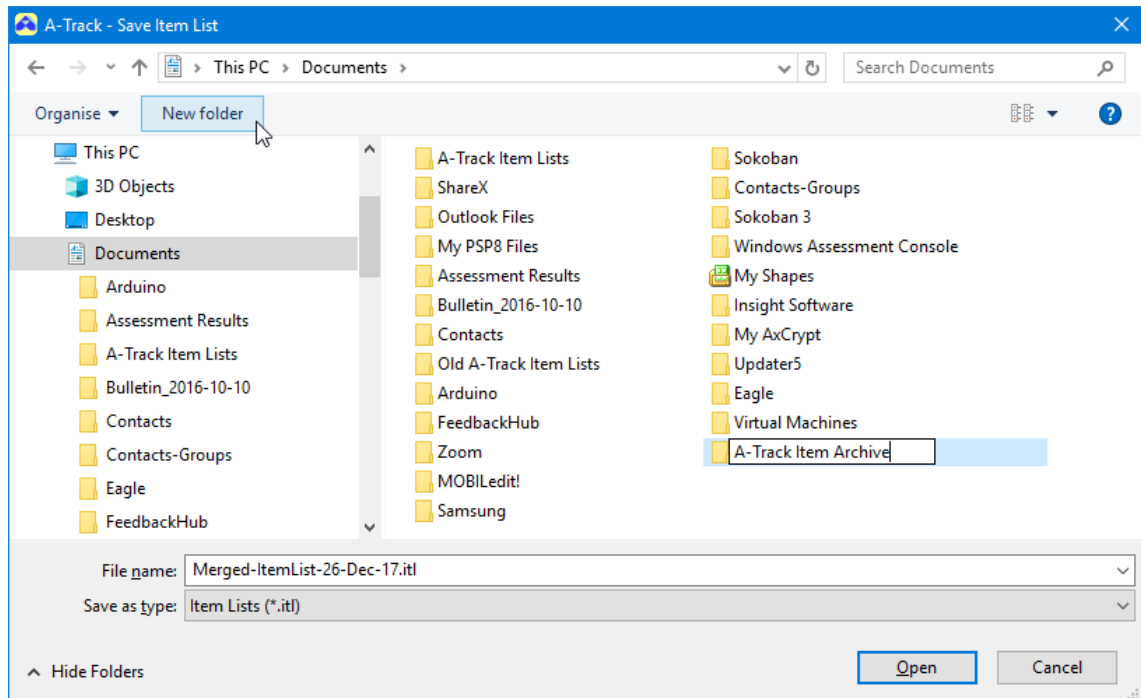

4.3 Other File and Program Functions

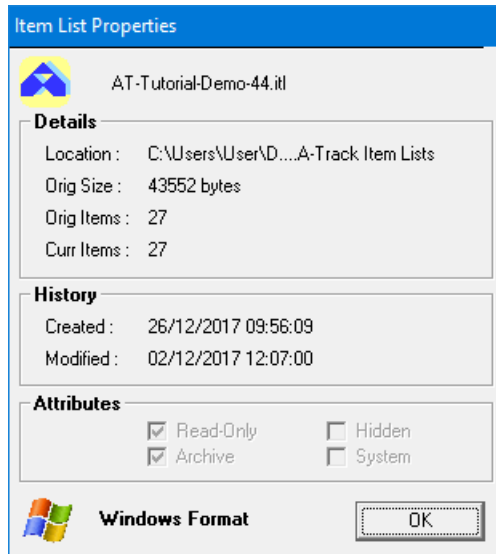

If for any reason you wish to check on details of the file in which the displayed Item List is held, click on **Properties** on the File menu –



The window shows details of the current Item List file, including the number of Items now in the List compared to the number when loaded.

Having loaded an Item List, you can use the **Print** function on the File menu (or the  icon on the Toolbar) to print out all or part of the displayed Item List, or the details of one or more individual Items selected from that Item List, either to paper or to a file which can be transferred to another computer for printing at a later time. Clicking on **Print** opens a new window in which the **Print Setup** option allows you to select a printer to use, and other options let you select the printer parameters and required output format. Details of the extensive Print facilities which are offered by A-Track are described fully in **Chapter 10** of this Reference Manual.

The final options on the File menu are **Close**, which simply terminates display of the currently open Item List, leaving the A-Track window empty, and **Exit**, which also closes any currently open Item List, removes it from display, and then terminates the A-Track program.

You can also terminate the program in the standard Windows fashion by clicking on the A-Track window Close button ( or  - top righthand corner of window).

Note : Because A-Track is in continual communication with the interface to the NCE Command Station, you may notice that there is a short pause, of a few seconds duration, before the program reacts to your closedown action, in order to allow this data traffic to be stopped in an orderly way.

With any of the terminate options, if the Item List has been changed in any way, you are asked whether you wish to save the current Item List before it is closed -

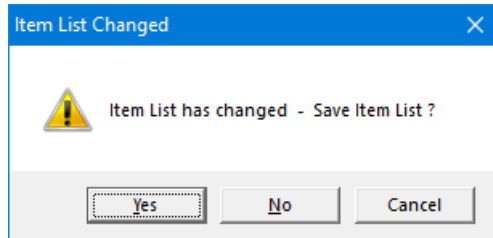

Selecting **Yes** allows you to save the changed Item List under your choice of filename, clicking **No** will immediately close the Item List and cause any changes to be discarded (permanently lost), while **Cancel** will abandon the Close or Exit process and return you to A-Track with the current Item List still displayed intact.

4.4 Editing - Undo, Redo, Find, and Selection

The Edit menu, shown below, allows you to alter the composition of the Item List by removing or adding Items, or by copying or moving Items to, or from, another Item List. During these manipulations the parameters of the Items themselves are not changed in any way, with some exceptions relating to Consists and Multiples (Locomotives assigned to Consists), as detailed in **Section 6.8**.

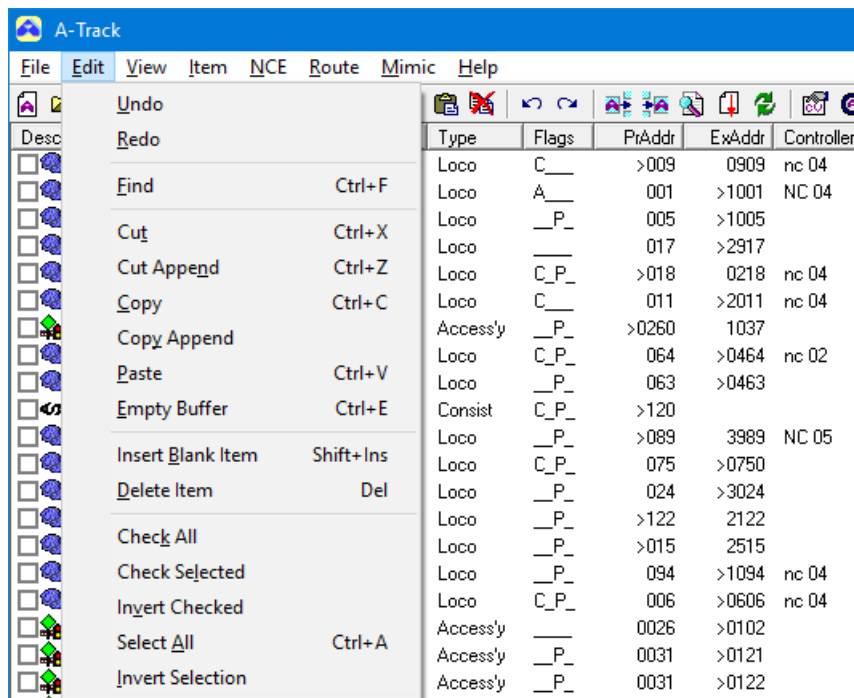

Any alterations which you choose to make to the Item List are not irrevocable, since A-Track incorporates an **Undo** facility which records the last 32 changes to the Item List and allows you to reverse them at any time. Once any action, or sequence of actions, has been 'undone', you then have the choice of performing some other operation on the restored Item List, or of reinstating some or all of the original sequence of changes by utilising the **Redo** facility. Toolbar icons are available for both Undo (↶) and Redo (↷) as an alternative to opening the Edit menu (see **Section 12.2** for full details).

As well as restoring the structure of the whole Item List, you can also employ the **Undo** function to reverse any changes that you have made to the parameters or Configuration Variables of individual Items through the facilities described later in **Chapter 5**. If, immediately after making alterations to an Item's parameters and evaluating its new characteristics on the track, you want to return the Item to its original state, then simply click Undo on the Edit menu, or the Undo icon on the toolbar. The edits made to the Item's parameters will then be 'undone', assuming that you have not made any other changes to the Item List in the meantime – if so, you will have to undo these subsequent changes before the desired Item is restored (and then make the subsequent changes to the Item List again, if necessary).

Note carefully, however, that restoring an Item's CVs to their original value in the Item List does **not** change the corresponding values in the real, physical DCC decoder in your locomotive or accessory. To do that, you will have to program (or re-program) the restored values into the actual decoder on the track, as explained in detail in **Section 6.7**.

The next function on the Edit menu, **Find** (also available through the  icon on the Toolbar) acts as an aid which allows you, particularly when dealing with large Item Lists, to search the complete Item List for particular Items. Click to display the **Find Item** window, then simply type any combination of letters or numbers that you believe are in the Description or Address (Primary or Extended) of the required Item(s) - your text will replace the prompt in the textbox –

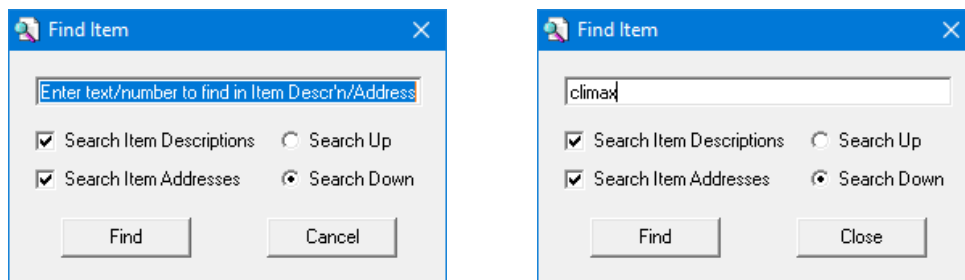

Select whether to search Item Descriptions or Addresses, or both (but selecting none will disable the Find operation), choose to search either Upwards (from the currently-selected Item towards the beginning of the Item List) or Downwards (from the current Item towards the end of the Item List), then click the **Find** button.

The first Item found whose Description or Address contains the entered search characters will then be highlighted in the Item List. Note, however, that if the currently highlighted Item matches the search criterion, then the Item highlight will not move – and you may think, incorrectly, that the Find operation has failed.

Click the **Next** button, as shown in the example below, to continue the search for the next Item (if any) which contains your search characters, or **Close** or **Finish** to terminate the Find operation, leaving the last found Item highlighted. If no further matching Items are found, then only the Finish button will be enabled to quit the operation (this will also be the case where no matching Items at all are located) –

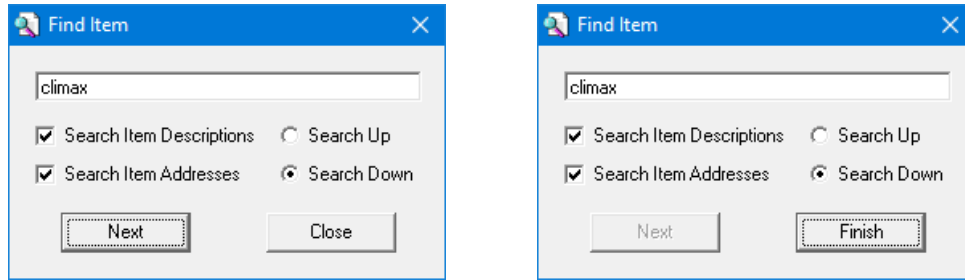

If you wish, you can move the Find Item window out of the way, so that it does not obscure any of the Item List details, by clicking on its title bar, holding down the left mouse button, and dragging the window to a convenient part of the screen. The Find Item window will remain on the screen, in front of the main A-Track window, until you click on the **Close** or **Finish** button, and does not interfere with any other A-Track or Item operations. Hence, having found a matching Item, you can examine its parameters in detail (see **Section 5.1**) to check if it is the Item you require, before resuming the search of the Item List.

At any point in using the Find Item function you can change any of the search parameters, or click on any Item in the Item List to define a new starting point for a revised search. After any such changes, click **Next** to restart the Find operation. Note that you can also do this by simply pressing the **Enter/Return** key – although be aware that, when the Finish button becomes active at the end of a search, the Enter/Return key will, instead, close the Find Item window.

The next group of options on the Edit menu, relating to **Cut**, **Copy**, and **Paste** operations, together with **Insert** and **Delete**, are dealt with fully in the following **Section 4.5**.

The remaining options provide some shortcuts when selecting Items for further operations such as saving, copying, or deletion.

Check All places a tick in the checkboxes located to the left of the Descriptions of all Items in the List, while **Check Selected** ticks the checkboxes of all Items which are currently selected, ie. highlighted, as described in **Section 4.5** below.

Invert Checked selects all checkboxes which were not already ticked and deselects all those which were ticked. Hence, if you wish to clear all checkboxes, apply Check All followed by Invert Checked. In another case, where you wish to check all Items except a few, it is quicker to tick all those that you do *not* want, then click Invert Checked to reverse the selection.

Select All simply highlights all of the Items in the displayed List, while the final option **Invert Selection** highlights those Items which were not highlighted before, and removes the highlight from all Items which were previously highlighted.

Hence to completely remove highlighting from all Items, apply Select All followed by Invert Selection. Note, however, that you can also remove multiple Item selections simply by clicking on any Item – although that single Item will remain highlighted. Where you want to select all Items except for a small number, it is quicker to select all those that you do *not* want, by holding down either of the **Ctrl** (Control) keys while clicking on those Items, then click Invert Selection to reverse the highlighting.



4.5 Editing - Cut, Copy, and Paste



To facilitate copying and moving Items between Item Lists, A-Track incorporates a private storage area known as the **Copy Buffer**. Copies of selected Items are moved into, and taken from, the Copy Buffer by using the **Cut**, **Copy**, and **Paste** operations on the Edit menu.



To select an Item which is to be the target of one of these Edit operations, click on it – the whole Item row is then highlighted. To select a group of Items, click on the first Item in the group, hold down either **Shift** () key, and click on the last Item in the group. Single Items can be added to a selected group (which may just be one other selected Item) by clicking on the Item to be added while either **Ctrl** (Control) key is held down. Conversely, clicking on a selected Item while holding down either **Ctrl** key will deselect that Item and remove its highlighting.

Once one or more Items have been selected, you can use either Cut or Copy to place copies of the selected Items in the Copy Buffer.

Note that, when any Edit CVs window is open, the whole Edit menu is disabled, together with the Delete Item, Cut, Cut Append, and Copy Append entries on the Pop-Up menu, and all of the relevant Toolbar icons. Hence, if you are unable to access the Item List Edit features, check first that all Edit CVs windows have been closed.

Cut (the  icon on the Toolbar) removes the selected Items from the Item List, ie. it **moves** the Items to the Buffer, where the moved Items *replace* any previous contents of the Copy Buffer. **Copy** () , on the other hand leaves the Items in the Item list, ie. it simply **copies** the Items, although the copied Items still *replace* any previous contents of the Copy Buffer.

If you wish to *add* selected Items, or copies of the selected Items, to the Items which are already in the Copy Buffer, then use either **Cut Append** () or **Copy Append** () . These operations work in essentially the same way as Cut and Copy, respectively, but the Items moved or copied are *added* to any previous contents of the Copy Buffer, instead of replacing or overwriting them. This allows you to select the Items you wish to copy or transfer in several stages rather than attempting to perform the operation in a single step.

When you have all of the required Items in the Copy Buffer, you then use **Paste** () to place all of the copied Items back into an Item List. The copied Items are added to the end of the current Item List file being displayed by A-Track **unless** you have chosen to **sort** the Item list by one of the Item parameters, in which case they will be inserted at an appropriate position in the List determined by the sort order. This can cause you to lose track of some of the copied Items when pasting in a sizeable group of Items, so that you are recommended to sort the Item List by **File Order** (either via the View / Arrange Items menu, or the  icon on the Toolbar) before (or after) executing the Paste operation. The pasted Items can then all be found together at the end (bottom) of the List.

If you Paste the Items back into the same Item List as they were taken from, then you will have a set of duplicated Items. While this is perfectly allowable (and A-Track treats such duplicates as different Items even though their parameters are identical) it can lead to problems subsequently, when you are never going to be sure which duplicate Item is the one to be edited or controlled. Hence, the recommendation is to change at least the Address of each duplicate Item immediately – and preferably their Descriptions also – to eliminate any confusion.

Creating duplicate Items is a useful shortcut when you are adding a new Item to your roster which is very similar to one that you already have there, and can save a lot of time in setting up all of the Configuration Variables (CVs) and other parameters for the new Item.

Important Note : When using Cut, Copy, and Paste operations on Items which are either **Consists** or **Multiples** (Locomotives assigned to a Consist) you need to be aware that the links within and between such Items require them to be handled in a special way –

- When you Cut or Copy a **Multiple**, the Item placed in the Copy Buffer is changed to a **Locomotive** with exactly the same parameters, but which is no longer linked to the Consist, and it will be Pasted back into the Item List as a Locomotive.
- When you Copy a **Consist**, the assignments of Locomotives (Multiples) to the copied Item are cleared, so that, if you Paste the copy back into the Item List, it will appear as a **blank** Consist with the same address as the original, but without any assigned Locomotives.
- If you Cut a **Consist** then, as well as being placed in the Copy Buffer without any assignments, all **Multiples** which were assigned to the Consist are also deleted from the Item List, but immediately pasted back as **Locomotives** with the same parameters as the original Multiples. Pasting the cut Consist back into the Item List again results in a **blank** Consist without any of its original assignments. Further details on the handling of Consists and Multiples can be found in **Sections 6.11** and **6.12**.

If you do wish to **transfer a complete Consist** with its assigned Multiples to another Item List, then you should **check** each of the group of Items (Consist plus Multiples) by clicking in the checkbox at the beginning of each Item row, leaving a tick in each checkbox. Then, from the **File** menu, select **Save Checked** to save the Consist and its group of Multiples as a small, standalone Item List with an appropriate filename.

Next, close the current Item List (saving it if necessary), and **Open** the Item List into which you wish to place the saved Consist. Once this Item List has loaded, click **Open Merge** from the **File** menu, then locate and select the small Item List containing the Consist. A final click on Open in the Merge Item List window will add the Consist to the second Item List as desired.

If you make a mistake when using Cut, Copy, or Paste remember that you can easily put the Item List back to the state it was in previously by using the **Undo** function described in **Section 4.4** – always bearing in mind that Undo only records the last 32 Edit actions performed on the Item List (although each Edit action can include any number of Items).

With a selected set of Items in the Copy Buffer, you can transfer them to either another existing Item List, or you can create a new Item List to hold them. Do this either by clicking on File / Open to open an existing List, or on File / New to create a new Item List with one Blank Item, and in either case saving the current Item List if necessary, when prompted.

The contents of the Copy Buffer are then added to the newly-displayed Item List by clicking **Paste**. A typical sequence of actions is shown below for the case of a completely new Item List.

First, select and **Copy** (or **Cut**) a set of Items –

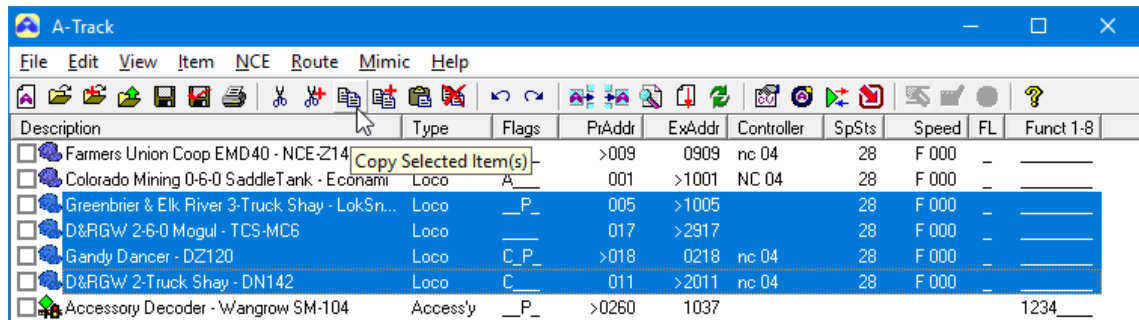

Next, close the Item List (using File/Close), dealing appropriately with any prompt to save the List if it has been changed, then open a new List with one Blank Item (using File/New), and click Paste –

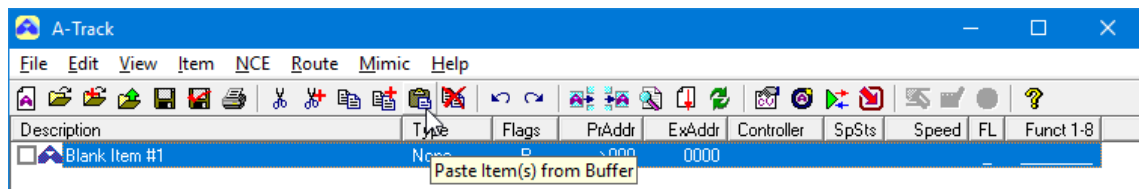

- to add the copied (or cut) Items from the Copy Buffer to the new Item List –

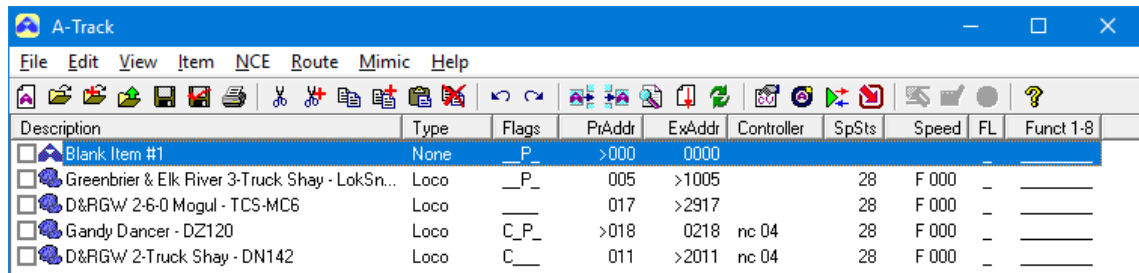

The Blank Item can either be converted into a valid Item in its own right (see **Section 5.3**), or simply removed by using either **Delete** from the Edit menu, or the  icon on the Toolbar, or just by pressing the Delete key on the keyboard, with the Blank Item highlighted (as above).

Important : using the **Delete** operation does *not* copy any deleted Items to the Copy Buffer, although you can restore such Items using Undo if they were deleted in error.

Note, however, that if you Delete a Consist, then any assigned Multiples are also deleted, but immediately converted to Locomotives, as explained previously, and then pasted back into the Item List.

Copied Items remain in the Copy Buffer until replaced by another Cut or Copy operation or removed by the remaining operation involved in handling the Copy Buffer, namely, **Empty Buffer** (). This Edit operation, as is fairly obvious, completely clears all copied Items from the Buffer.

Note carefully that the Empty Buffer action can *neither be reversed nor undone* - so that any Items which were Cut or Copied to the Buffer will be completely lost (the original Copied Items will still be in the Item List, of course, provided you have not

Deleted them in the meantime). A warning to this effect is displayed, asking you to confirm the deletion –

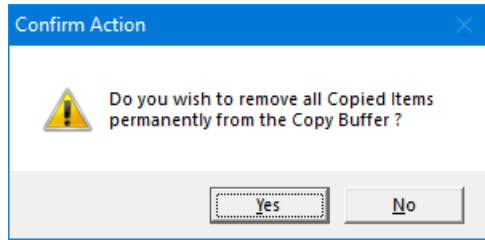

After clearing the Copy Buffer, you may still be able to perform a set of Undo operations to regain any Cut Items, provided the Cut operation(s) occurred within the last 32 Edit actions (and, of course, you should have a back-up copy of the original Item List stored safely on your hard disk or removable media). However, in any case, to restore the Copy Buffer contents, you will have to copy the relevant Items again.

To add a new Item to the displayed Item List, use **Insert Blank Item** on the Edit menu, or the  icon on the Toolbar –

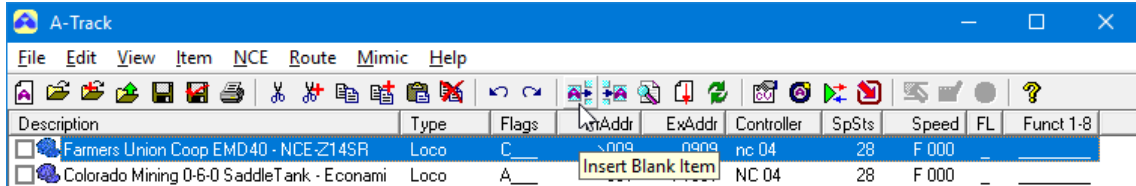

Either action adds a Blank Item to the end of the Item List, although the position at which it is displayed on the screen will depend on how the Item List is currently sorted (see **Section 4.1**). Each Blank Item which is added has a unique identifying number added to its Description field (#28 in the example below) to help you when accessing and editing a specific Item's parameters after adding several Blank Items to the List –

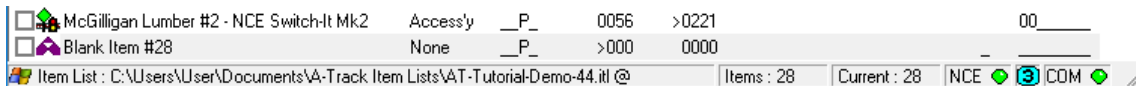

Note that adding further Blank Items by copying the first Blank Item, and then pasting it into the Item List, results in all new Blank Items displaying the same identification number – although A-Track will still handle them all as unique Items using an assigned internal key.

After inserting a Blank Item you need to set up its parameters to change it into an Item which corresponds to one of the real locomotives, consists, or accessories to be operated on your track layout. How to do this for all types of Items and their range of possible functions is explained fully in **Chapter 5**.

5 GENERAL ITEM OPERATIONS

The characteristics of each Item in the Item List are set primarily by the values of the Configuration Variables (CVs) which are programmed into the real DCC decoder fitted within the locomotive or accessory corresponding to the Item.

You can obtain access, to set and modify the Item's CVs, together with the various other parameters which provide a full Item definition, through either the **Item** or **Pop-Up** menus (refer to **Chapter 12** for descriptions of all menu operations).

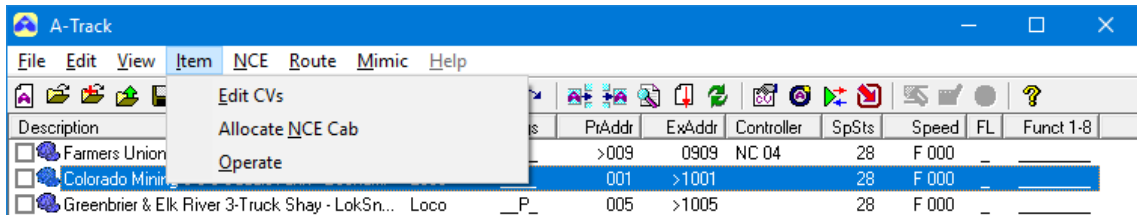

The **Pop-Up** menu appears whenever an Item is **right-clicked**. The Pop-Up menu also contains selected options from the Edit menu for convenience (but note that, here, the functions apply *only* to the single Item which was right-clicked) -

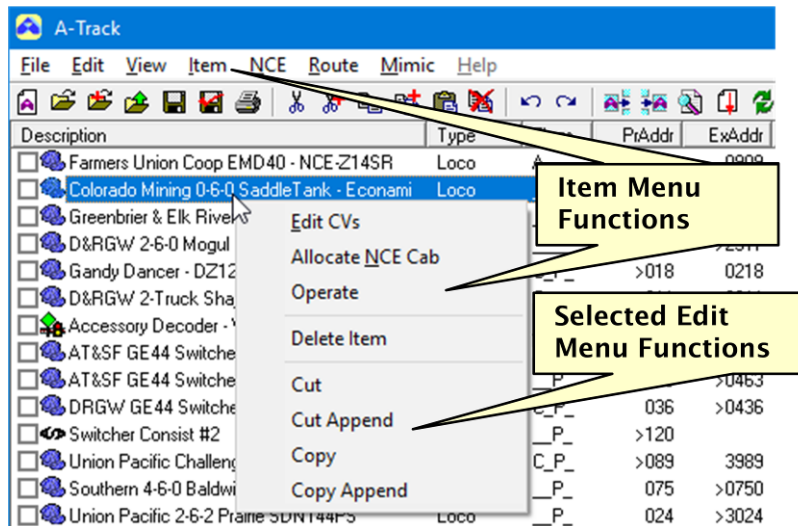

Clicking the **Edit CVs** entry on the Item or Pop-Up menu will open a new window which allows all of the Item's Configuration Variables and other parameters to be viewed, edited, and programmed into the real Item's DCC decoder.

While the CVs of any Item are being edited, you *cannot change or edit the Item List*. All relevant File menu options, such as New, Open, and Close, and the complete Edit menu, are disabled until you close all editing windows.

5.1 Edit Configuration Variables Window

Click on **Edit CVs** in either menu, or on the  icon on the toolbar (see above), or simply **double-click** on the Item itself in the Item List to open the Edit Configuration Variables window for the selected Item -

Item #6 - Addr 2011 - Configuration Variables

Item Description: D&RGW 2-Truck Shay - DN142

Program CVs
Read/Verify CVs
Copy All CVs
Paste Main CVs
Paste Exten'd CVs
Paste Index'd CVs
Update Item
Close

Identity Config Speed Funct'n Pages SUSI

Item Type: Locomotive

Primary Address: 011
Extended Address: 2011
Consist Address: 000
User Identifier #1: 000
User Identifier #2: 000
Manufacture Version No.: 250
Manufacture: 129

Active - N/Cab: 02 Edited: No

CV	0x	1x	2x	3x	4x	5x	6x	7x	8x	9x	10x	11x	12x
0	000	000	000	000	000	000	000	064	180	240	000	000	000
1	011	000	000	000	000	000	000	078	188	244	000	000	000
2	000	001	000	000	000	000	000	092	196	248	000	000	000
3	000	000	000	000	000	000	000	106	204	252	000	000	000
4	000	000	000	000	000	000	128	118	210	255	000	000	000
5	000	000	000	000	000	128	001	130	216	000	000	000	000
6	000	000	000	000	000	048	000	142	222	000	000	000	032
7	250	199	000	000	000	000	016	152	228	000	000	000	000
8	129	219	000	000	000	000	032	162	232	000	000	000	000
9	000	000	054	000	000	000	048	172	236	000	000	000	000

Note that you can open Edit CVs windows for as many Items as you wish at the same time, and work with any selected window, including the main A-Track window, while all Edit CVs windows remain on the screen. The windows can be minimised to the Task Bar, to reduce screen clutter, if required. If you have several Edit CVs windows open then, in order to see them all on the screen at the same time, make sure that the main A-Track window is not maximised – otherwise you will only see one Edit CVs window displayed on the screen (in front of the maximised A-Track window) at a time.

An Edit CVs window has four distinct areas, each containing some information or parameters relating to the corresponding Item -

- **Item Description** - a piece of descriptive text about the Item - this can be anything you wish, up to a maximum length of 64 characters
- **Parameter Tabs** - a collection of tabs or pages each dealing with a set of related Item CVs or other parameters
- **Action Buttons** - to invoke functions related to editing CVs, transferring them between Items and DCC decoders, and saving the results back to the Item List
- **CV Values** - a grid showing the value held in the Item for each Configuration Variable. A CV value can lie between 000 and 255, although valid values for specific CVs can be restricted to a smaller range by the NMRA standards or by the decoder manufacturer. When opened initially, as above, the grid shows CV01 to CV128, but other ranges of CV values can be displayed when required (see **Section 6.3**).

When you pause the mouse cursor over any CV value in the grid, a pop-up label describing the function (if any) allocated to that CV will be displayed, as

shown in the example below, where the cursor is over CV01 which holds the Item's Primary Address –

CV	0x	1x	2x	3x	4x	5x	6x	7x	8x	9x	10x	11x	12x
0	000	000	000	000	000	000	000	064	180	240	000	000	000
1	011	000	000	000	000	000	000	078	188	244	000	000	000
2	000	001	000	000	000	000	000	092	196	248	000	000	000
3	000	000	000	000	000	000	000	106	204	252	000	000	000
4	000	000	000	000	000	000	128	118	210	255	000	000	000

The Edit CVs window opens showing the **Item Description** and the contents of the **Identity** Parameter Tab, as shown on the previous page. This Tab displays the Type of Item (Locomotive, in this case), and allows you to set or change the Item's Primary and Extended Addresses for a Locomotive, the Primary Address for an Accessory, or Consist Address if the Item is a Consist or Multiple, and to enter your own values for the User Identifiers if required.

5.2 Setting Key Item Parameters

The **Item Type** and **Primary** (or **Consist**) **Address**, at least, must be defined under the Identity Parameter Tab before the Item becomes usable (and it is always advisable to enter a sensible Item Description, possibly with details of the fitted decoder and, in a club roster, the owner's name or initials, before proceeding).

The Identity Tab also shows the current **allocation** of a Loco or Consist Item to either an NCE Cab (only if you are using an NCE Power Pro or Power Cab / Smart Booster V1.65 system) or to a Console (under direct control from the PC screen). When allocated to an NCE Cab as the current Item under control, the relevant Cab Address is shown (02 here), together with a **green/white tick** icon (✔) –

CV	0x	1x	2x	3x	4x	5x	6x	7x	8x	9x	10x	11x	12x
0	000	000	000	000	000	000	000	064	180	240	000	000	000

Alternatively, if a Loco or Consist Item is held in the NCE Cab Recall List (not under active control), the alternative **yellow/green tick** icon (✔) is used –

CV	0x	1x	2x	3x	4x	5x	6x	7x	8x	9x	10x	11x	12x
0	000	000	000	000	000	000	000	064	180	240	000	000	000

Note that Accessory Items cannot be allocated to an NCE Cab although, like Loco and Consist Items, they can be allocated to direct control through the PC screen and mouse, ie. to a Console. This is indicated with a **green/white tick** icon (✔) on the Identity Tab, together with display of the corresponding Console address – '01' in the example shown below –

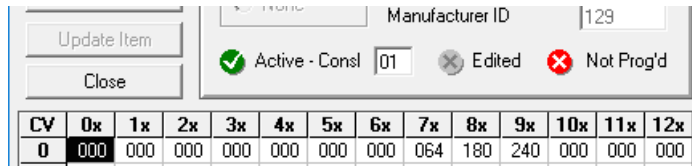

Besides an identifying Address, the other key parameter for **Locomotive** (or **Multiple**) Items which must be defined before using the Item with a real decoder is the **Decoder Configuration**, held in Configuration Variable CV29, whose current settings can be found under the **Config** Parameter Tab. Click on **Config** to reveal the tab's contents, as shown below for a Loco Item –

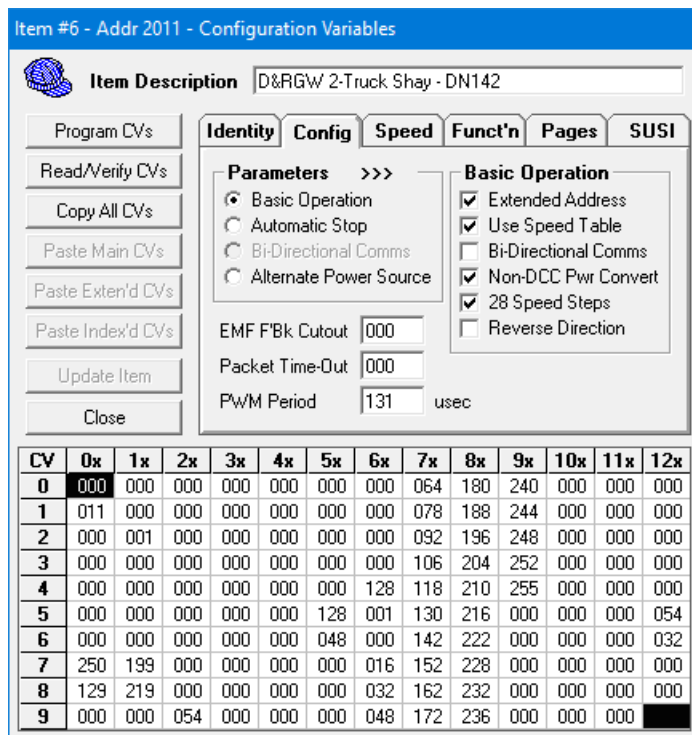

You can enter the basic settings required for CV29 simply by clicking on the group of checkboxes shown under **Basic Operation**, which will select (tick) the required set of options for this Item. With the options set as above, the Locomotive will respond to its Extended Address (4-digit value) and will use the Speed Table defined by the 28 values in CV67 to CV94 (see **Section 6.1** for guidance in defining and using Speed Tables).

When any of the checkboxes are ticked, A-Track will automatically translate the selection into the appropriate value held in the relevant Configuration Variable (CV).

If the Locomotive is to be used on a non-DCC system then the **Non-DCC Pwr Convert** option is ticked as shown. You can then click on the **Alternate Power Source** option button in the **Parameters** section to view a set of six alternative systems which can be selected –

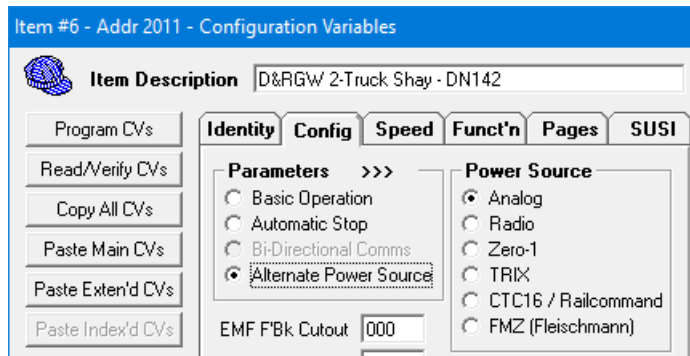

Operation on DC (**Analog**) – as opposed to DCC – is selected automatically as the default option, and results in the value of CV12 being set to 001 (as shown above).

More complex configuration parameters can be accessed by selecting one of the other sets listed under **Parameters**. If the decoder being used supports the facility (consult the manufacturer’s user documentation for details), **Automatic Stop** provides a means of bringing the Locomotive to a halt when it encounters a specific condition on the track, as selected from the available options –

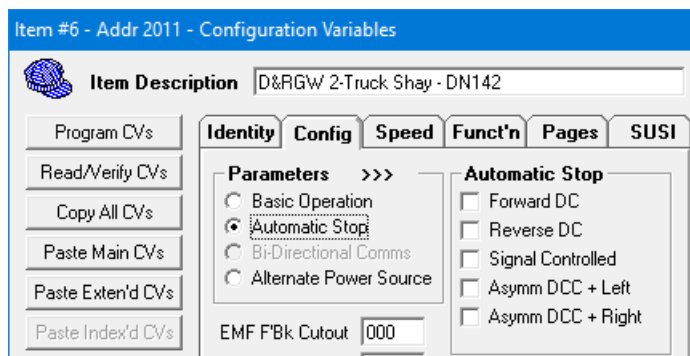

If the **Bi-Directional Comms** option is ticked under **Basic Operation**, and the decoder being used supports this type of facility (consult the manufacturer’s user documentation for details), clicking the **Bi-Directional Comms** option button in **Parameters** will then display three possible types of communication from the decoder back to the Command Station –

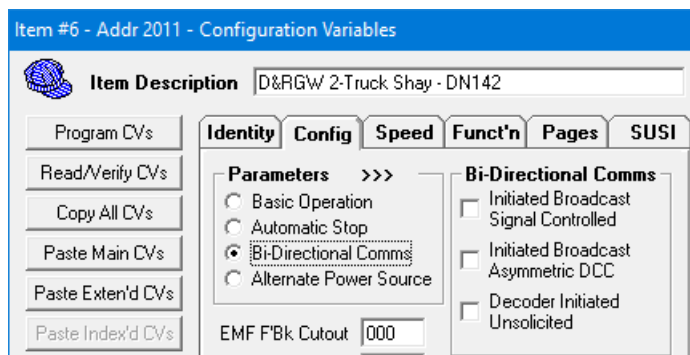

Note that, although several decoder manufacturers have implemented their own proprietary bi-directional communications systems, it would appear that no one has yet offered a system which complies with the NMRA specification.

In addition to these esoteric options, under the Config Tab you can also set more normally-encountered parameters such as the EMF Feedback Cutout, Packet Time-Out, and PWM Period, although it is probably best to leave these alone unless you have some guidance on recommended values from the decoder or locomotive manufacturer. Note that the PWM Period value is defined (in the NMRA Standards and Recommended Practices) by a rather complex formula which, while allowing a wide range of values, restricts these values to specific numbers. Hence, if you type a new value into the PWM Period textbox, your entry will be converted to the nearest allowed value less than your entered figure. Allowed values range from 131 to 32640 microseconds (usec).

For an **Accessory** Item, the format of the **Config** Tab has fewer options, as shown in the example below. The basic **Parameters**, as defined in the NMRA DCC Standards, are simpler, where the only other configuration options allow you to select which of the four pairs of Auxiliary inputs will operate the corresponding pair of Accessory outputs, and the time for which each pair of outputs will stay in the 'On' state following receipt of an activating command to the relevant Output Address (shown highlighted with a **light yellow** background) –

CV	0x	1x	2x	3x	4x	5x	6x	7x	8x	9x	10x	11x	12x
0	000	255	255	255	000	000	000	000	000	000	000	000	000
1	004	255	255	255	000	000	000	000	000	000	000	000	000
2	214	255	255	255	000	000	000	000	000	000	000	000	000
3	000	255	255	000	000	000	000	000	000	000	000	000	000
4	000	255	255	000	000	000	000	000	000	000	000	000	000
5	000	000	255	000	000	000	000	000	000	000	000	000	000
6	000	000	255	000	000	000	000	000	000	000	000	000	000
7	012	255	255	000	000	000	000	000	000	000	000	000	000
8	012	255	255	000	000	000	000	000	000	000	000	000	000
9	004	255	128	000	000	000	000	000	000	000	000	000	000

Although the NMRA DCC Standards generally assume that Accessory decoders (like those for Locomotives or Consists) will have their address, at least, programmed on a separate Program Track, most manufacturers now produce Accessory decoders which are designed to have their addresses, and any other parameters, programmed directly from the Mainline Track in conjunction with switch or special wiring settings on the decoder itself, and it is rare nowadays for an Accessory decoder manufacturer to use

any CVs to control the decoder's operation. Refer to the decoder manufacturer's user documentation for details of their specific control scheme.

When you set up an Item to represent one of these modern Accessories, you should click to tick the checkbox in the **Programming** area (see above) labelled **Program on Main Track (Manuf Specific)**. If this is an Accessory decoder manufactured by NCE, then tick the **NCE** checkbox as well – and the **Mark 2** checkbox if it is one of NCE's more recent products.

Two further Parameter Tabs labelled **Addr**s and **Names** will then be displayed, and will allow you to allocate up to eight **Output Addresses** to the Accessory, together with several other options, and then to give each Output Address a descriptive **Name** which is representative, perhaps, of the layout location of a turnout to be controlled via that address. An example is shown below for an NCE Switch-It –

Item #26 - Addr 0212 - Configuration Variables

Item Description: McGilligan Lumber #1 - NCE Switch-It

Program CVs
Read/Verify CVs
Copy All CVs
Paste Main CVs
Paste Exten'd CVs
Paste Index'd CVs
Update Item
Close

Identity **Config** **Addr**s **Names**

Number of Outputs: 2
Program Acc's'y
 Sequential Addresses

NCE Options
 Enable O/P Toggle
 No Legacy Ops Prog
 Disable P-Button I/Ps
 Enable O/P Exercise
 Rev Output Polarity

Output Address --- Sel

Output 1	0211	<input type="radio"/>
Output 2	0212	<input checked="" type="radio"/>
Output 3	=====	<input type="radio"/>
Output 4	=====	<input type="radio"/>
Output 5	=====	<input type="radio"/>
Output 6	=====	<input type="radio"/>
Output 7	=====	<input type="radio"/>
Output 8	=====	<input type="radio"/>

CV	0x	1x	2x	3x	4x	5x	6x	7x	8x	9x	10x	11x	12x
0	000	000	000	000	000	000	000	000	000	000	000	000	000
1	053	000	000	000	000	000	000	000	000	000	000	000	000
2	000	000	000	000	001	000	000	000	000	000	000	000	000
3	000	000	000	000	000	000	000	000	000	000	000	000	000
4	000	000	000	000	000	000	000	000	000	000	000	000	000
5	000	000	000	001	000	000	000	000	000	000	000	000	000
6	000	000	000	000	000	000	000	000	000	000	000	000	000
7	000	000	000	000	000	000	000	000	000	000	000	000	000
8	000	000	000	000	000	000	000	000	000	000	000	000	000
9	000	000	192	000	000	000	000	000	000	000	000	000	000

Item #26 - Addr 0212 - Configuration Variables

Item Description: McGilligan Lumber #1 - NCE Switch-It

Program CVs
Read/Verify CVs
Copy All CVs
Paste Main CVs
Paste Exten'd CVs
Paste Index'd CVs
Update Item
Close

Identity **Config** **Addr**s **Names**

Addr-Link+Dir+Name	Output (Turnout) Name
1 0211 0000 U <input type="checkbox"/>	1 McGilligan #1 East
2 0212 0000 U <input type="checkbox"/>	2 McGilligan #1 West
3 ===== = <input type="checkbox"/>	3
4 ===== = <input type="checkbox"/>	4
5 ===== = <input type="checkbox"/>	5
6 ===== = <input type="checkbox"/>	6
7 ===== = <input type="checkbox"/>	7
8 ===== = <input type="checkbox"/>	8

CV	0x	1x	2x	3x	4x	5x	6x	7x	8x	9x	10x	11x	12x
0	000	000	000	000	000	000	000	000	000	000	000	000	000
1	053	000	000	000	000	000	000	000	000	000	000	000	000
2	000	000	000	000	001	000	000	000	000	000	000	000	000
3	000	000	000	000	000	000	000	000	000	000	000	000	000
4	000	000	000	000	000	000	000	000	000	000	000	000	000
5	000	000	000	001	000	000	000	000	000	000	000	000	000
6	000	000	000	000	000	000	000	000	000	000	000	000	000
7	000	000	000	000	000	000	000	000	000	000	000	000	000
8	000	000	000	000	000	000	000	000	000	000	000	000	000
9	000	000	192	000	000	000	000	000	000	000	000	000	000

Further details of how to set up addresses, names, and parameters for Accessory Items, and then program the relevant values into the actual decoder, can be found in **Sections 7.1, 7.3, and 7.5.**

The Edit CVs window for a **Consist** Item does not use any Parameter Tabs other than **Identity** and **Config**, since the detailed parameters for the Consist's constituent Locomotives (referred to as Multiples) are stored in the Multiple Items themselves.

The **Consist Config** Tab shows you, in a drop-down list, which Locomotives are currently assigned to this Consist, together with controls to alter the Locomotive assignments to suit your requirements. Note, however, that a Consist Item does not possess any real Configuration Variables of its own, and that you cannot directly edit any of the values shown in the CV Value Grid (some of which are used by A-Track to save details of the Consist) –

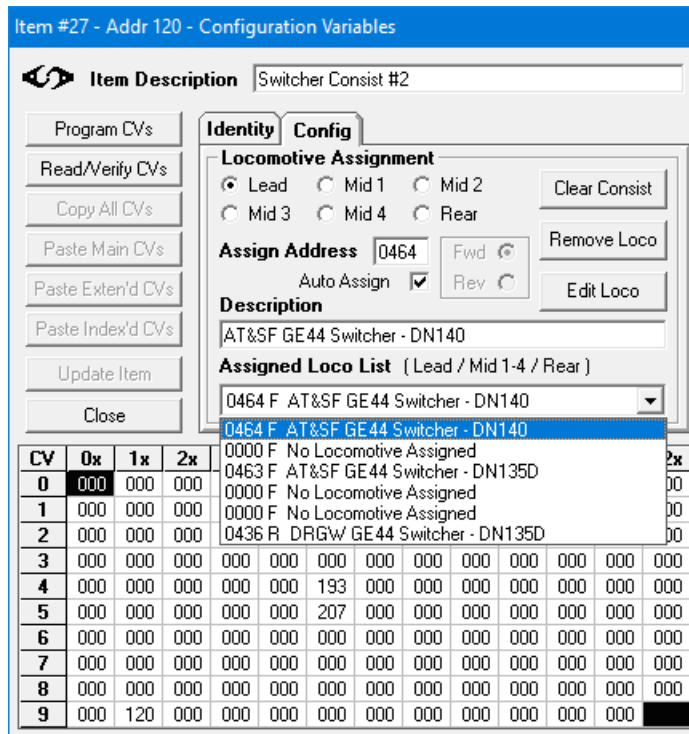

By selecting any of the assigned Locomotives listed under the Config Tab, and then clicking the **Edit Loco** button, you can open a new Edit CVs window displaying the parameters of the selected locomotive. If you open Edit CVs windows for all of the assigned locomotives then you can check that all of their individual parameters are consistent with each other.

In particular, ensure, under the Speed Parameter Tab, that each Locomotive uses the same Speed Step Precision (14, 28, or 128) and that their speed characteristics are matched. Matching speed characteristics, so that each locomotive runs at the same track speed for any given speed controller setting may require implementation and tailoring of one of the Speed Tables for each locomotive individually (even if they are nominally the same model from the same manufacturer). See **Section 6.1** for details of Speed Table settings, and **Sections 6.11 to 6.13** for full details of how Consists are constructed and handled.

Feel free to explore all of the options available in the Edit CVs window and experiment with changing the various CV options. You cannot do any damage to the Item's actual stored values because, in the Edit CVs window, you are only working with a temporary copy of each Item's parameters.

As soon as you make any change to the Item's parameters or CV values, the **Update Item** Action Button will be enabled, as shown above.

When the **Update Item** button is clicked, all edits will be transferred immediately to the Item in the Item List, replacing all previous parameter values. Even then, after updating an Item's parameters, the Item List **Undo** option is still available to return the Item to its former state and, if all else fails, you can choose not to save the altered Item List when you close the A-Track program, leaving you (hopefully) with a safely-stored copy of the original Item List.

Alternatively, when you click on the **Close** Action Button, after making any changes to the Item's parameters, you will be presented with a set of options either to transfer the changed values to the Item proper in the Item List (**Yes**), or to ignore all changes (**No**), leaving the Item in its original state, or to return to the Edit CVs window in its current state (**Cancel**), allowing you to continue with editing –

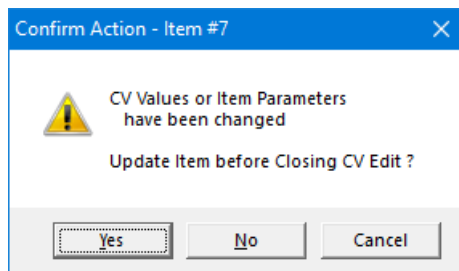

If no changes have been made to the Item's parameters, clicking Close simply closes the Edit CVs window.

5.3 Initialising a Blank Item

Before looking at the other Parameter Tabs, it is worth going through the initial actions you need to perform under the Identity and Config Tabs when adding a new Item to the Item List, ie. starting with a Blank Item inserted using the Edit action described at the end of **Section 4.5**. Part of this process was previously covered in **Section 3.7** as a quick, practical introduction to the usage of A-Track.

A double-click on the Blank Item opens an Edit CVs window as usual, but showing all Item parameters with zero values.

Your first action must be to select the **Item Type** - the available choices are Accessory, Consist, and Locomotive, as shown below. You cannot proceed to define any other parameters while the Item Type remains at **None**. Your selection will change the **Item Description** appropriately, and highlight it in **pink**, indicating that it has been changed since the Edit CVs window was opened. Note that once you have selected an Item Type you cannot change it to another Type – if you select the wrong Type by mistake, simply click Close, select No when prompted to update the Item, then double-click on the original Blank Item to re-open it in a fresh Edit CVs window.

Item #28 - Addr 000 - Configuration Variables

Item Description Blank Item #28

Program CVs
Read/Verify CVs
Copy All CVs
Paste Main CVs
Paste Exten'd CVs
Paste Index'd CVs
Update Item
Close

Identity **Config** Speed Funct'n Pages SUSI

Item Type
 Accessory
 Consist
 Locomotive
 Multiple
 None

Primary Address 000
 Extended Address 0000
 Consist Address 000 - 127
 User Identifier #1 000
 User Identifier #2 000
 Manufac Version No. 000
 Manufacturer ID 000

Not Allocated 00 Edited Not Prog'd

CV	0x	1x	2x	3x	4x	5x	6x	7x	8x	9x	10x	11x	12x
0	000	000	000	000	000	000	000	000	000	000	000	000	000
1	000	000	000	000	000	000	000	000	000	000	000	000	000
2	000	000	000	000	000	000	000	000	000	000	000	000	000
3	000	000	000	000	000	000	000	000	000	000	000	000	000
4	000	000	000	000	000	000	000	000	000	000	000	000	000
5	000	000	000	000	000	000	000	000	000	000	000	000	000
6	000	000	000	000	000	000	000	000	000	000	000	000	000
7	000	000	000	000	000	000	000	000	000	000	000	000	000
8	000	000	000	000	000	000	000	000	000	000	000	000	000
9	000	000	000	000	000	000	000	000	000	000	000	000	000

Assume that we select **Locomotive**, so that the Description becomes "Blank Locomotive #28", together with an icon appropriate to a Locomotive (🚂 - see **Section 4.1**), as shown below -

Item #28 - Addr 000 - Configuration Variables

 **Item Description** Blank Locomotive #28

Program CVs
Read/Verify CVs
Copy All CVs
Paste Main CVs
Paste Exten'd CVs
Paste Index'd CVs
Update Item
Close

Identity **Config** Speed Funct'n Pages SUSI

Item Type
 Accessory
 Consist
 Locomotive
 Multiple
 None

Primary Address 003
 Extended Address 0003
 Consist Address 000
 User Identifier #1 000
 User Identifier #2 000
 Manufac Version No. 000
 Manufacturer ID 000

Not Allocated 00 Edited Not Prog'd

Select Item Type

CV	0x	1x	2x	3x	4x	5x	6x	7x	8x	9x	10x	11x	12x
0	000	000	000	000	000	000	000	000	000	000	000	000	000
1	003	000	000	000	000	000	000	000	000	000	000	000	000
2	000	000	000	000	000	000	000	000	000	000	000	000	000
3	000	000	000	000	000	000	000	000	000	000	000	000	000
4	000	000	000	000	000	000	000	000	000	000	000	000	000
5	000	000	000	000	000	000	000	000	000	000	000	000	000
6	000	000	000	000	000	000	000	000	000	000	000	000	000
7	000	192	000	000	000	000	000	000	000	000	000	000	000
8	000	003	000	000	000	000	000	000	000	000	000	000	000
9	000	000	002	000	000	000	000	000	000	000	000	000	000

Note that CV01, CV17, CV18, and CV29 in the CV Value Grid are also highlighted in **pink**, and that the value of CV01 has been changed to 03 which is the default **Primary Address** for Locomotive decoders. The entries for CV17 and CV18, which together hold the **Extended Address** for a Locomotive decoder, also represent a value of 0003 since, as required by the NMRA DCC standards, CV17 always has a hexadecimal value of C0 (192 decimal) added to it.

The updated **Configuration** value in CV29 (02), indicates that 28 Speed Steps operation has been selected.

If the new Item's Type is selected as **Accessory**, then the default **Accessory Address** value of 01 will be stored in two parts in CV01 (01) and CV09 (00), and the Configuration value in CV29 will be set to 80 hexadecimal (128 decimal) to indicate an Accessory Decoder. Further details on setting up a new Accessory can be found in **Sections 7.1** and **7.3**.

Conversely, if **Consist** is selected for the Item Type, then the **Consist Address** held in CV19 will be set to the first available consist address. Consist addresses can range from 01 up to 127 and, to be consistent with the policy applied by NCE Power Pro and Power Cab Systems, address allocation starts at 127 and works downwards until an address unused by any other Consist in the current Item List, or held within the NCE Command Station (if it has been connected), is found. If all possible addresses have already been allocated, then a warning is displayed and the creation of a new Consist is terminated. Further details on setting up a new Consist are covered in **Section 6.11**.

Continuing with the initialisation of our example Locomotive, the next step is to click in the **Item Description** textbox (to the right of "Blank Locomotive #28") ready to enter a suitable title for the Item. With "Blank Locomotive #28" highlighted, simply type a new descriptive title for the Item, of up to 64 characters, then press the **Enter/Return** or **Tab** () key. The new Item Description remains highlighted in pink to show that it has been changed.

Now, click on the **Pages** Parameter Tab where, in the **Decoder Manufacturer** section, you should click the **Specific Manufacturer** option button followed by a click on the down-arrow () at the righthand end of the listbox below the option button. Full details of the Pages Tab options are described later in **Section 6.3**.

If the make of decoder fitted in the locomotive corresponding to this new Item appears in the drop-down list, then click on that maker's name. Otherwise (or if you do not know the make of decoder) click the **Basic / Other (NMRA CV Definition)** option (or the **Basic / Other (NMRA)** option button itself) –

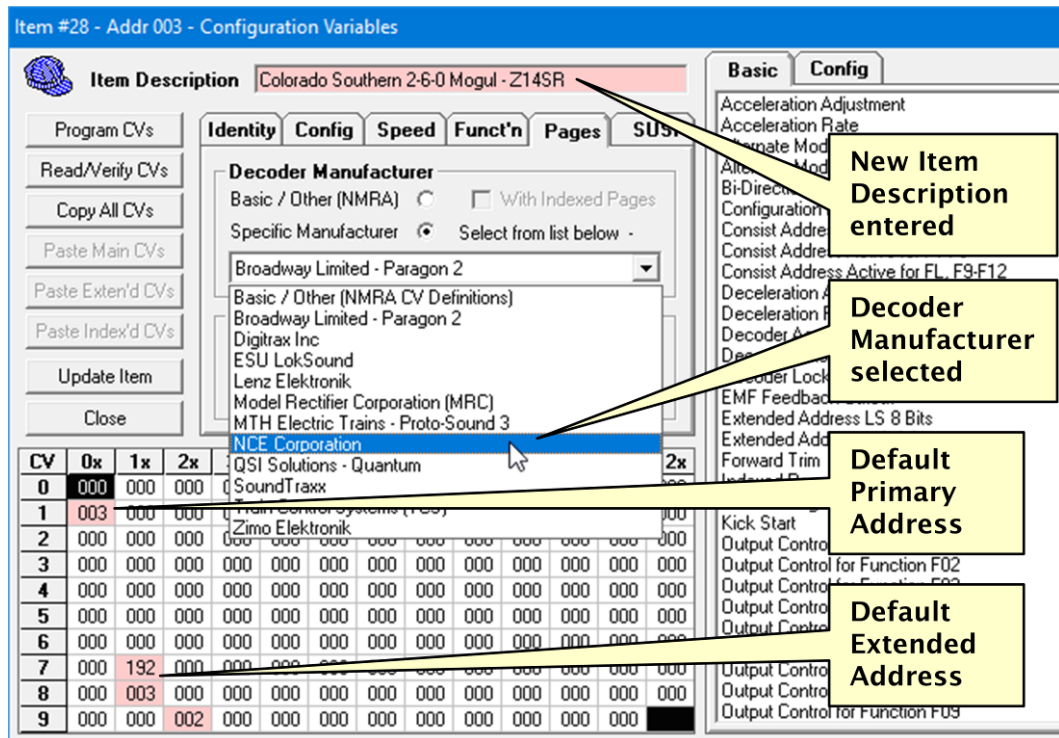

At this point, before adding any more details to your new Loco Item, the sensible step is to click the **Update Item** button to save the Item with its initial identity back to the Item List. To be doubly safe, you could also save a copy of the amended Item List back to the PC's hard disk (or other permanent storage).

Before re-opening the Item's Edit CVs window to continue (by a double-click on the saved updated Item) ensure that your NCE Command Station (Power Cab or Power Pro) is connected to the PC, powered on, and communicating correctly, ie. with the status indicators at the righthand end of the status bar showing **green**.

The next stage is to copy the current contents of the decoder fitted in the locomotive, which the Item will represent, into A-Track. This step ensures that you capture all of the CV settings preset in the decoder by the manufacturer, as a starting point before you start to enter any of your own preferred customisations.

To do this, open the Edit CVs window by double-clicking on the Item in the Item List, then place the locomotive on your programming track (or, if you are using a Power Cab and do not have a separate, switched programming track as shown in the connection diagram in **Section 1.1**, ensure that it is the **ONLY** locomotive on the main track).

Note that, if your locomotive has a sound decoder, and you are using an NCE Power Pro system, then you will generally need to connect a **programming booster unit** (such as the SoundTraxx PTB-100 or DCC Specialities PowerPax) between the Power Pro and the programming track – a booster is not usually required with an NCE Power Cab system.

Click the **Read/Verify CVs** button in the Edit CVs window to display the **Read/Verify Configuration Variables** panel where, for a first attempt at reading your locomotive decoder's CV values, you should set the **CV Range** and **Scope** options to

Current View and **All CVs**, and the **Mode** to **Paged** (See **Section 6.6** for further details of Read/Verify operations). While Direct Mode will read CV values more quickly, it is not always supported. Paged Mode is generally guaranteed to work but, the higher the CV's programmed value, the longer it takes to determine the actual value of the CV from the decoder –

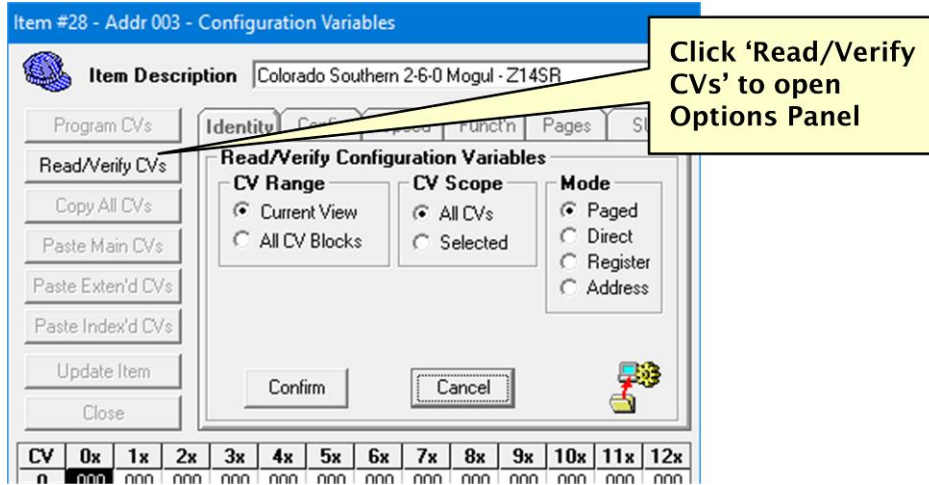

When you have set the options, click **Confirm** to start the Read/Verify operation.

During the Read/Verify operation, the CV currently being accessed will be highlighted in **red** in the grid in the lower half of the Edit CVs window. Once the CV value held in the decoder has been determined, it will be displayed in the grid and highlighted in **light green** if the value read is the *same* as that held in the Item, or highlighted in **pink** if it *differs* from the Item's stored value.

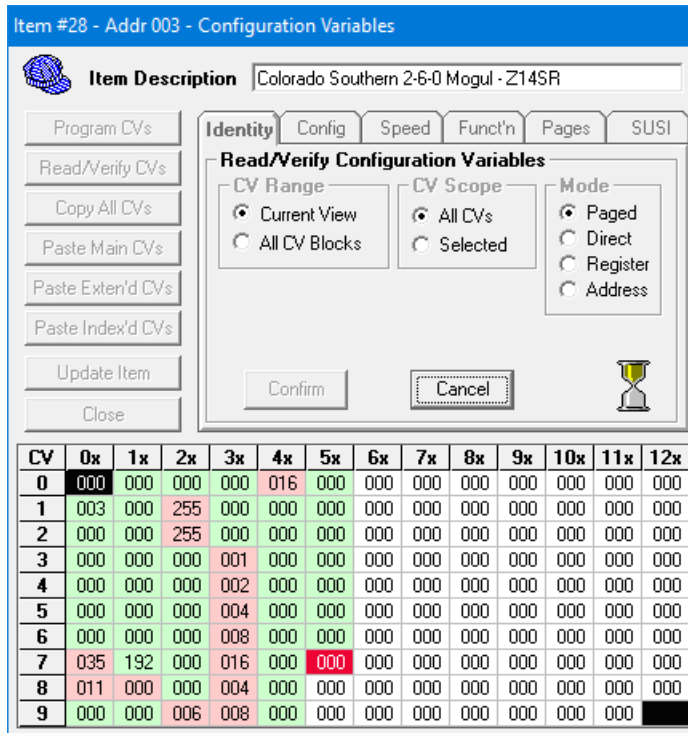

Wait patiently while the first 128 CV values are read from the decoder and displayed in the grid. If required, the whole operation can be stopped at any time by clicking the **Cancel** button, although you will have to wait for the current CV Paged Read operation to complete (up to 20 seconds).

When the Read/Verify operation is complete click the **Finish** button in the Edit CVs window. If an error occurred because of a connection problem, correct it and restart the Read/Verify operation (See **Section 6.6** for detailed instructions).

CV	0x	1x	2x	3x	4x	5x	6x	7x	8x	9x	10x	11x	12x
0	000	000	000	000	016	000	000	000	000	000	000	000	001
1	003	000	255	000	000	000	000	000	000	000	000	000	002
2	000	000	255	000	000	000	000	000	000	000	000	000	000
3	000	000	000	001	000	000	000	000	000	000	000	000	000
4	000	000	000	002	000	000	000	000	000	000	000	000	000
5	000	000	000	004	000	000	000	000	000	000	000	000	000
6	000	000	000	008	000	000	000	000	000	000	000	000	000
7	035	192	000	016	000	000	000	000	000	000	000	000	000
8	011	000	000	004	000	000	000	000	000	000	000	020	000
9	000	000	006	008	000	000	000	000	000	000	000	000	000

If all went well, you may now wish to read all of the decoder's CVs by changing the **CV Range** option to **All CV Blocks**, and perhaps the **Mode** to **Direct**.

Click the **Update Item** button at any point when it is enabled to save the Item's CV data back into the Item List and close the Edit CVs window. Repeat the operations as often as required to obtain the full set of CV values currently programmed into this locomotive's decoder, then save the updated Item List as your reference before making any of your own changes to the locomotive decoder's CV settings.

Back in the Edit CVs window, the first adjustment you are likely to make is to give the Item a unique address (or pair of addresses). Click in the **Primary Address** textbox and enter the desired Primary Address for the new Item (any value from 001 up to 127) to replace the currently-shown default value of 003, and press **Enter/Return**, or the **Tab** (↹) key (or click in any other textbox). A value of 000 can also be entered, but the Locomotive will then be configured for DC, rather than DCC, operation – and cannot be operated via an NCE Handheld Controller. The value of CV01 in the CV Value Grid is updated again, to show the new Address, and regains its pink highlight.

If you intend to operate the new Locomotive using its 4-digit **Extended Address**, then you should enter a suitable value for the Item by typing the required value into the Extended Address textbox (any value from 0000 up to 9999 is acceptable). To comply with NMRA DCC standards, the Extended Address value is converted to a hexadecimal number, the lower byte of which is stored in CV18, and the upper byte, with the value 192 (hexadecimal C0) added to it, stored in CV17. A-Track takes care of all of the calculations for you behind the scenes, and displays the result as two decimal numbers (with a pink highlight) as shown below –

Item #28 - Addr 003 - Configuration Variables

Item Description: Colorado Southern 2-6-0 Mogul - Z14SR

Program CVs
Read/Verify CVs
Copy All CVs
Paste Main CVs
Paste Exten'd CVs
Paste Index'd CVs
Update Item
Close

Identity Config Speed Funct'n Pages SUSI

Item Type
 Accessory
 Consist
 Locomotive
 Multiple
 None

Primary Address 047
 Extended Address 0547
 Consist Address 000
 User Identifier #1 000
 User Identifier #2 000
 Manufac Version N 035
 Manufactur 011

Not Allocated Edited Not Prog'd

CV	0x	1x	2x	3x	4x	5x	6x	7x	8x	9x	10x	11x	12x
0	000	000	000	000	016	000	000	000	000	000	000	000	001
1	047	000	255	000	000	000	000	000	000	000	000	000	002
2	000	000	255	000	000	000	000	000	000	000	000	000	000
3	000	000	000	001	000	000	000	000	000	000	000	000	000
4	000	000	000	002	000	000	000	000	000	000	000	000	000
5	000	000	000	004	000	000	000	000	000	000	000	000	000
6	000	000	000	008	000	000	000	000	000	000	000	000	000
7	035	194	000	016	000	000	000	000	000	000	000	000	000
8	011	035	000	004	000	000	000	000	000	000	000	020	000
9	000	000	006	008	000	000	000	000	000	000	000	000	000

Set Primary Address

Set Extended Address

Note that the two **Item Flags**, 'Edited' and 'Not Programmed' are both now shown as set, by the **red/white cross** (✘) icons. The **Edited** Flag (shown as 'E' in the Item List Flags field in Details view) is set whenever *any* change is made to an Item. The **Not Programmed** Flag (shown as 'P' in the Item List Flags field) is set whenever a CV value is altered, and the new value has not yet been transferred to the Item's real DCC decoder, or where the parameters of a Consist have been changed, but the Consist has not yet been *activated*, ie. transferred to the NCE Command Station and / or programmed directly into the DCC decoders of the constituent Locomotives (see **Sections 6.8** and **6.12**).

Both flags remain set when an edited Item is updated, and show in the Item List Flags field. The Not Programmed Flag (P) will be cleared when an Item's CV values are programmed into a decoder, as described later in **Section 6.7**, or when a Consist is activated. The Edited Flag (E) is cleared when the Item List is saved to permanent storage and A-Track is closed.

Hence, when an Item List is loaded, no Item will normally have its Edited Flag (E) set (unless from an old Item List saved before this version of A-Track has been installed) but may show the Not Programmed Flag (P) as set, if the Item List was saved without that Item's CV values being programmed into a decoder or, in the case of a Consist, without the Item having been activated.

As an option on the Identity Parameter Tab page, you can enter two numbers, each in the range 0 to 255, in the **User Identifier** textboxes. These numbers are purely for your own use to add some extra personal information to the Item, and can be programmed into the corresponding decoder (as CV105 and CV106) if you so desire. The User Identifiers are not used for any control purposes.

The second adjustment to the set-up of a new Item is to define the **Configuration** selections for CV29 by clicking on the **Config** Parameter Tab, and then clicking in the appropriate checkboxes to tick the required operational parameters –

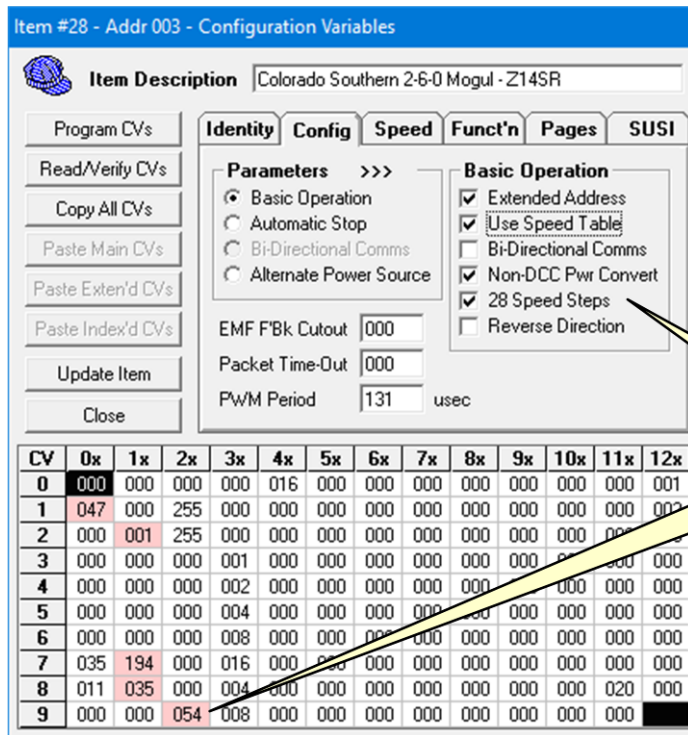

Basic Settings for CV29 (Item Configuration)

In the example above, the **Basic Operation** Configuration has been changed to use the Locomotive’s Extended Address with the existing control precision of 28 Speed Steps (the latter is selected automatically), to enable conversion to Non-DCC Power (automatic operation on DC selected by default), and to enable use of the 28-Step Speed Table, which will be described later in **Section 6.1** –

A-Track automatically translates these selected settings to a value of 54 which is entered in CV29 (Configuration Data), together with a value of 1 in CV12 (Power Source Conversion), as shown above.

Click **Update Item** to copy the new Item’s edited parameters to the Item List –

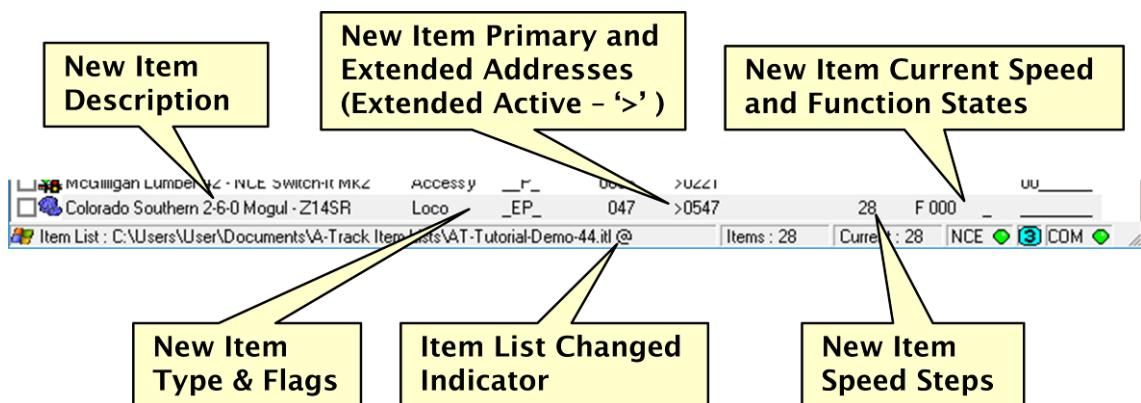

The format of the Details View shown above is fairly self-explanatory. Note that either the Primary or Extended Address is displayed with a '>' symbol in front of whichever Address has been selected as active, ie. the one which will be used to control the Item.

When this Locomotive Item is under control from the PC screen, as will be shown in **Section 6.9**, its current speed, direction, and function settings will be displayed in the righthand columns of the Details View. These details will also be shown when an Item is allocated to an NCE Cab through an NCE Command Station, when the current Cab allocation and status will be automatically updated (See **Section 6.8**).

As mentioned before, while A-Track will run quite happily as a background monitor of system operation when connected to your NCE Power Pro System, there is no requirement to run it continuously, leaving you free to start A-Track only at those times you wish to make use of its facilities.

Note also the '@' symbol now shown after the Item List filename on the status bar, to indicate that the Item List has been changed. This is a prompt to remind you that, after checking that you now have a new Locomotive Item in the Item List, you should save the changed Item List to the PC's hard disk to preserve your work.

To complete the set-up of your new Locomotive Item, you can again double-click on its entry in the Item List to re-open the Edit CVs window. Here you will be able to check the settings of all relevant CV values against the manufacturer's recommendations in the first instance, before progressively 'tuning' the parameters to give the desired performance.

As always, after making changes to the parameters of any Item, you should save the changed Item List to the PC's hard disk to preserve your work, as described previously in **Section 4.2**. Ensure, of course, that you do not overwrite and destroy the copy of the original values that you read from the locomotive decoder, and saved, when creating the Item – that is your 'safety net' if your 'tuning' and 'adjustments' go badly awry, allowing you to start over.

5.4 Editing CV Values Directly

All of the CVs specified as having unique functions in the NMRA DCC Standards and Recommended Practices can be accessed, and their values edited, using the fields incorporated in the set of Parameter Tabs. However, many of the remaining CVs, which have not been allocated specific functions by the NMRA, are used by each individual decoder manufacturer to define their own proprietary parameters and functions.

You can edit **any** of the CVs in the CV Value Grid, including these NMRA- and manufacturer-specific CVs, by **right-clicking** on the relevant cell in the CV Value Grid to bring up the **Configuration Variable Value** page in the Parameter Tabs area of the window as shown in the example below.

This page shows the number of the selected CV with its Description (as also shown on the pop-up label next to the CV location), and its current value listed in decimal, hexadecimal and binary (bits). To change the value of the CV simply click in either of the **Dec** or **Hex** textboxes and type in a new value. The value shown in the other (unclicked) textbox is updated automatically to match the entered number –

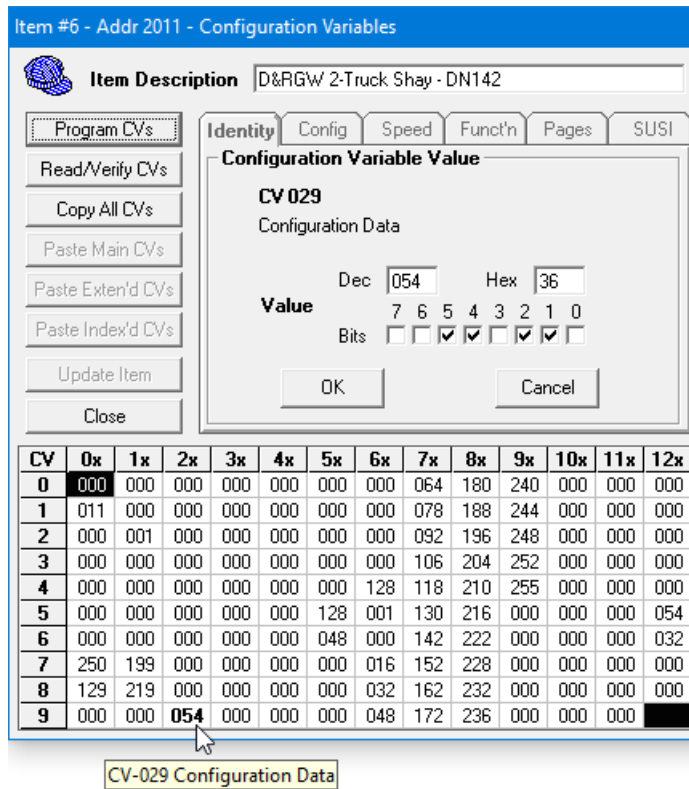

Decimal numbers are entered using the normal digits 0 to 9, while hexadecimal numbers use the letters A to F in addition to digits 0 to 9 – you can type the letters in either lower- or upper-case (small letters or capitals).

Alternatively, you can click on one or more of the **Bits** checkboxes to set or clear each individual bit of the byte representing the value of the CV. A tick in a checkbox represents a set bit (value 1), and an unticked checkbox represents a cleared bit (value 0). Again, the values in the Dec and Hex textboxes will be automatically updated to reflect the new value of the CV as each bit is changed.

Once the required CV value has been set, click **OK** to transfer the new value to the selected location in the CV Value Grid – or click **Cancel** to discard the entered value and leave the existing CV value unchanged.

Important Note : A-Track **does not perform any checks** that the value entered into the selected CV is valid, or an allowed value, for the parameter to which that CV is allocated. You must ensure that the value entered is within the limits defined by either the NMRA DCC Standards and Recommended Practices or the decoder manufacturer for the selected Configuration Variable.

You can use this facility as a simple converter to view any decimal, hexadecimal, or binary number in both of its other forms, although the range of numbers it can handle is restricted to 0 to 255 decimal (00 to FF hexadecimal, or 00000000 to 11111111 binary).

6 LOCOMOTIVE ITEM OPERATIONS

6.1 Speed and Speed Tables

For Locomotive Items, click on the **Speed** Parameter Tab to access the set of Item parameters associated with the locomotive's Speed characteristics. This Tab is not enabled for Consists or Accessories.

Item #6 - Addr 2011 - Configuration Variables

Item Description: D&RGW 2-Truck Shay - DN142

Program CVs | Identity | **Config** | Speed | Funct'n | Pages | SUSI

Read/Verify CVs

Copy All CVs

Paste Main CVs

Paste Exten'd CVs

Paste Index'd CVs

Update Item

Close

Step Precision

14 Steps

28 Steps

128 Steps

Define Tables

Simple 3-Step

Full 28-Step

Adjustment Parameters

Acceleration Rate: 000

Deceleration Rate: 000

Acceleration Adjust: 000

Deceleration Adjust: 000

Select Table / Mid Step: 000

Kick Start: 001

Forward Trim: 000

Reverse Trim: 000

CV	0x	1x	2x	3x	4x	5x	6x	7x	8x	9x	10x	11x	12x
0	000	000	000	000	000	000	000	064	180	240	000	000	000
1	011	000	000	000	000	000	000	078	188	244	000	000	000
2	000	001	000	000	000	000	000	092	196	248	000	000	000
3	000	000	000	000	000	000	000	106	204	252	000	000	000
4	000	000	000	000	000	000	128	118	210	255	000	000	000
5	000	000	000	000	000	128	001	130	216	000	000	000	054
6	000	000	000	000	000	048	000	142	222	000	000	000	032
7	250	199	000	000	000	000	016	152	228	000	000	000	000
8	129	219	000	000	000	000	032	162	232	000	000	000	000
9	000	000	054	000	000	000	048	172	236	000	000	000	000

Set the **Step Precision** you wish to use to control the locomotive – 14, 28, or 128 speed steps – but check the manufacturer's documentation to ensure that your selection is supported by the fitted decoder. The 14-Step option is really provided only for compatibility with very old decoders, and all modern decoders will normally operate under 28- or 128-Step control.

Note that the choice of 14 or 28 speed steps is reflected in the Configuration Basic Operation setting held in CV29 (Bit1). Choosing 128 speed steps does not affect any CV values directly – it only determines the type of speed command which will be generated by A-Track when using the Item Operate option, and sent to the locomotive. Selection between 28- or 128-Step commands when using an NCE Handheld Cab for Item control is made by pressing the 28/128 button on the Cab.

The **Adjustment Parameters** deal with the locomotive's momentum, ie. how it behaves when starting and stopping. If you are unsure of the most appropriate values to use, then you should refer to the manufacturer's recommendations. Simply click in the textbox relating to a selected Adjustment Parameter, type in the recommended value, and press the **Enter/Return** or **Tab** () key. The value will be transferred to the corresponding CV, where it will be displayed, and highlighted (in pink), in the CV Value Grid.

A-Track allows you to set up the two **Speed Tables** defined in the NMRA DCC standards, a simple 3-Step Table and a more comprehensive 28-Step Table. These tables are used to set the response of the locomotive to the speed commands from the Controller (Cab), in order to give an appropriate locomotive top speed, together with accurate control at low and/or high speed.

The Full 28-Step Speed Table is only effective when the 'Use Speed Table' option is selected (ticked) in the Basic Operation section on the Config Tab page. The 3-Step Speed Table is used in all other circumstances.

Clicking on the **Simple 3-Step** button shows you, graphically, the current table values, referred to as VStart, VMid, and VHigh, together with some control buttons on the left, as shown below. The vertical axis represents the relative speed corresponding to each step – 000 is stationary and 255 represents maximum (100%) speed (full track voltage applied to the locomotive motor) –

Although you can use the **Linear**, **Log**, and **Exp** buttons on the left to set values for the 3-Step Table, they are more commonly used to assist in setting up the 28-Step Table, and their actions will be described in detail later in this section.

Clicking the **Zero** button, as is fairly obvious, will set all of the VStart, VMid, and VHigh values to their default state of zero (000), as shown above, where they will have no effect on the speed characteristics of the decoder (and the Locomotive).

The normal way of setting the 3-Step Table, is simply to click within one of the three white columns on the graph, near to the desired value for VStart, VMid, or VHigh. When you press down on the left mouse button, the relevant **red marker** will change colour to **green** then, when you release the mouse button, the marker will move to the position of the mouse cursor.

The markers are constrained to move only vertically, and to stay within the limits of the vertical scale, so you can click anywhere within the relevant white column. When the mouse button is released, the current value of the associated table entry will be shown in the **yellow textbox** located next to the bottom left corner of the graphical area –

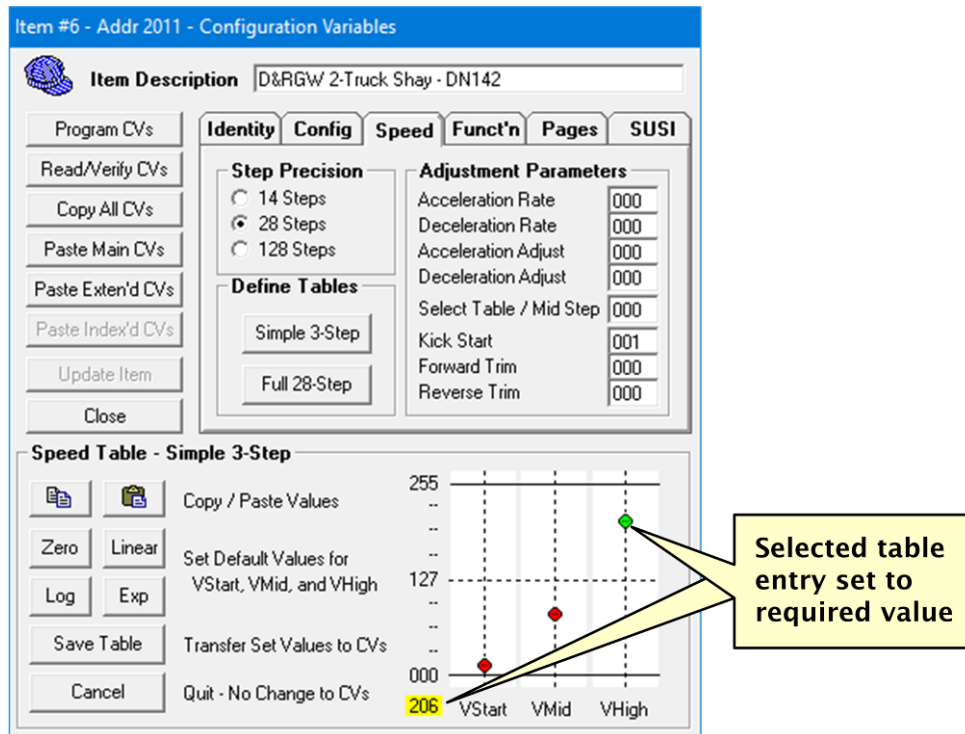

Once you have clicked in the graph area to set any Speed Table marker to an approximate value (so the marker is **green**), the Speed Table value can then be incremented or decremented by 1 unit at a time by rolling the **mousewheel** or using the **Up** and **Down Arrow** keys.

The **Page Up** and **Page Down** keys will respectively increment or decrement a selected Speed Table value by 16 units at a time, as will the **mousewheel** if either **Shift** (**⇧**) key is held down at the same time.

If you set the value of any Speed Table value incorrectly, then a press of the **Esc** (Escape) key, while the marker is **green**, will return it to the value currently held in the relevant CV (ie. return it to the value shown when you first displayed the Speed Table).

Once you are happy with all three values, click **Save Table** to transfer the values to the corresponding CVs – or click **Cancel** to discard any changes, and quit this particular operation. If you elect to Save the values, then any changes made are reflected in the appropriate CV values in the grid, and highlighted in **pink**.

As you can see in the example below, the value of VStart (13) is stored in CV02, VMid (82) in CV06, and lastly VHigh (206) in CV05 –

Item #6 - Addr 2011 - Configuration Variables

Item Description: D&RGW 2-Truck Shay - DN142

Program CVs | Identity | Config | Speed | Funct'n | Pages | SUSI

Read/Verify CVs

Copy All CVs

Paste Main CVs

Paste Exten'd CVs

Paste Index'd CVs

Update Item

Close

Step Precision

14 Steps

28 Steps

128 Steps

Adjustment Parameters

Acceleration Rate: 000

Deceleration Rate: 000

Acceleration Adjust: 000

Deceleration Adjust: 000

Select Table / Mid Step: 000

Kick Start: 001

Forward Trim: 000

Reverse Trim: 000

Define Tables

Simple 3-Step

Full 28-Step

CV	0x	1x	2x	3x	4x	5x	6x	7x	8x	9x	10x	11x	12x
0	000	000	000	000	000	000	000	064	180	240	000	000	000
1	011	000	000	000	000	000	000	092	180	240	000	000	000
2	013	001	000	000	000	000	000	092	180	240	000	000	000
3	000	000	000	000	000	000	000	092	180	204	252	000	000
4	000	000	000	000	000	000	128	118	210	255	000	000	000
5	206	000	000	000	000	000	128	001	130	216	000	000	054
6	082	000	000	000	000	048	000	142	222	000	000	000	032
7	250	199	000	000	000	016	152	228	000	000	000	000	000
8	129	219	000	000	000	000	032	162	232	000	000	000	000
9	000	000	054	000	000	000	048	172	236	000	000	000	000

Set Table points transferred to CV Values grid

Alternatively, clicking on the **Full 28-Step** button will reveal a similar graphical area showing the currently-held, user-defined Speed Table values (if any) as a **speed curve**, such as that shown below –

Item #6 - Addr 2011 - Configuration Variables

Item Description: D&RGW 2-Truck Shay - DN142

Program CVs | Identity | Config | Speed | Funct'n | Pages | SUSI

Read/Verify CVs

Copy All CVs

Paste Main CVs

Paste Exten'd CVs

Paste Index'd CVs

Update Item

Close

Step Precision

14 Steps

28 Steps

128 Steps

Adjustment Parameters

Acceleration Rate: 000

Deceleration Rate: 000

Acceleration Adjust: 000

Deceleration Adjust: 000

Select Table / Mid Step: 000

Kick Start: 001

Forward Trim: 000

Reverse Trim: 000

Define Tables

Simple 3-Step

Full 28-Step

Speed Table - Full 28-Step

3-St | Linear

Log | Exp

Save Table

Cancel

The horizontal axis represents Speed Steps (the commanded speed from the controller) and the vertical axis represents the relative speed corresponding to each Step – 000 is stationary and 255 is maximum (100%) speed.

Rather than set up a Speed Table from scratch in a new Locomotive Item, if you have one already defined for a similar locomotive, then you can first display *that* locomotive's Speed Table as above, in its own Edit CVs window, and click on the small **Copy** button (📄) to the left of the graphical area. Next, open up the Edit CVs window for the *new* Locomotive Item, click on the Speed Tab and select Full 28-Step to reveal a blank Speed Table (or at least one you are about to replace). Click on the small **Paste** button (📄) to insert the copied Speed Table into the new Item, where you can make any adjustments as described later in this Section.

If you do not have an existing 28-Step Speed Table to copy, but have already set up the simple 3-Step Speed Table, then you can use the entered 3-Step values to generate a basic 28-Step version by clicking the small **3-St** button –

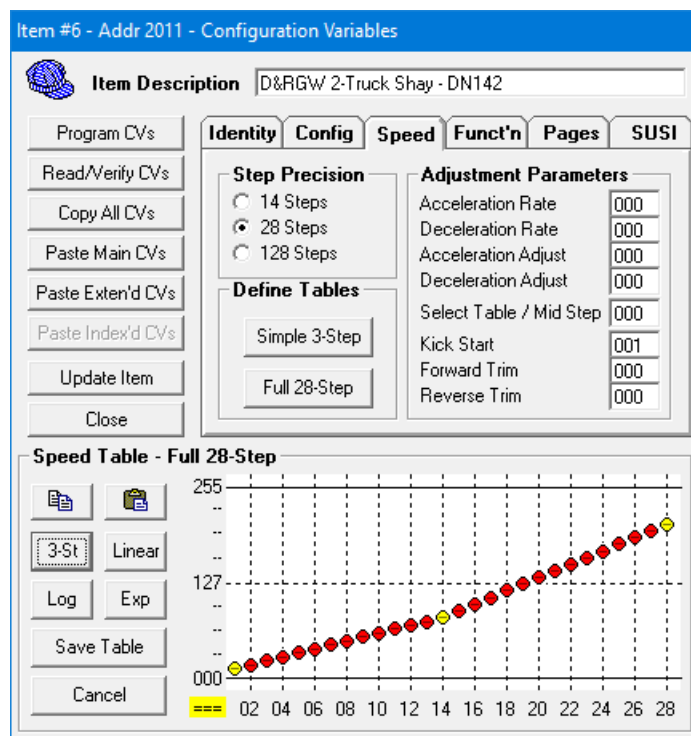

A-Track simply copies the values of VStart, VMid, and VHigh to Speed Steps 1, 14, and 28, and adjusts the values of the intervening speed steps to lie on straight lines between them.

An even simpler Speed Table is generated by clicking **Linear**, which produces a straight-line speed 'curve' between the current values of Speed Steps 1 and 28, either taken from the 3-Step Table as above, or by clicking in the relevant column for Speed Steps 1 and 28, and setting them to the values you require using the **mousewheel** with **Shift** (⇧), or the **Page Up**, **Page Down** keys, and the **Up** and **Down Arrow** keys, or the mousewheel on its own, for fine adjustment – the marker you have selected will change colour to **green**, and its actual Speed Step value will be shown in the **yellow** textbox at the bottom lefthand corner of the graph –

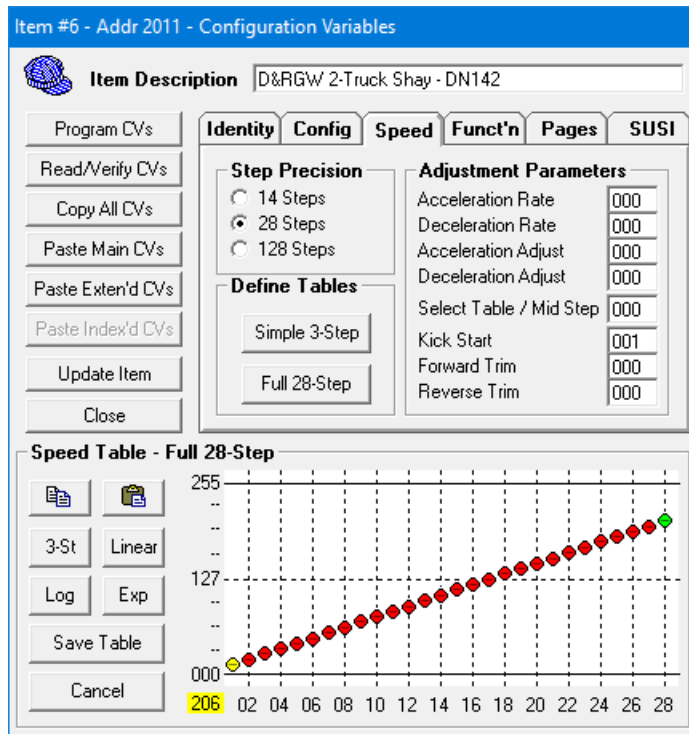

Two other options are offered to generate speed curves between the current values of Speed Steps 1 and 28. Firstly, clicking **Log** generates a logarithmic curve as shown below -

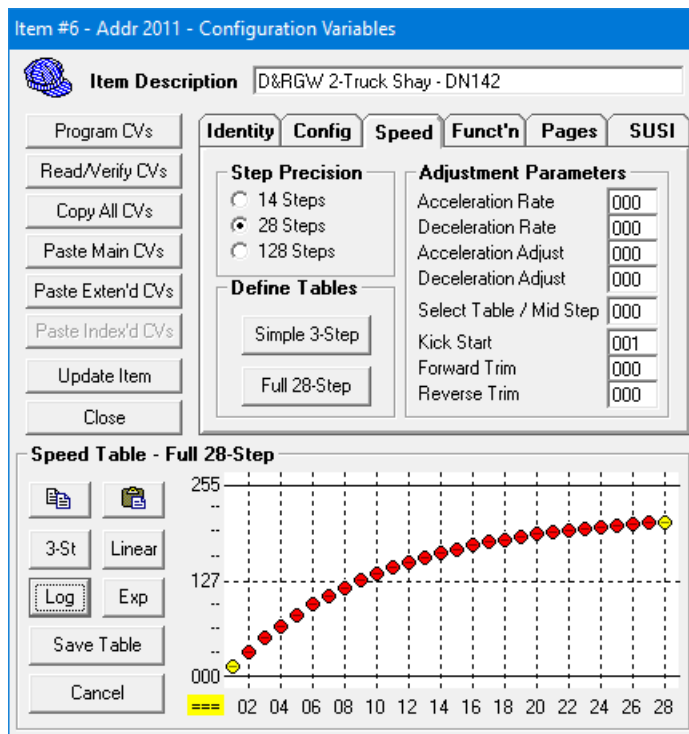

- and clicking **Exp** generates an exponential speed curve – the inverse of the logarithmic curve -

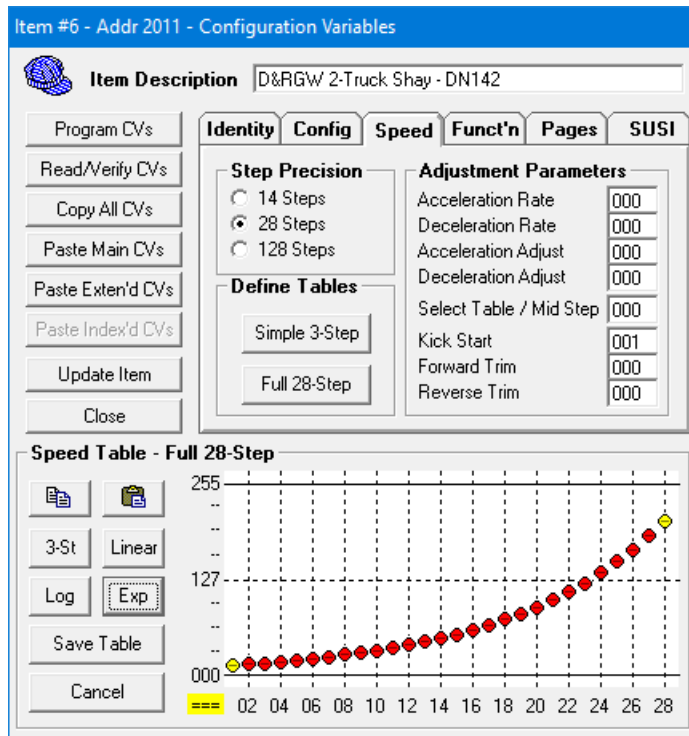

For both logarithmic and exponential speed curves, the 'steepness' of the curve is set by making small adjustments to the value of Speed Step 1. Once you have clicked on the marker for Speed Step 1 to select it (changing its colour to **green**), you can use the mousewheel, or the **Up** and **Down Arrow** keys, provide the required precise adjustment.

Any of the preset speed curves can also be scaled to a maximum desired speed. Click in the column for Speed Step 28 near to the desired maximum speed value, or click on the marker itself, then use the mousewheel with or without a Shift key, or the relevant Arrow/Page keys, to set the required Speed Step value, as shown below.

As an alternative to using the preset speed curves, you can also adjust any or all of the Speed Step values individually, to produce a speed curve of any desired shape. Press down on the left mouse button in the column above or below a selected Step, so that the relevant **red marker** changes colour to **green** then, when you release the mouse button, the marker will move to the position of the mouse cursor.

As before, fine adjustments to the Speed Step value can be made using the mousewheel (plus Shift), the **Up** and **Down Arrow** keys, or the **Page Up** and **Page Down** keys, with the current value of the adjusted Speed Step displayed in the **yellow** textbox -

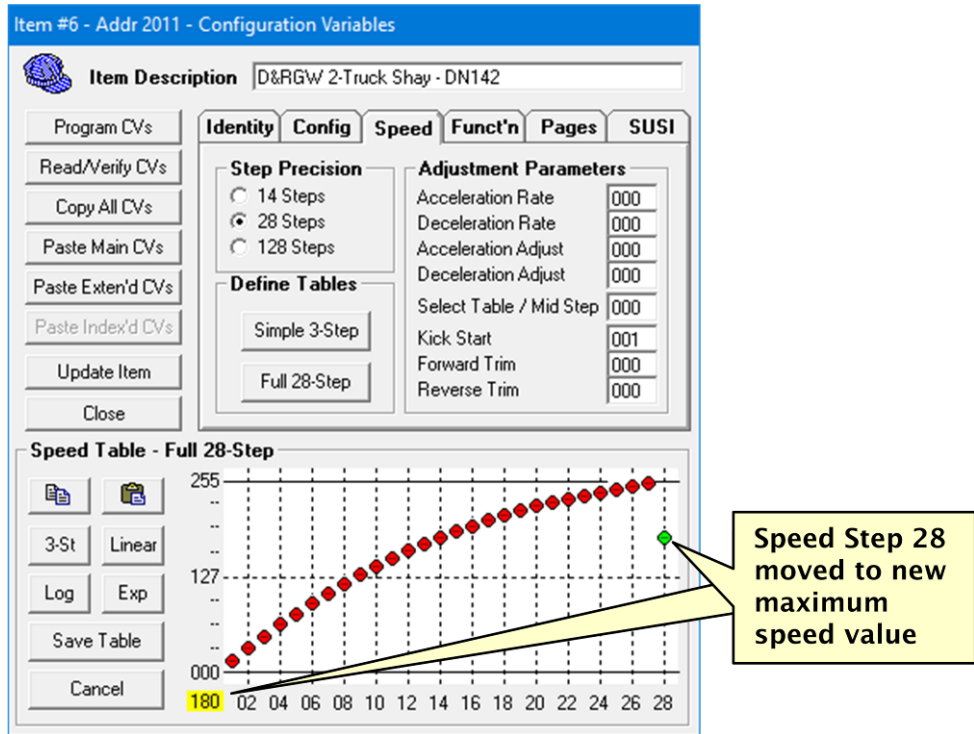

After assigning a new value to either Speed Step 1 or to Speed Step 28 (or to both), click on any one of the **Linear**, **Log**, or **Exp** buttons to set an appropriate type of speed curve. The example below shows a logarithmic curve –

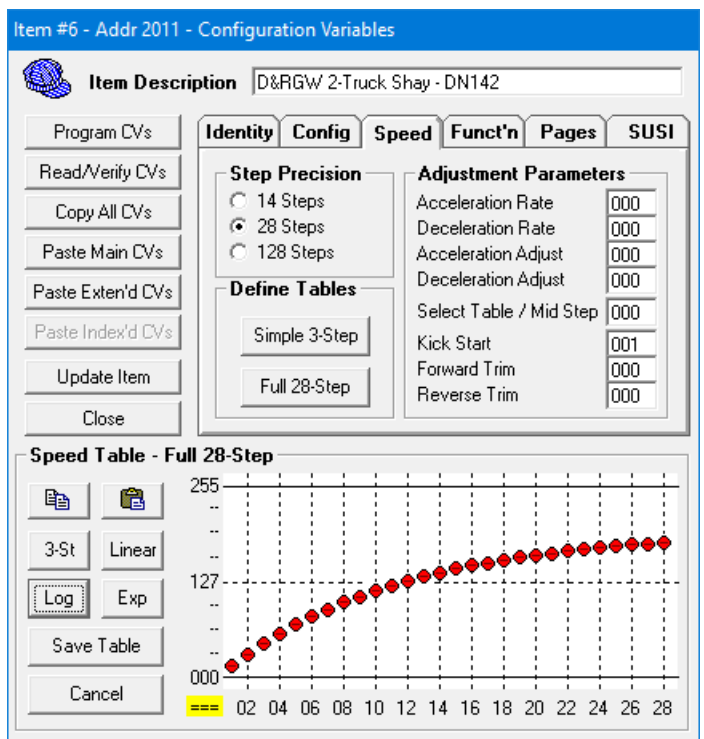

Note that, once you have selected any Speed Step marker by clicking on it (shown by its colour changing from **red** to **green**), you can move to select the adjacent marker on either side by pressing the **Left** or **Right Arrow** keys.

Also, if you decide that a newly-set Speed Step value is incorrect, pressing the **Esc** (Escape) key while the relevant marker is selected (**green**) will return that Speed Step to the value currently held in the relevant CV (ie. return it to the value shown when you first displayed the Speed Table).

If you are completely dissatisfied with your adjustments, simply click on **Cancel** at any time to discard all changes and retain the original Speed Table settings. Click on the **Full 28-Step** button once again to display the speed curve for another attempt.

Finally, when you are happy with the shape of the speed curve, click on **Save Table** to transfer the parameters of the newly-defined speed curve to the Speed Table CVs (CV67 to CV94) in the CV Value Grid, where any changed values will be highlighted in **pink** –

CV	0x	1x	2x	3x	4x	5x	6x	7x	8x	9x	10x	11x	12x
0	000	000	000	000	000	000	000	058	140	173	000	000	000
1	011	000	000	000	000	000	000	070	145	175	000	000	000
2	013	001	000	000	000	000	000	081	149	177	000	000	000
3	000	000	000	000	000	000	000	091	153	178	000	000	000
4	000	000	000	000	000	000	128	100	157	180	000	000	000
5	206	000	000	000	000	128	001	108	160	000	000	000	054
6	082	000	000	000	000	048	000	116	163	000	000	000	032
7	250	199	000	000	000	000	016	123	166	000	000	000	000
8	129	219	000	000	000	000	031	129	169	000	000	000	000
9	000	000	054	000	000	000	046	135	171	000	000	000	000

Click **Update Item** to save all changes to the Item List, then save the updated Item List as usual. Do not forget, however, that you will need to program the newly-changed CV values into the physical decoder before they will have any effect on the operation of the relevant Locomotive (see **Section 6.7**).

6.2 Functions and Function Mapping

For Locomotive Items, click on the **Funct'n** Parameter Tab to access the set of Item parameters associated with Functions. This Tab is not enabled for Consists or Accessories.

CV	0x	1x	2x	3x	4x	5x	6x	7x	8x	9x	10x	11x	12x
0	000	000	000	000	000	000	000	064	180	240	000	000	000
1	011	000	000	000	000	000	000	078	188	244	000	000	000
2	000	001	000	000	000	000	000	092	196	248	000	000	000
3	000	000	000	000	000	000	000	106	204	252	000	000	000
4	000	000	000	000	000	000	128	118	210	255	000	000	000
5	000	000	000	000	000	128	001	130	216	000	000	000	054
6	000	000	000	000	000	048	000	142	222	000	000	000	032
7	250	199	000	000	000	000	016	152	228	000	000	000	000
8	129	219	000	000	000	000	032	162	232	000	000	000	000
9	000	000	054	000	000	000	048	172	236	000	000	000	000

In the first two sections (**Enable in Alternate Power Mode** and **Active under Consist Address**), click on as many, or as few, of the checkboxes as you wish to enable a specific Function as **active** when operating the Locomotive Item in either Alternate Power Mode or as part of a Consist. An enabled Function is indicated by a tick in the relevant checkbox. Click on an enabled checkbox to remove the tick mark and disable that Function in the respective mode(s).

When not operating in either Alternate Power Mode, or as part of a Consist, any settings in these Function Parameter Tab sections are ignored.

The third, bottom section (**Function / Output Mapping**) allows you to specify which Function Outputs will react to a specified Function command, particularly where you wish to make the Function Output different from that which would normally be activated by a specific Function command. Where no selection is made, each Function simply activates its normal, corresponding Function Output.

For example, suppose you wish to swap Functions F1 and F2. First, click to select Function F1 on the top row then click the checkbox on the bottom row corresponding to Output F2 –

Fh	LF	LR	1	2	3	4	5	6	7	8	9	10	11	12
<input checked="" type="radio"/>	<input type="radio"/>	<input type="radio"/>	<input type="radio"/>	<input type="radio"/>	<input type="radio"/>	<input type="radio"/>	<input type="radio"/>	<input type="radio"/>	<input type="radio"/>	<input type="radio"/>	<input type="radio"/>	<input type="radio"/>	<input type="radio"/>	<input type="radio"/>
OP	<input type="checkbox"/>	<input type="checkbox"/>	<input checked="" type="checkbox"/>	<input type="checkbox"/>	<input type="checkbox"/>	<input type="checkbox"/>	<input type="checkbox"/>	<input type="checkbox"/>	<input type="checkbox"/>	<input type="checkbox"/>	<input type="checkbox"/>	<input type="checkbox"/>	<input type="checkbox"/>	<input type="checkbox"/>

Next, click to select Function F2 on the top row followed by the checkbox for Output F1 on the bottom row –

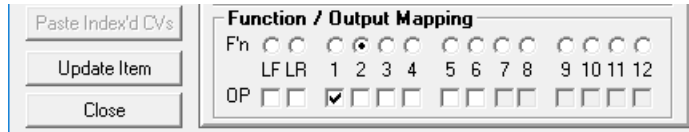

Finally, to enhance the example, suppose we wish to activate both Outputs F4 and F6 when Function F4 is invoked. Click to select Function F4 on the top row, and then select both checkboxes on the bottom row for Outputs F4 and F6 –

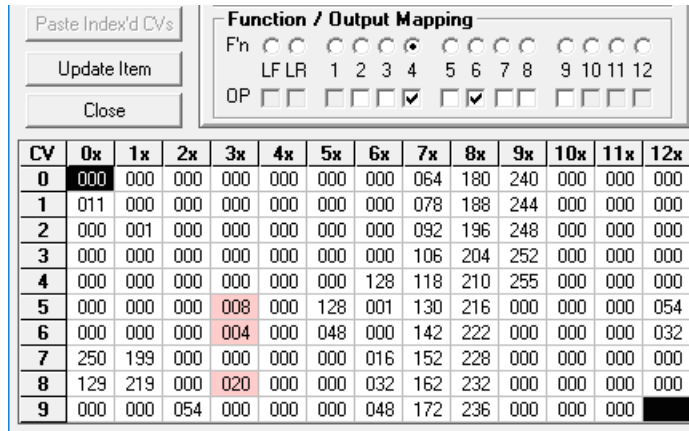

The CVs changed by the set of three Function mappings can be seen in the CV Value Grid. Note also that A-Track ensures that you can only specify valid Function mappings by 'greying-out' those OP checkboxes which are disallowed for a selected Fn button.

However, be aware that not all manufacturers implement Function / Output Mapping exactly in accordance with the NMRA Recommended Practice, and they may utilise CV 33 to CV46 differently in order to support their own mapping scheme(s).

In such a case you will find that using the standard scheme outlined above does not produce the desired result from your decoder when you press particular Function buttons on the NCE Cab. You will then need to refer to the manufacturer's user documentation for that particular decoder, work out the values to be loaded to each mapping CV, and then program the values directly into the CVs using the facility described previously in **Section 5.4**.

6.3 Accessing Further CV Pages - Sound and Complex Functions

For Locomotive Items, click on the **Pages** Parameter Tab to access the additional pages of CVs associated with decoders which provide Sound and Complex Function features. This Tab is not enabled for Consists or Accessories.

An additional panel opens, extending the normal Edit CVs window to the right, as shown below –

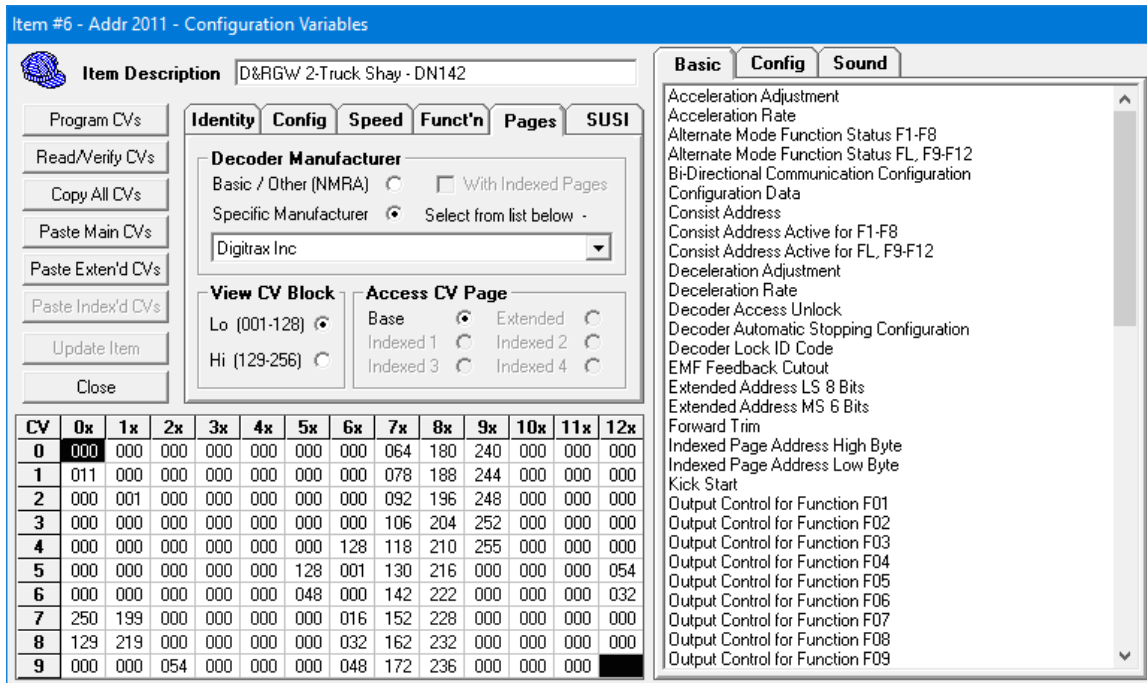

One or more **CV Description Tabs** will be displayed in the righthand panel, with each Tab containing a list of CVs, arranged alphabetically, relating to the type of DCC Decoder selected in the **Decoder Manufacturer** section of the Pages Parameter Tab. The **Basic** CV Description Tab will always be shown, regardless of the decoder type selected, with a list of all of the CVs defined in the NMRA DCC Standards and Recommended Practices.

When first accessing the **Pages** Parameter Tab, as part of the initial setup of a new Item, as described in **Section 5.3**, your first action is to select the type of decoder fitted to the Item, since this will determine the number and content of the CV Description Tabs which will be displayed.

The simplest case is where the manufacturer of the fitted decoder appears in the list which can be shown by clicking on the **Specific Manufacturer** option button, and then on the down-arrow (▼) at the righthand end of the listbox below the option button –

Item #6 - Addr 2011 - Configuration Variables

Item Description: D&RGW 2-Truck Shay - DN142

Program CVs, Read/Verify CVs, Copy All CVs, Paste Main CVs, Paste Exten'd CVs, Paste Index'd CVs, Update Item, Close

Identity Config Speed Funct'n Pages SUSI

Decoder Manufacturer
 Basic / Other (NMRA) With Indexed Pages
 Specific Manufacturer Select from list below -
 Digitrax Inc
 Basic / Other (NMRA CV Definitions)
 Broadway Limited - Paragon 2
 Digitrax Inc
 ESU LokSound
 Lenz Elektronik
 Model Rectifier Corporation (MRC)
 MTH Electric Trains - Proto-Sound 3
 NCE Corporation
 QSI Solutions - Quantum
 SoundTraxx
 Train Control Systems (TCS)
 Zimo Elektronik

CV	0x	1x	2x
0	000	000	000
1	011	000	000
2	000	001	000
3	000	000	000
4	000	000	000
5	000	000	000
6	000	000	000
7	250	199	000
8	129	219	000
9	000	000	054

Basic Config Sound

- Acceleration Adjustment
- Acceleration Rate
- Alternate Mode Function Status F1-F8
- Alternate Mode Function Status FL, F9-F12
- Bi-Directional Communication Configuration
- Configuration Data
- Consist Address
- Consist Address Active for F1-F8
- Consist Address Active for FL, F9-F12
- Deceleration Adjustment
- Deceleration Rate
- Decoder Access Unlock
- Decoder Automatic Stopping Configuration
- Decoder Lock ID Code
- EMF Feedback Cutout
- Extended Address LS 8 Bits
- Extended Address MS 6 Bits
- Forward Trim
- Indexed Page Address High Byte
- Indexed Page Address Low Byte
- Kick Start
- Output Control for Function F01
- Output Control for Function F02
- Output Control for Function F03
- Output Control for Function F04
- Output Control for Function F05
- Output Control for Function F06
- Output Control for Function F07
- Output Control for Function F08
- Output Control for Function F09

In the example above, selecting Digitrax as the decoder manufacturer results in the addition of **Config** and **Sound** CV Description Tabs which will contain lists of all those CVs used by Digitrax to control specific features provided in their range of decoders. The Config Tab covers parameters such as lighting effects and the control of momentum and acceleration, while the Sound Tab (obviously) covers the selection of specific sound effects and their relative volumes, as shown below -

Basic Config Sound

- Decoder Lock Enable/Disable
- Ditch Lights Holdover / Blink Hold Time
- Forward Light Effect - Headlight
- Function 1 Effect
- Function 2 Effect
- Function 3 Effect (FX Only)
- Function 3 Effect (FX3)
- Function 4 Effect (FX Only)
- Function 4 Effect (FX3)
- Function 5 Effect (FX3)
- Function 6 Effect (FX3)
- Function Output Select Logic Level / 12Volt
- Headlight Lamp / LED Select
- Lights FX Keep-Alive Rate
- Reset Factory Defaults
- Reverse Light Effect - Backup Light
- Scaleable Speed Stabilization - BackEMF Intensity
- Scaleable Speed Stabilization - Dynamic Compensation
- Scaleable Speed Stabilization - Static Compensation
- Torque Compensation- Switching Speed (FX3)
- Transponding & Split-Field Motor Setup

Basic Config Sound

- Air Compressor On Time
- Air Drier Rate
- Auto Coupler Sequence Threshold Value
- Bell Ring Rate / Bell Delay
- Bell Selector
- Bell Volume
- Compressor Run Rate
- Horn / Whistle Setup
- Horn / Whistle Volume
- Horn Delay Threshold
- Master Volume Control
- Miscellaneous Sounds Volume
- Mute Volume
- Notch Rate
- Notching / Slip Mode
- Prime Mover / Chuff Volume
- Sound Project Author ID
- Sound Project ID
- Sound Project Variant ID
- Sound Scheme Select
- Sound Time-Out Value
- Steam Blowdown / Safety Volume
- Steam Chuff / Cam Configuration
- Steam Gear Ratio Trim
- Time-Scattered Air Effects Volume

A left-click on the name of any CV in a Description Tab will immediately highlight the relevant CV in the CV Value grid, and display its value in the Parameter Tab area, ready for editing if required, as described previously in **Section 5.4**.

Clicking on 'Configuration Data' on the Basic tab, for example, will highlight CV29 in the CV Grid and show details of its present value (054) as shown below. To display any another CV Value simply click on its description in the list under the Basic (or any other) Tab, or click **Cancel** to return to the normal set of Parameter Tabs -

The screenshot shows a software interface for configuring a locomotive. The main window is titled 'Item #6 - Addr 2011 - Configuration Variables'. It has several tabs: 'Item Description', 'Program CVs', 'Read/Verify CVs', 'Copy All CVs', 'Paste Main CVs', 'Paste Exten'd CVs', 'Paste Index'd CVs', 'Update Item', and 'Close'. The 'Item Description' tab is active, showing 'D&RGW 2-Truck Shay - DN142'. Below this is a 'Configuration Variable Value' dialog for 'CV 029'. The dialog has 'Dec' set to '054' and 'Hex' set to '36'. There are also 'Bits' checkboxes for bits 7, 6, 5, 4, 3, 2, 1, and 0, with bits 5, 4, 3, and 2 checked. The dialog has 'OK' and 'Cancel' buttons. Below the dialog is a grid of CV values. The grid has 13 columns labeled '0x' through '12x' and 10 rows labeled '0' through '9'. The value for CV 029 is highlighted in the grid. To the right of the grid is a list of configuration parameters under the 'Basic' tab. The list includes: Acceleration Adjustment, Acceleration Rate, Alternate Mode Function Status F1-F8, Alternate Mode Function Status FL, F9-F12, Bi-Directional Communication Configuration, Configuration Data (highlighted), Consist Address, Consist Address Active for F1-F8, Consist Address Active for FL, F9-F12, Deceleration Adjustment, Deceleration Rate, Decoder Access Unlock, Decoder Automatic Stopping Configuration, Decoder Lock ID Code, EMF Feedback Cutout, Extended Address LS 8 Bits, Extended Address MS 6 Bits, Forward Trim, Indexed Page Address High Byte, Indexed Page Address Low Byte, Kick Start, Output Control for Function F01 through F09.

CV	0x	1x	2x	3x	4x	5x	6x	7x	8x	9x	10x	11x	12x
0	000	000	000	000	000	000	000	064	180	240	000	000	000
1	011	000	000	000	000	000	000	078	188	244	000	000	000
2	000	001	000	000	000	000	000	092	196	248	000	000	000
3	000	000	000	000	000	000	000	106	204	252	000	000	000
4	000	000	000	000	000	000	128	118	210	255	000	000	000
5	000	000	000	000	000	128	001	130	216	000	000	000	054
6	000	000	000	000	000	048	000	142	222	000	000	000	032
7	250	199	000	000	000	000	016	152	228	000	000	000	000
8	129	219	000	000	000	000	032	162	232	000	000	000	000
9	000	000	054	000	000	000	048	172	236	000	000	000	000

Note that, for all Decoder Manufacturers, the lists shown in the CV Description Tabs cover all parameters defined by that manufacturer over their full range of DCC decoders. Not all parameters will apply to the specific model of decoder fitted to the locomotive associated with this Item, and you should refer to the relevant manufacturer's documentation to determine which CV values should be set, and the range of values which are valid for each of these CVs.

A-Track provides specific support for decoders made by Broadway Limited (Paragon 2), Digitrax Inc, ESU (LokSound), Lenz Elektronik, Model Rectifier Corporation (MRC), MTH Electric Trains (Proto-Sound 3), NCE Corporation, QSI Solutions (Quantum), Soundtraxx, Train Control Systems (TCS), and Zimo Elektronik. Selecting a Decoder Manufacturer (which you would normally do as part of the initialisation of a new Item) sets the extent of the range of CVs which the Item can use to define all of its operational parameters.

All decoders which provide sound effects, with the exception of those made by MRC, use CVs beyond the NMRA basic range of CV01 to CV128. As defined in the NMRA Standards, the wider range of CVs is divided into **pages**, each containing 256 CV values, and A-Track further divides each page of CVs into two **blocks** of 128 CVs each.

Selection of the block to be shown in the CV Value grid is made by clicking the appropriate option button in the **View CV Block** section of the Pages Tab, with the **Lo**

button showing the lower half of the page, and the **Hi** button the upper half. Confirmation of which Block is currently on display is indicated by a number in the top left corner of the grid, **000** for the low block of the first CV page (see all preceding pictures), and **128** for the high block, as shown below –

CV	0x	1x	2x	3x	4x	5x	6x	7x	8x	9x	10x	11x	12x	
0	128	000	000	000	000	000	000	000	000	000	000	000	000	
1	000	000	000	000	000	000	000	000	000	000	000	000	000	
2	000	000	000	000	000	000	000	000	000	000	000	000	000	
3	000	000	000	000	000	000	000	000	000	000	000	000	000	
4	000	000	000	CV-180 Reserved for Manufacturer use								000	000	000
5	000	000	000	000	000	000	000	000	000	000	000	000	000	
6	000	000	000	000	000	000	000	000	000	000	000	000	000	
7	000	000	000	000	000	000	000	000	000	000	000	000	000	
8	000	000	000	000	000	000	000	000	000	000	000	000	000	
9	000	000	000	000	000	000	000	000	000	000	000	000	000	

When displaying any of the higher blocks, you can identify the number of any CV by hovering the mouse cursor over the CV in question, where a descriptive label will be displayed – as shown above for CV180.

Where the selected Decoder Manufacturer, such as Digitrax or SoundTraxx, does not use any CV greater than CV256, only the **Base** Page will be enabled in the **Access CV Page** section, as shown above. However, for decoders which use larger numbers of CVs, the next **Extended** Page (CV257 to CV512) may also be enabled. A-Track will again display the contents of the Extended Page in two Blocks, the low block (CV257-CV384) indicated by having **256** in the top left corner, and the high block (CV385-CV512) with **384**.

Two CV Pages, however, are not sufficient to accommodate the most recent generation of sound decoders from ESU (LokSound), for example, which now employ close on 900 distinct CVs across their full range of products. In this case, the CVs are accessed using an **Indexed Addressing** scheme defined by the NMRA. Rather than continue the upward numbering of CVs, each additional page of 256 CVs retains the addresses of the Extended page (CV257-CV512) but is identified uniquely by an additional Index value of 1, 2, 3, etc. An Index value of 0 identifies the "real" Extended Page.

The Page Index is set by loading appropriate values to CV31 and CV32, but this is taken care of automatically by A-Track, so that you do not need to be concerned about such details when setting up and programming your locomotive sound decoders.

Selection of ESU LokSound as the Decoder Manufacturer will enable access to four **Indexed Pages** in addition to the Base and Extended CV Pages. Half of each Page (one Block) can be viewed at any one time in the CV Value grid by selection of the required Page in the Access CV Page section together with either the low or high Block in the View CV Block area. Each of the Indexed Blocks is identified with one of the captions **X1L, X1H, . . . , X3L, X3H** appearing in the top left corner of the CV Value grid, as shown in the example below –

Item #16 - Addr 015 - Configuration Variables

Item Description: D&RGW 2-8-0 Consolidation - LokSnd Select

Program CVs, Read/Verify CVs, Copy All CVs, Paste Main CVs, Paste Exten'd CVs, Paste Index'd CVs, Update Item, Close

Identity Config Speed Funct'n Pages SUSI

Decoder Manufacturer
 Basic / Other (NMRA) With Indexed Pages
 Specific Manufacturer Select from list below -
 ESU LokSound

View CV Block
 Lo [001-128]
 Hi [129-256]
 Show All CVs

Access CV Page
 Base Extended
 Indexed 1 Indexed 2
 Indexed 3 Indexed 4

CV	0x	1x	2x	3x	4x	5x	6x	7x	8x	9x	10x	11x	12x
0	x2H	000	000	000	000	000	000	000	000	000	064	000	000
1	000	000	000	000	000	000	000	000	000	000	000	000	000
2	000	003	000	129	000	001	064	000	000	000	000	000	000
3	004	000	000	000	000	000	000	000	000	000	000	000	000
4	000	000	000	000	064	000	000	000	016	000	000	000	000
5	000	000	000	064	000	000	000	000	000	064	000	000	000
6	000	000	000	000	000	000	000	000	000	000	032	000	000
7	000	000	000	000	000	000	000	000	000	000	000	001	001
8	000	000	000	000	000	000	004	000	000	000	000	000	000
9	000	016	000	000	000	000	000	032	000	000	000	000	000

Basic Config Sound Assign Lights Assign-2

- Acceleration Adjustment
- Acceleration Rate
- Alternate Mode Function Status F1-F8
- Alternate Mode Function Status FL, F9-F12
- Bi-Directional Communication Configuration
- Configuration Data
- Consist Address
- Consist Address Active for F1-F8
- Consist Address Active for FL, F9-F12
- Deceleration Adjustment
- Deceleration Rate
- Decoder Access Unlock
- Decoder Automatic Stopping Configuration
- Decoder Lock ID Code
- EMF Feedback Cutout
- Extended Address LS 8 Bits
- Extended Address MS 6 Bits
- Forward Trim
- Indexed Page Address High Byte
- Indexed Page Address Low Byte
- Kick Start
- Output Control for Function F01
- Output Control for Function F02
- Output Control for Function F03
- Output Control for Function F04
- Output Control for Function F05
- Output Control for Function F06
- Output Control for Function F07
- Output Control for Function F08
- Output Control for Function F09

When a Block of CVs from an Extended or Indexed Page is being displayed, only those CVs which have a purpose defined by the selected manufacturer will have their values shown. All other cells in the CV Value grid will be 'greyed-out', as can be seen in the example below, and made inactive, so that they do not respond to any mouse clicks. Marking inactive CVs in this way speeds up Read/Verify or Program operations (See **Sections 6.6** and **6.7**) since time is not wasted in attempting to access decoder CVs without any declared function –

Paste Index'd CVs, Update Item, Close

View CV Block
 Lo [001-128]
 Hi [129-256]
 Show All CVs

Access CV Page
 Base Extended
 Indexed 1 Indexed 2
 Indexed 3 Indexed 4

CV	0x	1x	2x	3x	4x	5x	6x	7x	8x	9x	10x	11x	12x
0	x1L												
1		099			128					128			
2													
3	099				128				060				128
4													
5				128				128				128	
6													
7			099				123				128		
8													
9		128				128				128			

- Deceleration Rate
- Decoder Access Unlock
- Decoder Automatic Stopping Configuration
- Decoder Lock ID Code
- EMF Feedback Cutout
- Extended Address LS 8 Bits
- Extended Address MS 6 Bits
- Forward Trim
- Indexed Page Address High Byte
- Indexed Page Address Low Byte
- Kick Start
- Output Control for Function F01
- Output Control for Function F02
- Output Control for Function F03
- Output Control for Function F04
- Output Control for Function F05
- Output Control for Function F06
- Output Control for Function F07
- Output Control for Function F08
- Output Control for Function F09

If you wish to access these hidden CVs (when, perhaps, a new version of the decoder is released with additional functionality, or you simply wish to use **Read /Verify** to capture a full record of the decoder's contents) then you can 'unmask' all CVs in this *and all other Extended or Indexed blocks* by clicking on the **Show All CVs** checkbox in the **View CV Block** section, with the result shown below (where you can see that ESU actually utilises some of these undefined CV locations to store data) –

Item #16 - Addr 015 - Configuration Variables

Item Description: D&RGW 2-8-0 Consolidation - LokSnd Select

Program CVs: Read/Verify CVs, Copy All CVs, Paste Main CVs, Paste Exten'd CVs, Paste Index'd CVs, Update Item, Close

Identity: Decoder Manufacturer (Basic / Other (NMRA) With Indexed Pages, Specific Manufacturer: Select from list below - ESU LokSound)

View CV Block: Lo (001-128) , Hi (129-256) , Show All CVs

Access CV Page: Base , Extended , Indexed 1 , Indexed 2 , Indexed 3 , Indexed 4

CV	0x	1x	2x	3x	4x	5x	6x	7x	8x	9x	10x	11x	12x
0	XTL	000	001	128	000	000	001	128	000	000	001	128	000
1	000	099	128	000	000	128	128	000	000	128	128	000	000
2	000	001	150	000	000	001	128	000	000	001	128	000	000
3	099	128	000	000	128	128	000	000	060	128	000	000	128
4	001	CV-1.278 Not Used	000	000	000	128	000	000	001	128	000	000	001
5	128	000	000	128	128	000	000	128	128	000	000	128	128
6	180	000	000	001	128	000	000	001	128	000	000	001	128
7	000	000	CV-1.331 Slot 10 Volume - Conductor Whistle / Crossing Comms	000	000	000	000	001	128	000	000	001	128
8	000	000	001	128	000	000	001	128	000	000	001	128	000
9	000	128	128	000	000	128	128	000	000	128	128	000	000

Functions list: Acceleration Adjustment, Acceleration Rate, Alternate Mode Function Status F1-F8, Alternate Mode Function Status FL, F9-F12, Bi-Directional Communication Configuration, Configuration Data, Consist Address, Consist Address Active for F1-F8, Consist Address Active for FL, F9-F12, Deceleration Adjustment, Deceleration Rate, Decoder Access Unlock, Decoder Automatic Stopping Configuration, Decoder Lock ID Code, EMF Feedback Cutout, Extended Address LS 8 Bits, Extended Address MS 6 Bits, Forward Trim, Indexed Page Address High Byte, Indexed Page Address Low Byte, Kick Start, Output Control for Function F01-F09.

As for all other CV Blocks, when you pause the mouse cursor over any CV value in the grid, the pop-up label describing the function (if any) allocated to that CV is displayed with the CV Address prefixed with the Page Index, as shown in the example above, where the cursor is over CV-1.331 (ie. CV 331 in Index Page 1) which holds the Volume level for a specific sound feature programmed into this make of decoder. Note also (in the inset group of CVs) that CV 278, which has no defined function for this decoder, is nevertheless used to hold data of some kind – you are recommended, therefore not to attempt to program such ‘unused’ CVs.

You should refer to the manufacturer’s data sheet or user manual for details of how to set and adjust each CV value in order to obtain the particular operational function, or type and volume of sound, you require from the specific decoder.

With so many CV locations available for use, searching through all of the available Blocks for the value you wish to check or edit becomes impractical, even if you become very familiar of how the manufacturer arranges the various groups of CVs.

Hence, in order to locate the particular CV you require, click on the **Description Tab** appropriate to the CV category, then click on the description of the CV (all Lists are arranged in alphabetical order). This will immediately display the relevant Block in the CV Value grid, highlight the required CV, and display its value for editing in the Parameter Tabs area, as described in **Section 5.4**.

An example is shown below, where the parameter ‘Diesel Manual Notching Offset’ has been selected from the **Config** Description Tab. A-Track has opened the high Block of the Base Page and highlighted, in bold text, the correct CV (CV131) which currently contains the value 012 (CV Grid Column 0x / Row 3) –

Item #16 - Addr 015 - Configuration Variables

Item Description: D&RGW 2-8-0 Consolidation - LokSnd Select

Program CVs, Read/Verify CVs, Copy All CVs, Paste Main CVs, Paste Exten'd CVs, Paste Index'd CVs, Update Item, Close

Identity Config Speed Funct'n Pages SUSI

Configuration Variable Value

CV 131
Diesel Manual Notching Offset /Assign Fn - Stop-Forward C (V3.5)

Dec: 012 Hex: 0C

Value: 7 6 5 4 3 2 1 0
Bits:

OK Cancel

CV	0x	1x	2x	3x	4x	5x	6x	7x	8x	9x	10x	11x	12x
0	128	000	000	000	000	000	000	000	000	000	000	000	000
1	015	000	000	000	000	000	000	000	000	000	000	000	008
2	005	000	000	000	000	000	000	000	000	000	000	000	000
3	012	000	000	000	000	000	000	000	000	000	000	000	000
4	080	000	000	000	000	000	000	000	000	000	000	000	000
CV-131 Diesel Manual Notching Offset /Assign Fn - Stop-Forward C (V3.5)													000
6	148	000	000	000	000	000	000	000	000	000	000	000	000
7	000	000	000	000	000	000	000	000	000	000	000	000	000
8	000	031	000	000	000	000	000	000	000	000	000	000	000
9	000	152	000	000	000	000	000	000	000	000	000	000	000

Basic Config Sound Assign Lights Assign-2

- ABC Mode Threshold
- AC Mode Voltage - Maximum Speed
- AC Mode Voltage - Start Speed
- Analog Mode Select
- Analogue Function Voltage Offset
- Analogue Motor Voltage Offset
- Automatic Decoupling Push Time
- Automatic Decoupling Removal Time
- Automatic Decoupling Speed
- Brake Mode
- Brake Mode Configuration
- Constant Brake Mode (Brake Rate)
- Constant Brake Stopping Distance (Backward)
- Constant Brake Stopping Distance (Forward)
- DC Mode Voltage - Maximum Speed
- DC Mode Voltage - Start Speed
- Diesel Manual Notching Offset**
- Extended Configuration #1
- Extended Configuration #2 / Auxiliary Settings
- Grade Crossing Holding Time
- Load-BackEMF Control Dynamic Operating Range
- Load-BackEMF Control Parameter "K"
- Load-BackEMF Control Reference Voltage
- Load-BackEMF Control Slow Speed Parameter "K" / Helper Mode
- Load-BackEMF Control Parameter "I"
- Minimum Steam Chuff Distance
- Power Fail Bypass
- Protocol Select
- FailCom Configuration
- Secondary Steam Chuff Trigger

Note, in the particular example selected above, while CV131 is used by LokSound for the 'Diesel Manual Notching Offset' parameter in their current Version 4 decoders, it is also used for a completely different Function Assignment purpose in their earlier Version 3.5 decoders. If you select 'Assign Function – Stop-Forward C (V3.5)' from the **Assign** Description Tab then you will find that you will again end up at CV131, as shown below –

Item #16 - Addr 015 - Configuration Variables

Item Description: D&RGW 2-8-0 Consolidation - LokSnd Select

Program CVs, Read/Verify CVs, Copy All CVs, Paste Main CVs, Paste Exten'd CVs, Paste Index'd CVs, Update Item, Close

Identity Config Speed Funct'n Pages SUSI

Configuration Variable Value

CV 131
Diesel Manual Notching Offset /Assign Fn - Stop-Forward C (V3.5)

Dec: 012 Hex: 0C

Value: 7 6 5 4 3 2 1 0
Bits:

OK Cancel

Basic Config Sound Assign Lights Assign-2

- Assign Fn - Sensor2-Forward A (V3.5)
- Assign Fn - Sensor2-Forward B (V3.5)
- Assign Fn - Sensor2-Forward C (V3.5)
- Assign Fn - Sensor2-Reverse A (V3.5)
- Assign Fn - Sensor2-Reverse B (V3.5)
- Assign Fn - Sensor2-Reverse C (V3.5)
- Assign Fn - Stop-Backup A (V3.5)
- Assign Fn - Stop-Backup B (V3.5)
- Assign Fn - Stop-Backup C (V3.5)
- Assign Fn - Stop-Forward A (V3.5)
- Assign Fn - Stop-Forward B (V3.5)
- Assign Fn - Stop-Forward C (V3.5)**
- Assign Select-Fn - F00(F) Logic #1
- Assign Select-Fn - F00(F) Logic #2
- Assign Select-Fn - F00(F) Physical
- Assign Select-Fn - F00(F) Sound #1
- Assign Select-Fn - F00(F) Sound #2

An abbreviated summary of the possible different assignments for each CV is shown on the pop-up label which appears when you hover the mouse cursor over that CV in the CV Grid.

For the LokSound range there are also appreciable differences between the Select decoders and the standard Version 4 decoders regarding the Function Assignment CVs (note the use of two **Assign** Tabs). There are separate Description Tab entries for each type of decoder, as you can see in the fragment of the Assign List shown above, so take care to select the appropriate entries for your own equipment.

The latest range of sound decoders produced by QSI (Quantum) have a similar complexity to the ESU (LokSound) products, with almost 700 CVs to define the locomotive's operating parameters. The Quantum range have their own unique (and complex) indexing scheme to access each CV but, to keep things as simple as possible, A-Track handles all of the complexity behind the scenes, and presents the various groups of Quantum CVs in a set of four 'psuedo' Indexed Pages similar to those used for all other complex decoders. Each of the Quantum Indexed Blocks are identified with one of the captions **Q1L, Q1H, . . . , Q3L, Q3H** appearing in the top left corner of the CV Value grid, as shown in the example below -

The screenshot shows the 'Item #12 - Addr 122 - Configuration Variables' window. The 'Item Description' is 'Union Pacific Challenger - QSI Titan Steam'. The 'Decoder Manufacturer' is 'QSI Solutions - Quantum'. The 'View CV Block' is 'Lo (001-128)'. The 'Access CV Page' is 'Indexed 2'. The CV grid shows values for CVs 0 through 9. A pop-up label for CV-55.73.0 Reverse Light Initial State is displayed over the value 001 in the 2x column of row 3.

CV	0x	1x	2x	3x	4x	5x	6x	7x	8x	9x	10x	11x	12x
0	Q2L	001	001	001	032	000	000	000	000	000	000	000	000
1	000	086	160	003	004	000	000	000	000	000	000	000	000
2	000	032	032	001	255	000	000	000	000	000	000	000	000
3													
4													
5	000	000	000	000	000	000	000	000	000	000	000	000	000
6	000	000	000	100	000	000	000	000	000	000	000	000	000
7		127	127		127		000		000		000	000	000
8	000	127	127		127				000		000	000	000
9	000										000	000	

Again, when a Block of CVs is being displayed, unused grid cells are 'greyed-out', and do not respond to any mouse clicks, but note that in this case there are no 'hidden' CVs in these cells. Also, as normal, and as is shown above, when you pause the mouse cursor over any CV value in the grid, the pop-up label describing the function allocated to that CV is displayed with the CV Address.

For Quantum decoders, this CV Address is made up of three parts comprising the number of the CV used in the Base Page to retrieve the value of the CV from the decoder, followed by the Primary Index (a value loaded to CV49 prior to accessing the CV value), and finally the Secondary Index (a value preset in CV50). In the example above, the cursor is over CV-55.73.0 which holds the Reverse Light Initial State.

The full range of defined Quantum CVs are displayed in numerical order through all eight Indexed Blocks but, like other complex decoders, the easiest way of finding the CV value you wish to check or edit is to click on the **Description Tab** appropriate to the CV category, then click on the description of the CV (all Lists are arranged in alphabetical order). This will immediately display the relevant Block in the CV Value grid, highlight the required CV in bold text, and display its value for editing in the Parameter Tabs area, as described in **Section 5.4**.

Hence, to locate the CV highlighted in the previous example, select the **Lights** Description Tab, scroll down to find 'Reverse Light Initial State', and click on it. A-Track opens the low Block of Indexed Page 2 (**Q2L**) and highlights the correct CV (CV-55.73.0) which currently contains the value 001 (CV Grid Column 2x / Row 0) –

CV	0x	1x	2x	3x	4x	5x	6x	7x	8x	9x	10x	11x	12x
0	Q2L	001	001	001	032	000	000	000	000	000	000	000	000
1	000	086	160	003	004	000	000	000	000	000	000	000	000
2	000	032	032	001	255	000	000	000	000	000	000	000	000
3	000	255	255	001	032	000	000	000	000	000	000	000	000
4	000			001		000		000		000		000	000
5	000	000	000	000	000	000	000	000	000	000	000	000	000
6	000	000	000	100	000	000	000	000	000	000	000	000	000
7	000	127	127		127			000		000		000	000
8	000	127	127		127			000		000		000	000
9	000										000	000	

A-Track handles all of the QSI CV Indexing mechanism automatically, including inserting the required index values in CV49 and CV50, so that you can access any of the CV values in very much the same way as for any other decoder.

Note : If you have any Items with Quantum decoders which were set up under Version 4.1, or an earlier release, of A-Track, which had a simpler CV format, then they will be converted to the new Indexed Page format automatically as soon as you open the Edit CVs window for the Item. Because of this, the **Update Item** Action Button will then be enabled even if you make no explicit changes to the Item yourself. If you choose to use the **Close** button to terminate the edit, then you will be prompted to save the changed Item back to the Item List.

Warning : Once you have selected a Decoder Manufacturer which uses Indexed Pages, and load (and save) data from a decoder into the Item’s Indexed Pages, then, at a later time, if you re-open the Item and change the Decoder Manufacturer selection, you will *lose any CV data* loaded to those Pages. If you do this by accident, you can recover by clicking **Close** and choosing *not* to update the Item.

When you have a locomotive decoder from a manufacturer other than the eleven who are currently supported directly, selecting the **Basic / Other (NMRA)** option in the Decoder Manufacturer area of the Pages Parameter Tab provides the Item with access to both Base and Extended CV Pages, with the further option to use up to four Indexed CV Pages, as shown in the example below –

Item #28 - Addr 0547 - Configuration Variables

Item Description: Colorado Southern 2-6-0 Mogul

Program CVs
Read/Verify CVs
Copy All CVs
Paste Main CVs
Paste Exten'd CVs
Paste Index'd CVs
Update Item
Close

Identity Config Speed Funct'n Pages SUSI

Decoder Manufacturer
Basic / Other (NMRA) With Indexed Pages
Specific Manufacturer Select from list below -
Basic / Other (NMRA CV Definitions)

View CV Block
Lo (001-128)
Hi (129-256)

Access CV Page
Base Extended
Indexed 1 Indexed 2
Indexed 3 Indexed 4

CV	0x	1x	2x	3x	4x	5x	6x	7x	8x	9x	10x	11x	12x
0	000	000	000	000	016	000	000	000	000	000	000	000	001
1	047	000	255	000	000	000	000	000	000	000	000	000	002
2	000	001	255	000	000	000	000	000	000	000	000	000	000
3	000	000	000	001	000	000	000	000	000	000	000	000	000
4	000	000	000	002	000	000	000	000	000	000	000	000	000
5	000	000	000	004	000	000	000	000	000	000	000	000	000
6	000	000	000	008	000	000	000	000	000	000	000	000	000
7	035	194	000	016	000	000	000	000	000	000	000	000	000
8	011	035	000	004	000	000	000	000	000	000	000	020	000
9	000	000	054	008	000	000	000	000	000	000	000	000	000

Basic
Acceleration Adjustment
Acceleration Rate
Alternate Mode Function Status F1-F8
Alternate Mode Function Status FL, F9-F12
Bi-Directional Communication Configuration
Configuration Data
Consist Address
Consist Address Active for F1-F8
Consist Address Active for FL, F9-F12
Deceleration Adjustment
Deceleration Rate
Decoder Access Unlock
Decoder Automatic Stopping Configuration
Decoder Lock ID Code
EMF Feedback Cutout
Extended Address LS 8 Bits
Extended Address MS 6 Bits
Forward Trim
Indexed Page Address High Byte
Indexed Page Address Low Byte
Kick Start
Output Control for Function F01
Output Control for Function F02
Output Control for Function F03
Output Control for Function F04
Output Control for Function F05
Output Control for Function F06
Output Control for Function F07
Output Control for Function F08
Output Control for Function F09

In order to add four Indexed Pages to the Item, click to tick the **With Indexed Pages** checkbox next to the Basic / Other option, with the result shown below –

Item #28 - Addr 0547 - Configuration Variables

Item Description: Colorado Southern 2-6-0 Mogul

Program CVs
Read/Verify CVs
Copy All CVs
Paste Main CVs
Paste Exten'd CVs
Paste Index'd CVs
Update Item
Close

Identity Config Speed Funct'n Pages SUSI

Decoder Manufacturer
Basic / Other (NMRA) With Indexed Pages
Specific Manufacturer Select from list below -
Basic / Other (NMRA CV Definitions)

View CV Block
Lo (001-128)
Hi (129-256)

Access CV Page
Base Extended
Indexed 1 Indexed 2
Indexed 3 Indexed 4

CV	0x	1x	2x	3x	4x	5x	6x	7x	8x	9x	10x	11x	12x
0	000	000	000	000	016	000	000	000	000	000	000	000	001
1	047	000	255	000	000	000	000	000	000	000	000	000	002
2	000	001	255	000	000	000	000	000	000	000	000	000	000

Basic
Acceleration Adjustment
Acceleration Rate
Alternate Mode Function Status F1-F8
Alternate Mode Function Status FL, F9-F12
Bi-Directional Communication Configuration
Configuration Data
Consist Address
Consist Address Active for F1-F8
Consist Address Active for FL, F9-F12
Deceleration Adjustment
Deceleration Rate
Decoder Access Unlock
Decoder Automatic Stopping Configuration
Decoder Lock ID Code
EMF Feedback Cutout
Extended Address LS 8 Bits
Extended Address MS 6 Bits
Forward Trim
Indexed Page Address High Byte
Indexed Page Address Low Byte
Kick Start
Output Control for Function F01

Although the Basic / Other selection gives you an Item where you can handle the full range of CVs for the most complex decoders, with access to all CV Pages, it does suffer from the disadvantage that it only has a single Basic Description Tab. Hence, you will need to refer to the manufacturer's documentation in order to identify which CVs you need to access and program in order to extract the required functionality from the decoder.

Consideration will be given to supporting decoders from other manufacturers in future releases of A-Track if there is sufficient demand from users.

6.4 Serial User Standard Interface (SUSI)

SUSI is an interface for adding a slave or secondary decoder to the primary DCC decoder, proposed by the German company Dietz Modellbahntechnik. It is intended to support sound and complex function decoders, and has been provisionally incorporated in the NMRA DCC standards, where it is allocated the use of CV897 to CV1024, inclusive.

Although SUSI does not appear to have achieved any general acceptance, and is not incorporated in any product from the major DCC manufacturers, other than in some decoders from Lenz, it is supported by A-Track - to be fully compliant with the NMRA DCC standards. Even when a decoder features SUSI, programming of the attached secondary decoder is usually handled by the manufacturer through settings made to the CVs of the primary decoder, rather than directly according to the NMRA standards.

For Locomotive or Multiple Items click on the **SUSI** Parameter Tab to reveal the available options (note that the Tab is not enabled for Consists or Accessories).

The options available under the SUSI Tab allow you to set the defined CV values for all subsets of the SUSI parameters -

The screenshot shows the 'SUSI' configuration window for 'Item #18 - Addr 0606 - Configuration Variables'. The 'Item Description' is 'Clear Lake Lumber 2-Truck Climax - ZimoMX648R'. The 'SUSI' tab is selected, showing the following options:

- Range:** SUSI - I, SUSI - II, SUSI - III
- Select:** Sound, Function, Features
- Module Identity:** Manufac ID: 000, Version ID: 000

Below these options is a 'Sound - Volume Range / Number Select' table:

Vol	000	F03	000	F07	000	F11	000
F00	000	F04	000	F08	000	F12	000
F01	000	F05	000	F09	000		
F02	000	F06	000	F10	000		

At the bottom of the window is a CV table:

CV	0x	1x	2x	3x	4x	5x	6x	7x	8x	9x	10x	11x	12x
0	896	000	000	000	000	000	000	000	000	000	000	000	000
1	000	000	000	000	000	000	000	000	000	000	000	000	000
2	000	000	000	000	000	000	000	000	000	000	000	000	000
3	000	000	000	000	000	000	000	000	000	000	000	000	000
4	000	000	000	000	000	000	000	000	000	000	000	000	000
5	000	000	000	000	000	000	000	000	000	000	000	000	000
6	000	000	000	000	000	000	000	000	000	000	000	000	000
7	000	000	000	000	000	000	000	000	000	000	000	000	000
8	000	000	000	000	000	000	000	000	000	000	000	000	000
9	000	000	000	000	000	000	000	000	000	000	000	000	000

However, A-Track does not provide any further operational support for SUSI-equipped decoders, and will not do so until use of SUSI becomes more widespread.

For further details on the SUSI specification see the relevant section of the NMRA DCC standards and the referenced supporting documentation.

6.5 Transferring CV Values Between Items

When initialising the CVs for a new Item added to your roster, it can save a lot of time if you copy the current values from a similar existing Item (and generally with the same make, if not necessarily the same model, of decoder). Then, instead of having to set every single value from scratch, you should only need to alter a small set of key values, including (normally) the Primary and Extended Addresses.

Open an Edit CVs window for the Item which contains the set of CVs you wish to copy, then simply click on **Copy All CVs** to transfer all CV values to the CV Copy Buffer, a private area of memory within A-Track –

Item #16 - Addr 015 - Configuration Variables

Item Description: D&RGW 2-8-0 Consolidation - LokSnd Select

Program CVs | Identity | Config | Speed | Funct'n | Pages | SUSI

Read/Verify CVs

Copy All CVs

Paste Main CVs

Paste Exten'd CVs

Paste Index'd CVs

Update Item

Close

Item Type: Locomotive

Primary Address: 015

Extended Address: 2515

User Identifier #1: 000

User Identifier #2: 000

Manufac Version No.: 168

Manufacturer ID: 151

Not Allocated: 00

Not Prog'd

CV	0x	1x	2x	3x	4x	5x	6x	7x	8x	9x	10x
0	000	000	000	000	000	002	160	011	058	168	000
1	015	000	000	016	000	000	075	015	066	188	000
2	002	000	000	003	000	032	200	018	074	208	000
3	040	128	000	000	000	140	100	022	082	230	000
4	030	003	000	000	000	048	100	026	090	255	000
5	064	000	000	000	000	032	025	030	100	128	000
6	022	000	000	000	000	255	128	034	110	000	000
7	168	201	024	000	003	143	003	040	124	000	000
8	151	211	000	000	001	043	005	046	136	000	000
9	000	000	006	000	019	128	008	052	152	000	000

As soon as the copy is complete, the **Paste Main CVs** and **Paste Exten'd CVs** buttons will be enabled. If the Item you are copying is set up to use Indexed CV Pages, as is the case in the example above, then the **Paste Index'd CVs** button will also be enabled.

You can leave this Edit CVs window on the screen if you wish, when proceeding to the next stage, but it is probably safest to **Close** it now to avoid any mistakes when transferring the copied CVs into another Item.

Next, open the Edit CVs window for the Item which is to receive the copied CVs. This can be either an existing Item or, more usually, a new Blank Item which has just been created. If you have not already done so, carry out the basic initialisation of the Item (by setting its Type – as Locomotive, for example – and entering a Description), then reading in, and safely saving, a copy of the current decoder CV settings (just in case of any unfortunate accidents) as described in **Section 5.3**.

Now, *before* you change the recipient Item's Primary and Extended Addresses, click on **Paste Main CVs** in the Edit CVs window of that Item –

Item #28 - Addr 000 - Configuration Variables

Item Description: Colorado Southern 2-6-0 Mogul - LokSnd Select

Program CVs
Read/Verify CVs
Copy All CVs
Paste Main CVs
Paste Exten'd CVs
Paste Index'd CVs
Update Item
Close

Identity Config Speed Funct'n Pages SUSI

Item Type: Locomotive
Primary Address: 037
Extended Address: 0737
User Identifier #1: 000
User Identifier #2: 000
Manufac Version No.: 168
Manufacturer ID: 151

CV	0x	1x	2x	3x	4x	5x	6x	7x	8x	9x	10x	11x	12x
0	000	000	000	000	000	000	000	011	058	168	000	000	000
1	037	000	000	016	000	000	075	015	066	188	000	000	000
2	002	000	000	003	000	032	200	018	074	208	000	030	003
3	040	128	000	000	000	140	100	022	082	230	000	032	100
4	030	003	000	000	000	048	100	026	090	255	000	120	004
5	064	000	000	000	000	032	025	030	100	128	000	000	000
6	022	000	000	000	000	255	128	000	000	000	000	005	120
7	168	194	024	000	003	143	003	040	124	000	000	080	000
8	151	225	000	000	001	043	005	046	136	000	000	032	000
9	000	000	006	000	019	128	008	052	152	000	000	000	000

Callouts:
 - New Item Description (points to 'Colorado Southern 2-6-0 Mogul - LokSnd Select')
 - Click to paste the copied Base CV values into the new Item (points to '037')
 - Set Primary Address after Paste (points to '037')
 - Set Extended Address after Paste (points to '0737')

This action copies the values of CV1 to CV256 from the CV Copy Buffer into CV1 to CV256 of the new Item. The contents of the CV Copy Buffer are retained until replaced by a further Copy All CVs action, so the values can be copied to as many further Items as you wish.

While it is reasonably safe to copy the Main (Base) CV Page into an Item with any type of decoder, the Page still contains a large number of manufacturer-specific CVs as well as the standard NMRA-defined CVs, and you may experience some unusual responses if you copy such values into a decoder from a different manufacturer. It is highly recommended that you restrict copying to between Items which will be fitted with the same make, and preferably model, of decoder.

The same caution applies if you click **Paste Exten'd CVs**, which will copy the buffered values of CV257 to CV512 into the new Item, together with the Block of CVs specific to SUSI CVs, namely CV897 to CV1024. Having the SUSI CV values loaded into the A-Track Item will not cause any problems with decoders which do not support SUSI, since this range of CVs will only be transferred to the actual decoder if you select and Program them explicitly (see **Section 6.7**).

Returning to our example, you will note that, in the new Item, because we have not yet selected the Decoder Manufacturer (as we would normally have done as part of the Item initialisation), the **Paste Index'd CVs** button is currently disabled, even though the Indexed CV Pages were copied from the original Item.

Click on the **Pages** Parameter Tab, click on the **Specific Manufacturer** option button, and select **ESU LokSound** from the drop-down list as the Decoder Manufacturer (the same as the original source Item). If you now select one of the enabled Index Pages, and then click **Paste Index'd CVs**, you can see the copied Index Pages being transferred to the new Item -

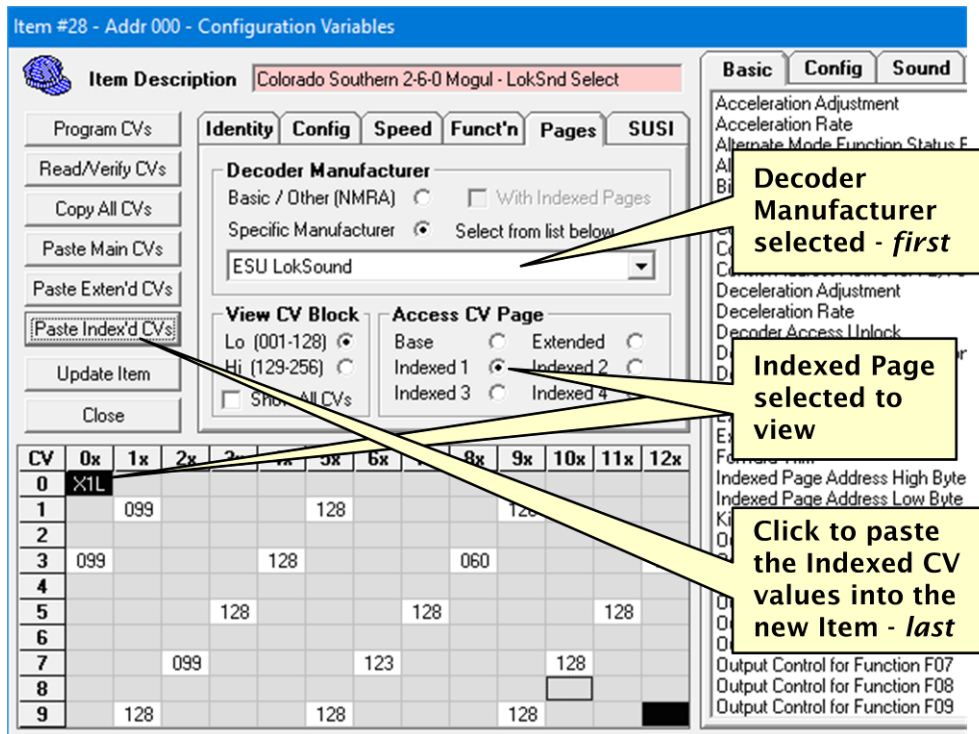

After copying the required set(s) of CVs into the new Item you can then proceed to make any further adjustments to its parameters, where necessary, such as under the Config Parameter Tab.

The key change of course, as already shown in the example, is to assign different Primary and Extended Addresses, by clicking in the relevant textboxes on the Identity Parameter Tab and typing the address values required for the new Locomotive. This is essential to ensure that the new Item can be uniquely identified within the Item List, particularly when allocated to a Controller.

Once this is done, you can click on **Update Item** to transfer the edited Item and its new parameters into the Item List -

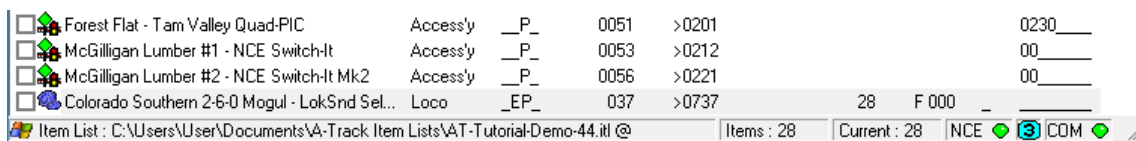

Finally, save the changed Item List to the PC's hard disk to ensure that the modifications are securely preserved.

6.6 Reading and Verifying CV Values

With the Program Track connected to the appropriate output from the NCE Command Station (Power Cab or Power Pro), placing a physical item (Locomotive) on the Track will allow you to read the current values of all, or of a selected subset, of the locomotive's DCC decoder Configuration Variables. Only a **single** locomotive should be present on the Program Track at any one time for correct Read/Verify operations.

This facility is used either to verify that new values programmed into the decoder have been received correctly, or, with a newly-acquired locomotive and/or decoder, to transfer the manufacturer's factory-set CV values (or the parameters programmed into the decoder using some other equipment, such as an NCE Handheld Cab) from the decoder to the corresponding A-Track Item in the Item List.

The latter operation is one you should *always* perform with a newly-acquired piece of DCC equipment, so that you know where you are starting from – and have a defined state you can get back to – before altering any of the decoder's CV values.

Note that, while using A-Track to read and verify a decoder's CVs, you should **not** simultaneously attempt to perform a similar operation (or **any** operation) using an NCE Handheld Cab, or you are likely to confuse the NCE Command Station.

Bear in mind also that, while the Program Track is active, the Mainline Track cannot be used. With the NCE Power Cab, which has only a single power output to connect to both Tracks, a switch to isolate the Mainline Track during Read / Verify and Program operations is recommended, as suggested in the connection diagram in **Section 1.1**. If you use the Mainline Track for Read/Verify (or Program) operations with an NCE Power Cab, ensure that no other locomotive is present on the track at that time. When using an NCE Power Pro Command Station, power is removed from the Mainline Track when the Program Track is operational.

Now double-click on the Item in the A-Track Item List that is intended to correspond to the locomotive on the Program Track (see **Section 5.3**). An Edit CVs window opens, displaying the current values of the Item's first 128 CVs in the CV Value Grid occupying the lower half of the window.

Before proceeding further, you need to ensure that the displayed Item contains the same number of CVs as the real decoder in your locomotive. Do this by clicking on the Pages Parameter Tab in the Edit CVs window and checking that the appropriate decoder Manufacturer has been selected or, if Basic / Other (NMRA) has been selected, that Indexed Pages have been enabled if required (see **Section 6.3**)

If you intend to access **all** of the CVs in one or more blocks then you can proceed directly to click the **Read/Verify CVs** Action Button and open the Read/Verify Configuration Variables page, as described in **Section 5.3**.

However, if you just wish to get the values of a subset of the CVs currently displayed in the CV Value Grid of the Edit CVs window, click on the first CV to be selected, hold down either **Shift** (↑) key, then click on the last CV in the group. The group of CVs, from the first to the last selected, will be highlighted with a **yellow** background. Note that selection is done in columns, running from top to bottom in each column, then moving rightwards to the next column.

Single CVs can be added to a selected group (which may just consist of one other selected CV) by clicking on the additional CV while either **Ctrl** (Control) key is held

down. Conversely, clicking on a selected CV while holding down either **Ctrl** key will deselect that CV and remove its background (**yellow**) highlighting.

After clicking on at least one cell in the CV Value Grid, you can also select all CVs in the displayed Grid by pressing **Ctrl-A** (hold down either **Ctrl** key then press the **A** key). You can then deselect any individual CV by clicking on its location while holding down either **Ctrl** key. Alternatively, you can first select those CVs you do *not* want in the final selection by using the mouse in conjunction with either **Ctrl** key, and then press **Ctrl-I** (either **Ctrl** key plus the **I** key) to invert the selection.

If you make an error in selecting a group of CVs, then simply click on any CV to remove the unwanted highlighting and leave only the CV on which you clicked highlighted. This last CV highlight can be removed by clicking on the highlighted CV while holding down either **Ctrl** key.

The example below shows a group of CVs selected by a click on CV01 followed by a click on CV46 with a **Shift** key held down, and then CV20 to CV26 removed from the selection by clicking on them in turn with a **Ctrl** key pressed. Before or after selection, a click on the **Read/Verify CVs** Action Button reveals the Read/Verify Configuration Variables page –

CV	0x	1x	2x	3x	4x	5x	6x	7x	8x	9x	10x	11x	12x
0	000	000	000	000	000	000	000	064	180	240	000	000	000
1	011	000	000	000	000	000	000	078	188	244	000	000	000
2	000	001	000	000	000	000	000	092	200	256	000	000	000
3	000	000	000	000	000	000	000	106	204	252	000	000	000
4	000	000	000	000	000	000	128	118	210	255	000	000	000
5	000	000	000	000	000	128	001	130	216	000	000	000	054
6	000	000	000	000	000	048	000	142	222	000	000	000	032
7	250	199	000	000	000	000	016	152	228	000	000	000	000
8	129	219	000	000	000	000	032	162	232	000	000	000	000
9	000	000	054	000	000	000	048	172	236	000	000	000	000

The **CV Range** options allow you to select either only the **Current View**, ie. the block of 128 CVs presently shown in the CV Value grid, or **All CV Blocks**, ie. the full complement of all CV Pages defined in the Item (with the exception of the SUSI block). Note that if you want to access a specific block of CVs other than that currently on view, then you will have to display that block from the Pages Parameter Tab *before* clicking the Read/Verify CVs Action Button – an example will be shown later. Within the selected CV Range, you can then choose a **CV Scope**, by clicking on the appropriate option button, of either **All CVs** or only those which are **Selected**, ie. are **highlighted (yellow)**.

You should also consider which decoder access **Mode** is to be used –

- **Paged** is the most common mode (and most likely to work correctly), but is also slow and may take up to 20 seconds to read the value of a single CV (Note that the NMRA term 'Paged' used here is completely unrelated to the CV Pages defined for the NMRA Indexed Addressing scheme)
- **Direct** is much faster, and is the preferred Mode, but is not supported by all decoders
- **Register** is similar to Paged, but only reads a very small subset of seven CVs, consisting of CV1 to CV4, CV7, CV8, and CV29
- **Address** is a legacy mode which only allows you to read the value of CV1

Click to select the required Mode, or leave it at the default setting of **Paged**.

For a first example of the Read/Verify operation, assume that no CVs are selected, CVRange and CV Scope are left at the default settings (Current View and All CVs), and that **Register Mode** has been selected, then click **Confirm** to start the Read/Verify operation –

The screenshot shows the 'Read/Verify Configuration Variables' dialog box for 'Item #6 - Addr 2011 - Configuration Variables'. The 'Mode' is set to 'Register'. An 'Egg Timer' icon is present, indicating an active operation. Below the dialog is a grid of CV values. Callouts explain: 'Egg Timer' to show operation in progress, Green highlight to show CV read is same as Item - or pink to show value is different, and Red highlight to show current CV read in progress.

CV	0x	1x	2x	3x	4x	5x	6x	7x	8x	9x	10x	11x	12x
0	000	000	000	000	000	000	000	000	000	000	000	000	000
1	003	000	000	000	000	000	000	000	000	000	000	000	000
2	000	001	000	000	000	000	000	092	196	248	000	000	000
3	000	000	000	000	000	000	000	106	204	252	000	000	000
4	000	000	000	000	000	000	128	118	210	255	000	000	000
5	000	000	000	000	000	128	001	130	216	000	000	000	054
6	000	000	000	000	000	048	000	142	222	000	000	000	032
7	250	199	000	000	000	000	016	152	000	000	000	000	000
8	129	213	000	000	000	000	032	162	232	000	000	000	000
9	000	000	054	000	000	000	048	172	236	000	000	000	000

During the Read/Verify operation, the CV currently being accessed will be highlighted in **red**. Once the CV value held in the decoder has been determined, it will be displayed in the grid and highlighted in **light green** if the value read is the *same* as that held in the Item, or highlighted in **pink** if it *differs* from the Item's stored value, as shown above.

Note the animated 'egg timer' icon being shown to indicate a currently active operation, and that all buttons other than **Cancel** are 'greyed-out' to prevent any interference with the Read/Verify process. Clicking **Cancel** will stop the Read/Verify operation eventually – in Paged or Register Modes this can take up to 20 seconds

(regardless of how many times you click the Cancel button) – but the value read from the currently accessed CV cannot then be relied upon to be correct.

Once the Read/Verify operation has been completed, a message is displayed to indicate the result -

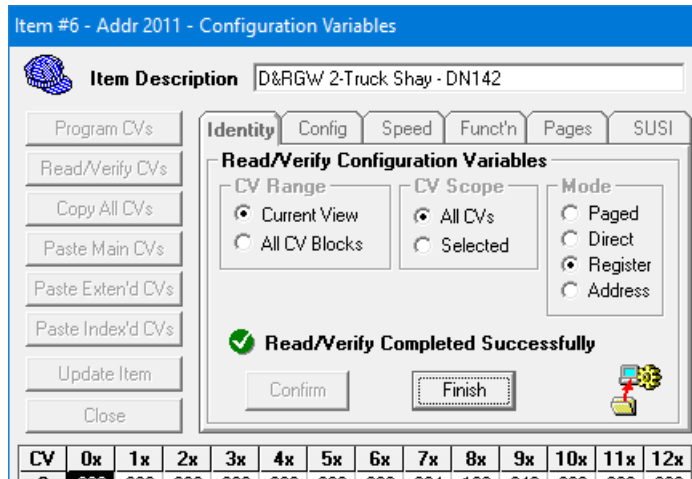

Click **Finish** to complete the Read/Verify operation. All highlighting of CVs will be removed except for those CVs where the value read from the decoder differs from that currently held in the Item. Such CVs will retain their **pink** highlight. Any CVs which were highlighted (**yellow**) before starting Read/Verify, but not accessed during the operation, will also retain their highlight.

If the Read/Verify operation fails for any reason then the value of the CV which could not be determined is set at zero, and indicated as a failure by 'striking-through' the digits (**000**).

Failure to complete the requested Read/Verify operation can be due to one or more of a number of causes –

- The Program Track is not properly connected to the NCE Command Station
- The locomotive is not in good contact with the Program Track, or the decoder wiring/connection is defective
- The decoder does not support the selected access Mode (particularly Direct)
- A **sound decoder** is fitted and is overloading the Program Track drive capability of a standard NCE Power Pro Command Station – a **programming booster unit** (such as the SoundTraxx PTB-100 or DCC Specialities PowerPax) requires to be inserted between the Command Station and the Program Track – such a unit is not generally required, *nor recommended*, when using an NCE Power Cab
- The decoder does not support the use of specific CVs and does not respond to Read/Verify commands when these CVs are accessed. This is a 'feature' of QSI Quantum sound decoders, for example, and, once you know which CVs are unsupported, you can omit these CVs from your selection in order to speed up the overall Read/Verify operation.

The Read/Verify operation continues with the next CV following any failure.

However, when an unexpected failure does occur (or for any other reason) you can stop the operation by clicking the **Cancel** button although, as noted previously, this can take up to 20 seconds in Paged or Register Modes (regardless of how many times you click the Cancel button).

In the example shown below, with a selected range of CV15 to CV35, Read/Verify has failed to read the values of CV30 and CV31, and has been halted by the user in the course of reading CV32 (for which the value shown may be incorrect), leaving the remainder of the selection (CV33-CV35) unread –

CV	0x	1x	2x	3x	4x	5x	6x	7x	8x	9x	10x	11x	12x
0	000	000	000	000	000	000	000	054	180	240	000	000	000
1	011	000	000	000	000	000	000	078	188	244	000	000	000
2	000	001	000	000	000	000	000	092	196	248	000	000	000
3	000	000	000	000	000	000	000	106	204	252	000	000	000
4	000	000	000	000	000	000	128	118	208	256	000	000	000
5	000	000	000	000	000	128	001	130	216	000	000	000	000
6	000	000	000	000	000	048	000	142	222	000	000	000	000
7	250	199	000	000	000	000	016	152	228	000	000	000	000
8	129	219	000	000	000	000	032	162	232	000	000	000	000
9	000	000	022	000	000	000	048	172	236	000	000	000	000

You can carry on with the Read/Verify operation from the *next* selected CV by clicking on **Continue**, when the Read/Verify operation will restart at CV33, continuing up to CV35. Click **Finish** to terminate the Read/Verify operation.

Following a failure of the Read/Verify operation, and after checking all of the Program Track electrical connections, and the contact between the locomotive and the track – in case the failure was due to some temporary condition – you can repeat the operation.

Either individually select each of the CVs where Read/Verify failed, and is indicated by 'strikethrough', or select any one and then press **Ctrl-L** (hold down either **Ctrl** (Control) key then press the **L** key), which will select all CVs marked by 'strikethrough', and then retry the Read/Verify operation with the **CV Scope** set at the **Selected** option.

Where a sound, or other, decoder uses CVs beyond the **Base Lo** Block that is normally displayed in the Edit CVs CV Value grid, you can select a CV Range of **All CV Blocks** for Read/Verify. Irrespective of the selected CV Scope (**All CVs** or **Selected**) A-Track will then proceed to step progressively through every (selected) CV value in each CV Block allocated to the Item.

Note, however, that this extensive Read/Verify operation will take an appreciable amount of time. In the case of ESU LokSound decoders, for example, the full operation will take around 30 minutes to complete when using Direct Mode, where each CV read requires 1 to 2 seconds. If you choose to use Paged Mode instead, the operation will potentially occupy several hours.

With QSI Solutions Quantum decoders, although Read/Verify takes up to 4 seconds per CV Value, because of the overhead of setting the Primary and Secondary Indexes before reading each value, the overall time to access all CV Pages in Direct Mode will only be around 45 to 50 minutes, because of the lesser number of CVs to access. Again, in Paged Mode, the operation will need several hours to complete.

However, the recommended way of using A-Track for Read/Verify operations (and for Program operations, as described in the following **Section 6.7**) is to handle a *single CV Block at a time*.

Hence, before starting the Read/Verify operation, click on the **Pages** Parameter Tab, and select the Block of interest using the **Access CV Page** and **View CV Block** options, as shown in the example below for an Item representing a locomotive with a QSI Solutions Quantum decoder –

The screenshot shows the 'Item #12 - Addr 089 - Configuration Variables' window. The 'Item Description' is 'Union Pacific Challenger - QSI Titan Steam'. The 'Pages' tab is active, showing 'Decoder Manufacturer' set to 'QSI Solutions - Quantum'. Under 'View CV Block', 'Lo (001-128)' is selected. Under 'Access CV Page', 'Indexed 2' is selected. A yellow callout box points to the 'Indexed 2' radio button with the text: 'CV Block to be Read/Verified selected before operation started'. Below the configuration options is a table of CV values:

CV	0x	1x	2x	3x	4x	5x	6x	7x	8x	9x	10x	11x	12x
0	Q2L	001	001	001	032	000	000	000	000	000	000	000	000
1	000	086	160	003	004	000	000	000	000	000	000	000	000
2	000	032	032	001	255	000	000	000	000	000	000	000	000
3	000	255	255	001	032	000	000	000	000	000	000	000	000
4				001		000		000		000		000	000
5	000	000	000	000	000	000	000	000	000	000	000	000	000
6	000	000	000	100	000	000	000	000	000	000	000	000	000
7		127	127		127		000		000		000	000	000
8	000	127	127		127		000		000		000	000	000
9	000										000	000	000

Ensure the locomotive is on the Program Track, then click the **Read/Verify CVs** Action Button and wait for the operation to complete –

Item #12 - Addr 089 - Configuration Variables

Item Description: Union Pacific Challenger - QSI Titan Steam

Program CVs
Read/Verify CVs
Copy All CVs
Paste Main CVs
Paste Exten'd CVs
Paste Index'd CVs
Update Item
Close

Identity Config Speed Funct'n Pages SUSI

Read/Verify Configuration Variables

CV Range: Current View All CV Blocks

CV Scope: All CVs Selected

Mode: Paged Direct Register Address

Confirm Cancel

CV	0x	1x	2x	3x	4x	5x	6x	7x	8x	9x	10x	11x	12x
0	Q2L	001	001	001	032	000	000	000	000	000	000	000	000
1	000	086	160	003	004	000	000	000	000	000	000	000	000
2	000	032	032	001	255	000	000	000	000	000	000	000	000
3	000	255	255	001	032	000	000	000	000	000	000	000	000
4				001		000	000	000	000	000	000	000	000
5	000	000	000	000	000	000	000	000	000	000	000	000	000
6	000	000	000	100	000	000	000	000	000	000	000	000	000
7		127	127		127		000	000	000	000	000	000	000
8	000	127	127		127		000	000	000	000	000	000	000
9	000										000	000	

Green highlight to show CV read is same as Item

Red highlight to show current CV read in progress

When all available or selected CVs have been read, exit the final Read/Verify operation by clicking **Finish**, then click **Update Item** to save the values retrieved from the decoder to the Item in the Item List. Finally, save the complete (changed) Item List to secure the information. This back-up philosophy ensures that you have an accurate record of the contents of the Item's decoder stored within the A-Track Item List, and should be regarded as an *essential* operation to record the original state of a newly-acquired locomotive decoder *before* you begin to make any changes or 'improvements'.

As a final note, if you do choose to read all CV Pages in a single operation from a complex sound decoder with an NCE Power Pro Command Station, you should be aware that this system (and its Serial Interface, in particular) was never designed to be used continuously for such extended periods, and it is highly likely that it will lock up at some stage, even when used in conjunction with a programming booster unit. This is usually indicated by a sequence of failed CV reads followed by one or both of the left- and rightmost Status Bar indicators changing to **yellow**.

In such cases, cancel the Read/Verify operation, then switch off the NCE Power Pro Command Station. Allow around 20 seconds for the Command Station to power down fully, then switch it back on – when A-Track should re-establish the connection. Only in exceptional circumstances should it be necessary to restart the A-Track program itself. Thereafter, with an NCE Power Pro system, the safer recommended strategy is to select and operate on only the single Block in view at a time.

The NCE Power Cab is much more robust in this respect, and can usually be relied upon to complete even the most extended Read/Verify operation. After clicking the **Read/Verify CVs** Action Button, it is probably safe to select **All CV Blocks** and **All CVs**, and leave A-Track to proceed.

6.7 Programming CV Values

Having set up, or changed, the required values of all or some of the CVs of an Item (such as the Primary or Extended Address), the next step, after saving a copy back to the Item List, is to transfer the new CV values to the actual DCC decoder. This can be done either on the Program Track (**Service Mode** programming) or on the Mainline Track (**Operations Mode** programming).

Operations Mode programming is useful to 'fine-tune' selected decoder parameters when a locomotive, for example, is running on the Mainline, having set up the majority of CV values for the decoder on the Program Track. However, unless you are using a sound decoder with verbal read-out of CV values, you cannot use Operations Mode to read back the programmed value and confirm that it has been set correctly.

Note that not all decoders (especially older models) support Operations Mode programming commands.

Be aware, also, that some decoders which do support Operations Mode programming will still not allow you to change Address values via Operations Mode (since the current decoder Address has to be included in the command to update a decoder CV value on the Mainline). In such cases, Address changes will have to be programmed on the Program Track – or by using some special, indirect Operations Mode method provided by the specific decoder manufacturer.

As noted in **Section 1.1**, and shown in the relevant system connection diagram, the NCE Power Pro has limited Program Track drive capabilities so that, particularly where sound decoders are fitted to your locomotives, it is strongly recommended that a programming track booster unit (such as the SoundTraxx PTB-100 or the DCC Specialities PowerPax) is inserted between the Command Station and the Program Track.

Once fitted the booster unit can be left permanently connected for programming and verifying all types of decoders. A programming track booster unit is not generally required when using an NCE Power Cab which has a comparatively higher drive capability in Program mode.

Note : Although, with the addition of an NCE Pro Cab, the NCE DCC Twin can be used to program all types of decoder, it is not designed for this purpose and does not incorporate the power-limiting Program Mode of either the NCE Power Pro or Power Cab systems. This means that decoders will effectively be programmed using the full power available for the mainline track. For decoders which are pre-installed, or already proved to be wired-in correctly, this should not be a problem but, if you are programming a decoder which has just been fitted, there will be no protection against wiring errors – which could result in the destruction of the decoder from excessive current (with acknowledgement to Mark Gurries for providing this information).

After opening up an Edit CVs window for the Item corresponding to the decoder to be programmed, the method of selecting which CVs to Program is the same as that used for the Read/Verify operation in **Section 6.6** above, and the same decoder access Modes are available.

As described for Read/Verify operations in **Section 6.6**, the recommended way of using A-Track for Program operations is to handle a *single CV Block at a time*, particularly when using an NCE Power Pro Command Station. Hence, before starting the Program operation (especially when accessing a decoder with Extended or Indexed

CV Pages), click on the **Pages** Parameter Tab, and select the Block of interest using the **Access CV Page** and **View CV Block** options.

With the locomotive to be programmed located on the appropriate Track (and the **only** locomotive present if using the Program Track and Service Mode), click on the **Program CVs** Action Button to show the Program options page.

Here, in addition to options to program All or Selected CVs, you can also choose to program only those CVs whose value has been Changed, ie. those currently highlighted within the CV Grid in **pink**. Note that whenever a changed CV is selected, its pink highlight will become **orange** (rather than yellow).

In the example below, programming of the decoder is set to be on the Program Track, in **Paged** Mode, of the **Selected** CVs from CV01 up to CV29 (highlighted in **yellow**). A 3-Step Speed Table has been set up under the Speed Parameter Tab (see **Section 6.1**) so that CV02, CV05 and CV06 will be shown as changed as well as being selected (**orange**). After clicking **Confirm** to start the Program operation, the Edit CVs window will look as shown below after a few seconds –

The screenshot shows the 'Configuration Variables' window for 'Item #11 - Addr 0464'. The window has tabs for 'Program CVs', 'Read/Verify CVs', 'Copy All CVs', 'Paste Main CVs', 'Paste Exten'd CVs', 'Paste Index'd CVs', 'Update Item', and 'Close'. The 'Program Configuration Variables' section includes options for 'CV Range' (Current View, All CV Blocks), 'CV Scope' (All CVs, Selected, Changed), and 'Mode' (Paged, Direct, Register, Address). A 'Program on Main Track' checkbox is also present. Below these options is a grid of CV values. Three callouts point to specific cells in the grid: a green highlight on CV01, a red highlight on CV04, and an orange highlight on CV05.

CV	0x	1x	2x	3x	4x	5x	6x	7x	8x	9x	10x	11x	12x
0	000	000	000	000	000	000	000	000	000	000	000	000	000
1	064	000	000	000	000	000	000	000	000	000	000	000	000
2	016	001	000	000	000	000	000	000	000	000	000	000	000
3	000	000	000	000	000	000	000	000	000	000	000	000	000
4	000	000	000	000	000	000	128	000	000	000	000	000	000
5	192	000	000	000	000	000	001	000	000	128	000	000	000
6	150	000	000	000	000	000	128	000	000	000	000	000	000
7	106	193	000	000	000	000	000	000	000	000	000	000	000
8	129	208	000	000	000	000	000	000	000	000	000	000	000
9	000	000	038	000	000	000	000	000	000	000	000	000	000

As can be seen, CV01 through CV03 have already been programmed successfully, so are now shown with a **light green** background, while CV04, which is currently being programmed into the decoder, is highlighted in **red**.

When programming of all selected (and/or changed) CVs is completed, they should all be highlighted in **light green** –

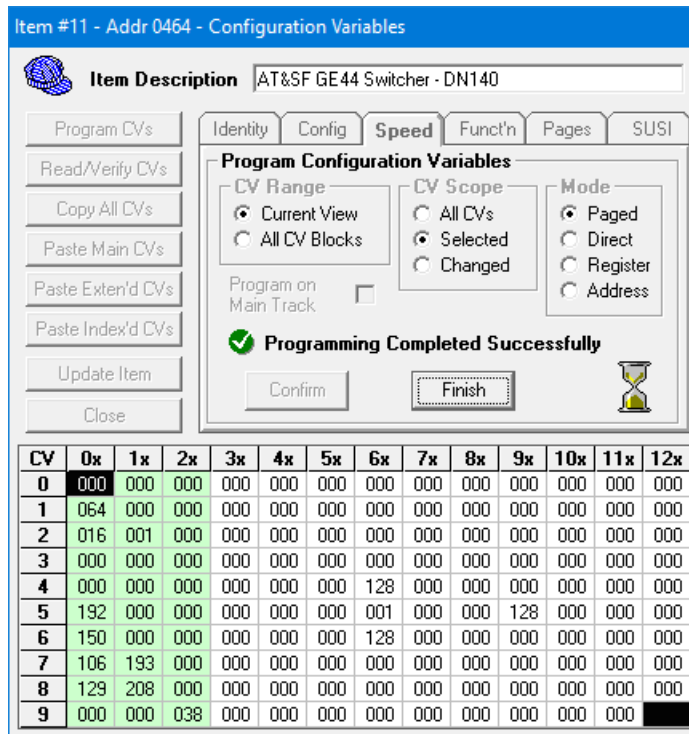

Note, however, that this, even together with the displayed message "**Programming Completed Successfully**", does not necessarily signify that the Program operation transferred the correct value to each of the highlighted CVs.

Acknowledgements that the decoder has accepted the value being programmed are only generated on the Program Track (when using Service Mode programming), but even here it is allowable, under NMRA Recommended Practices, for the Command Station to proceed to program the next CV regardless of whether any acknowledgement was received from the decoder.

No acknowledgements back to the Command Station are generated by the decoder when it is sent Operations Mode programming commands on the Mainline Track (although some decoders will still power the locomotive motor on for a brief period to show that a programming command was received).

The only completely reliable way to check that the decoder programming has been successful is to perform a subsequent Read/Verify operation on the Program Track.

Once the Program operation has completed fully, click **Finish** to close the process and return to display the previous Parameter Tab.

Important Note : Using "Keep-Alive" Units and Decoder Programming

Many decoders require their power to be cycled after Programming, ie. for power to be removed from the decoder for a short time and then restored, in order for the newly-programmed values to be applied to the relevant decoder CVs.

Hence, if you have a "keep-alive" unit (power storage capacitors) fitted to the Locomotive decoder, you need to switch off and leave the unit unpowered for a long enough time to allow the keep-alive capacitors to discharge completely (possibly a

few minutes) before attempting to Read/Verify or otherwise test the new decoder CV settings.

Programming on the Mainline Track is performed in exactly the same way as on the Program Track but, before clicking the Confirm button to start the operation, click the checkbox labelled **Program on Main Track** to place a tick in it. This will disable the Program Track access Modes.

The example which follows shows the Operations Mode programming of the decoder's Speed Table (CV67 to CV94) which has just been set up under the Speed Parameter Tab, so that the CVs are highlighted in **pink**.

As with Read/Verify, clicking **Cancel** at any time will stop the Program operation as soon as possible, displaying the appropriate status message, as shown in the result below –

Item #11 - Addr 0464 - Configuration Variables

Item Description: AT&SF GE44 Switcher - DN140

Program Configuration Variables

CV Range: Current View All CV Blocks

CV Scope: All CVs Selected Changed

Mode: Paged Direct Register Address

Program on Main Track:

Cancelled Program of Selected CVs

Continue Finish

CV	0x	1x	2x	3x	4x	5x	6x	7x	8x	9x	10x	11x	12x
0	000	000	000	000	000	000	000	062	150	185	000	000	000
1	064	000	000	000	000	000	000	075	155	187	000	000	000
2	016	000	000	000	000	000	000	087	160	189	000	000	000
3	000	000	000	000	000	000	000	097	164	190	000	000	000
4	000	000	000	000	000	000	128	107	168	192	000	000	000
5	192	000	000	000	000	000	001	116	171	128	000	000	000
6	150	000	000	000	000	000	128	124	175	000	000	000	000
7	106	193	000	000	000	000	016	132	178	000	000	000	000
8	129	208	000	000	000	000	033	138	180	000	000	000	000
9	000	000	050	000	000	000	048	144	183	000	000	000	000

'Program on Main Track' (Operations Mode) Selected

Green highlight to show Programmed OK - no highlight to show Cancelled

Pink highlight to show Changed CV - and not yet programmed

From this point you can resume the Program operation from the *next* changed (or selected) CV by clicking **Continue**, but note that the state of the decoder CV at which you stopped, in this case CV84, is indeterminate – it may or may not have been programmed with the Item CV value – so you may have check it later via Read/Verify, then use another Program operation to set its value correctly, if required. Alternatively, you can terminate all programming by clicking on **Finish**.

Although the Program operation itself does not change any of the Item's CV data stored in the Item List, it does clear the **Not Programmed** (P) Flag in the copy of the Item's parameters held within the Edit CVs window, as soon as you click on the **Finish** button, to indicate that the Item CVs have been transferred to a decoder.

If, at this stage, you click **Close** rather than **Update Item**, you will be prompted to save the changed Item parameters to the Item List.

Provided no changes were made to the Item other than transferring its contents to the real decoder, you can choose to ignore the save request. However, if any CV values were changed immediately prior to programming, and have not yet been transferred to the Item, you should definitely click **Update Item** at the end of the Program process to transfer the updated values to the Item entry in the Item List.

6.8 Control - Allocation of Locomotive Items

As well as providing facilities to edit Item parameters, when connected to an NCE Power Pro, Power Cab or Smart Booster Version 1.65, or a DCC Twin Command Station (but *not* earlier versions of Power Cab or Smart Booster), A-Track can also allocate specific Locomotive Items (including Consists and Multiples) to be controlled by any connected NCE Handheld Cab.

Although access to these functions is available via the **Item** menu, the more usual method is to use the **Pop-Up** menu which appears whenever an Item is **right-clicked**. The Pop-Up menu also contains selected options from the Edit menu for convenience (but note that, here, the functions apply *only* to the single Item which was right-clicked) -

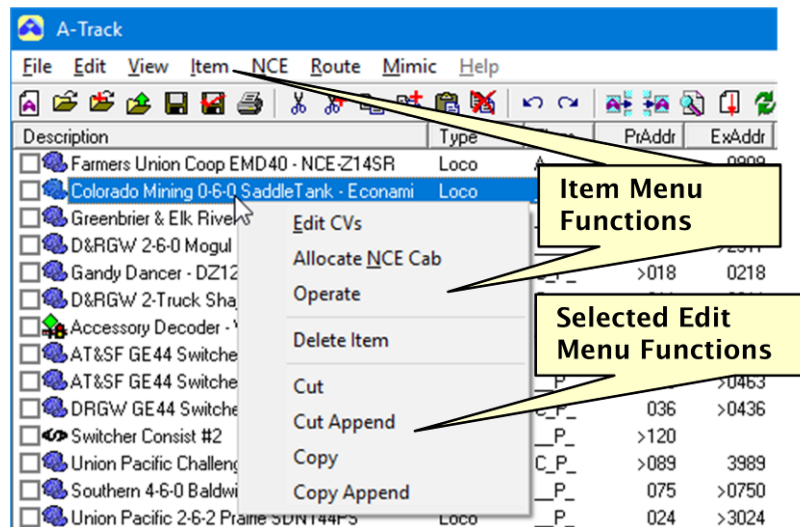

Clicking the **Edit CVs** entry on the Item or Pop-Up menus will open a new window which allows all of the Item's Configuration Variables and other parameters to be viewed, edited, and programmed into the real Item's DCC decoder. This is dealt with in detail in **Chapter 5**, and **Sections 6.1** to **6.7**.

The next entry, **Allocate NCE Cab**, opens a new window which allows the currently-selected Item (the one which has just been right-clicked) to be allocated to an NCE Handheld Controller (Cab) when using an NCE Power Pro, Power Cab or Smart Booster Version 1.65, or a DCC Twin Command Station. This menu entry will be 'greyed-out', and hence unavailable, when A-Track is connected to an earlier version of Power Cab or Smart Booster (or via a Version 6 NCE USB Interface).

As an example, suppose that the Loco Item on which you right-clicked was **Item #6**, the D&RGW 2-Truck Shay, followed by a click on the **Allocate NCE Cab** option on the Pop-Up menu.

The first time the Allocate NCE Cab function is invoked after loading an Item List, A-Track will read details from the NCE Command Station of the current allocations to the Cab with Address 02. You may notice a short delay before transfer of the Cab 02 data starts if a periodic scan of connected Cab status is currently in progress but, once the transfer begins, it is indicated by the normal **progress window** shown below. When the transfer is complete, the addresses of the locomotives and/or consists allocated to Cab 02 will then be displayed in the **Allocate Item to NCE Cab** window, also as shown below –

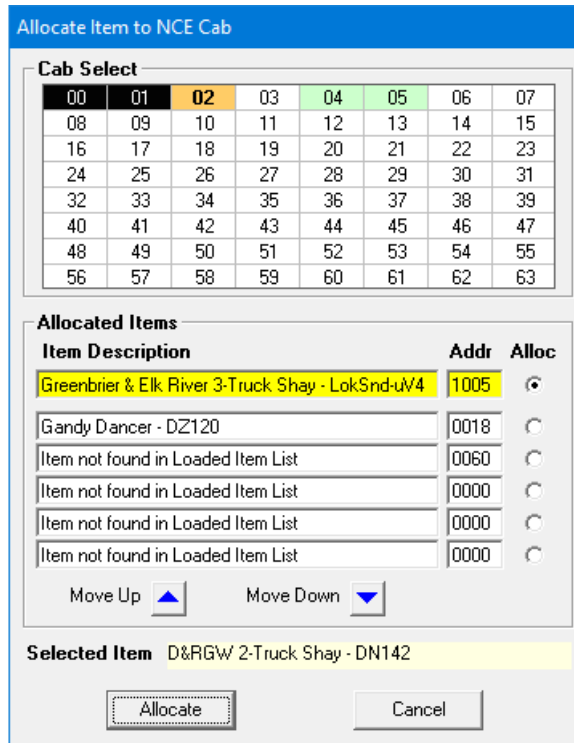
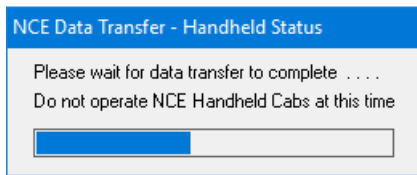

The NCE Command Station and Cabs only identify each loco and consist by their address (or, more accurately, by the address programmed into their DCC decoder which has been selected to be active, ie. Primary or Extended). However, where an address corresponds to that of an Item in the current Item List, A-Track will also display that Item’s Description in the Allocated Items list, as shown for the two currently-allocated locomotives in the lower part of the Allocate Item window.

The addresses of all Cabs which have been connected to the Command Station since it was switched on are highlighted, in the upper part of the Allocate Item window, with a **light-green** background. The Cab selected for Allocation of this Selected Item is highlighted with an **orange** background. All other Cabs which could be connected to the Command Station are shown with a white background – for the Power Pro Command Station used in the above example, all Cab addresses from 02 to 63 are available.

If you wish to allocate the **Selected Item** (D&RGW 2-Truck Shay) to any other NCE Handheld Cab (regardless of whether that Cab is, or has been, connected to the Command Station), then click on the address of that particular Cab in the Cab Select grid in the upper half of the window.

A-Track will then transfer the current allocation of locomotives or consists held for the selected Cab from the Command Station, and display them in the Allocated Items list. A-Track remembers the last Cab selection so that, the *next* time **Allocate NCE Cab** is clicked on the Item or Pop-Up menu, the allocated Items for that Cab will be fetched and displayed.

Clicking on Cab Address 04, for example, would result in the window contents shown below, where Cab 04 also has two locomotives allocated to it at present –

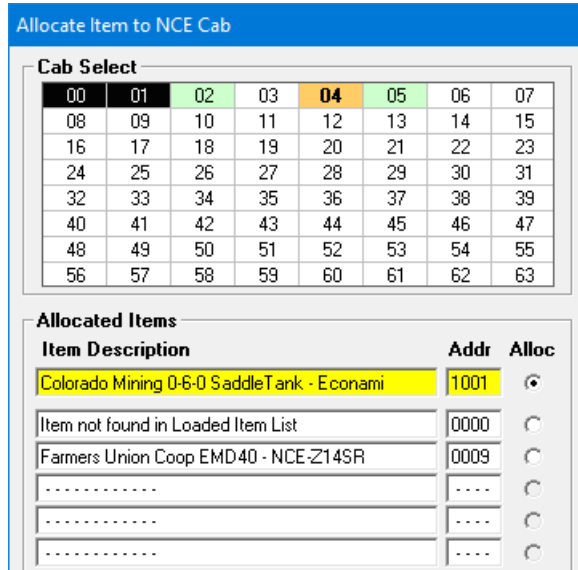

Having selected a particular NCE Cab, the next step is to select a suitable **'slot'** to which to allocate the selected Item that was originally right-clicked (or selected) in the Item List. The number of allocation 'slots' available is determined by the **Recall Depth** defined for the selected NCE Cab (see **Section 9.4**).

In the examples shown above, Cab 02 has a Recall Depth of 6, with 3 slots currently allocated (including one to a Locomotive with Address 0060 which is not in the loaded Item List), whereas Cab 04 has a Recall Depth of 3, with two of the available three slots allocated. The locomotive or consist shown in the topmost slot (Slot 1) of a Cab is the one which is under active control by that specific Cab.

Returning to the first example, showing the allocation status of NCE Cab 02, you can see that Slot 4 is currently unallocated, since it is shown with address 0000. Hence, this is the most obvious slot to which to allocate the selected Item. If no free slot is available, then you will have to choose one of the currently-allocated locomotives or consists to be replaced with the selected Item. Select a slot for allocation by clicking the **Alloc** option button next to the chosen slot, which is then highlighted in **yellow** –

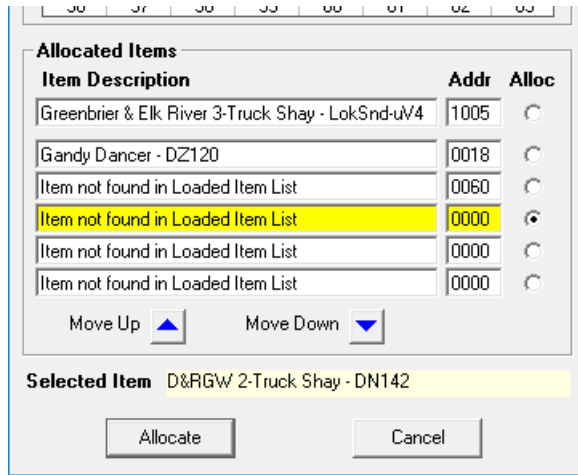

The choice of slot, at this stage, is not fixed, and can be changed simply by clicking any other **Alloc** button.

After choosing any slot you then have the option of using the **Move Up** and **Move Down** buttons below the allocation slots. Clicking the Move Up button transfers the Item in Slot 2 into Slot 1, with the Item in Slot 1 moving to the bottom slot (defined by the Recall Depth), with all intermediate Items moving up one slot.

Move Up achieves the same effect as pressing the physical **RECALL** button on an NCE ProCab Handheld Controller once Items have actually been allocated, but note carefully that, at this stage, moving Items from one slot to another has no effect whatsoever on the actual current allocations within the selected NCE Cab.

Move Down lets you rotate allocations in the opposite direction, eg. from Slot 1 to Slot 2, and thus acts like a reverse NCE ProCab RECALL button.

You can use the **Move Up** or **Move Down** buttons to move the contents of the selected slot to Slot 1, for example, so that, when you finally allocate the Item which was originally right-clicked on the Item List to the NCE Cab, it will become the locomotive or consist under active control by that Cab -

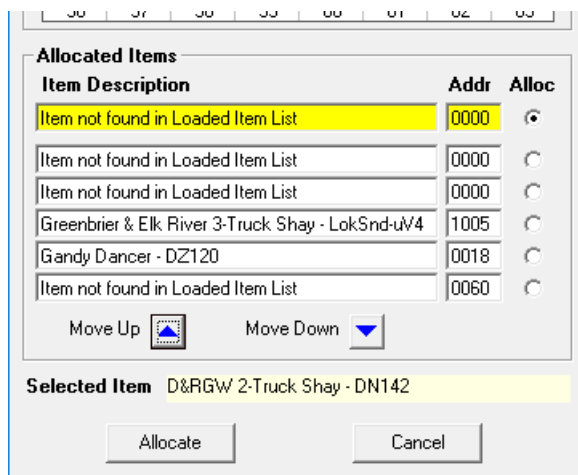

Once you are satisfied that you have picked the right slot, and that the Items are in the positions you want, click the **Allocate** button. The Address and Description of the Item to be allocated (shown above as Selected Item) is copied to the selected slot, and displayed against a **pink** background –

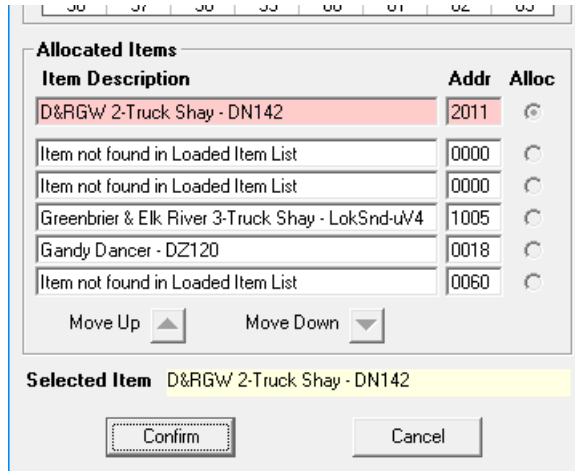

At this point the allocation and selected slot position are both 'frozen' and cannot be altered.

Click **Confirm** to transfer the new allocation of Items to the selected NCE Cab, or click **Cancel** to close the Allocate Item window without making any changes to the NCE Cab or to the Item List. Note that you can click Cancel at any time during the allocation process to abandon any changes, and return to the state before you clicked on the Allocate NCE Cab menu option.

Clicking on Confirm will display the following warning –

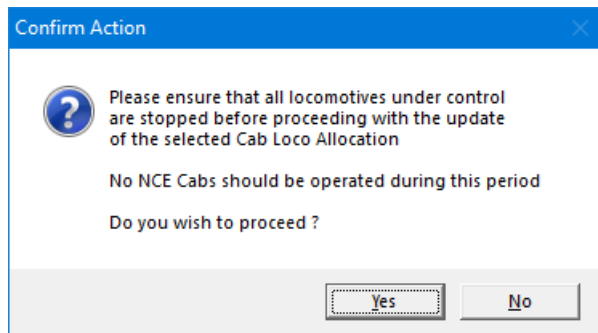

This gives you a further chance to abandon the complete allocation update, and your proposed changes, by clicking **No**. Alternatively, click **Yes** to proceed.

As stated in the warning message, you should ensure that all locomotives or consists are stopped before proceeding, and that no NCE Cabs are operating while the Command Station memory is updated with the desired allocations.

Following display of the normal NCE Data Transfer progress bar, a confirmation window will appear when the Cab allocation has been updated. Click **OK** to dismiss the confirmation notice, and the background to the list of Allocated Items will then change to **light-green** –

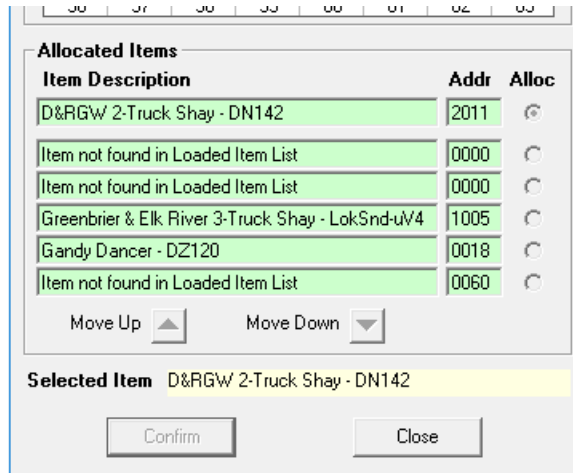
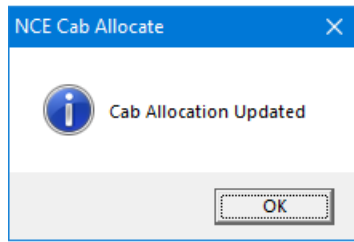

Click the **OK** button to remove the confirmation window, and then finally click **Finish** to close the Allocate Item window. The updated NCE Cab should now be ready to control the newly-allocated Item on the track, as well as the other locomotives and consists in its Recall list.

If you have changed the Item allocation to Slot 1 of an NCE ProCab then, with an NCE Power Pro system, you will see the address of the newly-allocated locomotive appear immediately on the ProCab display. However, with a Power Cab, Smart Booster, or DCC Twin system, you will need to press the ENTER key of the ProCab before its display will update.

Once the Item has been allocated to an NCE Handheld Cab (or to an on-screen Controller – see the following **Section 6.9**), the identity of the allocated Cab or Controller will appear in the **Controller** column of the Item List row corresponding to the Item under control.

The allocation of Item 'D&RGW 2-Truck Shay' to NCE Cab 02 in the preceding example is highlighted in the Item List segment shown below. Since this Item was allocated to Slot 1, thus setting the Item under active control, its **Allocation** Flag is set to '**A**', and the Controller is shown as **NC 02** (capital letters).

Two other Items ('Greenbrier & Elk River 3-Truck Shay' and 'Gandy Dancer') remain allocated to NCE Cab 02, as shown in the Allocate Items list above. Since these locomotives are in the Cab's Recall list, and not under active control at this time, the Allocation Flag is set to '**C**' and the Controller is shown as **nc 02** (small letters) –

Description	Type	Flags	PrAddr	ExAddr	Controller	SpSts	Speed	FL	Funct 1-8
<input type="checkbox"/> Farmers Union Coop EMD40 - NCE-Z14SR	Loco	C__	>009	0909	nc 04	28	F 000	-	_____
<input type="checkbox"/> Colorado Mining 0-6-0 SaddleTank - Econami	Loco	A__	001	>1001	NC 04	28	F 000	-	_____
<input type="checkbox"/> Greenbrier & Elk River 3-Truck Shay - Lok5n...	Loco	C_P_	005	>1005	nc 02	28	F 000	-	_____
<input type="checkbox"/> D&RGW 2-6-0 Mogul - TCS-MC6	Loco	___	017	>2917		28	F 000	-	_____
<input type="checkbox"/> Gandy Dancer - DZ120	Loco	C_P_	>018	0218	nc 02	128	F 000	-	_____
<input checked="" type="checkbox"/> D&RGW 2-Truck Shay - DN142	Loco	A__	011	>2011	NC 02	28	F 000	-	_____
<input type="checkbox"/> Accessory Decoder - Wangrow SM-104	Access'y	_P_	>0260	1037					1234__
<input type="checkbox"/> AT&SF GE44 Switcher - DN140	Loco	_P_	064	>0464		28	F 000	-	_____
<input type="checkbox"/> AT&SF GE44 Switcher - DN135D	Loco	_P_	063	>0463		28	F 000	-	_____

Note that any updates to NCE Cab allocations will not appear instantly in the Item List. Each connected Cab is scanned in turn, at 2-second intervals, and the Speed and Function settings of the active Item (the one in Slot 1 of the Cab) are transferred to the Item List. Hence, with three connected Cabs in the current example, you should see the Item List entry updated within 6 seconds.

The state of the Items in each Cab’s Recall List is not monitored continuously, but the complete status of all allocated Items can be updated at any time by clicking the **Refresh** (🔄) icon on the A-Track toolbar or by clicking **View** on the A-Track menu bar, and selecting the **Refresh Item Allocation & Status** option (See **Sections 3.5, 4.1, 9.4, and 12.3**). Whenever this is done, details of all NCE Cab allocations are cleared from the Controller column of the Item List, and the full scan of all NCE Cabs is initiated. The delay before the Controller column is refreshed will normally be less than 30 seconds, but could be considerably longer if a large number of Cabs are connected to the Command Station.

It is also important to note that, by using the normal NCE Handheld Cab controls, it is perfectly possible to allocate a specific locomotive to more than one NCE Cab. Provided one or both NCE Cabs hold that locomotive inactive within their Recall list, this need not cause a problem. A conflict will only arise if both NCE Cabs attempt to control the allocated locomotive at the same time.

Unfortunately, because of the limited communication which can be supported between A-Track and any of the NCE Command Stations, and the time taken to capture and update the display of NCE Cab allocations, A-Track cannot determine unambiguously that a possible allocation conflict may exist. Hence, A-Track simply reports the latest allocation of an Item to an NCE Cab of which it is aware.

If all Item allocations to NCE Handheld Cabs are made through A-Track, as described earlier in this section, then no allocation conflicts can arise, since A-Track only allows an Item to be allocated to a single Controller at a time.

Once an Item has been allocated to an NCE Cab, the Allocate entry on the Item menu when that Item is selected (and on the Pop-Up menu, when the Item is right-clicked) changes to **Deallocate**. The Operate option (see **Section 6.9** which follows) is also disabled, when that Item is selected or right-clicked -

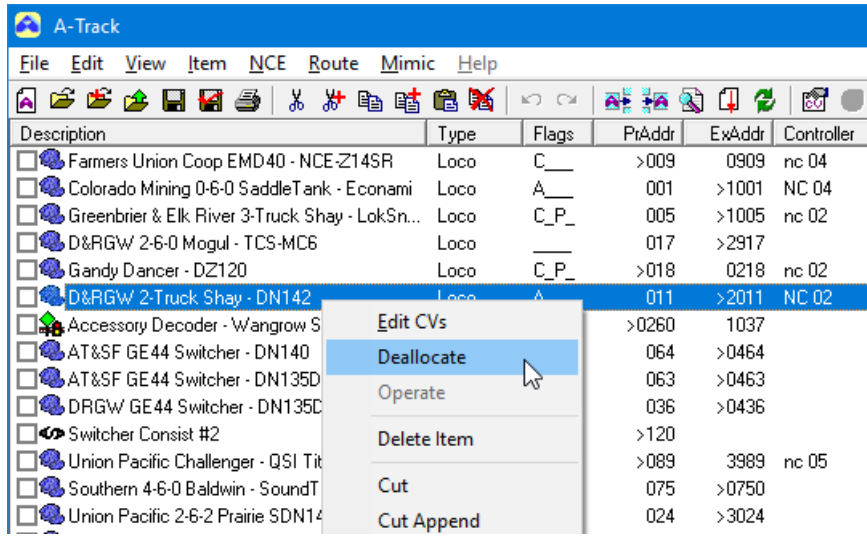

Clicking on the Deallocate option on either of the Item or Pop-Up menus, opens a **Deallocate Item from NCE Cab** window which is essentially the same as the Allocate Item to NCE Cab window shown previously. The current Cab and Item status is fetched by A-Track from the NCE Command Station and then displayed –

Deallocate Item from NCE Cab

Cab Select

00	01	02	03	04	05	06	07
08	09	10	11	12	13	14	15
16	17	18	19	20	21	22	23
24	25	26	27	28	29	30	31
32	33	34	35	36	37	38	39
40	41	42	43	44	45	46	47
48	49	50	51	52	53	54	55
56	57	58	59	60	61	62	63

Allocated Items

Item Description	Addr	Alloc
D&RGW 2-Truck Shay - DN142	2011	<input checked="" type="radio"/>
Item not found in Loaded Item List	0000	<input type="radio"/>
Item not found in Loaded Item List	0000	<input type="radio"/>
Greenbrier & Elk River 3-Truck Shay - LokSnd-uV4	1005	<input type="radio"/>
Gandy Dancer - DZ120	0018	<input type="radio"/>
Item not found in Loaded Item List	0060	<input type="radio"/>

Move Up Move Down

Selected Item D&RGW 2-Truck Shay - DN142

If the Item selected for deallocation is still under active control then the window is immediately closed, and the warning shown below is displayed in its place –

Item Under Control

Speed / Function Commands Active

Stop Item and Disable Functions before Attempting Deallocation of Item

Click **OK**, then follow the normal sequence of NCE Cab actions to bring the Item to a halt, and to deactivate any function switches, before attempting to Deallocate the Item again.

Otherwise, the Deallocate window will be displayed as shown above, with the selected Item highlighted with a **pink** background, but with all controls other than the **Confirm** and **Cancel** buttons disabled.

Click **Cancel** to abort the deallocation operation (leaving the Item still allocated), or **Confirm** to deallocate the Item from the Cab. After the new Cab allocation data is transferred to the NCE Command Station (in exactly the same way as previously

described for allocating an Item to a Cab) click **OK** to dismiss the confirmation notice, and the operation ends with the revised Allocated Items list highlighted in **light-green** as shown below –

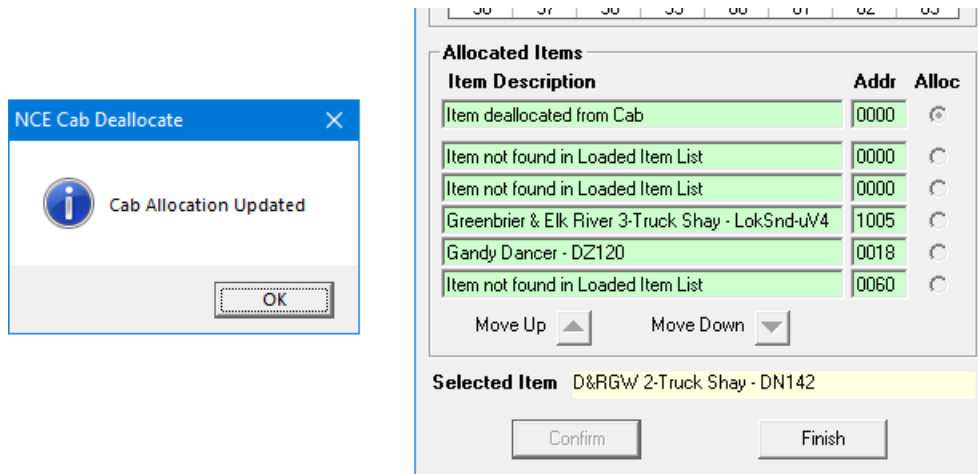

Click **Finish** to complete the deallocation process.

When using an NCE Power Cab Version 1.65 as the Command Station, only Cab addresses from 02 to 05 are available for use. Hence, all higher addresses are 'greyed out' so they cannot be selected for locomotive allocation, as shown below –

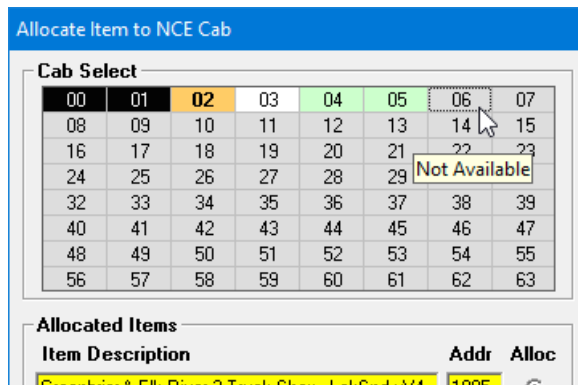

Allocate and Deallocate operations using a Power Cab are otherwise exactly the same as for the Power Pro Command Station used in the examples described previously. This is also the case when using a an SB5 (or updated SB3a) Smart Booster V1.65 Command Station, although now Cab addresses 06 and 07 are also available for allocation.

The DCC Twin Command Station has two in-built, basic Cabs (Throttles A and B) which use Cab addresses 00 and 01, respectively. Any additional NCE ProCabs linked to a DCC Twin can use addresses 02 to 07 so that the **Allocate Item to NCE Cab** window will appear as below –

Allocate Item to NCE Cab

Cab Select

00	01	02	03	04	05	06	07
08	09	10	11	12	13	14	15
16	17	18	19	20	21	22	23
24	25	26	27	28	29	30	31
32	33	34	35	36	37	38	39
40	41	42	43	44	45	46	47
48	49	50	51	52	53	54	55
56	57	58	59	60	61	62	63

Allocated Items

Item Description	Addr	Alloc
Item not found in Loaded Item List	0004	<input checked="" type="radio"/>
.....	<input type="radio"/>
.....	<input type="radio"/>
.....	<input type="radio"/>
.....	<input type="radio"/>
.....	<input type="radio"/>

Move Up Move Down

Selected Item D&RGW 2-Truck Shay - DN142

Each of the DCC Twin Cabs 00 and 01 have only a single allocation slot (no Recall list), so the locomotive to be allocated will replace the default locomotive (address 0004), as shown above, when the **Allocate** button is clicked.

Although the **NCE Power Pro Command Station** retains the current allocations of locomotives to Handheld Cabs when it is switched off (assuming that its internal backup battery is in good condition), together with their speed and function settings, this is **not** true of the **DCC Twin, Power Cab, or Smart Booster** when these allocations are made through A-Track. The latter Command Stations will only retain those locomotive allocations made using the NCE Cab control buttons, and these take precedence over any subsequent allocations made with A-Track. A-Track allocations **may** be retained after switch-off if no previous allocations have been made directly with the Cab controls, but this **cannot be guaranteed**.

Because of this deficiency in Version 1.65 and DCC Twin systems, A-Track incorporates a facility, as described later in **Section 9.1**, to save the complete status of these Command Stations as a backup file on your computer's hard disk, and to restore this status, including locomotive allocations, automatically when A-Track and the associated Command Station are next switched on.

When you save a copy of the Item List, using **Save As** or **Save Checked** from the **File** menu, A-Track will save all details of the Items in the current List, *with the exception* of their allocated Controller and their current speed and function values. This is also true if you simply close A-Track without having changed any of the 'permanent' Item parameters.

Subsequently, when you open A-Track again, and load an Item List, all Item allocations, plus speed and function settings, will be blank. If connected to an NCE Power Pro Command Station, A-Track will then proceed to load the locomotive

allocations relating to the NCE Handheld Cabs from the Command Station, and to display them against corresponding Items in the Item List (if such Items are present).

However, if using a Version 1.65 Power Cab or Smart Booster as Command Station, or a DCC Twin system, and automatic restore is selected, A-Track will first update the Command Station status and allocations before transferring them, as appropriate, to the Item List. Without automatic restore enabled, A-Track will simply load whatever locomotive allocations have been made previously with the NCE Cab controls – not necessarily those made earlier using A-Track.

6.9 Control - Direct Operation of Locomotive Items

The last option available on the **Item** (or **PopUp**) menu, **Operate**, allows control of individual Locomotive Items (including Consists and Multiples) from the PC screen, as long as those Items are not currently allocated to an NCE Handheld Cab.

Note that, when you right-click on an Accessory Item, the Operate option on the PopUp menu will open a different window to that shown below, with functions appropriate to control of Accessories, as described later in **Section 7.4**.

The Operate function opens a new window on the screen in the form of a 'soft controller' with which, by using the mouse, you can toggle 'switches' (**on** or **off**) or press 'pushbuttons' (momentary **on**) to control the state of the Item's functions, FL (Headlight) and F1 through F8 -

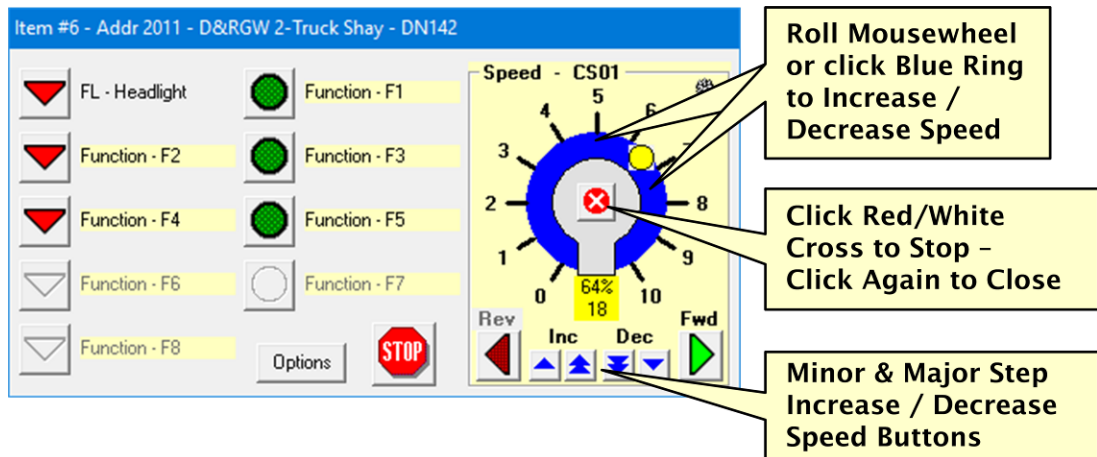

You can also 'rotate' the speed 'control knob' by rolling your mousewheel forwards or backwards, or by clicking on the blue ring either side of the small yellow disc on the blue background. The maximum amount by which the speed can be changed with each click on the blue ring is limited, to prevent you going directly from stationary to maximum speed, or *vice versa*. If you click closer to the small yellow disc than the set maximum step, then the disc will move to the point clicked, adjusting the Item's speed accordingly. Alternatively, if you prefer, you can click on any of the four speed buttons to increase or decrease Item's speed in defined steps.

The Item's speed is shown in the textboxes below the 'control knob' as both a percentage of the maximum speed and in speed steps. Note that, once the 'control knob' is active (yellow disc highlighted), speed can also be controlled from the

keyboard by using the keys listed below to increment or decrement it in small or larger steps, providing the same functions as the four, on-screen speed buttons –

Ctrl-UpArrow or U	▲	PageUp or I	▲▲
Ctrl-DownArrow or D	▼	PageDown or S	▼▼

A number of keys can also be used as an alternative to a left-click on the various Function buttons present on the 'soft controller', including the Direction 'switches' which allow you to change the Item's direction of travel from Forward to Reverse, or *vice versa* –

F	Forward (Fwd ▶)	R	Reverse (Rev ◀)
X	Stop / Close (⊗)		
L	FL - Headlight	1 - 8	Functions – F1 to F8

As well as the normal **Stop** button (⊗) there is also an **Emergency Stop** button (⊛) which, when clicked, will bring the Item to an immediate halt – which can also be done by pressing the **Pause/Break** key on the keyboard (see **Section 6.10**).

When the state of an Item function is changed, by clicking on a 'toggle switch' or 'pushbutton', you get visual feedback that the action has been recognised, as shown below –

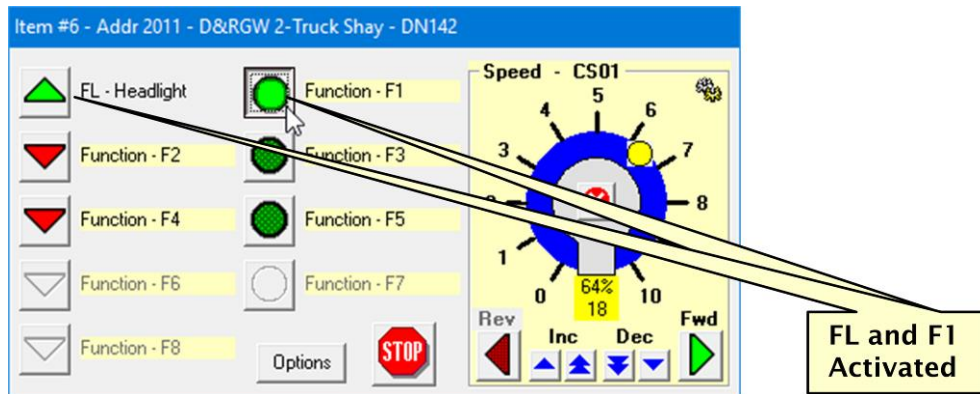

The behaviour of the function 'switches' and the speed 'control knob' can be programmed to suit the requirements of the Item and your personal preferences. To adjust the settings, first stop the Item by clicking on the red/white cross (⊗) in the centre of the speed 'control knob', then click on the **Options** button. If you click Options without first stopping the Item, then you will receive a warning –

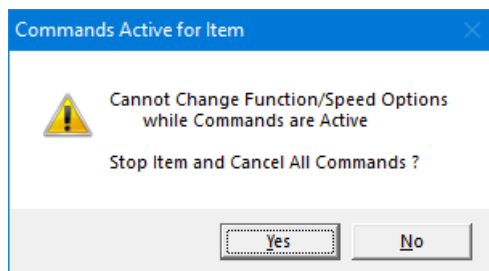

Click **Yes** to continue, or **No** to abandon the action, leaving the controller settings unchanged.

With the Item stopped, and all functions inactive, the Operate window changes to reveal the options which are available for you to customise –

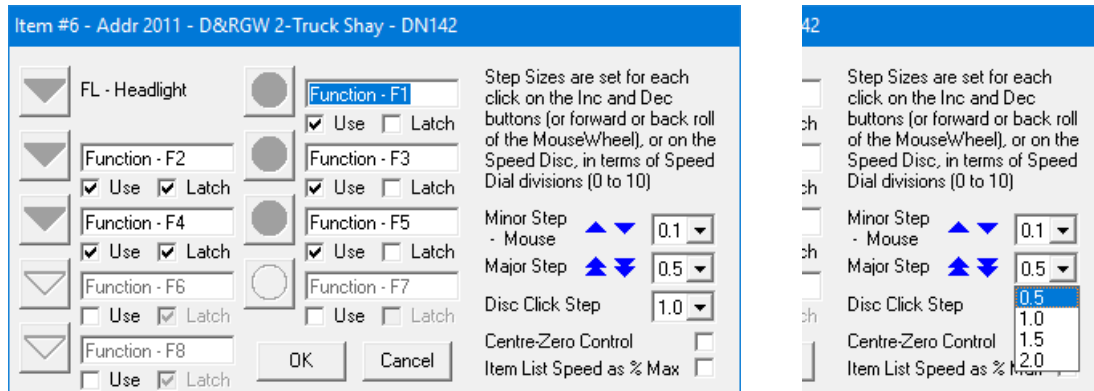

Each function 'switch' can be enabled (or disabled) by ticking the **Use** checkbox (by default, F1 to F5 are enabled), and can be made to act as a toggle switch by ticking the **Latch** checkbox, ie. it changes from off to on, or vice versa, each time it is clicked (by default F2 and F4 are set as latched). With the Latch checkbox unticked, the 'switch' behaves as a 'pushbutton', ie. when clicked it only stays on as long as the left mouse button is held down, otherwise it returns to the off state.

You can also change the **caption** for each switch from the default Function names, as shown, to any description which you will find more meaningful. Just click in the relevant textbox, to highlight the current name (as shown for 'Function - F1' above), and then type in your own title. Note that **FL**, the Headlight function, is always operated by a toggle switch and cannot be reprogrammed as a pushbutton nor renamed.

The amount by which you change the Item's speed when rolling the mousewheel or by clicking on any of the Minor or Major Step buttons, or on the blue 'speed' ring, can be adjusted by clicking on the down-arrow (▼) at the righthand end of any of the three listboxes, and then clicking on whichever value you would like from the drop-down lists, as shown above on the right.

Step values are given in terms of speed 'control knob' divisions, with available values as follows –

Mousewheel / Minor Step	0.1, 0.2, 0.3, 0.4
Major Step	0.5, 1.0, 1.5, 2.0
Disc Click Step	1.0, 1.5, 2.0, 2.5

The speed 'control knob' can be set to operate as a **centre-zero control** by ticking the appropriate checkbox, and you can choose whether the Item's speed, shown in the Speed column of the Item List, is displayed as a number of **speed steps** or as a **percentage** of the maximum speed (both versions are shown below the 'speed knob' of the controller itself).

An example with Function **F1** set to operate as a toggle switch for the **Bell**, Function **F2** set as a pushbutton to sound the **Whistle**, Function **F5** taken out of use, the Minor Step / Mousewheel value left at **0.1** divisions, the Major and Disc Click Steps also left at **0.5** and **1.0** division, respectively, and the Speed knob set for **centre-zero** operation, is shown below –

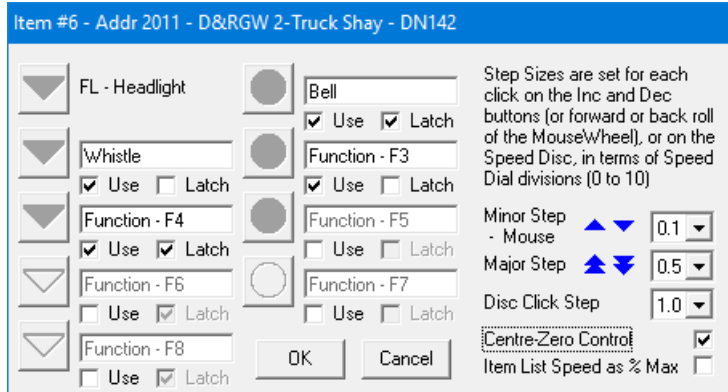

Once all the controls are set as required, click **OK** to return to an operational mode with the 'new' set of controls, or **Cancel** to abandon all of the changes. If the new settings are retained, the 'soft controller' will appear as shown below –

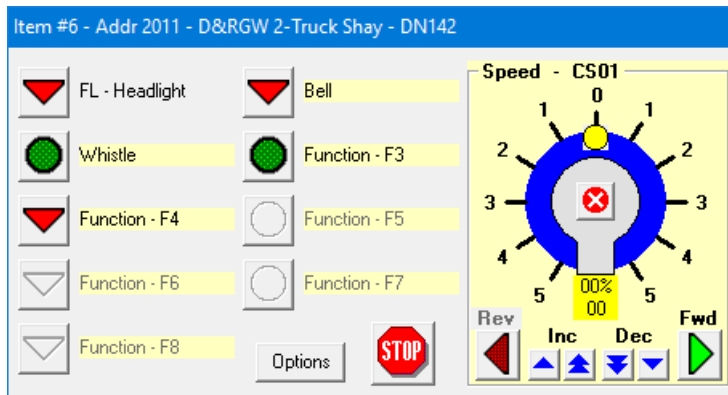

The revised settings will be stored as part of the Item's parameters if you choose to save them when you cease using this Operate 'soft controller' (see below).

When an Item is being operated using an A-Track 'soft controller', its status is shown in the Item List, as in the example below. Here, the Item allocation is shown in the Controller column as **CS 01**, with a forward speed of **F 018**, and the status of **FL** (Headlight) and Function **F2** both indicated as **on** –

Description	Type	Flags	PrAddr	ExAddr	Controller	SpSts	Speed	FL	Funcnt 1-8
Farmers Union Coop EMD40 - NCE-Z14SR	Loco	C__	>009	0909	nc 04	28	F 000	-	_____
Colorado Mining 0-6-0 SaddleTank - Econami	Loco	A__	001	>1001	NC 04	28	F 000	-	_____
Greenbrier & Elk River 3-Truck Shay - LokSn...	Loco	A_P_	005	>1005	NC 02	28	F 000	-	_____
D&RGW 2-6-0 Mogul - TCS-MC6	Loco	___	017	>2917		28	F 000	-	_____
Gandy Dancer - DZ120	Loco	C_P_	>018	0218	nc 02	128	F 000	-	_____
D&RGW 2-Truck Shay - DN142	Loco	A__	011	>2011	CS 01	28	F 018	L	_2_____

When using **centre-zero** operation, and with the direction set as **Fwd**, moving the 'speed knob' clockwise from zero moves the Item forward, while moving anticlockwise from zero results in reverse movement. These actions can be reversed by setting the direction as **Rev**, as shown in the examples below, where the **Speed** column in the Item List always shows the Item's *actual* direction of movement –

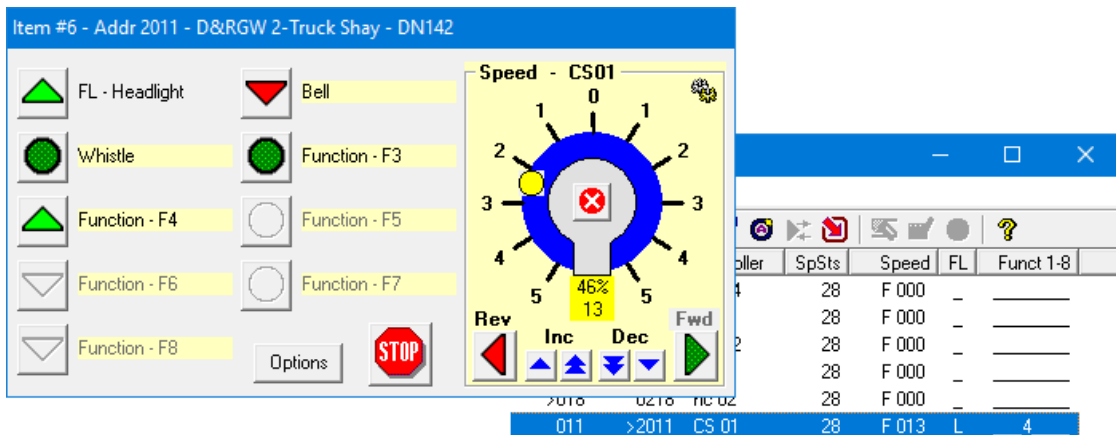
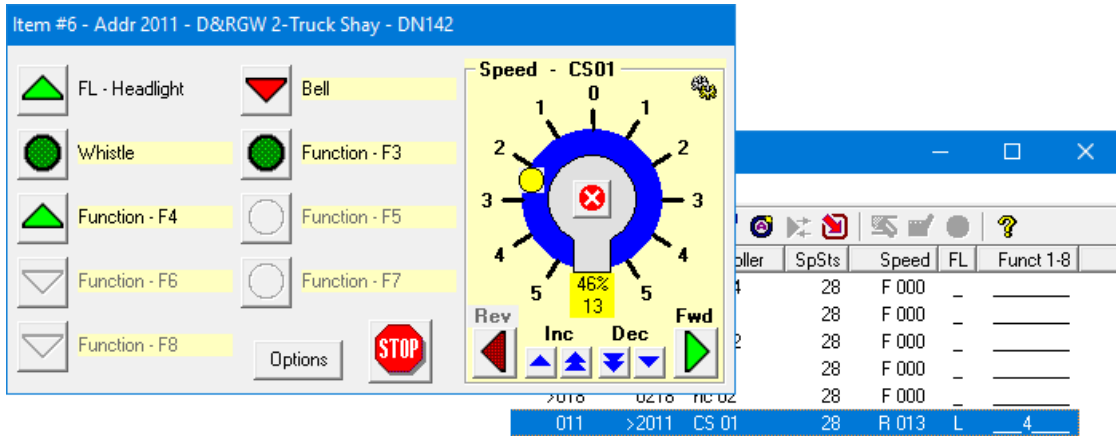

While using one or more Operate 'soft controllers', whose Item's status is updated in the Item List immediately they issue a command to the NCE Command Station, A-Track continues to monitor the status of all connected NCE Cabs, polling one approximately every two seconds.

However, when using an NCE DCC Twin as the Command Station, the monitoring of the DCC Twin in-built Throttles (Cabs 00 and 01) is suspended since, because of a quirk in the DCC Twin's internal memory structure, reading status takes such a long time that it interferes with the output of operational commands. Hopefully, this deficiency will be fixed in future versions of the DCC Twin. Once all Operate windows are closed, monitoring of Cabs 00 and 01 will resume automatically.

To exit from the Operate function, first switch all functions off, then stop the Item either by using the on-screen or keyboard controls to reduce its speed to zero, or by clicking the red/white cross (X) in the centre of the control knob. A further click on the red/white cross will then close the Operate window – with a prompt to save the control settings within the Item, if they have been changed –

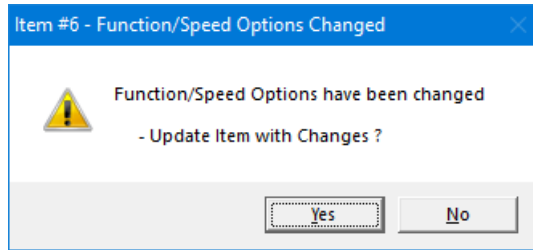

Two final points to note in connection with the control of Items directly from A-Track are that, firstly, while any Item is being operated from the screen, you *cannot change or edit the Item List*. All relevant File menu options, such as New, Open, and Close, and the complete Edit menu, are disabled until you cease direct Item control and close all Operate windows.

Secondly, if you attempt to close the complete A-Track program while Items are still under the control of a 'soft controller', then a warning will be displayed –

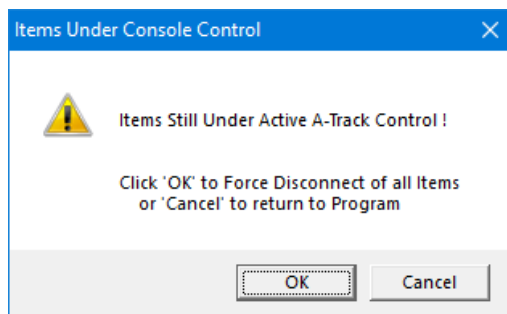

Clicking **Cancel** will return you to A-Track, with the opportunity to stop and deallocate the Items still under control, or you can click **OK** to force an immediate stop and disconnection of all Items.

The latter operation is performed by issuing an **Emergency Stop** via the NCE Command Station (see **Section 6.10** below), followed by a short **disconnection**, then reconnection, of mainline track power, before the A-Track program is finally closed. This is a rather brute-force way of shutting things down, and it is recommended that you adopt a more orderly approach, closing any open Operate windows individually before closing A-Track itself.

6.10 Emergency Stop

The last control in the Operate window, which was not dealt with in the previous section, is the **Emergency Stop** button which, when clicked, activates an Emergency Stop of the Item under control, cancels all active function 'switches', and sets the speed 'control knob' to zero. You can also activate an Emergency Stop by pressing the **Pause/Break** key on the **PC keyboard** (usually located, on a standard keyboard, as one of the rightmost keys of the top row of keys, ie. the row which contains the Function keys F1 to F12).

A **Stop** icon (🛑) replaces the normal **Active** indicator (🟢) in the top-righthand corner of the Operate window, as shown below –

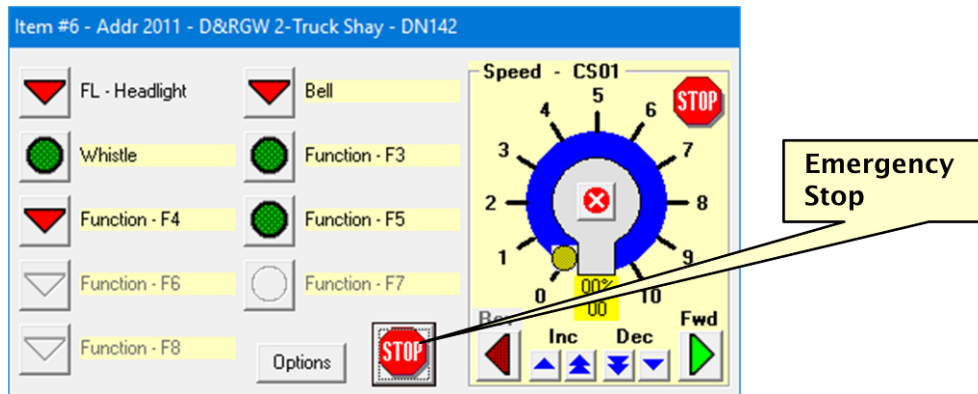

Any subsequent click on a function 'switch' or 'pushbutton', or movement of the speed 'control knob' will cancel the Emergency Stop of the Item, and remove the Stop icon.

However, a **second** click on the Operate window **Emergency Stop** button of the stopped Item (or of the **Pause/Break** key on the PC keyboard) will apply an Emergency Stop to **all Items** currently on the mainline track, by stopping the output of all normal DCC commands from the NCE Command Station, then replacing them with a set of *Emergency Stop* commands.

The sequence of Emergency Stop actions executed by A-Track depends on the type of Command Station connected between the PC and your layout. If you are connected to an **NCE Power Pro** Command Station, A-Track will first cut power to the track momentarily, in order to clear any current DCC commands being sent by the Command Station, and will then broadcast *Emergency Stop All* commands continuously for a period of about 4 seconds. Additionally, an advisory message '**AT-E'STP**' is sent to the LCD display of all attached NCE ProCabs by A-Track to make all operators aware of what has happened, together with a warning message displayed on the PC screen –

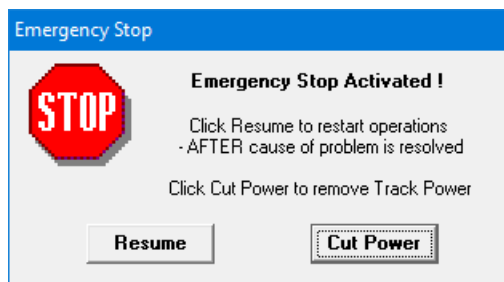

Clicking on **Resume** cancels the Emergency Stop of all Items, although each Item will remain stationary on the track until a new speed command is sent from the Controller (NCE Cab or Operate 'soft controller') to which that Item is allocated.

Note that Items under the control of an NCE Cab can be restarted as soon as the string of *Emergency Stop All* commands finishes, and without the Resume button being clicked, although it would be sensible to check on why an Emergency Stop was activated before continuing with track operations. The A-Track advisory message can be removed from the LCD display of any NCE ProCab by pressing that Cab's **ENTER** key.

If, instead of clicking Resume, you click on **Cut Power**, you will disable all output to the mainline track from the NCE Power Pro Command Station – effectively applying a permanent Emergency Stop to all Items (the Command Station is placed in Program Mode, so only the Program Track is powered). In this case the Emergency Stop cannot be cancelled through any action by an NCE Cab, but only by A-Track. An indication of this state is displayed on the PC screen as shown below –

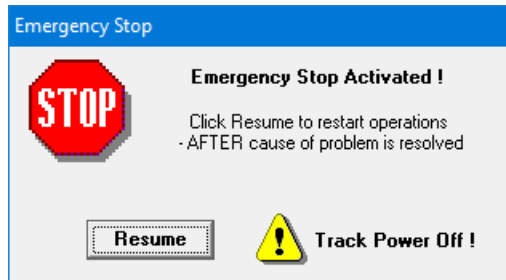

Again, click **Resume** to continue main track operation, but note that all Items on the track will still remain stationary until they receive another speed command from the controller to which they are currently allocated (NCE Cab or Operate 'soft controller').

Important : A-Track can only activate an Emergency Stop of Items on the track if it is connected to the NCE Command Station via a Serial or USB port, and the Command Station is powered on and communicating with A-Track.

Since the Operate function is only enabled on the Item or PopUp menus when the Serial or USB Interface and the NCE Command Station are connected and operational, it is unlikely that the following situation will arise, but is included for completeness. If, when an Operate window is open, and either the Serial or USB connection has been removed, or is not communicating with the Command Station then, if you click on the Emergency Stop button, the action will have no effect, and the following response to the Emergency Stop may be displayed –

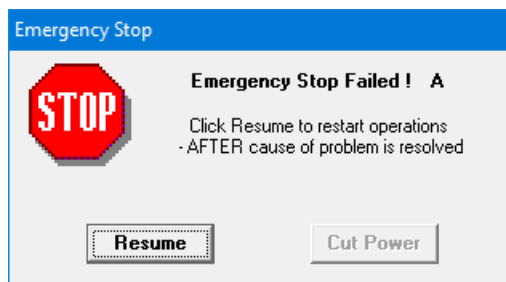

Since there is no active connection to the NCE Command Station, it is obviously not possible to request removal of power from the mainline track, so the Cut Power button is disabled in this case.

If you are using an **NCE Power Cab, Smart Booster, or DCC Twin** as your Command Station, then the Emergency Stop sequence in response to a **second** click on the Operate window **Emergency Stop** button of the stopped Item is a little different, because of two features which these systems lack –

- (1) The *Emergency Stop All* broadcast command is not supported by the NCE USB Interface – so cannot be sent to the Command Station

- (2) Power cannot be removed permanently from the Main Track – it can only be interrupted briefly when switching between Main and Program Modes. However, this can **only** be done if you are using either a Power Cab or a DCC Twin system, since it is **not possible** with a Smart Booster system which does not support Program Mode.

Hence, when used with Power Cab type systems, A-Track will first output a series of individual *Emergency Stop* commands to each Locomotive of which it is aware. If you have a Version 1.65 system then the set of Locos will include those allocated to each connected NCE Cab together with any being operated via a 'soft controller'. However, since Version 1.28 systems do not allow A-Track to access the NCE Cab allocations, such systems can only attempt to stop all Locos allocated to a 'soft controller'. The warning message displayed will be as shown below –



The *Emergency Stop* commands are issued to each identified Locomotive at a rate of about 3 per second, so there will be a noticeable delay before all these Locos are brought to a halt. Any other Locos will not be affected, so the next action is to change the Command Station output to Program Mode for about 4 seconds (Power Cab or DCC Twin systems **only**). As well as stopping the output of all DCC commands, this causes a brief interruption of power to the track when changing to Program Mode, followed by a further short break when returning to Main Mode – which should bring all Locos to a stop. When this sequence is complete, a further message is displayed –

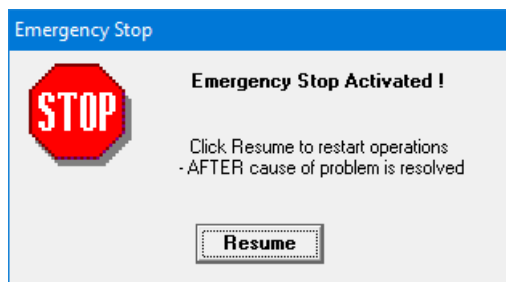

As before, click **Resume** to continue main track operation, but note that all Items on the track will still remain stationary until they receive another speed command from the controller to which they are currently allocated (NCE Cab or Operate 'soft controller').

Be aware, however, that if any of the Locomotives not receiving a specific *Emergency Stop* command are fitted with an onboard "keep-alive" facility (power storage capacitors) then they will continue to move, in the absence of track power, until the charge in their storage capacitors is exhausted. This capacity may be enough to overcome the brief track power interruptions, effectively causing the Emergency Stop to be ignored.

There is also a further complication when using an NCE Power Cab or DCC Twin as your Command Station, if you have a significant number of Accessory decoders powered directly from your mainline track. Following the switch to Program Mode in the Emergency Stop sequence, the extra power taken by the Accessory decoders and attached accessories may well exceed that available from the Command Station output in Program Mode, causing it to immediately remove all power from the track for its own timeout period. Track power will be restored to normal when the Emergency Stop sequence switches the Command Station back to Main Mode.

As well as using the **Emergency Stop** button (STOP) in an Operate window, you can also initiate an Emergency Stop from this or any other A-Track window by pressing the **Pause/Break** key on the **PC keyboard** (usually located, on a standard keyboard, as one of the rightmost keys of the top row of keys, ie. the row which contains the Function keys F1 to F12). Activating an Emergency Stop from the keyboard will attempt to stop *all* Locomotives on the mainline, subject to the limitations described in the preceding paragraphs, and with the appropriate Emergency Stop warning messages displayed as shown previously.

Again, if using an NCE Power Pro Command Station, an advisory message '**AT-E'STP**' is sent to the LCD display of all attached NCE ProCabs, from which it can be removed by pressing that Cab's **ENTER** key. A **second** press of **Pause/Break** is equivalent to clicking the Cut Power button, and will cause power to be removed from the mainline, ensuring that no Items can be restarted by an NCE Cab. Clicking Resume in this state will send a command to the NCE Power Pro Command Station to restore power to the mainline, and control of each Item can then be regained by sending the Item any command from their allocated Controller.

When using an NCE Power Cab, Smart Booster, or DCC Twin Command Station, any second or subsequent press of **Pause/Break** is ignored. Normal operation is restored by clicking the Resume button when it is displayed.

Pressing the **Pause/Break** key when a Command Station is not connected and operational will, of course, have no effect on A-Track or on any locomotives on your model railroad track, other than to display a warning message –

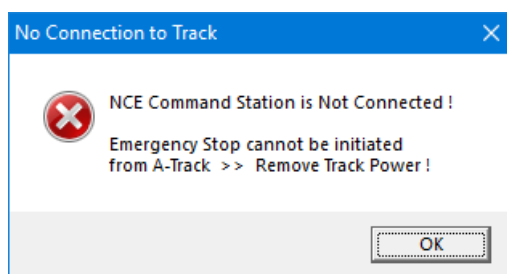

Important Note : An Emergency Stop can also be generated from any of the NCE Cabs which are currently connected to the NCE Cab Bus, as described in the NCE Power Pro and Power Cab System Reference Manuals, but is a completely independent function. A-Track is not aware that such an Emergency Stop has been activated from an NCE Cab, and normal track operation can only be resumed from the activating NCE Cab, following the procedure described in the NCE System Reference Manuals.

6.11 Defining and Assigning Locomotives to Consists

A Consist is a defined group of locomotives which are controlled as a single entity using a single unique address given to the Consist. Technically, as far as the NMRA DCC Standards & Recommended Practices are concerned, this is known as an Advanced Consist, and is the only form of Consist which is handled by A-Track.

An older form of Consist management (Universal or Brute-Force Consists), in which the same commands are sent to each constituent locomotive using their own addresses, is supported directly, for groups of up to four locomotives, by both the NCE Power Pro and Power Cab Systems, but not by A-Track. Further details can be found in the NCE Power Pro and Power Cab System Reference Manuals.

Consists can be defined independently by either type of NCE System, using the commands available through the NCE Handheld Cabs, and by the A-Track program. A-Track allows the definitions of Consists to be transferred to and from an NCE Power Pro or Power Cab Version 1.65 (including Smart Booster and DCC Twin) System so that, by letting you see the exact composition of each Consist, you will be able to resolve any conflicting Consist definitions which might exist between A-Track and the NCE system in use. As described in **Section 3.5**, A-Track loads the addresses of all defined Consists from an NCE Power Pro or Power Cab V1.65 System as soon as it is connected to the Command Station. This facility is not available when operating with an older NCE Power Cab (or Smart Booster) Version 1.28 System, or with an NCE Version 6 USB Interface.

Note, however, that as far as control of a specific Consist is concerned, the definition of its constituent locomotives currently held in any type of NCE Command Station takes precedence over any Consist with the same address currently defined in the A-Track Item List.

From an A-Track point of view, a **Consist** is essentially just another Item, but one which has a very restricted set of parameters, made up of a Description, a Type, an Address, and a list of Locomotives which have been designated as belonging to this Consist. Although a Consist does use some Configuration Variables for its own internal storage, you cannot edit any of these CVs directly.

When a Locomotive Item is **assigned** to a Consist, that Loco's Address is added to the Consist's assignment list, the Type of the assigned Item is changed from Locomotive to **Multiple**, and the Consist Address is stored in CV19 of the Locomotive (now Multiple) Item. You can continue to edit, read/verify, and program the remaining CVs of a Multiple Item in exactly the same way as you can those of an independent Locomotive Item.

Creating a Consist is done simply by inserting a **Blank Item** (see **Sections 3.7, 4.5** and **5.3**) into the Item List then, under the **Identity** Parameter Tab, selecting its Type as **Consist**, typing in a suitable Description and allocating it an Address. Valid values for the Consist Address range from 001 to 127 (the same as Locomotive Primary Addresses), and A-Track will offer you the highest Address value which is not already in use by another Consist.

Note : No check is made that the address allocated to the Consist may already be assigned as the Primary Address of a Locomotive. For this reason, if you intend to define and operate a number of Consists, it is good policy to use Extended Addresses (preferably with values greater than 127) for all of your Locomotives, and reserve addresses in the range 1 to 127 for use exclusively by Consists.

You can choose either to accept the offered Address for your new Consist, or to change it to any other value which is available by typing the address into the **Consist Address** textbox under the **Identity** Parameter Tab. If you select an Address which is in use by another Consist, either in the A-Track Item List or in the NCE Command Station (provided that it has been connected and switched on, so that A-Track has been able to extract a list of currently defined Consists from the Command Station), a warning message will be displayed as shown below –

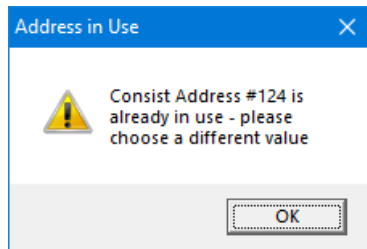

You will also be warned if you enter an invalid value, or if all available addresses have already been allocated.

In particular, if you are using a Power Cab, Smart Booster, or DCC Twin system, the allowable addresses which can be used by Consists held within the Command Station is restricted to a range of 112 to 127. If you give the Consist being defined an address outside this range then, when you click **Update Item** to transfer the Consist to the Item List, A-Track will display a reminder of this restriction –

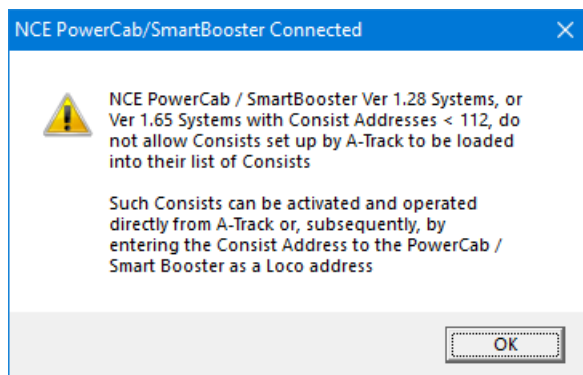

However, assuming that your choice of address is acceptable, the next step in defining the newly-created Consist, is to proceed to **assign** a set of Locomotives to it.

Note that, once any Locomotives are assigned to the new Consist, you will be unable to change the Address allocated to the Consist.

Start Locomotive assignment by clicking on the **Config** Parameter Tab, as shown below –

Item #28 - Addr 000 - Configuration Variables

Item Description Switcher Consist #2

Program CVs
Read/Verify CVs
Copy All CVs
Paste Main CVs
Paste Exten'd CVs
Paste Index'd CVs
Update Item
Close

Identity Config

Item Type
 Accessory
 Consist

Primary Address
Extended Address
Consist Address 120
User Identifier #1

Locomotive Assignment
 Lead Mid 1 Mid 2
 Mid 3 Mid 4 Rear

Assign Address 0000 Fwd Rev
 Auto Assign

Description
No Locomotive Assigned

Assigned Loco List (Lead / Mid 1-4 / Rear)
0000 F No Locomotive Assigned

CV	0x	1x	2x	3x	4x	5x	6x	7x	8x	9x	10x	11x	12x
0	000	000	000	000	000	000	000	000	000	000	000	000	000
1	000	000	000	000	000	000	000	000	000	000	000	000	000
2	000	000	000	000	000	000	000	000	000	000	000	000	000
3	000	000	000	000	000	000	000	000	000	000	000	000	000
4	000	000	000	000	000	000	000	000	000	000	000	000	000
5	000	000	000	000	000	000	000	000	000	000	000	000	000
6	000	000	000	000	000	000	000	000	000	000	000	000	000
7	000	000	000	000	000	000	000	000	000	000	000	000	000
8	000	000	000	000	000	000	000	000	000	000	000	000	000
9	000	120	000	000	000	000	000	000	000	000	000	000	000

A-Track, and the NCE Power Pro Command Station, each allow up to six locomotives to be assigned to, and stored within, a defined Consist, with the locomotive heading the group designated as the Lead Loco, the last locomotive as the Rear Loco, and the other four as Mid Locos. Power Cab, Smart Booster, and DCC Twin Systems will only store a maximum of two Mid Locos in addition to the Lead and Rear Locos.

Note, however that, by using the Handheld Cab controls, all types of NCE System allow you to add as many extra Locos to an Advanced Consist as you wish – the addresses of such extra Locos, however, will not be retained by the Command Station when you switch off, nor can they be stored by A-Track.

Click on one of the **Locomotive Assignment** buttons to select a position – the Lead position is selected in the example above. If the position is available then the **Assign Address** textbox will show '0000', and the **Add Loco** button will be enabled, as shown above. If a locomotive is already assigned to the 'slot' then the Assign Address textbox will show the address of that Locomotive, and the button will show the caption **Remove Loco** instead.

Assuming that the slot is available, click in the **Assign Address** textbox, and type in the address of the Locomotive to be assigned to the Consist. If you type a two- or three-digit value less than 128, then it will be taken as a Primary Address, while a three-digit value greater than 127, or any four-digit value, is assumed to be an

Extended Address. If you wish to enter an Extended Address which is less than 127, then add one or more leading zeros to pad it out to four digits.

Next, click either of the **Fwd** or **Rev** buttons to the right of the textbox to choose whether the Loco is to be operated in the Forward or Reverse direction (Forward is selected by default). If the entered address of the assigned Locomotive can be matched to an active address of a Locomotive in the currently-loaded Item List (the address shown preceded by a '>' symbol), then that Locomotive's Description will be displayed in the Assigned Loco **Description** textbox as shown below -

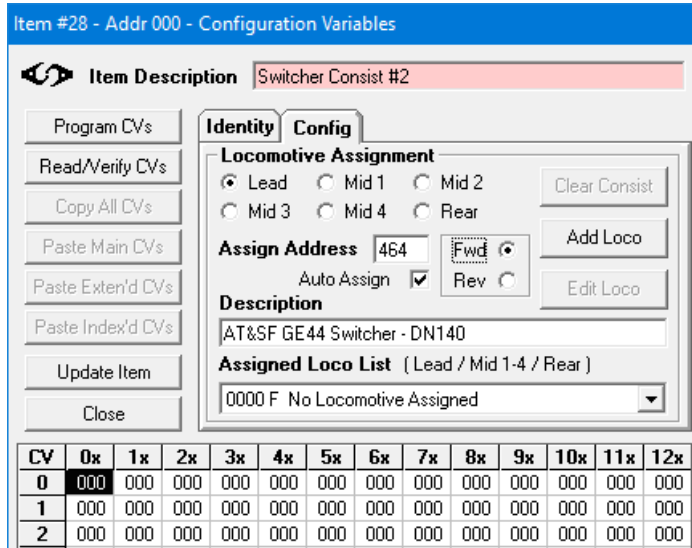

If there is no match to the entered address, then the Description will show "Item not found in Loaded Item List".

Finally, click **Add Loco** to complete the assignment. The Locomotive is added as the first (top) item in the **Assigned Loco List**, and its address is stored in locations corresponding to CV 50 and CV51, as shown below by these values being highlighted in pink -

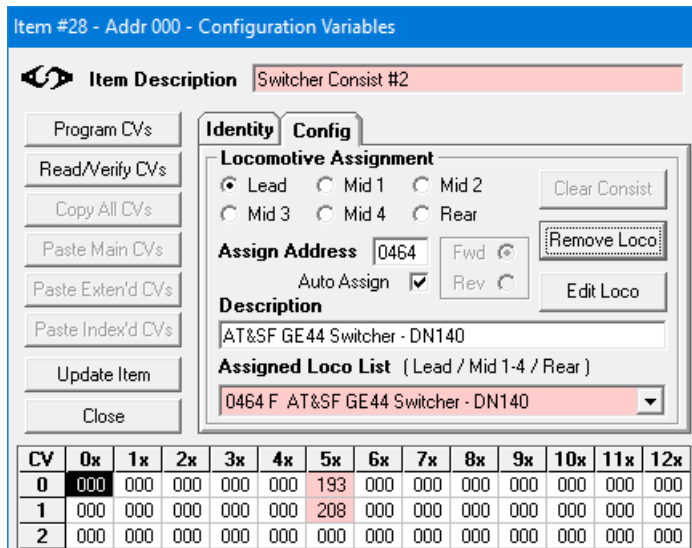

Important Note : If the **Auto Assign** checkbox is ticked (as shown above), A-Track will place the **first** locomotive which you assign to the Consist as the **Lead** Loco, and the **second** locomotive as the **Rear** Loco of the Consist, *regardless* of which vacant Locomotive Assignment Position you actually select before entering the Locomotive address. If Auto Assign is not ticked, then the Locomotive will be assigned to the selected Assignment position.

Unticking the Auto Assign checkbox gives you the same option as the NCE systems, of defining a Consist without a Lead and / or Rear Loco, although such a definition seems somewhat illogical – and is not recommended, since it can confuse the NCE system when you come to edit or delete such a Consist.

Nevertheless, with or without Lead and Rear Locos having been added, assigning further Locomotives to the Consist, in any of the Mid positions, is done by selecting an appropriate position and entering a Locomotive address as often as required. The final state of the example Consist is as shown below –

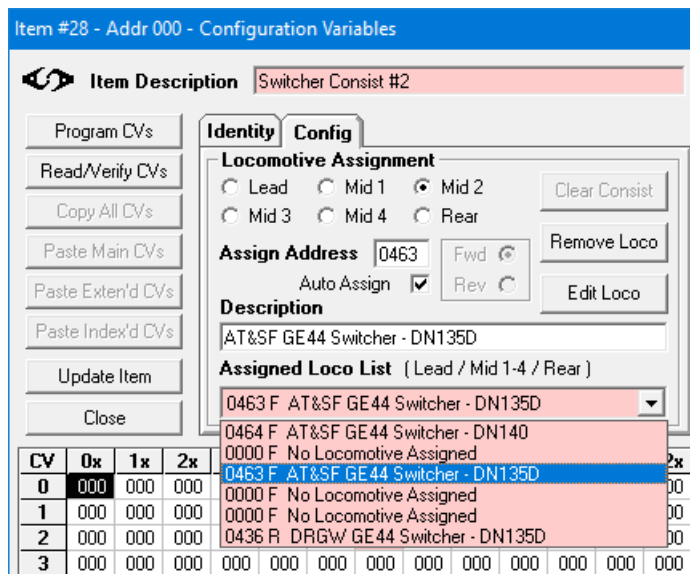

Here the Assigned Loco List has been dropped down by clicking on the down-arrow (▼) at the end of the listbox, and shows that the Rear Loco is set for operation in the Reverse direction, and one Mid Loco has been assigned to the Mid 2 position (currently highlighted).

The format of the Assigned Loco List is fairly obvious, with each row showing the Loco Address followed by its set operating direction (F or R) and the Loco Description from the Item List (where available).

Closing the Assigned Loco List (click on the ▼ down-arrow again) allows us to see where the addresses of all of the assigned Locos are held, namely in locations corresponding to CV50 through CV61, with the operating directions of each of the Locos stored in the lower six bits of CV62 –

Update Item		Assigned Loco List (Lead / Mid 1-4 / Rear)											
Close		0464 F AT&SF GE44 Switcher - DN140											
CV	0x	1x	2x	3x	4x	5x	6x	7x	8x	9x	10x	11x	12x
0	000	000	000	000	000	193	193	000	000	000	000	000	000
1	000	000	000	000	000	208	180	000	000	000	000	000	000
2	000	000	000	000	000	000	032	000	000	000	000	000	000
3	000	000	000	000	000	000	000	000	000	000	000	000	000
4	000	000	000	000	000	193	000	000	000	000	000	000	000
5	000	000	000	000	000	207	000	000	000	000	000	000	000
6	000	000	000	000	000	000	000	000	000	000	000	000	000
7	000	000	000	000	000	000	000	000	000	000	000	000	000
8	000	000	000	000	000	000	000	000	000	000	000	000	000
9	000	120	000	000	000	000	000	000	000	000	000	000	000

However, note that, for a Consist, its Configuration Variables are regarded as a private storage area, so that you cannot edit any of the CV values directly, as you would be able to for any other type of Item – the updated CV values are displayed solely as confirmation that the assignments have been made successfully. All changes to the Consist’s parameters must be made using the buttons and textboxes provided under the Identity and Config Parameter Tabs.

Once you have completed assignments to the Consist, click **Update Item** to transfer the changes to the Item List. If A-Track is connected to an NCE Power Pro or Power Cab Version 1.65 (including Smart Booster and DCC Twin) Command Station, a request to ‘Activate’ the Consist will appear, as shown below –

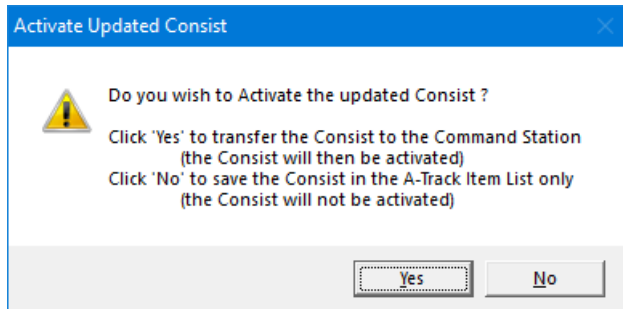

If a Consist with the same address has been created independently within the NCE Command Station (by use of an NCE Handheld Cab) then you will see an extended version of the ‘Activate’ message –

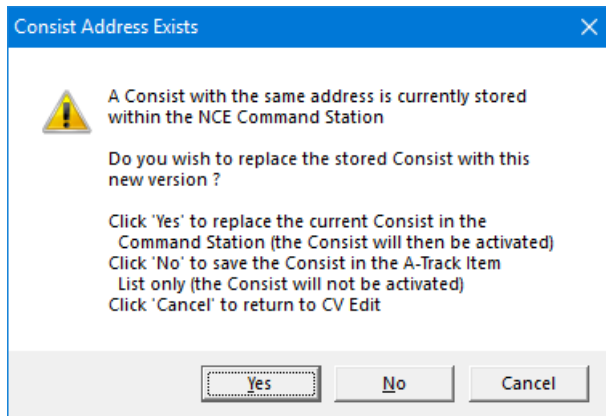

Alternatively, if A-Track is connected to an older NCE Power Cab (or Smart Booster) Version 1.28 System, or with an NCE Version 6 USB Interface, an advisory notice will be shown (click **OK** to continue), followed by a slightly different 'Activate Updated Consist' message, to reflect the situation that Consist data cannot be exchanged between A-Track and such equipment –

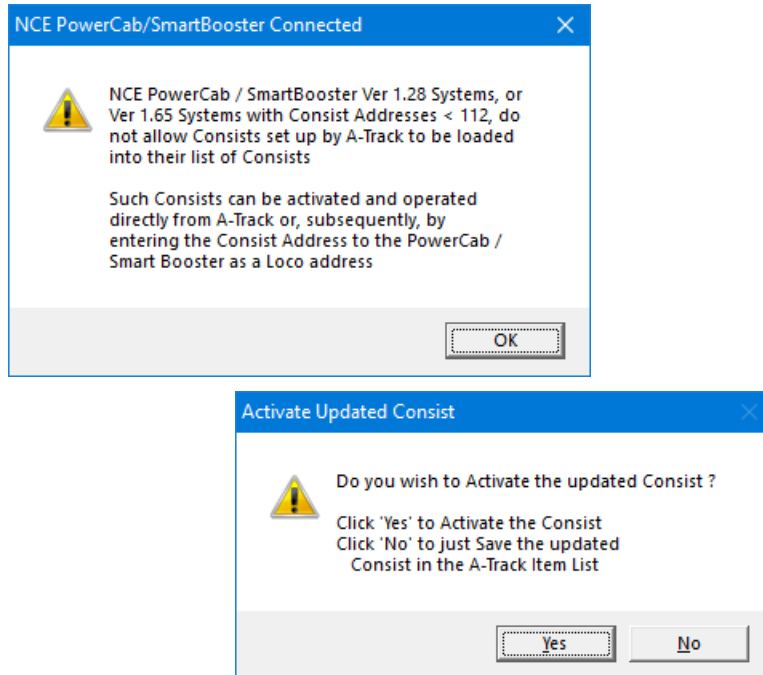

In all of these cases, where A-Track is connected to an NCE Power Pro Command Station, clicking **Yes** to 'Activate' the Consist will transfer the Consist assignments to the Command Station, which then programs the decoders in the assigned Locomotives with the Consist Address.

Alternatively, when using an NCE Power Cab or Smart Booster System, A-Track will issue direct 'Program on the Main' commands to program the Consist Address into the assigned Locomotive decoders, and then, only with a Version 1.65 System and a Consist Address of 112 or greater, store details of the Consist into the Command Station memory. **Be aware** that only the first **two** of any assigned locomotives found in the four Mid Loco positions in the Consist will be transferred to the memory of the Version 1.65 NCE Power Cab or Smart Booster System, or the DCC Twin System.

Until activation occurs, the Consist exists solely in the A-Track Item List. Further details of activation are explained in the following **Section 6.12**.

For the present exercise, just click **No** in response to either **Activate Updated Consist** message, then save the updated Item List to safeguard the new Consist Item.





The Consist and assigned Locomotives now appear in the Item List as follows –

<input type="checkbox"/>	AT&SF GE44 Switcher - DN140	MultiLead	_EP_	=120	>0464	28	F 000	_	_____
<input type="checkbox"/>	AT&SF GE44 Switcher - DN135D	MultiMid	_EP_	=120	>0463	28	F 000	_	_____
<input type="checkbox"/>	DRGW GE44 Switcher - DN135D	MultiRear	_EP_	=120	>0436	28	F 000	_	_____
<input type="checkbox"/>	Switcher Consist #2	Consist	_EP_	>120			F 000	_	_____

The Consist details are displayed with its sole Address in the Primary Address column, where it is shown as the active address (>120). The Item Flags 'E' and 'P' are set as a reminder that the updated Consist and its assigned Multiples have not yet been saved as part of the Item List, and that the Consist has not been activated.

Each of the assigned Locomotive Items has now had its Type changed to Multiple, with the Lead, Rear, and Mid Locos identified both in the Type column and by the appropriate icon at the beginning of each row (see the table of icons at the end of **Section 4.1**). The active address of each assigned Loco is displayed in the appropriate column (either Primary or Extended), with the address of the Consist shown in the *other* Address column, preceded by an '=' symbol.

Note that if a Locomotive is added to the Consist, but the entered Loco address cannot be identified with an Item in the loaded Item List, then, when the Consist is updated, a new, blank Locomotive Item will be added to the Item List, as shown below (New Locomotive #32) –

<input type="checkbox"/>	 AT&SF GE44 Switcher - DN140	Mult'Lead	_EP_	=120	>0464	28	F 000	-	_____
<input type="checkbox"/>	 AT&SF GE44 Switcher - DN135D	Mult'Mid	_EP_	=120	>0463	28	F 000	-	_____
<input type="checkbox"/>	 DRGW GE44 Switcher - DN135D	Mult'Rear	_EP_	=120	>0436	28	F 000	-	_____
<input type="checkbox"/>	 New Locomotive #32	Mult'Mid	_EP_	=120	>0478	28	F 000	-	_____
<input checked="" type="checkbox"/>	 Switcher Consist #2	Consist	_EP_	>120			F 000	-	_____

If the new Locomotive exists in another of your Item Lists then you could copy it into this Item List (see **Section 4.5**) and then copy its parameters and CVs into the new Multiple (New Locomotive #32) – you cannot just change the Item Type from a Locomotive to a Multiple directly – but, in performing the copy, you need to be very careful to keep all Address CVs (CV01, CV17, CV18, and the Consist Address CV19), plus the Configuration Data CV29, exactly the same as they are in the Multiple, or you risk breaking the Consist.

Alternatively, you could try reading all CVs from the real Locomotive decoder into the new Multiple, but you will still need to take care to preserve all of the current Multiple's Address and Configuration values.

Hence, the safest, and recommended, way to deal with this situation is to **remove** New Locomotive #32 from the Consist, as described later in this Section, then copy the relevant Item from another Item List, or create a new Item in this Item List, to correspond to the real Locomotive that you wish to add to the Consist.

Once the correct Item is present in the Item List, you can then re-open the Consist Item (Switcher Consist #2) Edit CVs window and **add** the Locomotive into the Consist as shown previously. This ensures that all of the Consist and Multiple parameters and their CV values are maintained fully consistent.

After completing the Consist assignments you may wish to check that the parameters of each of the assigned Locomotives are consistent with each other.

Double-clicking on an Item entry, such as that for the Lead Loco, in the Item List will open its Edit CVs window, in which you can see the changes made by assigning it to the Consist, ie. the addition of a value and direction for the Consist Address under the Identity parameter Tab, and the value of the Consist Address loaded to CV19 –

Item #24 - Addr(120) 0464 - Configuration Variables

Item Description AT&SF GE44 Switcher - DN140

Item Type

- Accessory
- Consist
- Locomotive
- Mult - Lead
- None

Primary Address 064
 Extended Address 0464
 Consist Address 120 F
 User Identifier #1 000
 User Identifier #2 000
 Manufac Version No. 106
 Manufacturer ID 129

Not Allocated 00 Edited Not Prog'd

CV	0x	1x	2x	3x	4x	5x	6x	7x	8x	9x	10x	11x	12x
0	000	000	000	000	000	000	000	062	150	185	000	000	000
1	064	000	000	000	000	000	000	075	155	187	000	000	000
2	000	000	000	000	000	000	000	087	160	189	000	000	000
3	000	000	000	000	000	000	000	097	164	191	000	000	000
4	000	000	000	000	000	000	128	107	171	192	000	000	000
5	000	000	000	000	000	000	000	116	171	128	000	000	000
6	000	000	000	000	000	000	128	124	175	000	000	000	000
7	106	193	000	000	000	000	016	132	178	000	000	000	000
8	129	208	000	000	000	000	033	138	180	000	000	000	000
9	000	120	050	000	000	000	048	144	183	000	000	000	000

Address includes Consist to which Item is assigned and Item icon now shows Type as Multiple - Lead

Consist Address set in Item - with Forward Direction

Opening the Edit CVs window for the Rear Loco (or any other Multiple which has been set to operate in the Reverse direction) shows that, in such a case, the value of CV19, containing the Consist Address, is set to the assigned Consist Address plus 128 (248 in this case) -

Item #26 - Addr(120) 0436 - Configuration Variables

Item Description DRGW GE44 Switcher - DN135D

Item Type

- Accessory
- Consist
- Locomotive
- Mult - Rear
- None

Primary Address 036
 Extended Address 0436
 Consist Address 120 R
 User Identifier #1 255
 User Identifier #2 255
 Manufac Version No. 051
 Manufacturer ID 129

Not Allocated 00 Edited Not Prog'd

CV	0x	1x	2x	3x	4x	5x	6x	7x	8x	9x	10x	11x	12x
0	000	000	000	000	016	000	000	035	125	215	255	255	015
1	036	000	000	000	032	000	000	044	134	224	255	255	000
2	000	001	000	000	064	000	000	053	143	233	255	255	000
3	000	000	000	001	016	000	000	062	152	242	255	255	000
4	000	000	000	002	032	064	000	071	161	251	255	000	000
5	000	000	000	004	064	128	002	080	170	260	255	000	000
6	000	000	000	008	128	080	008	089	179	255	255	000	000
7	051	193	000	016	000	006	008	098	188	255	255	000	000
8	129	180	000	004	000	000	017	107	197	255	255	000	000
9	000	248	038	008	000	000	026	116	206	255	255	255	000

Address includes Consist to which Item is assigned and Item icon now shows Type as Multiple - Rear

Consist Address set in Item - with Reverse Direction - 128 added to Address in CV19

You now have the opportunity, for example, to click on the **Speed** Parameter Tab and check that the Speed Tables and other settings are consistent with the other assigned Locomotives, or, perhaps, to click on the **Funct'n** Parameter Tab and set the Headlight to be operative when the Lead Locomotive is operating in a Consist –

Item #24 - Addr(120) 0464 - Configuration Variables

Item Description: AT&SF GE44 Switcher - DN140

Program CVs, Read/Verify CVs, Copy All CVs, Paste Main CVs, Paste Exten'd CVs, Paste Index'd CVs, Update Item, Close

Identity, Config, Speed, **Funct'n**, Pages, SUSI

Enable in Alternate Power Mode

FLF FLR F1 F2 F3 F4 F5 F6 F7 F8 F9 F10 F11 F12

Active under Consist Address

FLF FLR F1 F2 F3 F4 F5 F6 F7 F8 F9 F10 F11 F12

Function Output Mapping

F'n LF LR 1 2 3 4 5 6 7 8 9 10 11 12

OP

CV	0x	1x	2x	3x	4x	5x	6x	7x	8x	9x	10x	11x	12x
0	000	000	000	000	000	000	000	062	150	185	000	000	000
1	064	000	000	000	000	000	000	075	155	000	000	000	000
2	000	000	001	000	000	000	000	087	160	189	000	000	000
3	000	000	000	000	000	000	000	097	164	190	000	000	000
4	000	000	000	000	000	000	128	107	168	192	000	000	000
5	000	000	000	000	000	000	001	116	171	128	000	000	000
6	000	000	000	000	000	000	128	124	175	000	000	000	000
7	106	193	000	000	000	000	016	132	178	000	000	000	000
8	129	208	000	000	000	000	033	138	180	000	000	000	000
9	000	120	050	000	000	000	048	144	183	000	000	000	000

Function FLF (Headlight - Forward Direction) set to be active in Consist

After making any other necessary adjustments, click **Update Item** to save the amended Item.

While the Edit CVs window and Config Parameter Tab for the **Consist** was still open, it would also have been possible to access the details of any of the assigned Locomotives directly, instead of going back to select them from the Item List. Select an assigned Locomotive by clicking on either the relevant Locomotive Assignment button or on the Locomotive's entry in the dropped-down Assigned Loco List, then click on the **Edit Loco** button.

This will open a new Edit CVs window displaying the parameters of the selected Locomotive. If you open Edit CVs windows for all of the assigned locomotives then you can check directly that all of their individual parameters are consistent with each other.

Finally, when you are satisfied with the definition of the Consist and its assigned Locos, and after closing all Edit CVs windows, you can now save the complete (changed) Item List to secure storage.

Removal of an assigned Loco from a Consist follows exactly the same sequence of steps as assigning a Locomotive to the Consist in the first place. Open the Consist's Edit CVs window, select the Config Parameter Tab, click on the button in the **Locomotive Assignment** section corresponding to the Locomotive you wish to remove, or click the Locomotive's entry in the dropped-down Assigned Loco List, then click **Remove Loco**.

For Locomotives assigned in a Mid Loco position this action simply removes the selected Loco's Address from the Consist's list and, when you click on **Update Item**, not only will the Consist be saved with its new configuration, but the de-assigned Locomotive will be returned to the Item List with its Type changed back to Locomotive (instead of Multiple), and without the address of the Consist in CV19.

However, if you have the **Auto Assign** checkbox ticked, and then remove the assigned Lead Loco, A-Track will automatically promote whichever Loco is in the next Consist position to be the new Lead Loco. If Auto Assign is not selected then the Lead Loco will simply be removed from the Consist, leaving the Assignment position blank, and will be returned as a Locomotive to the Item List.

Hence, in our example Consist, removing the Lead Loco with **Auto Assign** selected results in the single assigned Mid Loco being moved up to the Lead Loco position –

CV	0x	1x	2x	3x	4x	5x	6x	7x	8x	9x	10x	11x	12x
0	000	000	000	000	000	193	193	000	000	000	000	000	000
1	000	000	000	000	000	207	180	000	000	000	000	000	000
2	000	000	000	000	000	000	032	000	000	000	000	000	000
3	000	000	000	000	000	000	000	000	000	000	000	000	000
4	000	000	000	000	000	000	001	000	000	000	000	000	000
5	000	000	000	000	000	000	000	000	000	000	000	000	000
6	000	000	000	000	000	000	000	000	000	000	000	000	000
7	000	000	000	000	000	000	000	000	000	000	000	000	000
8	000	000	000	000	000	000	000	000	000	000	000	000	000
9	000	120	000	000	000	000	000	000	000	000	000	000	000

In the Edit CVs window shown above, you can see that the Address of the promoted Loco has been removed from CV54 and CV55, and placed in the Lead Loco position at CV50 and CV51. The move can also be seen in the Assigned Loco List –

Item #27 - Addr 120 - Configuration Variables

Item Description Switcher Consist #2

Program CVs
Read/Verify CVs
Copy All CVs
Paste Main CVs
Paste Exten'd CVs
Paste Index'd CVs
Update Item
Close

Identity **Config**

Locomotive Assignment
 Lead Mid 1 Mid 2 Mid 3 Mid 4 Rear
 Clear Consist
 Remove Loco
 Edit Loco

Assign Address 0463
 Auto Assign Fwd Rev

Description
 AT&SF GE44 Switcher - DN135D

Assigned Loco List (Lead / Mid 1-4 / Rear)
 0463 F AT&SF GE44 Switcher - DN135D
 0463 F AT&SF GE44 Switcher - DN135D
 0000 F No Locomotive Assigned
 0000 F No Locomotive Assigned
 0000 F No Locomotive Assigned
 0000 F No Locomotive Assigned
 0436 R DRGW GE44 Switcher - DN135D

CV	0x	1x	2x	3x	4x	5x	6x	7x	8x	9x	10x	11x	12x
0	000	000	000	000	000	000	000	000	000	000	000	000	000
1	000	000	000	000	000	000	000	000	000	000	000	000	000
2	000	000	000	000	000	000	000	000	000	000	000	000	000
3	000	000	000	000	000	000	000	000	000	000	000	000	000
4	000	000	000	000	000	000	001	000	000	000	000	000	000
5	000	000	000	000	000	000	000	000	000	000	000	000	000
6	000	000	000	000	000	000	000	000	000	000	000	000	000
7	000	000	000	000	000	000	000	000	000	000	000	000	000
8	000	000	000	000	000	000	000	000	000	000	000	000	000
9	000	120	000	000	000	000	000	000	000	000	000	000	000

Continuing the example, if we now click **Remove Loco** again, the single remaining assigned Loco will be moved from the Rear Loco position to be Lead Loco –

Item #27 - Addr 120 - Configuration Variables

Item Description Switcher Consist #2

Program CVs
Read/Verify CVs
Copy All CVs
Paste Main CVs
Paste Exten'd CVs
Paste Index'd CVs
Update Item
Close

Identity **Config**

Locomotive Assignment
 Lead Mid 1 Mid 2 Mid 3 Mid 4 Rear
 Clear Consist
 Remove Loco
 Edit Loco

Assign Address 0436
 Auto Assign Fwd Rev

Description
 DRGW GE44 Switcher - DN135D

Assigned Loco List (Lead / Mid 1-4 / Rear)
 0436 R DRGW GE44 Switcher - DN135D

CV	0x	1x	2x	3x	4x	5x	6x	7x	8x	9x	10x	11x	12x
0	000	000	000	000	000	193	000	000	000	000	000	000	000
1	000	000	000	000	000	180	000	000	000	000	000	000	000
2	000	000	000	000	000	000	001	000	000	000	000	000	000
3	000	000	000	000	000	000	000	000	000	000	000	000	000
4	000	000	000	000	000	000	001	000	000	000	000	000	000
5	000	000	000	000	000	000	000	000	000	000	000	000	000
6	000	000	000	000	000	000	000	000	000	000	000	000	000
7	000	000	000	000	000	000	000	000	000	000	000	000	000
8	000	000	000	000	000	000	000	000	000	000	000	000	000
9	000	120	000	000	000	000	000	000	000	000	000	000	000





As well as the Address of the Loco moving from CV60 and CV61 to CV50 and CV51, note that CV62 which holds the operating directions of the assigned Locos has also been updated.

The **Auto Assign** function also operates if you choose to remove the assigned Rear Loco. In this case, the nearest Mid Loco will be moved into the Rear Loco position while the previous Rear Loco is returned to the Item List as an independent Locomotive.

Rather than remove each Locomotive individually from the Consist, you can use the **Clear Consist** button shown above to remove all assigned Locomotives from the Consist in a single step.

Click **Update Item** to save your changes to the Item List (or **Close** to allow all changes to be discarded). Note that after a Clear Consist operation the **blank** Consist, if updated, will remain in the Item List where it is available for new assignments.

If the Item List was updated with the revised Consist after removing the original Lead and Mid Locos, the original Rear Loco (0436) will now be shown in the Item List as the Lead Loco of the Consist, with the removed Locos (0464 and 0463) returned as independent Locomotive Items –

<input type="checkbox"/>	 DRGW GE44 Switcher - DN135D	MultiLead	_EP_	=120	>0436	28	F 000	-	_____
<input type="checkbox"/>	 AT&SF GE44 Switcher - DN140	Loco	_EP_	064	>0464	28	F 000	-	_____
<input type="checkbox"/>	 AT&SF GE44 Switcher - DN135D	Loco	_EP_	063	>0463	28	F 000	-	_____
<input checked="" type="checkbox"/>	 Switcher Consist #2	Consist	_EP_	>120			F 000	-	_____

If an NCE Command Station is connected when you click **Update Item**, then a request to 'Activate' the Consist will appear, as shown previously.

If the Consist has been previously activated, so that the Consist Address has been programmed into each of the assigned Locomotives, then you should activate the Consist again in order to re-program the decoders of all Locomotives which have been removed from the Consist, deleting the Consist Address from their CV19 locations. Details of activation are explained in the following **Section 6.12**.

Whether or not you choose to activate the Consist, when the changed Consist is saved back to the Item List then all de-assigned Locos will be returned to the Item List with their Type changed back to Locomotive, as shown above, and no longer containing the address of the Consist.

A similar de-assignment of Locos will occur if you **Delete** a Consist from the Item List – the Consist will be removed, but all of its assigned Locos will stay in the Item List as normal Locomotives.

However, note very carefully, that if you Delete a Consist, and the Consist has previously been activated, then the **real** Locomotive decoders will still be programmed with the Consist Address in CV19.

If the deleted Consist has been transferred to the Command Station as part of activation you can use an attached NCE Handheld Cab to CLEAR the Consist, ensuring that all affected Locomotives are present on the mainline track (refer to the NCE Power Cab or Power Pro System Reference Manuals for full instructions).

Otherwise you will have to remove the Consist Address manually from each Locomotive, by programming the value of CV19 to zero (000), in order to be able to operate that Locomotive using its own Primary or Extended Address.

Remember also, as explained in **Section 4.5**, that you cannot **Cut, Copy, or Paste** Consists or Multiples using the Copy Buffer if you wish to keep their assignments intact.

If you do wish to **transfer a complete Consist** with its assigned Multiples to another Item List, then you should **check** each of the group of Items (Consist plus Multiples) by clicking in the checkbox at the beginning of each Item row, leaving a tick in each checkbox. Then, from the **File** menu, select **Save Checked** to save the Consist and its group of Multiples as a small, standalone Item List with an appropriate filename.

Next, close the current Item List (saving it if necessary), and **Open** the Item List into which you wish to place the saved Consist. Once the Item List has loaded, click **Open Merge** from the **File** menu, then locate and select the small Item List containing the Consist. A final click on **Open** in the Merge Item List window will add the Consist to the second Item List as desired.

6.12 Transferring and Activating Consists

As mentioned in the preceding **Section 6.11**, Consists can be defined completely independently both by the NCE System, using the commands available through the NCE Handheld Cabs, and by the A-Track program.

While A-Track will prevent you creating a new Consist using the same address as an existing Consist in either A-Track or an attached NCE Power Pro or Power Cab / Smart Booster Version 1.65 or DCC Twin System, the NCE Command Station is not subject to the same constraint, and both systems can independently modify the assignments of any existing Consist without the other being directly aware of the changes.

A-Track, therefore, provides a facility for you to view the composition of all Consists currently defined in either the NCE Command Station or in A-Track itself, and to decide, where there are different versions of the same Consist, which version to accept as the one to use. A-Track then allows the accepted Consist definition to be transferred to or from the NCE Command Station so that both systems hold the same data.

The composition of Consists defined in an older Version 1.28 NCE Power Cab or Smart Booster System are not available for access from A-Track, so that any conflicts cannot be resolved directly. You can, however, activate a Consist defined in A-Track so that it can be controlled on the track using such an NCE Power Cab or Smart Booster System.

Remember, however (as noted previously in **Section 6.11**), that as far as control of a specific Consist on the track is concerned, the definition of its constituent locomotives which is currently held in the NCE Command Station *takes precedence* over any Consist with the same address currently defined in the A-Track Item List.

To see the definitions of all current Consists, click on the **View** menu then select the **Consist Status – Item List / Cmnd Stn** option as shown below –

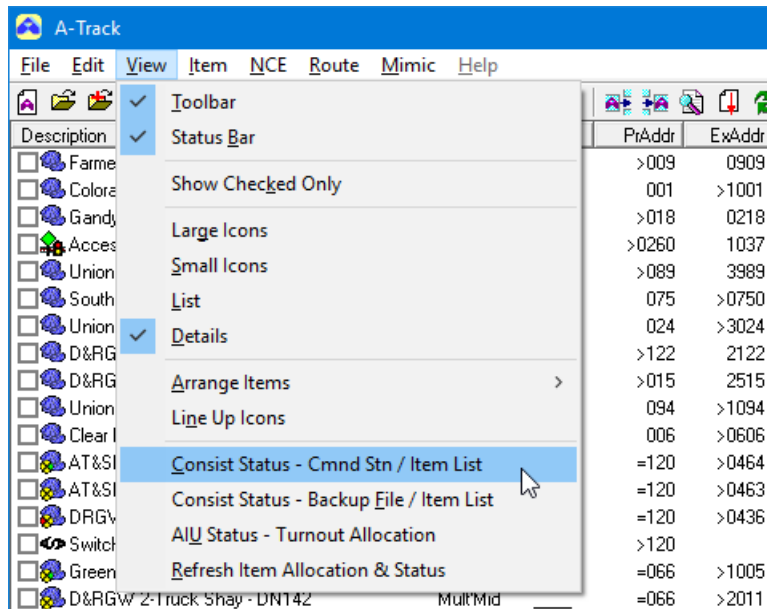

If you are connected to an **NCE Power Pro** or **Power Cab/Smart Booster Version 1.65** or **DCC Twin System**, this will open the windows shown below –

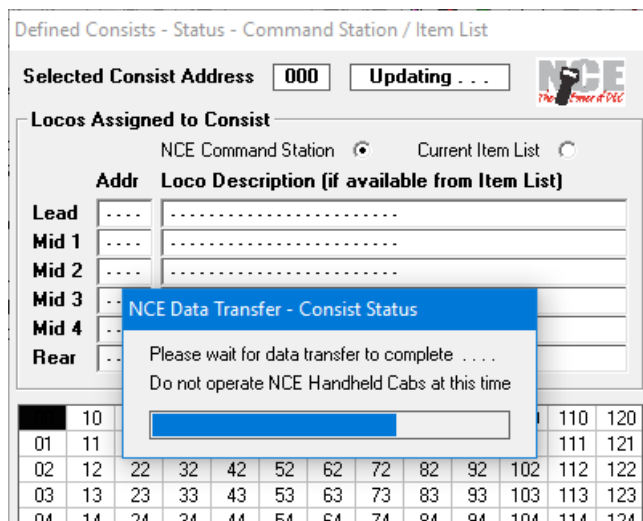

This transfers the latest Consist definitions from the Command Station to A-Track although, as you will have almost certainly observed, existing Consist status is always collected from the NCE Power Pro or Power Cab V1.65 Command Station as soon as A-Track is started and connected. The transfer is repeated now to ensure that you are working with the most up-to-date Consist data and, once the transfer is complete, the Consist Status window is updated to show all Consists which are currently defined. No data transfer takes place when you are connected to an older Version 1.28 System.

Consist Addresses which are in use currently are highlighted in the grid in the lower half of the window with one of three background colours. Consists which are defined solely within the A-Track Item List are shown in **blue** (eg. 120), those defined only in the NCE Command Station in **green** (eg. 085), and those Consists which exist in both the Item List and the Command Station are shown in **orange** (eg. 066) –

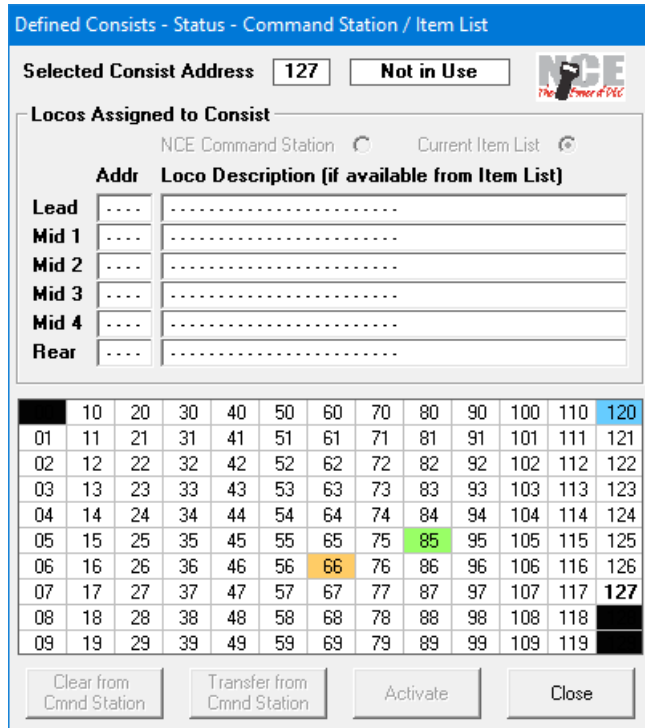

Clicking on any non-highlighted Consist Address in the grid (such as the default address of 127 shown above) will simply display the message **'Not in Use'** in the textbox at the top of the window.

If you are connected to any version of an **NCE Power Cab, Smart Booster, or DCC Twin System**, before the status of all Consist Addresses is displayed you will see a message alerting you to the limitations of such Systems –

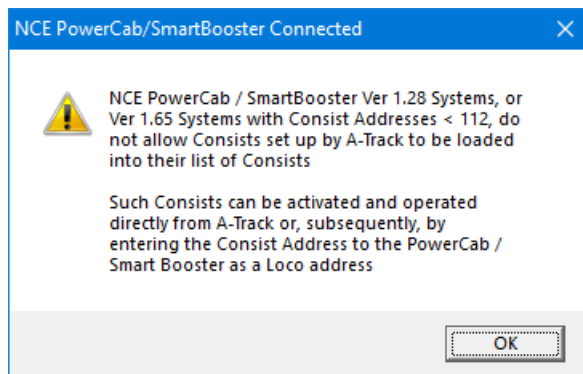

– clicking **OK** will then reveal the Consist Status window which, for a Version 1.28 System shows, in the grid in the lower half of the window and, highlighted in **blue**, only those Consists which are currently defined in the Item List (ie. 120 and 066 in this example) –

	10	20	30	40	50	60	70	80	90	100	110	120
01	11	21	31	41	51	61	71	81	91	101	111	121
02	12	22	32	42	52	62	72	82	92	102	112	122
03	13	23	33	43	53	63	73	83	93	103	113	123
04	14	24	34	44	54	64	74	84	94	104	114	124
05	15	25	35	45	55	65	75	85	95	105	115	125
06	16	26	36	46	56	66	76	86	96	106	116	126
07	17	27	37	47	57	67	77	87	97	107	117	127
08	18	28	38	48	58	68	78	88	98	108	118	
09	19	29	39	49	59	69	79	89	99	109	119	

Clear from Cmd Station Transfer from Cmd Station Activate Close

- while, for a Version 1.65 System, the grid will also show any Consists in the address range of 112 to 127 which have been loaded from the Command Station, such as 124 shown in the example below -

	10	20	30	40	50	60	70	80	90	100	110	120
01	11	21	31	41	51	61	71	81	91	101	111	121
02	12	22	32	42	52	62	72	82	92	102	112	122
03	13	23	33	43	53	63	73	83	93	103	113	123
04	14	24	34	44	54	64	74	84	94	104	114	124
05	15	25	35	45	55	65	75	85	95	105	115	125
06	16	26	36	46	56	66	76	86	96	106	116	126
07	17	27	37	47	57	67	77	87	97	107	117	127
08	18	28	38	48	58	68	78	88	98	108	118	
09	19	29	39	49	59	69	79	89	99	109	119	

Clear from Cmd Station Transfer from Cmd Station Activate Close

Clicking on any highlighted Consist Address in the grid will display the addresses of those locomotives assigned to the Consist in the upper half of the window, with the **Current Item List** option selected in this case to show that this is the A-Track Item List definition of the Consist.

If the displayed addresses correspond to Locomotives in the Item List, then those Locomotive Descriptions will be shown in the textbox to the right of each address, as can be seen below -

Defined Consists - Status - Command Station / Item List

Selected Consist Address 120 A-Track

Locos Assigned to Consist

NCE Command Station Current Item List

	Addr	Loco Description (if available from Item List)
Lead	0464	AT&SF GE44 Switcher - DN140
Mid 1	0000
Mid 2	0463	AT&SF GE44 Switcher - DN135D
Mid 3	0000
Mid 4	0000
Rear	0436	DRGW GE44 Switcher - DN135D

	10	20	30	40	50	60	70	80	90	100	110	120
01	11	21	31	41	51	61	71	81	91	101	111	121

Continuing with the situation where you are connected to an NCE Power Cab or Smart Booster Version 1.28 System, the Consist Status window now offers you the opportunity to **activate** the Consist, ie. to program the address of the Consist into the assigned Locomotives on the track.

Select the required Consist by clicking on its highlighted Address in the grid (120, in this example) then click the **Activate** button to start the process, which will begin by displaying a reminder to ensure that the Locomotives to be programmed are *physically present* on the Mainline Track (*not* the Program Track) –

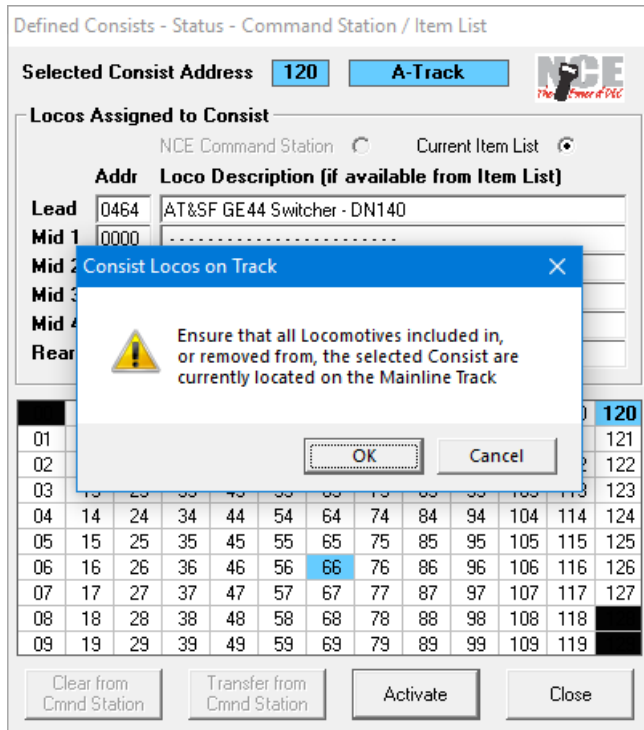

Click **OK** to proceed with the issue of the appropriate programming commands to the NCE System, or **Cancel** to abandon the Activation process (if, for example, the required Locomotives are not all in position).

Once activated, the Consist Address entry is highlighted in **dark blue** –

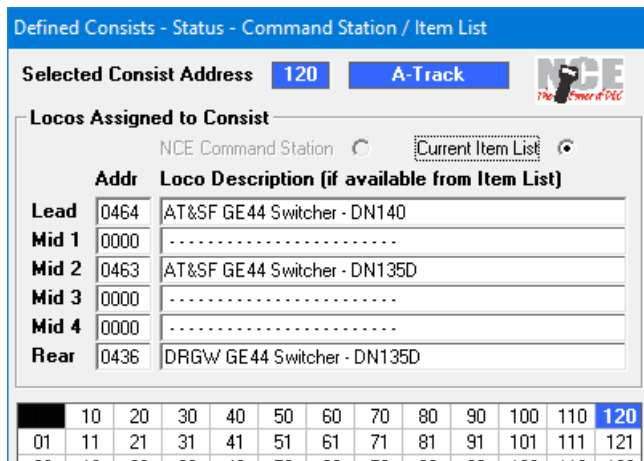

Important Note : Due to the limitations of the NCE USB Interface and NCE Power Cab or Smart Booster Systems, the assigned Locomotives have to be programmed with the Consist Address using Operations Mode (Programming on the Mainline) commands. If the Locomotives do not fully support Operations Mode, particularly with regard to allowing programming of their Consist Address, then their assignment, and activation of the Consist, will fail (although A-Track will assume that the operation has succeeded, since there is no feedback of status from the track via the NCE equipment in Operations Mode).

If you watch the assigned Locomotives on the track during programming you may see each Locomotive move briefly, or flash some of its lights, as a visual acknowledgement of receipt of the Consist address (depending on the decoder fitted), as power is applied momentarily to the motor or other decoder functions.

The activated Consist can be controlled from an NCE Power Cab or Pro Cab by pressing the **SELECT LOCO** key, and entering the Consist address followed by the Cab's **ENTER** key. However, note that the NCE System will not recognise the entered address as a Consist, but will simply treat it as another Locomotive.

Assuming that the selected Consist was successfully activated, selecting its highlighted Address in the Consist Status window will now give you the option to deactivate, or 'kill', the Consist by clicking the **Clear Directly on Track** button, as shown below –

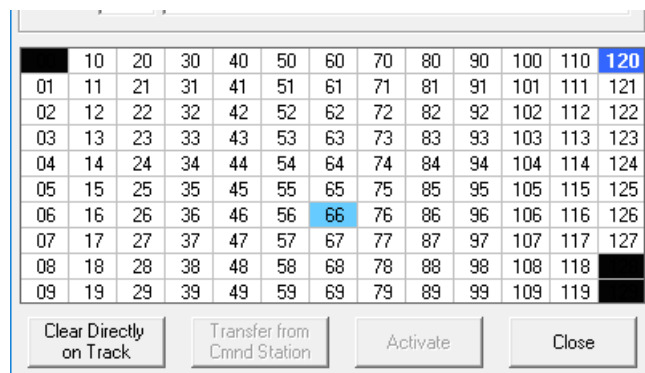

After clicking **Clear Directly on Track**, you will again be prompted to ensure that the Locomotives to be removed from the Consist are physically present on the Mainline Track, with the option to click **OK** to proceed, or **Cancel** to do otherwise. Clicking **OK** will generate the appropriate Operations Mode commands to remove the Consist Address from the assigned Locomotives, and A-Track will then assume that the deactivation has been successful. The Consist will remain unaltered in the Item List ready to be re-activated at any time in the future.

Given the very limited facilities available to A-Track to handle Consists with an NCE Power Cab or Smart Booster Version 1.28 System, you may choose to ignore the Activate and Clear functions, and instead enter all of the Consist details and Loco addresses directly into the NCE System, as an Advanced Consist, using your NCE Cab. This has the advantage that the Consist is recognised, and can be controlled as such, by the NCE System, while a permanent record of the Locomotive assignments can still be maintained independently in the A-Track Item List.

On the other hand, if using an **NCE Power Cab/Smart Booster Version 1.65** or **DCC Twin System**, A-Track does have access to any Consists stored within the Command Station. Such Consists will have addresses in the range 112 to 127.

Hence, if the previous example is repeated with a Version 1.65 System, and Consist 120 is Activated, the operation will still be carried out by using Operations Mode (Programming on the Mainline) commands to program the Consist Address into the assigned Locomotives but, in addition, a copy of the Consist will also be transferred to the Command Station memory, and the Consist Address entry will be highlighted in **orange** –

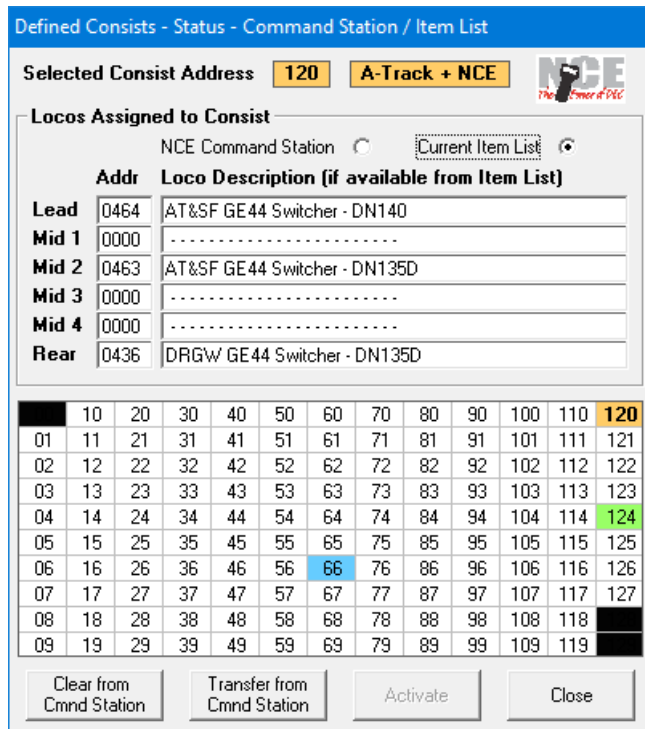

Remember, as mentioned in the previous **Section 6.11**, that only the first **two** of any assigned locomotives found in the four Mid Loco positions in the Consist will be transferred to the memory of the Version 1.65 NCE Power Cab or Smart Booster System, or the DCC Twin System.

The Command Station will now recognise the Consist, and allow it to be controlled from an NCE Handheld Cab by selecting the address of either the Lead or Rear Loco via the **SELECT LOCO** function.

Activating a Consist held in the A-Track Item List with an address outside of the range 112 to 127, such as Consist 066, will be handled as for a Power Cab Version 1.28 System.

Once activated, the Consist Address entry is highlighted in **dark blue** as shown below, and will need to be controlled from an NCE Power Cab or Pro Cab by pressing the **SELECT LOCO** key, and entering the Consist Address followed by the Cab's **ENTER** key. Again, note that the NCE System will not recognise the entered address as a Consist, but will simply treat it as another Locomotive –

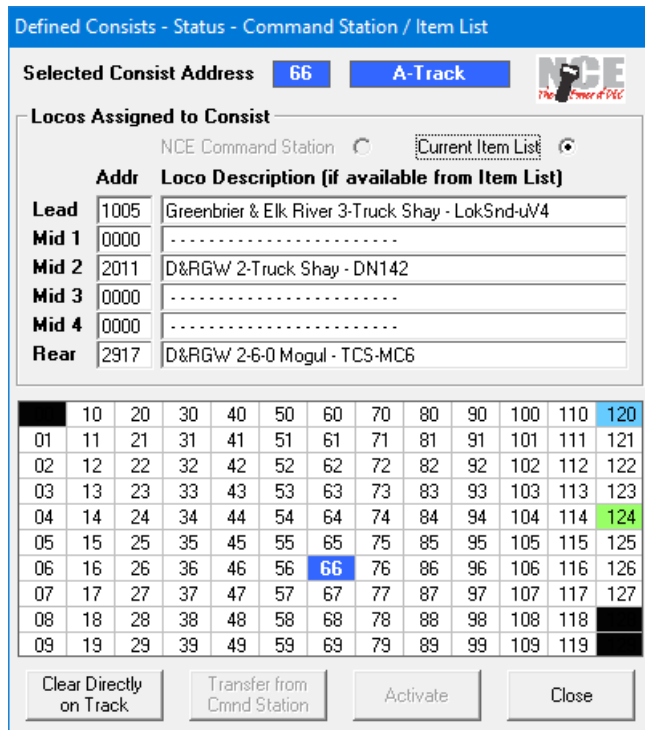

Although the **NCE Power Pro Command Station** retains the current Consist definitions when it is switched off (assuming that its internal backup battery is in good condition), this is **not** true of the **DCC Twin**, or **Power Cab/Smart Booster Version 1.65** when these definitions are transferred from A-Track. The latter Command Stations will only retain Consist definitions made using the NCE Cab control buttons, and these take precedence over any subsequent transfers from A-Track. Transferred A-Track Consist definitions **will not be retained** after switching off the Command Station.

Because of this deficiency in Version 1.65 and DCC Twin systems, A-Track incorporates a facility, as described later in **Section 9.1**, to save the complete status of such a Command Station as a backup file on your computer’s hard disk, and to restore this status, including Consist definitions, automatically when A-Track and the associated Command Station are next switched on.

Without automatic restore enabled, A-Track will simply load whatever Consist definitions have been made previously with the NCE Cab controls – not necessarily those made and transferred earlier using A-Track.

In contrast to the complications involved with handling Consists in Power Cab and Smart Booster Systems, connecting to an **NCE Power Pro Command Station** allows a much more integrated approach to Consist operations between A-Track and the NCE System. As shown earlier in this Section, the Consist Status window allows you to see, at a glance, all defined Consists, including those which exist only in A-Track, or only in the NCE Command Station, or which are held in both locations.

If we repeat one of the previous examples by clicking on Consist Address 120 in the Consist Status window grid (where the Consist is currently defined only in the A-Track Item List) and then clicking **Activate**, details of the Consist will be transferred to the

NCE Power Pro Command Station, where it will be available for control and operation on the track.

The transfer is preceded by the usual reminder to make sure that Locomotives making up the Consist are physically present on the Mainline Track –

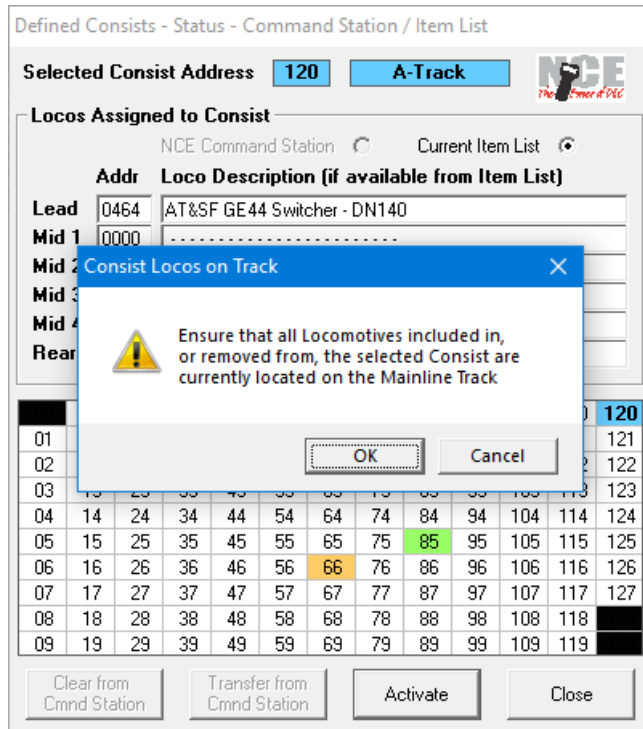

Click **OK** to proceed with the transfer, which will be confirmed by the background to Consist Address 120 changing from **blue** to **orange** –

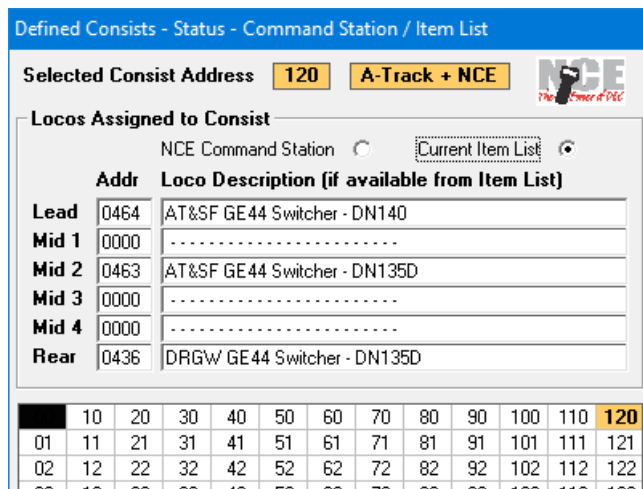

Important Note : In order to **activate** a Consist correctly, it is **essential** that the locomotives which have been assigned to the Consist are physically present on the mainline track *at the time* that the Consist is activated, so that the NCE Command Station can reprogram the locomotive DCC decoders with the appropriate Consist Address (this also applies if a Consist is created or modified directly in the NCE

Command Station from an NCE Handheld Cab). If any of the locomotives are not on the track (or otherwise fail to receive the 'Assign to Consist' DCC command) then their assignment to the Consist will not be made. All NMRA-compliant decoders support the 'Assign to Consist' DCC command which will be issued by the NCE Power Pro Command Station when the Consist is activated from A-Track and, unlike the situation when using NCE Power Cab or Smart Booster Systems, there is no need for the decoder to support Operations Mode programming of the Consist Address.

The same condition applies when locomotives are removed, or de-assigned, from the Consist, and the edited Consist is then activated. Such locomotives *must* be physically present on the mainline track when the edited Consist is activated, so that the NCE Command Station can erase the Consist Address from their decoders.

If we now look at a Consist which is currently defined in both A-Track and the NCE Command Station, such as 066 (highlighted in **orange**), by clicking on its highlighted address in the grid in the lower half of the window, you will be able to see that the assignments held by the Command Station are not the same as those held in the A-Track Item List – as shown by clicking the relevant option button (labelled **NCE Command Station** or **Current Item List**) located above the list of Assigned Loco Descriptions –

The screenshots show the 'Defined Consists - Status - Command Station / Item List' window. The top section shows the 'Selected Consist Address' as 66, with 'A-Track + NCE' selected. Below this, there are two radio buttons: 'NCE Command Station' (selected in the right screenshot) and 'Current Item List' (selected in the left screenshot).

Left Screenshot (Current Item List):

Addr	Loco Description (if available from Item List)
Lead	1005 Greenbrier & Elk River 3-Truck Shay - LokSnd-uV4
Mid 1	0000
Mid 2	2011 D&RGW 2-Truck Shay - DN142
Mid 3	0000
Mid 4	0000
Rear	2917 D&RGW 2-6-0 Mogul - TCS-MC6

Right Screenshot (NCE Command Station):

Addr	Loco Description (if available from Item List)
Lead	1005 Greenbrier & Elk River 3-Truck Shay - LokSnd-uV4
Mid 1	2011 D&RGW 2-Truck Shay - DN142
Mid 2	0000
Mid 3	0000
Mid 4	0000
Rear	0606 Clear Lake Lumber 2-Truck Climax - ZimoMX648R

Both screenshots include a grid of addresses (01-120) with address 66 highlighted in orange. The bottom of each window has buttons for 'Clear from Cmnd Station', 'Transfer from Cmnd Station', 'Activate', and 'Close'.

Although the Lead and Mid Locos are the same, the Rear Loco is different, possibly as a result of a change made to the Consist directly through an NCE Handheld Cab.

If you want to accept the Command Station assignments as the definitive version of the Consist, then click the **Transfer from Cmnd Station** button to copy the assigned Loco addresses from the Command Station to the Item List, and to replace the existing A-Track definition of the Consist.

A message is then displayed to alert you to the fact that the Directions of Operation of Assigned Locos are not available for transfer from the NCE Command Station, so you are requested to select a Direction for each Loco in the Consist –

The Command Station relies on the assigned Direction being programmed into each assigned locomotive decoder when the Consist is activated, but does not store this aspect of the assignment in its own memory. A-Track, therefore, sets all Directions in the Consist definition to Forward (**Fwd**), and requests that you change the Direction of any Assigned Loco wherever necessary. The example below shows the Direction of the Rear Loco being set to Reverse (**Rev**) –

Click **Confirm** to continue and copy the Consist details to the Item List, or **Cancel** to abandon the transfer, leaving both versions of the Consist unchanged.

After the transfer, the new composition of the Consist can be seen in the Item List –

<input type="checkbox"/>	D&RGW 2-6-0 Mogul - TCS-MC6	Loco	_E_	017	>2917	28	F 000	-	_____
<input type="checkbox"/>	Logging Consist #1	Consist	_EP_	>066			F 000	-	_____
<input type="checkbox"/>	Greenbrier & Elk River 3-Truck Shay - LokSn...	MultiLead	_EP_	=066	>1005	28	F 000	-	_____
<input type="checkbox"/>	D&RGW 2-Truck Shay - DN142	MultiMid	_E_	=066	>2011	28	F 000	-	_____
<input type="checkbox"/>	Clear Lake Lumber 2-Truck Climax - ZimoMX...	MultiRear	_E_	=066	>0606	28	F 000	-	_____

Note that the previous Rear Loco (2917 – highlighted above the revised Consist) now appears in the Item List as an independent Locomotive, and has been replaced by a different Loco (0606) with its type changed to Multiple-Rear.

If, for any reason, you have second thoughts about the new definition of the Consist, you can, of course, use the A-Track **Undo** facility to restore the Item List (and its version of the Consist) to its pre-Transfer state.

Note that you can, if you wish, avoid all of these complications by choosing to define and edit all Consists only in A-Track, activating them in the NCE Command Station when required, and not making any changes to Consists through the NCE Handheld Cabs.

Returning to our previously-defined Consists, if instead of transferring the NCE Command Station version of Consist 066 to A-Track, you wish to perform the opposite action, and replace the Command Station Consist with the version defined in the Item List, first click the **Clear from Cmd Station** button to remove the Consist completely from the Command Station (ensuring, as usual, that the assigned Locomotives are in position and ready on the Mainline Track to be reprogrammed).

The background to the Consist Address (066) changes from **orange** to **blue** –

Defined Consists - Status - Command Station / Item List

Selected Consist Address 66 A-Track

Locos Assigned to Consist

NCE Command Station Current Item List

	Addr	Loco Description (if available from Item List)
Lead	1005	Greenbrier & Elk River 3-Truck Shay - LokSnd-uV4
Mid 1	0000
Mid 2	2011	D&RGW 2-Truck Shay - DN142
Mid 3	0000
Mid 4	0000
Rear	2917	D&RGW 2-6-0 Mogul - TCS-MC6

10	20	30	40	50	60	70	80	90	100	110	120	
01	11	21	31	41	51	61	71	81	91	101	111	121
02	12	22	32	42	52	62	72	82	92	102	112	122
03	13	23	33	43	53	63	73	83	93	103	113	123
04	14	24	34	44	54	64	74	84	94	104	114	124
05	15	25	35	45	55	65	75	85	95	105	115	125
06	16	26	36	46	56	66	76	86	96	106	116	126
07	17	27	37	47	57	67	77	87	97	107	117	127
08	18	28	38	48	58	68	78	88	98	108	118	
09	19	29	39	49	59	69	79	89	99	109	119	

Clear from Cmd Station
Transfer from Cmd Station
Activate
Close

Next, click **Activate** to transfer the Consist from the A-Track Item List to the NCE Command Station. The background to the Consist Address will change back to **orange** to confirm the copy operation -

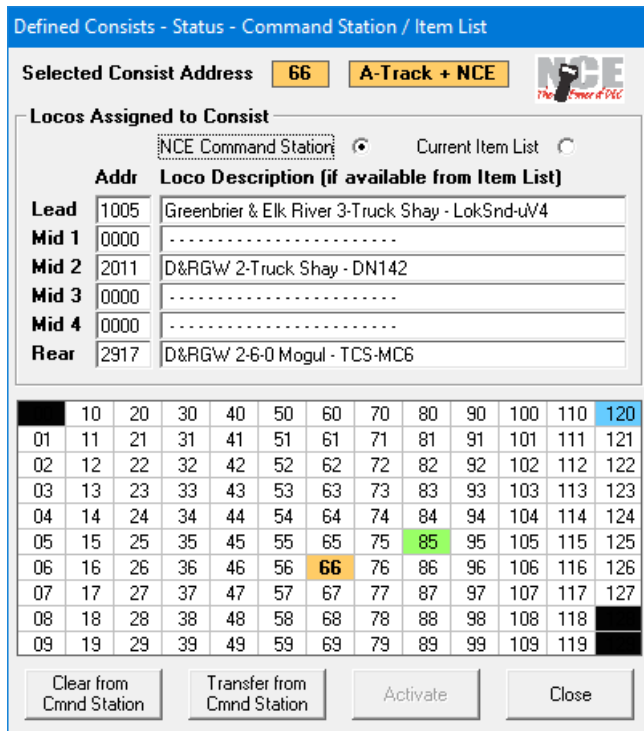

This time, following the activation, the only change visible in the Item List is that the Consist and each of its assigned Locomotives now have their **Activation Flag 'V'** set to show that this Consist has been activated by A-Track (rather than via an NCE Cab), as shown in the Item List below -

<input type="checkbox"/>		Clear Lake Lumber 2-Truck Climax - ZimoMX...	Loco	___	=066	>0606	28	F 000	_	_____
<input type="checkbox"/>		Greenbrier & Elk River 3-Truck Shay - LokSnd...	Mult'Lead	__PV	=066	>1005	28	F 000	_	_____
<input type="checkbox"/>		D&RGW 2-Truck Shay - DN142	Mult'Mid	__V	=066	>2011	28	F 000	_	_____
<input type="checkbox"/>		D&RGW 2-6-0 Mogul - TCS-MC6	Mult'Rear	__V	=066	>2917	28	F 000	_	_____
<input type="checkbox"/>		Logging Consist #1	Consist	__V	>066			F 000	_	_____

There are no changes to either the composition of the Consist itself, or to Locomotive 0606 which has been released as Rear Loco from the Command Station version of the Consist, and which can now operate on the track as an independent locomotive (as it had appeared in the Item List).

The final case to consider in dealing with Consists, is where the Consist is only defined in the NCE Command Station, as in the case of Consist 085, which is shown with a **green** background.

Clicking on this Consist Address shows that, in this example, only the Assigned Lead Loco can be allocated an Item List Description, and that the other assigned addresses cannot be matched with any Locomotives in the current Item List.

The options available are either to **Clear** the Consist (in which case it will be completely erased from the Command Station) or to **Transfer** it to A-Track -

Defined Consists - Status - Command Station / Item List

Selected Consist Address **85** **NCE** 

Locos Assigned to Consist

NCE Command Station Current Item List

	Addr	Loco Description (if available from Item List)
Lead	3024	Union Pacific 2-6-2 Prairie SDN144PS
Mid 1	3028	Item not found in Loaded Item List
Mid 2	0000
Mid 3	0000
Mid 4	0000
Rear	5278	Item not found in Loaded Item List

	10	20	30	40	50	60	70	80	90	100	110	120
01	11	21	31	41	51	61	71	81	91	101	111	121
02	12	22	32	42	52	62	72	82	92	102	112	122
03	13	23	33	43	53	63	73	83	93	103	113	123
04	14	24	34	44	54	64	74	84	94	104	114	124
05	15	25	35	45	55	65	75	85	95	105	115	125
06	16	26	36	46	56	66	76	86	96	106	116	126
07	17	27	37	47	57	67	77	87	97	107	117	127
08	18	28	38	48	58	68	78	88	98	108	118	
09	19	29	39	49	59	69	79	89	99	109	119	

Clear from Cmnd Station Transfer from Cmnd Station Activate Close

Choosing to click the **Transfer from Cmnd Station** button will result firstly, as described previously, in the display of a request to set the Directions of Operation of each of the constituent Locos. In this case we will choose to set the Mid 1 Loco to operate in Reverse (since, perhaps, we can see how the Consist Locos are physically placed relative to each other on the track at this time) –

Defined Consists - Status - Command Station / Item List

Selected Consist Address **85** **NCE** 

Locos Assigned to Consist

NCE Command Station Current Item List

	Addr	Loco Description (if available from Item List)
Lead	3024	Union Pacific 2-6-2 Prairie SDN144PS
Mid 1	3028	Item not found in Loaded Item List
Mid 2	0000
Mid 3	0000
Mid 4	0000
Rear	5278	Item not found in Loaded Item List

Directions of Operation for the Assigned Locos are not stored in the NCE Command Station, so are not available for transfer to A-Track

Select required Direction of Operation for each Assigned Loco to complete transfer of the Consist

Cancel Confirm

Clear from Cmnd Station Transfer from Cmnd Station Activate Close

Lead Fwd Rev

Mid 1 Fwd Rev

Mid 2 Fwd Rev

Mid 3 Fwd Rev

Mid 4 Fwd Rev

Rear Fwd Rev

Clicking **Confirm** will complete the transfer to A-Track. The background of the Address changes to **orange**, together with the creation of two new Locomotives (#22 and #23) in the Item List –

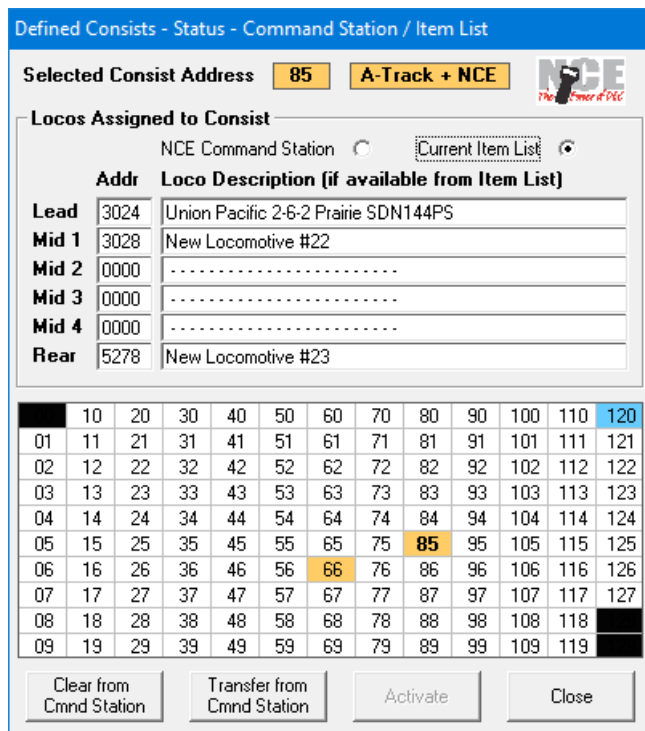

A new Consist Item is also added to the Item List, shown as 'New Consist #20' in the Item List fragment below –

<input type="checkbox"/>		New Consist #20	Consist	_EP_	>085			F 000	-	_____
<input type="checkbox"/>		Union Pacific 2-6-2 Prairie SDN144PS	Mult'Lead	_EP_	=085	>3024	128	F 000	-	_____
<input type="checkbox"/>		New Locomotive #22	Mult'Mid	_EP_	=085	>3028	28	F 000	-	_____
<input type="checkbox"/>		New Locomotive #23	Mult'Rear	_EP_	=085	>5278	28	F 000	-	_____

The Assigned Loco which was identified in the loaded Item List (3024) is now displayed as the Multiple-Lead below the New Consist, and two new Items 'New Locomotive #22' and 'New Locomotive #23' have been created as Multiple-Mid and Multiple-Rear, respectively. Since none of the Items were activated from A-Track, their Activation flags (V) are not set.

As noted previously, in **Section 6.11**, you can now proceed (if you wish) to update the parameters and descriptions of New Consist#20 and both New Locomotives #22 and #23, and then save the revised Item List to permanent storage.

Following the previous recommendations, the **safe** way to deal with this situation is to **remove** both New Locomotives #22 and #23 from the Consist, and then either copy the corresponding Loco Items from another Item List, if you have them already recorded, or to update the parameters and CVs of Locos #22 and #23 in this Item List, to correspond to the real Locomotives that you wish to place in the Consist.

Before attempting to assign the Locos to the Consist, you may wish to check that the parameters of each of the potential assigned Locomotives are consistent with each

other. In particular, note that the Lead Loco here is set to operate with 128-Step Precision, whereas the New Locomotives are set (by default) to operate with 28-Step Precision. This may not be the case if suitable Items are copied into the Item List but, if changes are required, then you may choose to temporarily remove the actual locomotive physically from the Consist, place it on your Program Track, and re-program whichever parameters are necessary.

Once the correct Items are present in the Item List, you can then re-open the Consist Item (New Consist #20) Edit CVs window and **add** the Locomotives into the Consist as shown previously. This ensures that all of the Consist and Multiple parameters and their CV values are maintained fully consistent. You may then give the Consist an appropriate Description before clicking **Update Item** to copy it back into the Item List, selecting an option to **Activate** the Consist on the way.

Although the procedures described in this section should result in the implementation of correctly configured Consists in both A-Track and the NCE Command Station, there may be occasions where one of the constituent Locomotives fails to be programmed with the correct Consist Address when the Consist is activated (such as not being physically present on the track at the time).

It is possible to fix this by directly programming the Consist Address into the affected Locomotive (Multiple), on either the Mainline or the Program Track, using the techniques described in **Sections 5.4** and **6.7**. This should be regarded as a repair operation only, since it will not have any effect on the definition of the Consist in either the NCE Command Station or A-Track.

Open an **Edit CVs** window by double-clicking on the entry for the unprogrammed Multiple in the Item List, *right-click* on **CV19** in the CV Value Grid, and check that the Consist Address is correctly shown in the **Dec** textbox in the Configuration Variable Value window which is displayed. Enter the correct Consist Address if necessary. If the Multiple is to operate in the Reverse Direction, then **add 128** to the entered value of the Consist Address (most easily done by clicking the appropriate checkbox to set **Bit 7**).





Click **OK** to update the value of CV19 if necessary, then click on CV19 in the grid to highlight it (**yellow** background). Click on **Program CVs** to open the Program Config'n Variables window where you should choose the CV Range option as **Current View** and the CV Scope option as **Selected**. If you wish to program the locomotive on the Mainline Track rather than the Program Track (and you know the locomotive will accept such programming), then click to tick the **Program on Main Track** checkbox, and finally click **Confirm** to program the required Consist Address into the locomotive decoder.

If the locomotive is on the Program Track then you can use **Read/Verify CVs** to check that the decoder has now been programmed correctly (see **Section 6.6**). Otherwise, test that the Multiple now works correctly as a member of the Consist.

However, in many cases, the simplest approach to correcting any failure to program a constituent Locomotive in a Consist is, after ensuring that all Locos are present on the track (and in good contact with it), to use A-Track to **Clear** the Consist, and then **Activate** it once again.





6.13 Controlling Consists

When selecting a defined Consist for operation on the track from an NCE Cab, the NCE Command Station (Power Cab, Smart Booster, or Power Pro) will normally expect you to enter either the address of the assigned Lead Loco for normal (forward) control, or the address of the assigned Rear Loco for operation of the Consist in reverse. These two Loco addresses are used by the Command Station to identify the Consist. An example of this is shown below, where the Lead Loco has been selected from NCE Cab 04 –

<input type="checkbox"/>	 Greenbrier & Elk River 3-Truck Shay - LokSn...	Mult*Lead	A_P_	=066	>1005	NC 04	28	F 000	_	_____
<input type="checkbox"/>	 D&RGW 2-Truck Shay - DN142	Mult*Mid	___	=066	>2011		28	F 000	-	_____
<input type="checkbox"/>	 D&RGW 2-6-0 Mogul - TCS-MC6	Mult*Rear	___	=066	>2917		28	F 000	-	_____
<input type="checkbox"/>	 Logging Consist #1	Consist	_P_	>066				F 000	-	_____

Note, in passing, that if you enter the actual Consist Address after pressing the **SELECT LOCO** button on an NCE Handheld Cab, the Command Station does not normally identify the entry as a Consist, although any subsequent speed or function commands sent to the track are interpreted correctly.

Beware of the situation where the definition of a Consist differs between A-Track and the NCE Command Station, as in the original state of Consist 066 (see **Section 6.12**). Here, if Loco 2917 is selected from an NCE Cab, it appears in the A-Track Item List that the Consist is being controlled via its Rear Loco, whereas, in actuality (and from the NCE Command Station point of view, which has Loco 0606 assigned as the Rear Loco), Loco 2917 is operating as an independent Locomotive –

<input type="checkbox"/>	 Greenbrier & Elk River 3-Truck Shay - LokSn...	Mult*Lead	_P_	=066	>1005		28	F 000	-	_____
<input type="checkbox"/>	 D&RGW 2-Truck Shay - DN142	Mult*Mid	___	=066	>2011		28	F 000	-	_____
<input type="checkbox"/>	 D&RGW 2-6-0 Mogul - TCS-MC6	Mult*Rear	A_	=066	>2917	NC 04	28	F 000	-	_____
<input type="checkbox"/>	 Logging Consist #1	Consist	_P_	>066				F 000	-	_____

Conversely, attempting to control Loco 0606 from A-Track (using Operate and an on-screen controller) will fail, since this Loco is assigned to Consist 066 in the Command Station, and will not respond to commands issued by A-Track using the Loco's own address (0606).

If you wish to control a complete Consist directly from A-Track, then the Consist must first be activated from A-Track, as described in **Sections 6.11** and **6.12**. You can then allocate either the Consist Item itself or any of its Assigned Locomotives (Multiples) – including any Mid Loco – to an on-screen (Console) controller in order to achieve the desired result (see **Section 6.9**).

Note also that it is not possible to allocate any Consist (or an individual Multiple) to an NCE Handheld Cab from the A-Track Item List. Allocation to an NCE Cab has to be done from the Cab itself using the **SELECT LOCO** button.

If any of the Lead, Mid, or Rear Locos of a Consist defined in the Command Station have **not** been assigned to a Consist in the Item List, then you can allocate any of these Locos to an NCE Cab from A-Track. In such cases, the Command Station will recognise the allocation of the complete Consist (and not just the single Loco) to the relevant NCE Cab, and exercise the required control over the whole Consist.

7 ACCESSORY ITEM OPERATIONS

7.1 Accessories – Operation and Parameters

As introduced in **Section 5.1**, Items in A-Track can also hold the parameters of decoders designed to operate model railroad layout accessories such as turnout machines and signal arrays. At present, there are not many signal controllers on the market, so support in A-Track is currently directed towards DCC decoders intended to drive a variety of turnout motors. Although A-Track will handle accessory decoders from a range of suppliers, including Digitrax and Lenz, specific features are implemented to support the range of accessory decoders produced by NCE Corporation.

Note : If you load an Item List containing Accessory Items defined in an earlier version of A-Track, the parameters of all Accessory Items will be updated to accommodate some expanded features, and you will be asked to re-save the Item List (preferably under a **new filename**) before proceeding any further –

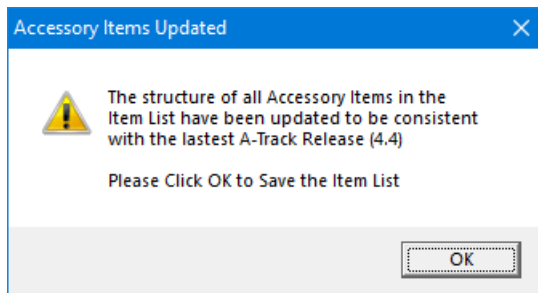

For an **Accessory** Item held in an Item List, the **Identity** Parameter Tab of the Edit CVs window contains the same information as any other Item, as shown below –

Item #7 - Addr 0260 - Configuration Variables

Item Description Accessory Decoder - Wangrow SM-104

Program CVs
Read/Verify CVs
Copy All CVs
Paste Main CVs
Paste Exten'd CVs
Paste Index'd CVs
Update Item
Close

Identity **Config**

Item Type
 Accessory
 Consist
 Locomotive
 Multiple
 None

Acc'y Decoder Addr 0260
 Extended Address ====
 Consist Address ===
 User Identifier #1 000
 User Identifier #2 000
 Manufac Version No. 012
 Manufacturer ID 012

Not Allocated 00 Edited Not Prog'd

CV	0x	1x	2x	3x	4x	5x	6x	7x	8x	9x	10x	11x	12x
0	000	255	255	255	000	000	000	000	000	000	000	000	000
1	004	255	255	255	000	000	000	000	000	000	000	000	000
2	214	255	255	255	000	000	000	000	000	000	000	000	000
3	000	255	255	000	000	000	000	000	000	000	000	000	000
4	000	255	255	000	000	000	000	000	000	000	000	000	000
5	000	000	255	000	000	000	000	000	000	000	000	000	000
6	000	000	255	000	000	000	000	000	000	000	000	000	000
7	012	255	255	000	000	000	000	000	000	000	000	000	000
8	012	255	255	000	000	000	000	000	000	000	000	000	000
9	004	255	128	000	000	000	000	000	000	000	000	000	000

A new Blank Item is initialised as an Accessory by clicking on the Accessory option under **Item Type**, and then entering a suitable **Description**, possibly describing the function or location of the Accessory on the layout, followed by an **Acc’y Decoder Address**, in the appropriate textboxes.

In the original definition for the format of Accessory Decoder parameters in the NMRA DCC Standards and Recommended Practices, valid Accessory Decoder Addresses range from 1 to 511. Each Accessory Decoder is assumed to have four pairs of Outputs which can be switched ‘On’ or ‘Off’, ie. when one output of an output pair is ‘On’, the other is ‘Off’, and *vice versa*.

Each Output Pair is assigned an address, based on the allocated Decoder Address, which you can use to send a command, from a Handheld Controller, for example, to change the state of that Output Pair. Details of these Output Pairs can be viewed by clicking on the **Config** Parameter Tab as shown in the example below, where, in the **Outputs 1 – 4 Address + Time On** area, the address of Output Pair #4 (1040) is calculated by multiplying the Decoder Address (0260) by 4, and then subtracting 1, 2, or 3 from this value to obtain the addresses of Output Pairs #3, #2, and #1, respectively –

CV	0x	1x	2x	3x	4x	5x	6x	7x	8x	9x	10x	11x	12x
0	000	255	255	255	000	000	000	000	000	000	000	000	000
1	004	255	255	255	000	000	000	000	000	000	000	000	000
2	195	255	255	255	000	000	000	000	000	000	000	000	000
3	000	255	255	000	000	000	000	000	000	000	000	000	000
4	000	255	255	000	000	000	000	000	000	000	000	000	000
5	000	000	255	000	000	000	000	000	000	000	000	000	000
6	000	000	255	000	000	000	000	000	000	000	000	000	000
7	012	255	255	000	000	000	000	000	000	000	000	000	000
8	012	255	255	000	000	000	000	000	000	000	000	000	000
9	004	255	128	000	000	000	000	000	000	000	000	000	000

As can be seen above, each **Output Address** value has an associated textbox (to its right) where you can set the period for which either output of each pair will stay in the ‘On’ state following receipt of an activating command. The value to be entered into a **Time On** textbox for a given output duration is set by the decoder manufacturer (commonly as units of 0.1 second).

In addition, you can select which of the decoder’s Auxiliary Inputs, connected to external pushbuttons, for example, will operate the corresponding Accessory Output when activated (two buttons per Output Pair), by clicking to tick the appropriate checkbox in the **Auxiliary Input Activation** area.

All of these parameters are stored in the Accessory Item's Configuration Variables, with the Decoder Address stored in two parts in CV01 and CV09, and the Decoder Configuration set to a standard value of 128 in CV29 to indicate an Accessory Decoder. The Auxiliary Input Activation settings are stored as individual bits in CV02, and the four Time On values in CV03, CV04, CV05, and CV06, respectively.

Although the NMRA DCC Standards and Recommended Practices generally assume that accessory decoders (like those for locomotives) will have their Address, at least, programmed on a separate Program Track, this is seldom a practical proposition since a particular decoder is likely to be wired directly (and permanently) to both the Mainline Track and to the turnout motors or other accessories which it is intended to control, and to be located near to the accessories rather than to a Program Track.

Hence, original-style accessory decoders such as the Wangrow SM-104 shown in the example above, or the similar Digitrax DS54, are now regarded as obsolete, and most manufacturers now produce accessory decoders which are designed to have their Addresses, and any other parameters, programmed directly from the Mainline Track in conjunction with switch settings on, or special temporary wired connections to, the decoder itself.

Also, instead of having a fixed set of four output pairs, linked to a common Address, a range of accessory decoder types are now produced by several manufacturers with between 1 and 8 output pairs, together with the facility to allocate separate, independent Addresses to each output pair. An attempt to reflect this situation has been made in the latest revisions of the NMRA DCC Standards and Recommended Practices which extend the range of valid Accessory Addresses to be from 1 to 2044 (4 times 511) with the intention of allowing an Address to be allocated to an individual Output by setting the decoder Configuration appropriately. Clicking the **Output Addressing** checkbox in the **Parameters** section will (in theory) enable this feature (by setting bit 6 of CV29). This will also change the decoder address textbox caption on the **Identity** Parameter Tab from **Acc'y Decoder Addr** to **Acc'y Output Addr**.

However, the method of allocating an Address to a specific Output is not clearly defined within the NMRA publications, so that the decoder manufacturers have largely adopted their own mechanisms to allocate Addresses to accessory decoders, and to program or set other parameters without, in general, making explicit reference to the set of Configuration Variables defined by the NMRA.

Hence, when you set up an Item to represent one of these modern accessory decoders, you should click to tick the checkbox labelled **Program on Main Track (Manuf Specific)** in the **Programming** area. This will automatically set **Output Addressing** mode, and then disable that checkbox so that the mode cannot be deselected by accident. If this is an Accessory decoder manufactured by NCE, then tick the **NCE** checkbox as well – and the **Mark 2** checkbox if it is one of NCE's more recent products (eg. Switch-It Mk2).

Two further Parameter Tabs labelled **Addrs** and **Names** will then be displayed, and will allow you to allocate up to eight **Output Addresses** to the Accessory, together with several other options, and then to give each Output Address a descriptive **Name** which is representative, perhaps, of the layout location of a turnout to be controlled via that address.

When setting up a new Item as this type of Accessory, after entering the Item Description there is no need to enter an Acc'y Decoder Address (leave it at the default

value of 0001), and you can proceed directly to the **Config** Parameter Tab where you should click the **Program on Main Track (Manuf Specific)** checkbox to open the **Addr**s and **Names** Parameter Tabs. An example is shown below for a DCC-Concepts Cobalt AD4 Accessory Decoder –

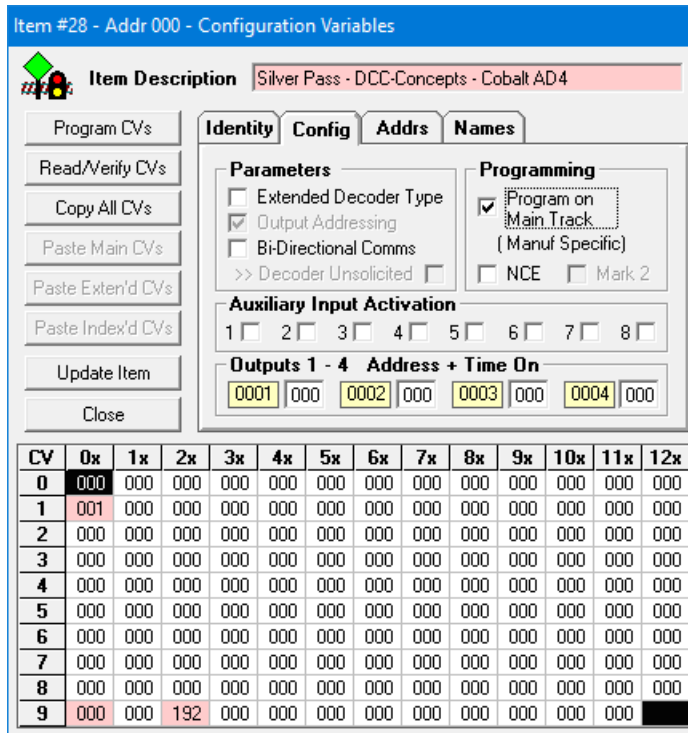

Note that, for consistency with the NMRA DCC Recommended Practices, the set of Output Addresses directly associated with the default Address (0001 to 0004), are shown by A-Track on the **Config** Parameter Tab, as above. Generally, these Addresses will **not** correspond to the actual Output Addresses finally allocated to the decoder using the programming mechanisms defined by the decoder manufacturer and so can be ignored in respect of decoder operation.

Clicking on the **Addr**s Parameter Tab allows you to enter addresses for up to eight individual decoder output pairs.

Your first action should be to select the number of output pairs provided by the particular decoder associated with this Item, by clicking on the down-arrow (▼) at the end of the **Number of Outputs** listbox and then clicking on the appropriate number in the drop-down list (for a DCC-Concepts Cobalt AD4 Accessory decoder used for this example, the number will be **4**) –

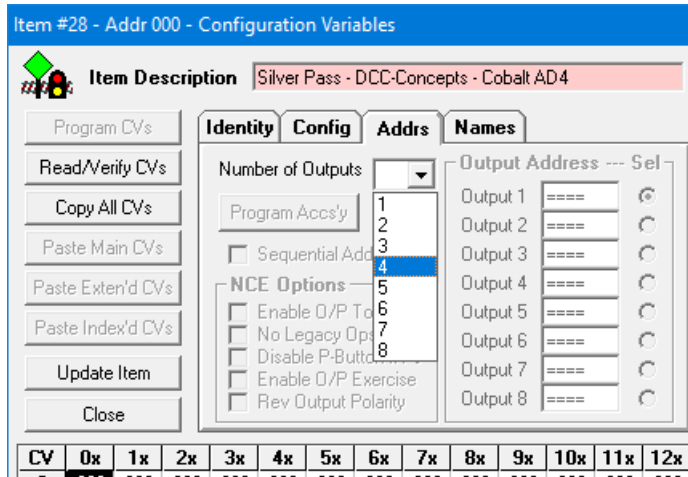

This action will enable the corresponding number of Output Address textboxes, and will fill them with sequential Output Address values calculated from the current Decoder Address (0001 here) as entered on the **Identity** Parameter Tab –

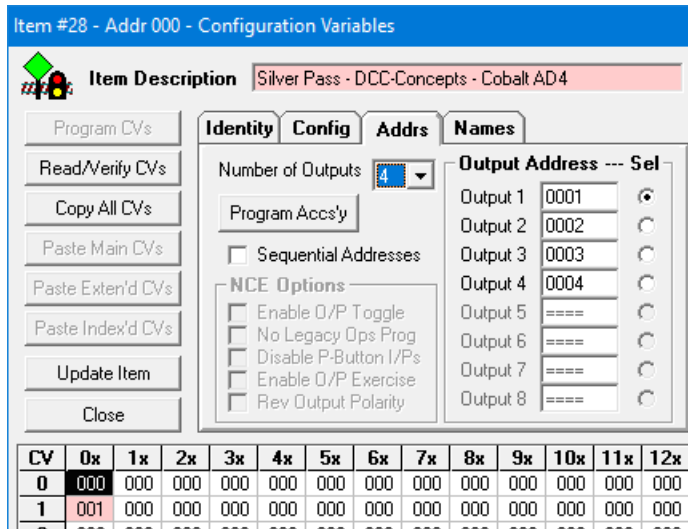

You can now enter the set of Output Addresses that you want for the Item into the enabled textboxes, in accordance with any rules or limitations set out by the manufacturer of the target decoder eg. as a group of sequential values, or as several independent addresses.

In the example below, after clicking in the **Output 3** textbox, an address of **143** has been entered, followed either by a press on the **Enter/Return** key, the **Tab** (↹) key, or a click on any other textbox, option button, or checkbox. In this case, the **Sel** option button for Output 3 has been clicked to select this address as the current active address for the Accessory Item –

Item #28 - Addr 000 - Configuration Variables

Item Description Silver Pass - DCC-Concepts - Cobalt AD4

Program CVs

Read/Verify CVs

Copy All CVs

Paste Main CVs

Paste Exten'd CVs

Paste Index'd CVs

Update Item

Close

Identity **Config** **Addr** **Names**

Number of Outputs 4

Program Acc's'y

Sequential Addresses

NCE Options

Enable O/P Toggle

No Legacy Ops Prog

Disable P-Button I/Ps

Enable O/P Exercise

Rev Output Polarity

Output Address --- Sel

Output 1 0001

Output 2 0002

Output 3 0143

Output 4 0004

Output 5 =====

Output 6 =====

Output 7 =====

Output 8 =====

CV	0x	1x	2x	3x	4x	5x	6x	7x	8x	9x	10x	11x	12x
0	000	000	000	000	000	000	000	000	000	000	000	000	000
1	036	000	000	000	000	000	000	000	000	000	000	000	000

Valid Output Addresses must lie between 0001 and 2044, so that, if you enter a value outside this range, an error message will be displayed –

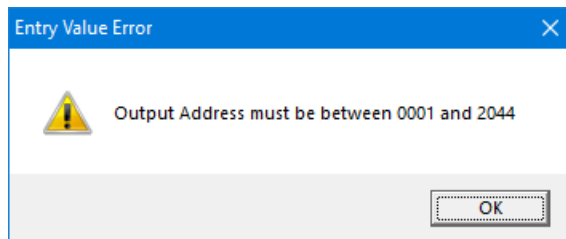

- and the entered value will be reset to 0001.

If you wish to set all of the enabled Output Addresses to a set of sequential values without entering each address individually, then you should click to tick the **Sequential Addresses** checkbox.

Now enter any one of the required address values into the appropriate **Output** textbox and press the **Enter/Return** or **Tab** key. All of the other enabled Output textboxes will then be filled with the required addresses, as shown in the example below. If any of the address values would exceed 2044, then an error message similar to that above will be displayed, and the complete set of sequential addresses will be adjusted to bring them all within the allowed range.

Note that, if you have already entered one of the required sequential addresses without having ticked the Sequential Addresses checkbox, simply click on the checkbox to tick it now, then click on the entered address to highlight it, followed by a press of the **Enter/Return** or **Tab** key –

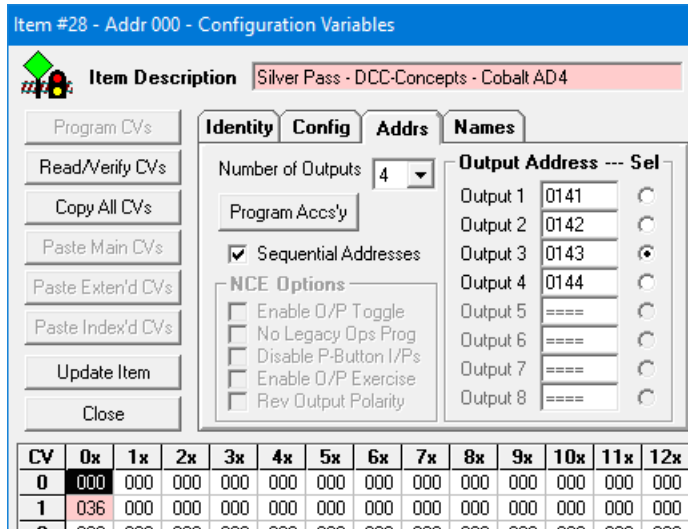

Although most manufacturers of accessory decoders do not make any reference to CV values as far as addresses are concerned, A-Track will display the currently selected Output Address as the **Acc’y Output Addr** on the **Identity** Parameter Tab, and will use its value to update the **Decoder Address** in CV01/CV09 (to 036/000 here), together with the related group of “Output Addresses” on the **Config** Parameter Tab, as shown below, in order to maintain consistency, as far as possible, with the NMRA DCC Recommended Practices. Note that these updates within the Item have no effect on the way the real accessory decoder is handled by A-Track, using the specific programming and operating mechanisms defined by the particular decoder manufacturer (see the following **Sections 7.3** and **7.5** on programming accessory decoders).

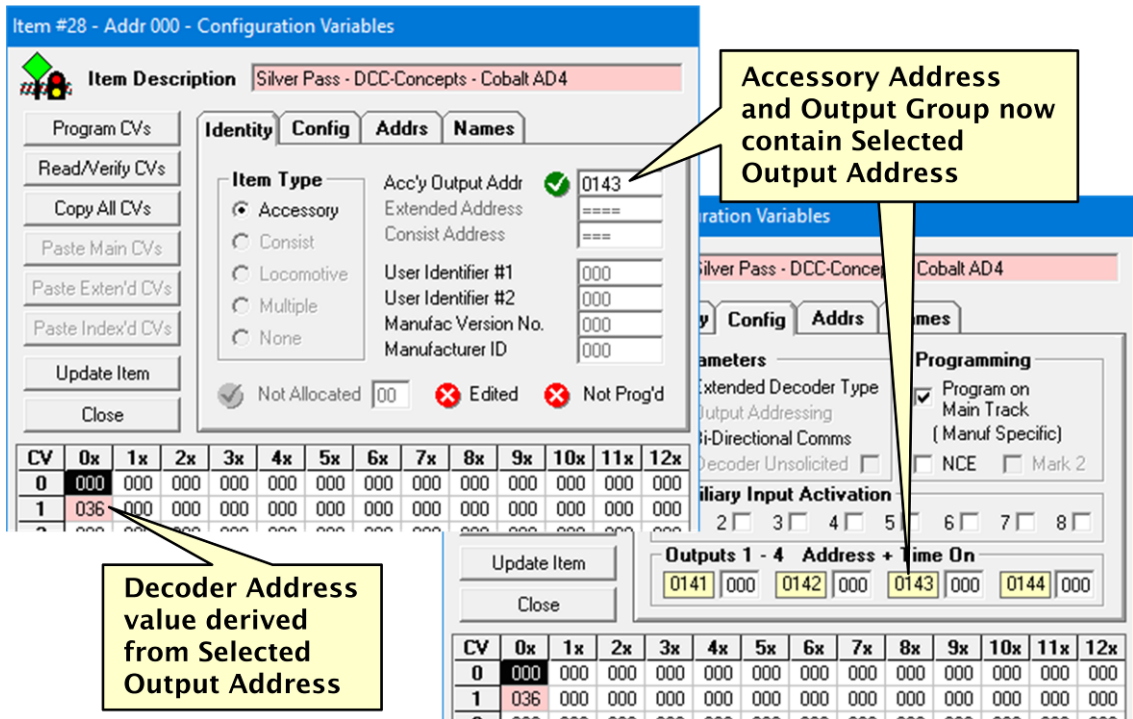

If you enter a new value in the **Acc’y Output Addr** textbox on the **Identity** Tab then this value will be transferred to the currently-selected **Output Address** on the **Addr** Tab, as well as updating the **Decoder Address** and the addresses shown on the **Config** Tab. Be aware that, if the **Sequential Addresses** checkbox is ticked, then *all* Output Addresses will be updated as well as the selected, active Address.

Hence, it is recommended that you leave the **Acc’y Output Addr** value strictly alone, and amend all **Output Address** values on the **Addr** Parameter Tab.

Returning to the initial setup of a new Accessory Item, if the target decoder is an accessory decoder manufactured by NCE Corporation, then, as well as ticking the **Manuf Specific** checkbox in the **Programming** area, you should also tick the (now enabled) **NCE** checkbox, together with the **Mark 2** checkbox if it is one of NCE’s more recent products (eg. Switch-It Mk2).

As before, this action will enable display of the **Addr** Parameter Tab but, when you click on the Addr Tab and, for example, select the **Number of Outputs** as **1** from the drop-down list, only two of the eight **Output Address** textboxes will be shown, together with two additional sets of options, **NCE Options** and **NCE Timing**, which are now enabled –

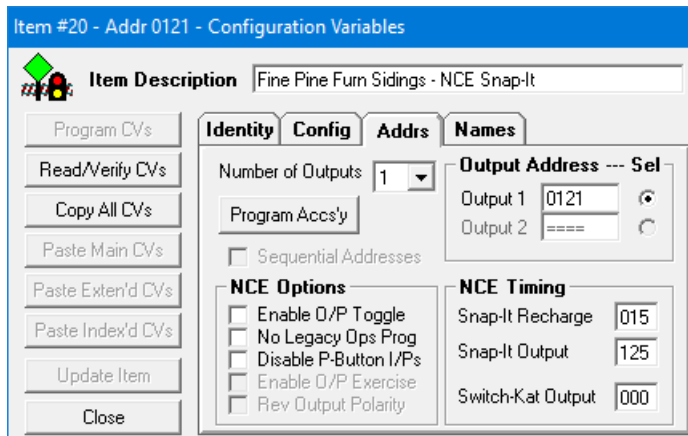

The **NCE Timing** parameters shown here apply only to NCE Snap-It or Switch-Kat accessory decoders, which have only a single Output Address. A similar, smaller parameter panel is displayed for an NCE QSnap Mk2 accessory decoder, where the **Number of Outputs** is set to **4**, and four **Output Address** textboxes are shown –

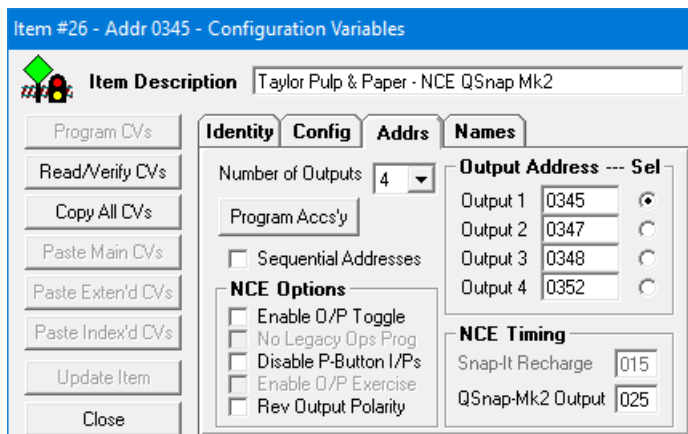

If you set the **Number of Outputs** to any value other than **1** or **4**, the NCE Timing panel will be removed, with the **Output Address – Sel** panel expanding to show all eight Output Address textboxes again –

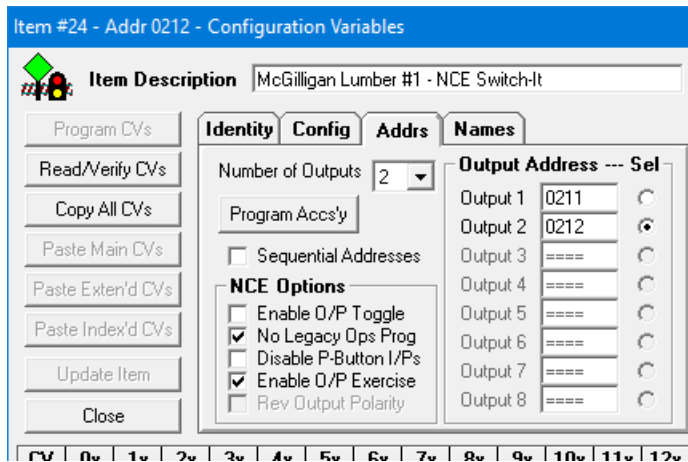

Hence, as in the example above, if the Item being set up is intended to represent an NCE Switch-It accessory decoder, with two Output Addresses, selecting **Number of Outputs** as **2**, and entering the desired address values, leaves the **Addr**s Parameter Tab as shown.

The number (and type) of options available in the **NCE Options** area depends on the type of NCE accessory decoder which is, in turn, set by the number of outputs selected. A-Track assumes that if a single output is selected then the decoder is either an NCE Snap-It or Switch-Kat, if two outputs an NCE Switch-It, if four outputs (and **Mark 2** selected) then an NCE QSnap, and if eight outputs then it is an NCE Switch-8. If any other number of outputs is selected, with or without **Mark 2**, then A-Track assumes that the **NCE** and/or **Mark 2** checkboxes were ticked in error, and the **NCE Options** and **Timing** are disabled. Some further examples of NCE accessory decoder Options are shown below –

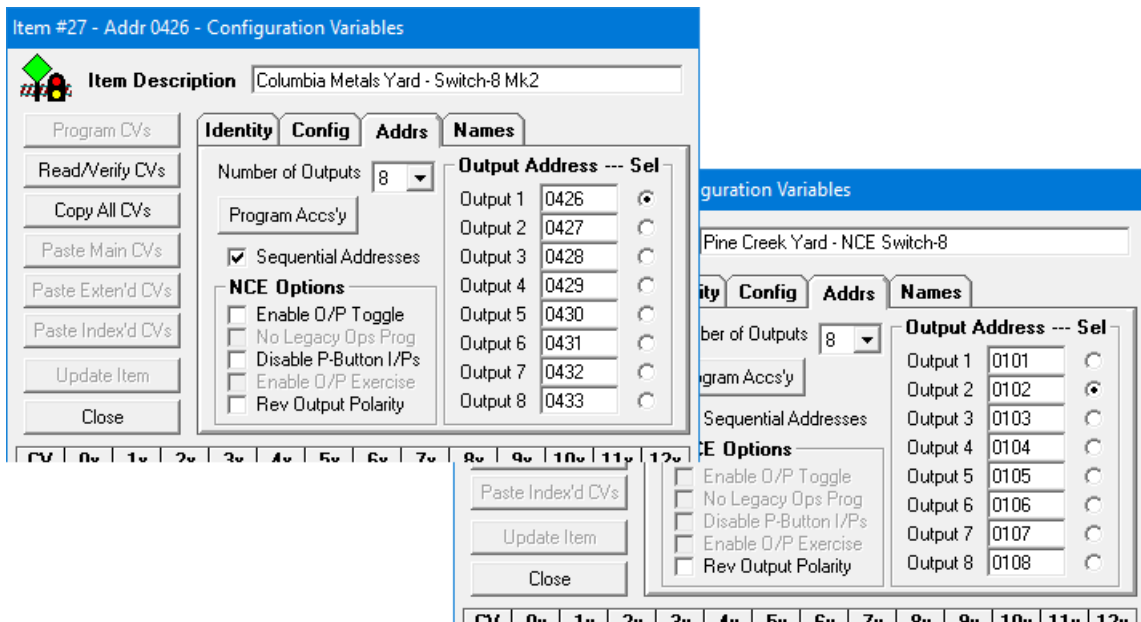

Note that some of the NCE Options apply to individual outputs (such as **Rev Output Polarity** for an NCE Switch-8), whereas others apply to the whole decoder (such as **No Legacy Ops Prog** for an NCE Switch-It or Snap-It), and, hence, remain in force whichever Output Address is selected as active. You should refer to the relevant NCE technical documentation for each decoder type for full details of how each applicable option affects operation of the decoder.

Unlike other manufacturers, NCE Corporation makes use of Configuration Variables, in the range of CV545 to CV580 (shown in the CV Grid as CV33 to CV68), to hold the operating parameters of their range of accessory decoders. CV515 (CV03) is also used to hold the **Output On-Time** for the Switch-Kat single-output decoder.

Note, however, that it is not possible to read back any of the set values of these CVs by connecting the decoder to the Program Track and using Read/Verify. The NCE accessory decoder CVs can only be programmed using Operations Mode (Program on Main Track) when the NCE Command Station is connected to the Mainline Track, as covered in the following **Sections 7.3** and **7.5**.

Having set up the Item's Output Addresses, plus any of the NCE Options, clicking on the **Names** Parameter Tab will allow you to enter a description for each Output Address, generally representing the location of the turnout to be controlled from each decoder output. Each description can have a **maximum of 24 characters**.

Using an NCE Switch-It decoder as an example, the default descriptions given by A-Track to the two Output Addresses are 'Output 1' and 'Output 2' -

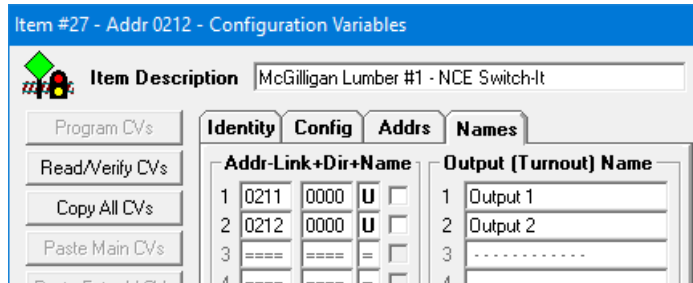

Click in the first **Output (Turnout) Name** textbox to highlight 'Output 1', type a description, press the **Tab** (↹) key to complete the operation and to highlight the second Name textbox, then repeat the sequence to enter a replacement description for 'Output 2', as shown below -

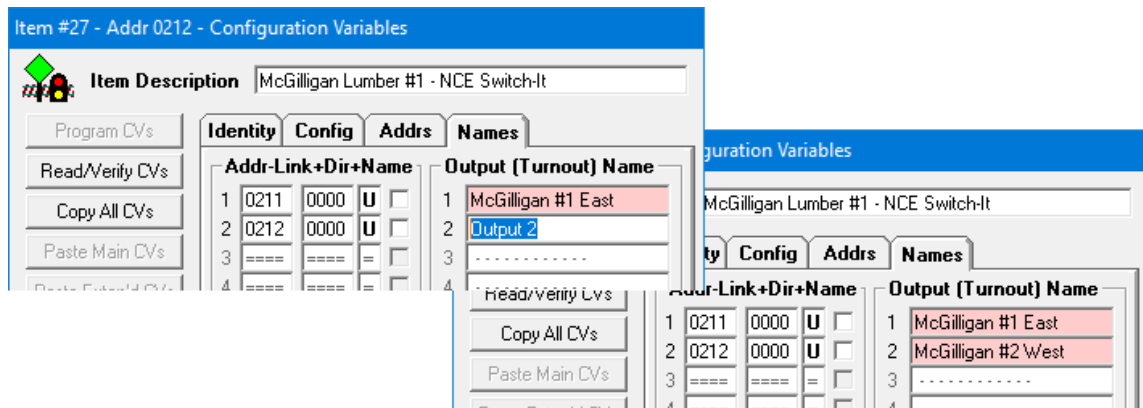

When the setup of your new Accessory Item is completed, or you have made any changes, you should, as usual, click **Update Item** to save the Accessory back to the Item List. If you click **Close**, you will be prompted to either save or discard the edited Item before the Edit CVs window is closed.

The display of an Accessory's key parameters in the Item List is a little different to those of Locomotive Items, as shown in the example below –

The screenshot shows a window titled 'Item List' with a list of accessories. The list has columns for the accessory name, type, decoder address, output address, and output state. A callout box labeled 'Accessory Items' points to the first few rows. Another callout box labeled 'Output States from Last-Sent Commands' points to the output state column. Two callout boxes at the bottom identify the 'Current Accessory Decoder Address' (the primary address column) and the 'Current Selected Accessory Output Address' (the extended address column).

Accessory Name	Type	Primary Address	Extended Address	Output State
Pine Creek Yard - NCE Switch-8	Access'y	_P_ 0026	>0102	12045000
Fine Pine Furn Sidings - NCE Snap-It	Access'y	_P_ 0031	>0121	1
Heath Sawmill Siding #3 - NCE Switch-Kat	Access'y	_P_ 0031	>0122	0
High Peak - Digitrax DS52	Access'y	_P_ 0033	>0131	12
Silver Pass - DCC-Concepts - Cobalt AD4	Access'y	_P_ 0036	>0141	0000
Pine Creek West - Lenz LS150	Access'y	_P_ 0038	>0151	100050
Forest Flat - Tam Valley Quad-PIC	Access'y	_P_ 0051	>0201	0230
McGilligan Lumber #1 - NCE Switch-It	Access'y	_P_ 0053	>0212	00
McGilligan Lumber #2 - NCE Switch-It Mk2	Access'y	_P_ 0056	>0221	00

The Decoder Address of the Accessory is shown in the Primary Address column, with the currently selected Output Address shown in the Extended Address column. Accessories using Manufacturer Specific programming are identified by placing a '>' symbol in front of the Output Address, whereas older style decoders using NMRA standard addressing will have the '>' symbol preceding the Decoder Address.

The rightmost Function 1-8 column is used to show the state of each Accessory Output which resulted from the last issued command.

If you are using an NCE Power Pro Command Station, then this Output data is obtained from the Command Station, so reflects commands sent from both A-Track and Handheld Cabs. However, such data is not available from an NCE Power Cab system, so the column only shows data sent from A-Track and saved within the Accessory Items in the Item List. See the following **Section 7.4** on Accessory Control for further details regarding the monitoring of Output states.

7.2 Accessory Decoders – Linking Turnouts

As well as holding the turnout location descriptions, the **Names** Parameter Tab of an Accessory Item also allows you to **link** pairs of turnouts. Linking can be done in two different ways. Firstly, if each turnout is driven from a separate Output Address (from the same or another accessory decoder) then, when A-Track issues a command to throw one turnout of the linked pair, a command is automatically generated to throw the second turnout. **Note** : this **only** occurs when A-Track sends the turnout command – **not** when the command is sent from a Handheld Cab.

Alternatively, the two turnouts can be driven from a single accessory decoder output (where the manufacturer states that this can be done), so that they share an Output Address. In this case, A-Track (or a Handheld Cab) has only to issue a single command to throw both turnouts together.

Linking of turnouts can best be demonstrated through a simple example where two pairs of turnouts provide two crossovers between parallel tracks –

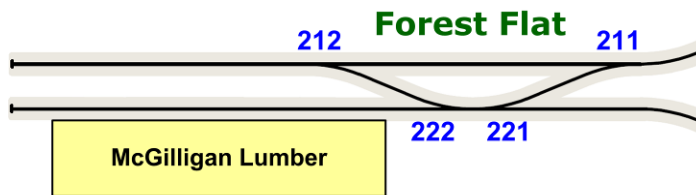

For the purposes of the example, the two turnouts with addresses 0211 and 0212 will be controlled using an NCE Switch-It decoder (with an Item Description of 'McGilligan Lumber #1'), and the other pair with addresses 0221 and 0222 using an NCE Switch-It Mk2 decoder ('McGilligan Lumber #2').

For the present, we will just leave the second (Switch-It Mk2) Accessory Item in its default state after the Output Addresses have been set, so that its Output (Turnout) Names are 'Output 1' and 'Output 2' (see the preceding **Section 7.1**).

If, on the Item's **Names** Parameter Tab, you click to tick any of the **Name** checkboxes at the righthand side of the **Addr-Link+Dir+Name** section, the Name of any turnout (Output) linked to that Output Address is shown. In this case, all such Names are shown as 'Not Linked' –

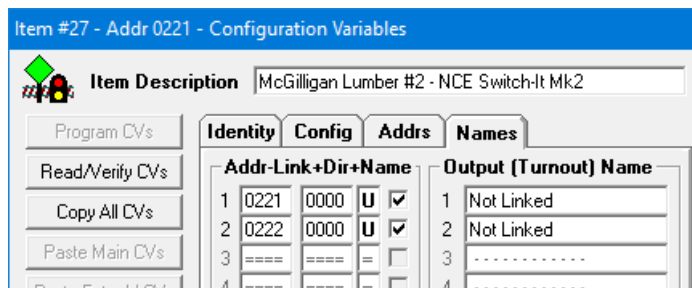

Important Note : Before setting up a link between any two turnouts, ensure that the **only** Edit CVs window which is open is that of the Accessory Item which contains one (or both) of the turnouts. All other Edit CVs windows should be closed.

After selecting the **Names** Parameter Tab in the Edit CVs window of the first (Switch-It) Item, click in the **Link** textbox next to address 0211 and type in '221' as the turnout (Output Address) to be linked -

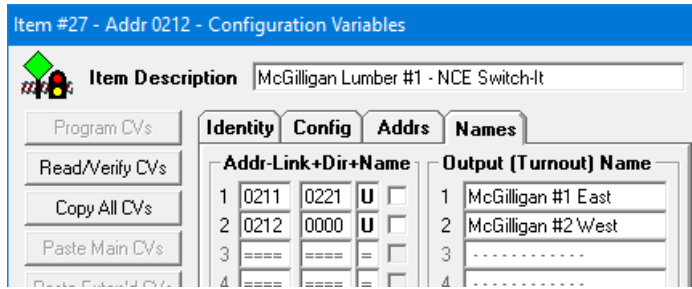

Next, press the **Tab** (↵) key to highlight the small **Dir** textbox to the right of the entered link Address, and press the 'N' key on the keyboard to set the link as 'Normal', replacing the current letter 'U' (which signifies the turnout as 'Unlinked') with the letter 'N'. This means that when turnout 0211 is thrown, turnout 0221 will be thrown in the same direction (and *vice versa*). Alternatively, you could press the 'R' key on the keyboard, putting 'R' in the textbox, and setting the link as 'Reverse' where the turnouts move in opposite directions when either is thrown. Press the **Tab** key again to complete the linkage, leaving the linked Output Address (0211) highlighted in **orange** -

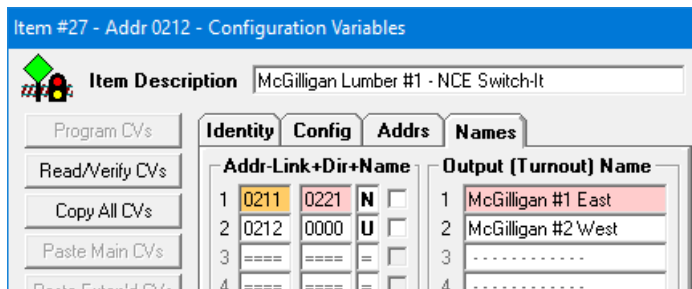

Repeat the sequence of actions to link the second turnout (Output Address) 0212 to Output Address 0222. If the **Name** checkboxes are then ticked, default linked Names ('Output 1' and 'Output 2') will be displayed, since no descriptions have yet been entered for the Output Addresses of the second (Switch-It Mk2) Item -

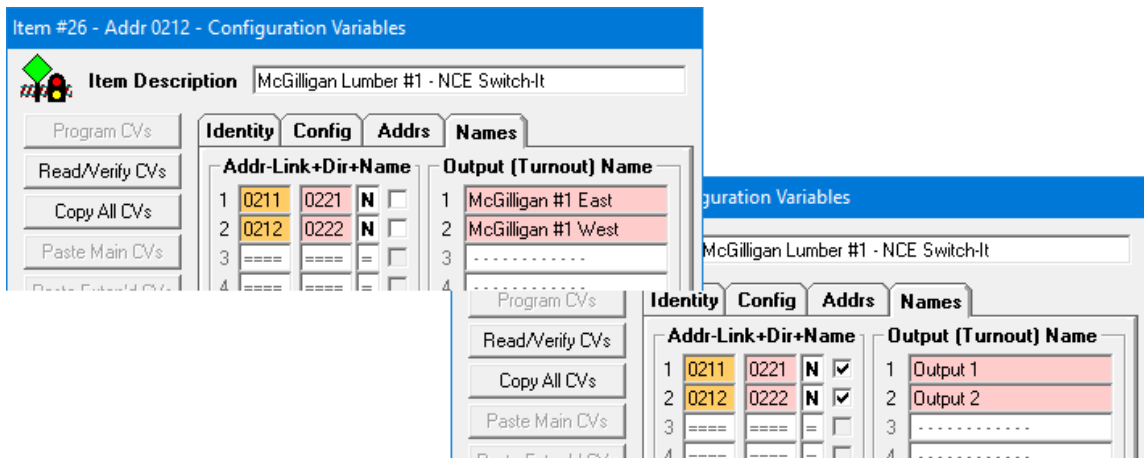

Now, click **Update Item** to save all of the changes within this Accessory Item back to the Item List, then open the Edit CVs window for the second (Switch-It Mk2) Accessory Item and click the **Names** Parameter Tab. Both Output Addresses are highlighted in **orange** to show that they are linked, with the linked addresses shown in the adjacent **Link** textboxes. Ticking each of the **Name** checkboxes in the **Addr-Link+Dir+Name** section then reveals the Names of the linked Output Addresses in the first (Switch-It) Item –

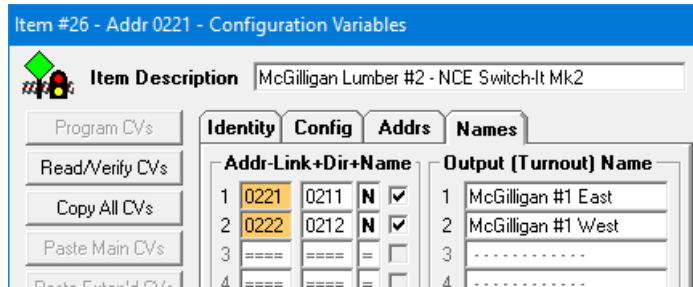

If we now click to untick both of the **Name** checkboxes, we can enter appropriate descriptions for each Output Address in this Accessory Item, following the sequence shown in **Section 7.1** for the first (Switch-It) Item.

After doing this, and clicking **Update Item** to save the changes to the Item List, if we view the **Names** Parameter Tab in the Edit CVs window of the first (Switch-It) Accessory Item, these new Output (Turnout) Names will be displayed as linked Names, as shown below –

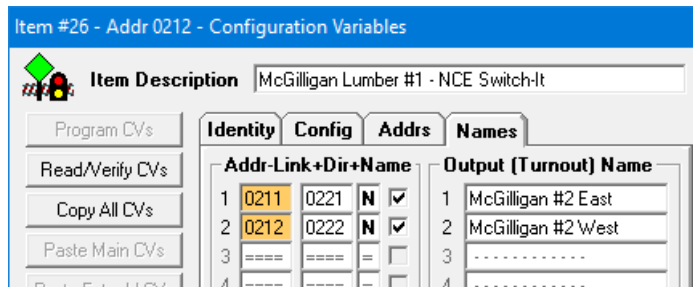

Note : Although you can edit the assigned Output (Turnout) Names on the **Names** Parameter Tab of an Accessory Item at any time, you cannot edit the *linked* Names when they are displayed, since they belong to a different Item.

If both Outputs to be linked are located within the same Accessory Item, then setting the link is even simpler. In the Edit CVs window, click on the **Names** Parameter Tab, then click in the **Link** textbox next to the first Output Address to be linked and type in the second Output Address. Press the **Tab** key to highlight the small **Dir** textbox to the right of the entered link Address, and press the 'N' key on the keyboard to set the link as 'Normal', or the 'R' key to set it as 'Reverse', and finally press the **Tab** key again.

Both selected Output Addresses should now be highlighted in **orange** and, if you tick both of the **Name** checkboxes, you should see the relevant linked Names in the **Output (Turnout) Name** textboxes, as shown in the example below –

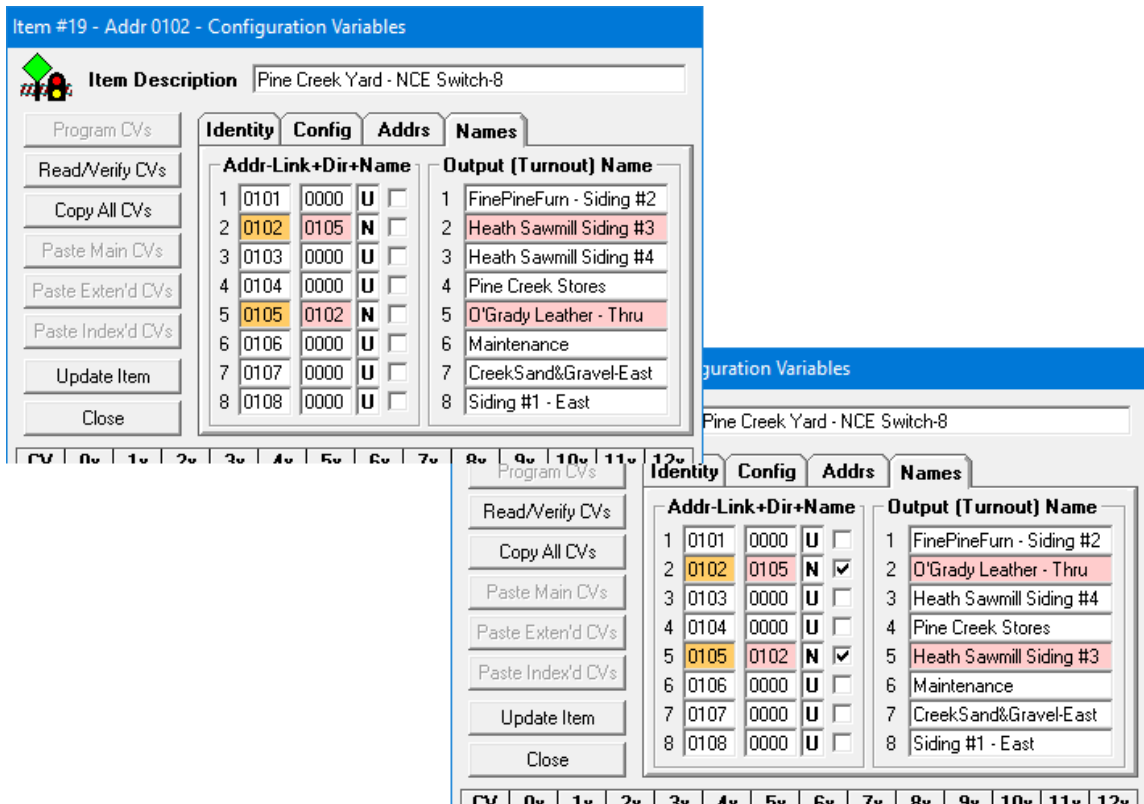

Removing a link, once it has been set, is done by opening the Edit CVs window of the Accessory Item containing either of the linked Outputs. Click on the **Names** Parameter Tab and then in the **Link** textbox containing one of the linked addresses. Type '0' (zero) on the keyboard to set the link address to 0000, then press the **Tab** key. Alternatively, you can click in the small **Dir** textbox and press the 'U' key followed by **Tab**. Either action will clear the link in this Item, then clicking **Update Item** will update the Item List, fully clearing the linkage if the second Output Address was in another Accessory Item.

Where you wish to link two turnouts by driving them from a **single** decoder output, ie. using a common Output Address, then there is actually no necessity to involve A-Track at all. Just connect the turnout motors to the same accessory decoder output and issue a single command to the relevant Output Address to throw both turnouts.

However, if you want to use A-Track to monitor the positions of such linked turnouts automatically, in connection with a layout Mimic Diagram (see **Chapter 8**) and by using an NCE Auxiliary Input Unit (AIU) as described in **Section 8.4**, then the two turnouts need to be identified separately.

This facility is set up on the **Names** Parameter Tab by entering an address into the **Link** textbox next to the relevant Output Address with a value equal to the Output Address **plus 3000** (normal accessory addresses have a maximum value of 2044).

As an example, suppose we have a pair of turnouts to switch between sidings at the end of a yard, and we want to drive the turnout motors from the same NCE Snap-It accessory decoder whose single output has been assigned the address 0121 -

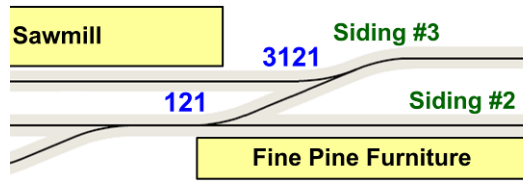

Open the Edit CVs window for the relevant Item, and click on the **Names** Parameter Tab. Click in the **Link** textbox and type in the value '3121' (address + 3000) from the keyboard. Press the **Tab** key to highlight the **Dir** textbox (currently 'U') and, in this case, press the 'R' key to set the link direction as 'Reverse', ie. when turnout 0121 is thrown to the Route (diverging) position, we want turnout 3121 to move to the Normal (straight) position (and *vice versa*) –

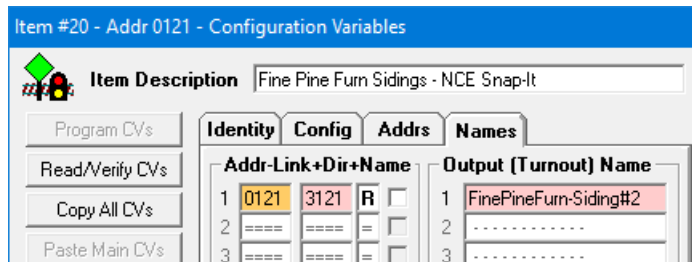

To give the linked turnout 3121 its own description, click to tick the **Name** checkbox, then click in the **Output (Turnout) Name** textbox to highlight the default name ('Linked 1'). Now type your preferred description for the linked turnout to replace the default version, as shown below –

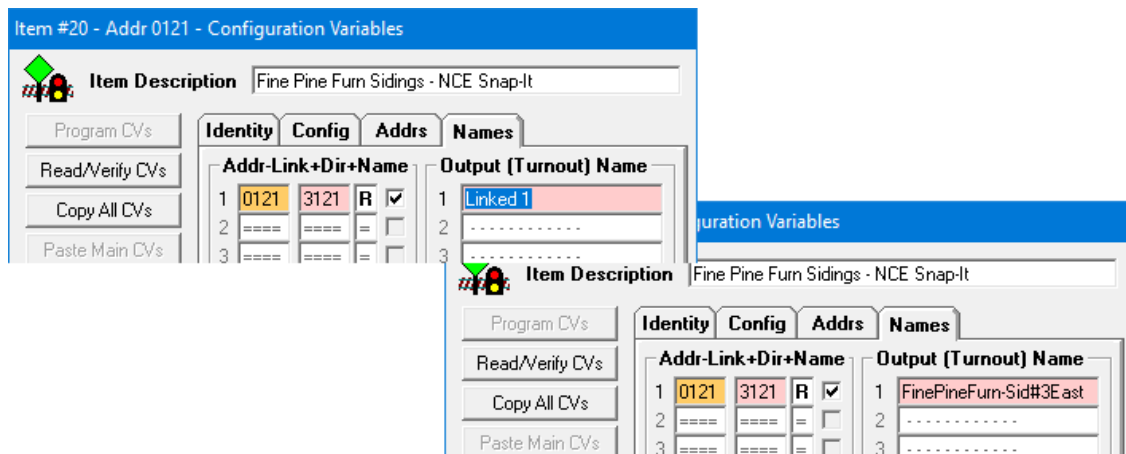

Finally, click **Update Item** to save your edits back to the Item List.

The key point to remember where you have created this type of linkage in A-Track is that you can only send an operate command, from A-Track or a Handheld Cab, to turnout 0121 – never to turnout 3121. The latter is physically connected to the same turnout motor as turnout 0121, so both move together. However, the position of each turnout can be monitored independently using two separate inputs to an NCE Auxiliary Input Unit (AIU), as explained in **Section 8.4**, so that you can verify in A-Track that both turnouts have actually moved as commanded.

7.3 Programming Accessory Decoders – Edit CVs Window

Since an accessory decoder is likely to be wired directly (and permanently) to both the Mainline Track and to the turnout motors or other accessories which it is intended to control, and to be located near to these accessories, it is frequently impractical to attempt to program the address or other parameters of such a decoder using a separate Program Track, as is generally assumed by the NMRA DCC Standards and Recommended Practices.

All available modern accessory decoders which are designed to operate turnouts can have the address of each of their outputs programmed remotely via the Mainline Track. The usual method of doing this is to send an 'Operate Turnout' command from the Command Station to the required output address, while the accessory decoder is configured in programming mode.

The configuration method required to do this is specific to each manufacturer, where techniques include the use of switches or pushbuttons mounted on the decoder, temporarily-fitted wire links or push-on jumpers, or additional temporary connections from the decoder to the Mainline Track while programming takes place.

Of the major accessory decoder manufacturers, only NCE Corporation and Tam Valley Depot currently make use of Configuration Variables (CVs) to program decoder settings remotely via the Mainline Track (Operations Mode programming). The Digitrax DS54 decoder (now superseded) also made use of CVs to hold various parameters, but this approach is no longer used in the newer DS64 decoder. Settings for accessory decoders from other manufacturers are generally programmed directly at each decoder by means of jumper links or sequences of switch operations, possibly in conjunction with accessory operational commands.

Addresses selected for Accessory Items defined in an A-Track Item List, together with some additional parameters, can be programmed into the corresponding decoder, once the decoder is connected to the Mainline Track, in either of two ways, one via the Edit CVs window, as covered in the rest of this section, and the other by issuing Accessory operating commands, which is described in **Section 7.5**.

For the first method, double-click on the Item to open the Edit CVs window, then click on the **Addr**s Parameter Tab. Select the Output Address to be programmed by clicking on the relevant **Sel** option button (Output 3 in the example below), then click the **Program Accs'y** button –

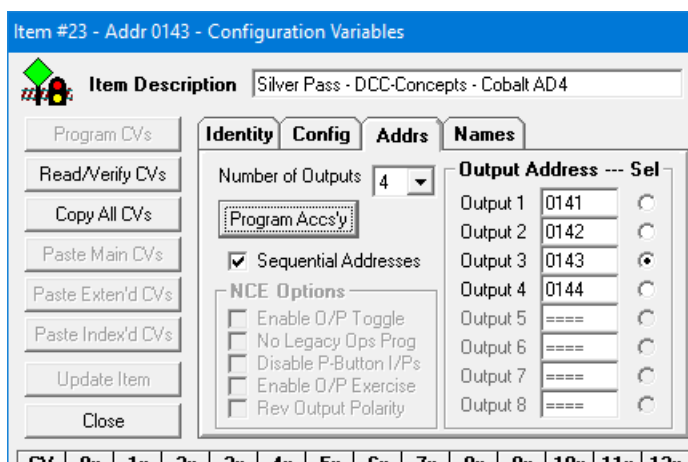

A prompt will appear, reminding you to configure the relevant accessory decoder (connected to the Mainline Track) ready for programming –

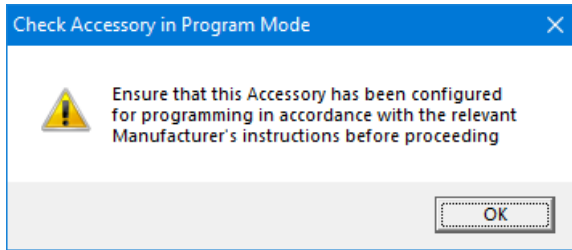

When the decoder is correctly set up, click **OK** to proceed, and to display the **Program CVs** page with all of the necessary options pre-selected. The Decoder Address CVs are highlighted in **yellow**, to indicate programming of an address, although the actual value programmed will be that of the selected Output Address –

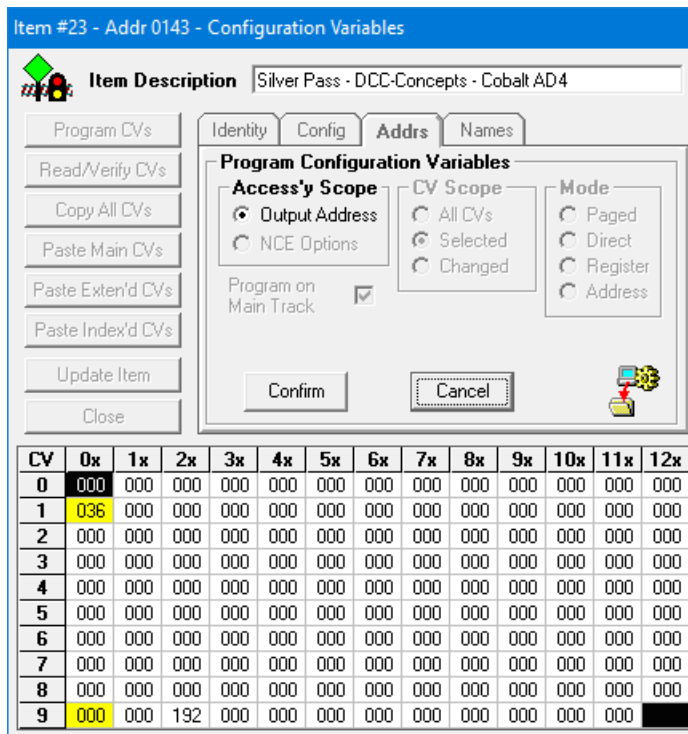

In this case, for a DCC-Concepts Cobalt AD4, a small slide switch on the decoder is moved to the 'Learn' position to enable programming of the Output Address. For this, or any other type of accessory decoder, refer to the supplied manufacturer's documentation for full details of the required configuration.

Click **Confirm** to issue an 'Operate Turnout' command using the selected address. The operation will be confirmed visually by the normal Programming sequence described in **Section 6.7** where CV01 is first highlighted in **red**, and should end with both CV01 and CV09 highlighted in **light green**, together with display of a confirmation message "Programming Completed Successfully" –

Paste Index'd CV's

Update Item

Close

Programming Completed Successfully

Confirm

Finish

CV	0x	1x	2x	3x	4x	5x	6x	7x	8x	9x	10x	11x	12x
0	000	000	000	000	000	000	000	000	000	000	000	000	000
1	036	000	000	000	000	000	000	000	000	000	000	000	000
2	000	000	000	000	000	000	000	000	000	000	000	000	000
3	000	000	000	000	000	000	000	000	000	000	000	000	000
4	000	000	000	000	000	000	000	000	000	000	000	000	000
5	000	000	000	000	000	000	000	000	000	000	000	000	000
6	000	000	000	000	000	000	000	000	000	000	000	000	000
7	000	000	000	000	000	000	000	000	000	000	000	000	000
8	000	000	000	000	000	000	000	000	000	000	000	000	000
9	000	000	192	000	000	000	000	000	000	000	000	000	000

Click **Finish** to return to display of the **Addr**s Parameter Tab.

Where the Accessory Item represents an NCE decoder, additional decoder parameters can be programmed via the Mainline Track using Operations Mode –

Item #27 - Addr 0212 - Configuration Variables

Item Description McGilligan Lumber #1 - NCE Switch-It

Program CV's

Read/Verify CV's

Copy All CV's

Paste Main CV's

Paste Exten'd CV's

Paste Index'd CV's

Update Item

Close

Identity **Config** **Addr**s **Names**

Number of Outputs 2

Program Accs'y

Sequential Addresses

NCE Options

Enable O/P Toggle

No Legacy Ops Prog

Disable P-Button I/Ps

Enable O/P Exercise

Rev Output Polarity

Output Address --- Sel

Output 1 0211

Output 2 0212

Output 3 =====

Output 4 =====

Output 5 =====

Output 6 =====

Output 7 =====

Output 8 =====

CV	0x	1x	2x	3x	4x	5x	6x	7x	8x	9x	10x	11x	12x
0	000	000	000	000	000	000	000	000	000	000	000	000	000
1	053	000	000	000	000	000	000	000	000	000	000	000	000
2	000	000	000	000	001	000	000	000	000	000	000	000	000
3	000	000	000	000	000	000	000	000	000	000	000	000	000
4	000	000	000	000	000	000	000	000	000	000	000	000	000
5	000	000	000	001	000	000	000	000	000	000	000	000	000
6	000	000	000	000	000	000	000	000	000	000	000	000	000
7	000	000	000	000	000	000	000	000	000	000	000	000	000
8	000	000	000	000	000	000	000	000	000	000	000	000	000
9	000	000	192	000	000	000	000	000	000	000	000	000	000

In this example, for an NCE Switch-It Accessory decoder, Output Address 2 (0212) has been selected for programming, together with the required state of the available options in the **NCE Options** section of the Addr's Tab. In this instance, the relevant Configuration Variables have been updated to reflect the selections, so are highlighted in pink, although this would not be the case if no changes had been made in the Edit CVs window after it had been opened.

Programming of the additional NCE decoder parameters should, of course, only be done after programming the NCE decoder Output Address, as described in the previous paragraphs, but is then initiated, as before, by clicking on the **Program Accs'y** button

to open the **Program CVs** page. Clicking on the **NCE Options** button in the **Access'y Scope** area will then highlight the parameter values in the CV Grid in **yellow** (or **orange** where, as in this case, some of the CVs were already marked as 'changed' with a **pink** highlight) –

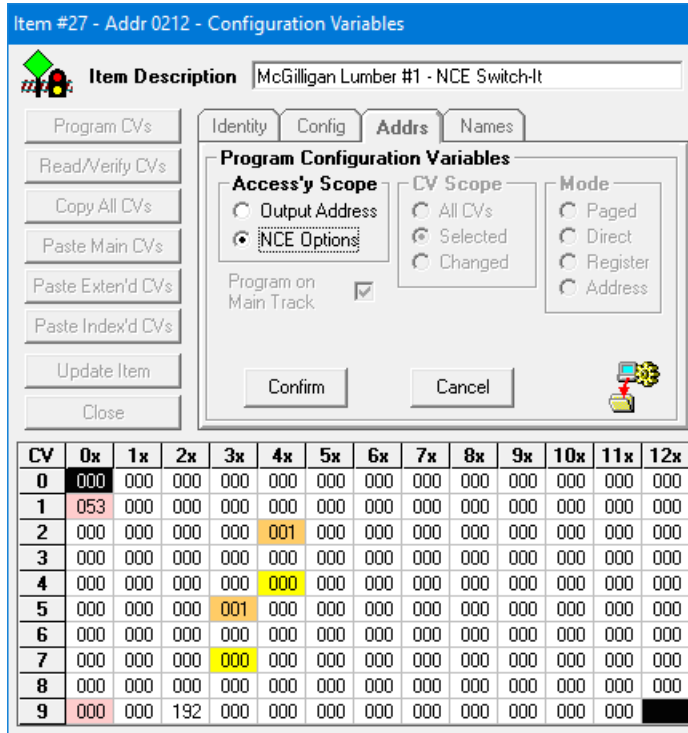

If you do not want to program all of the NCE Options at this time, you can remove the **yellow** or **orange** highlight from those you want to leave as they are, by holding down either **Ctrl** (Control) key on your keyboard and then clicking on the relevant cell in the CV Grid.

If you make a mistake, you can restore the highlight by simply clicking on the CV cell again while continuing to hold down a **Ctrl** key. To assist selection of the correct CV, descriptions of each CV will pop up when you hover the mouse cursor over each cell in the CV Grid –

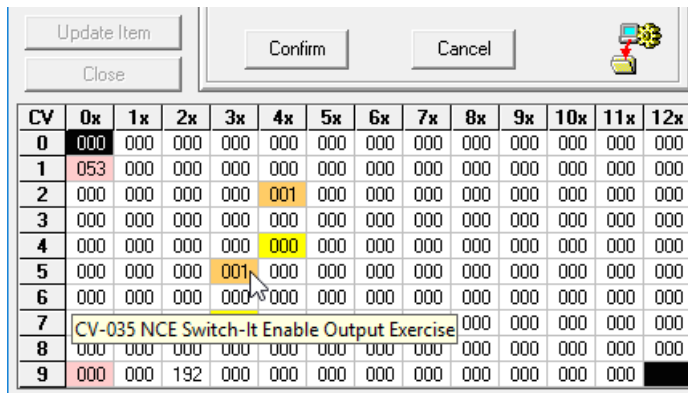

When you are satisfied, click **Confirm** to proceed, where progress will be indicated with the normal **red** and **light green** highlighting –

The screenshot shows a software window with a table of CV values. The table has columns labeled CV, 0x, 1x, 2x, 3x, 4x, 5x, 6x, 7x, 8x, 9x, 10x, 11x, and 12x. The rows are numbered 0 to 9. Callout boxes point to specific cells:

- Orange highlight - changed and selected CV:** Points to the cell at row 1, column 0x (value 053).
- Yellow highlight - selected CV:** Points to the cell at row 2, column 4x (value 001).
- Green highlight - programmed CV:** Points to the cell at row 5, column 3x (value 001).
- Red highlight - CV programming in progress:** Points to the cell at row 9, column 0x (value 000).

Buttons at the top include 'Update Item', 'Close', 'Confirm', and 'Cancel'. An hourglass icon is also present.

Completion of programming is signalled by the normal 'success' message –

The screenshot shows the same software window as before, but with a green checkmark icon and the text 'Programming Completed Successfully' displayed prominently. The 'Finish' button is now visible. The table below shows the same data as in the previous screenshot, with the 0x column for row 9 now highlighted in red.

Click the **Finish** button to return to the **Addr**s Parameter Tab.

Note that when programming an Accessory's address or parameters there is no feedback from the Mainline Track to positively confirm whether the operation has been successful or not. The only way to verify the outcome is to operate the Accessory using a Handheld Cab, or via the A-Track **Operate** facility described in the following **Section 7.4**.

If you use NCE Snap-It, QSnap-Mk2, or Switch-Kat accessory decoders, there are some additional timing parameters which can be programmed, if you require different settings from the default values loaded into the stock items by the manufacturer.

The **NCE Timing** parameters are displayed next to the other NCE Options on the Addr's Parameter Tab, where you can enter the value, or values, you require in the relevant textbox (having, of course, checked the decoder documentation for the allowable range of values) –

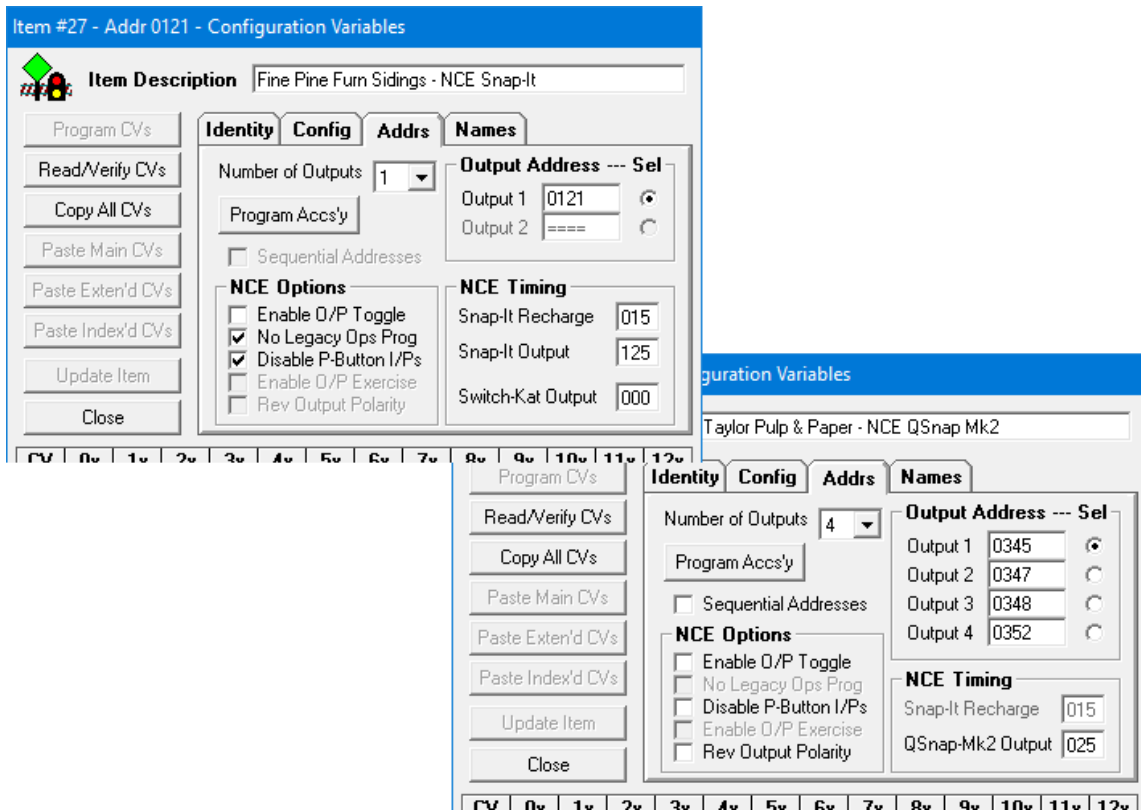

After you click **Program Accs'y**, and have answered **OK** to the normal request to configure the decoder for programming, when you click on the **NCE Options** button on the Program CVs page, a further message will be displayed, depending on the decoder type –

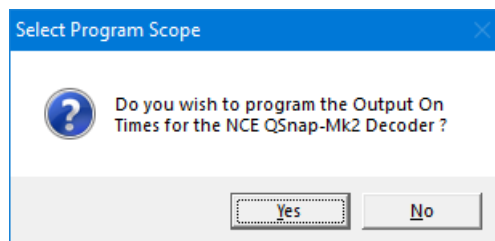
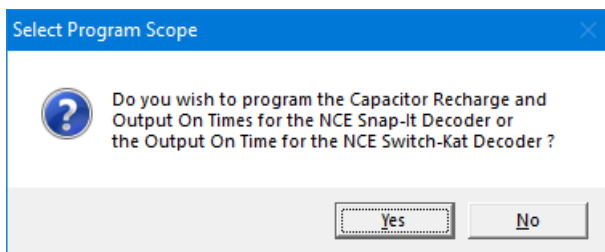

Clicking **Yes** will select the relevant **NCE Timing** CVs in the CV Grid in addition to the other NCE Options CVs by highlighting them in **yellow** (or **orange**), whereas clicking **No** will leave the selection at the NCE Options only –

Update Item | Close | Confirm | Cancel

CV	0x	1x	2x	3x	4x	5x	6x	7x	8x	9x	10x	11x	12x
0	000	000	000	000	125	000	000	000	000	000	000	000	000
1	031	000	000	000	000	000	000	000	000	000	000	000	000
2	000	000	000	000	001	000	000	000	000	000	000	000	000
3	000	000	000	000	000	000	000	000	000	000	000	000	000
4	000	000	000	000	001	000	000	000	000	000	000	000	000
5	000	000	000	000	000	000	000	000	000	000	000	000	000
6	000	000	000	000	000	000	000	000	000	000	000	000	000
7	000	000	000	000	000	000	000	000	000	000	000	000	000
8	000	000	000	015	000	000	000	000	000	000	000	000	000
9	000	000	192	000	000	000	000	000	000	000	000	000	000

Highlighted NCE Timing CVs for Snap-It (38 + 40) & Switch-Kat (03)

Update Item | Close | Confirm | Cancel

CV	0x	1x	2x	3x	4x	5x	6x	7x	8x	9x	10x	11x	12x
0	000	000	000	000	000	000	000	000	000	000	000	000	000
1	023	000	000	000	000	000	000	000	000	000	000	000	000
2	000	000	000	000	000	000	000	000	000	000	000	000	000
3	000	000	000	000	000	000	000	000	000	000	000	000	000
4	000	000	000	000	000	000	000	000	000	000	000	000	000
5	000	000	000	000	000	000	025	000	000	000	000	000	000
6	000	000	000	000	000	000	025	000	000	000	000	000	000
7	000	000	000	000	000	000	025	000	000	000	000	000	000
8	000	000	000	000	000	000	025	000	000	000	000	000	000
9	001	000	192	000	000	000	000	000	000	000	000	000	000

Highlighted NCE Timing CVs for QSnap-Mk2 (65 - 68)

Again, if you do not want to program all of the selected NCE Timing or Options parameters at this time, you can remove the **yellow** or **orange** highlight from those you want to leave unprogrammed, by holding down either **Ctrl** (Control) key on your keyboard and then clicking on the relevant cell in the CV Grid.

Programming values which do not apply to this particular type of accessory decoder will not cause a problem, since the programming commands will simply be ignored by the decoder.

When you are happy with the selection, click **Confirm** to proceed with programming as described previously.

In all cases, when you have finished programming any type of accessory decoder, *do not forget to restore the decoder to an operational state, resetting switches, or removing any programming links or temporary wiring, where necessary.*

7.4 Controlling Accessory Decoders

As mentioned in the previous **Section 7.3**, the only real way to verify that an accessory decoder has been programmed successfully, is to operate the Accessory. While you can do this easily using a Handheld Cab, A-Track also provides an **Operate** facility which allows you to exercise all of a decoder's outputs from the computer screen.

From the Item List, if you right-click on an Accessory Item, the **Operate** option on the **PopUp** menu (also available from the **Item** menu) allows control of the state of individual Accessory Outputs –

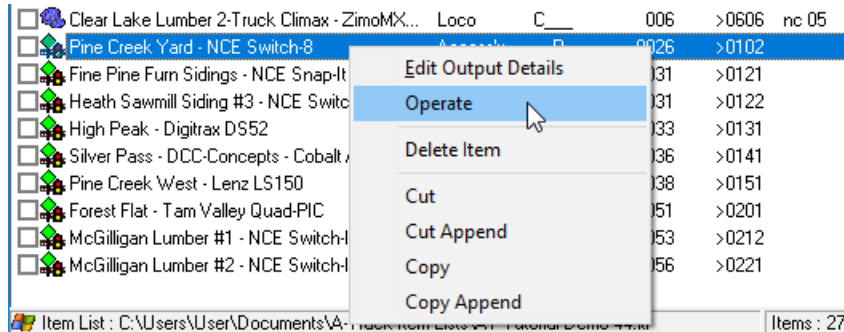

Clicking **Operate** opens a new window on the screen in the form of a 'soft controller', similar to that described in **Section 6.9** for Locomotive Items, which, by use of the mouse to click the relevant buttons, lets you issue commands to switch the state of the Accessory Outputs, together with some additional functions –

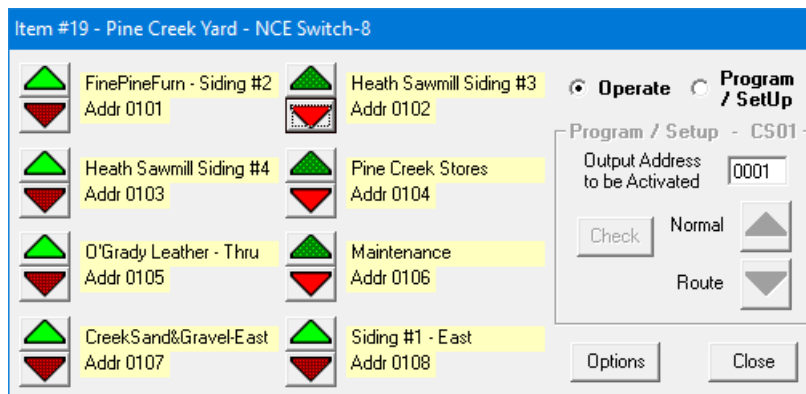

The example above shows, on the lefthand side, the controls for an NCE Switch-8 accessory decoder with eight Outputs, opened as Controller **CS01**. Each Output shows the description and address (0101 through 0108 in this case) assigned to that Output in the corresponding Item definition, plus two buttons to switch the state of the Output.

As discussed previously, in the introduction to Accessories in **Section 7.1**, it is assumed that accessory decoders will be applied to operate turnouts, so the **green** button (▲ or ▲) will set the turnout to the **Normal** (Straight) position, and the **red** button (▼ or ▼) will set the turnout to the **Route** (Diverging) position.

One button will be in a 'bright' state (▲ or ▼) to indicate the direction of the last command sent to the turnout, while the other button will be set to the 'dark' state (▲ or ▼). Hence, in the example above, Outputs 102, 104, and 106 are set to Route, while Outputs 101, 103, 105, 107, and 108 are in the Normal state.

These commanded states can be seen in the **Function** (rightmost) column of the Item List in Details view, where an Output set to Normal will be shown as '0', and one set to Route will have the Output number displayed –

NCE Switch-8	Access'y	A_P_	0026	>0102	CS 01	02040600
ings - NCE Snap-It	Access'y	_P_	0031	>0121		1_____
ing #3 - NCE Switch-Kat	Access'y	_P_	0031	>0122		0_____
ax DS52	Access'y	_P_	0033	>0131		12_____
Concepts - Cobalt AD4	Access'y	_P_	0036	>0143		0000_____
Lenz LS150	Access'y	_P_	0038	>0151		100050_____
/alley Quad-PIC	Access'y	_P_	0051	>0201		0230_____
#1 - NCE Switch-It	Access'y	_P_	0053	>0212		00_____
#2 - NCE Switch-It Mk2	Access'y	_P_	0056	>0221		00_____

ser\Documents\A-Track Item Lists\AT-Tutorial-Demo-44.itl Items : 27 Current : 19 NCE ▲ COM ▲

Accessory Items which represent decoders with less than eight Outputs will only have status numbers shown for those Outputs which exist, with the other, unused Function columns displaying an underscore (_) symbol, as shown above.

The NCE Power Pro Command Station maintains a record of the last command sent to all turnout addresses from either A-Track or any Handheld Cab. This data is loaded by A-Track from the Command Station (at the same time as Consist data) each time the program is started. All turnout status data is also reloaded each time an Accessory 'soft controller' is opened by clicking **Operate** (not just the data for the turnouts associated with that Item).



Hence, as soon as an Item List is loaded, the Output status relevant to each Accessory Item will be displayed in the Function column of the Details view. If no command has ever been sent to a particular address, then the turnout is assumed, by the NCE Power Pro system, to be in the Route (diverging) position.

However, turnout status data is not available from an NCE Power Cab system so, in this case, the Item List Function column in an Item List will only show status due to commands sent from A-Track, and subsequently saved within the Accessory Items in the Item List.

Note that the status data from either source relates only to the issued turnout commands, and does not necessarily align with the actual turnout position, which, for example, may have been altered manually at some time. Automatic, real-time monitoring of actual turnout positions is beyond the capabilities of all standard Command Stations although, by fitting one or more Auxiliary Input Units (AIUs) to the Cab Bus of either an NCE Power Pro or Power Cab (including Smart Booster and DCC Twin) Command Station, you can allow A-Track to monitor continuously the position of all turnouts connected to an AIU. This is covered fully in **Section 8.4**.

The Output command buttons of the Operate 'soft controller' make no reference to any turnout status data when generating turnout commands. Clicking the **green** button (▲ or ▲) always sends a **Normal** (Straight) command, and a click on the **red**

button ( or ) will always send a **Route** (Diverging) command to the turnout, via the Command Station (Power Cab or Power Pro).

For example, clicking the 'dark' **green** () button of Output 102, sends a Normal (Straight) command to the turnout with address 0102, changes the button picture to , and results in a change of the Accessory status indicator in the Item List from '2' to '0' as shown below –

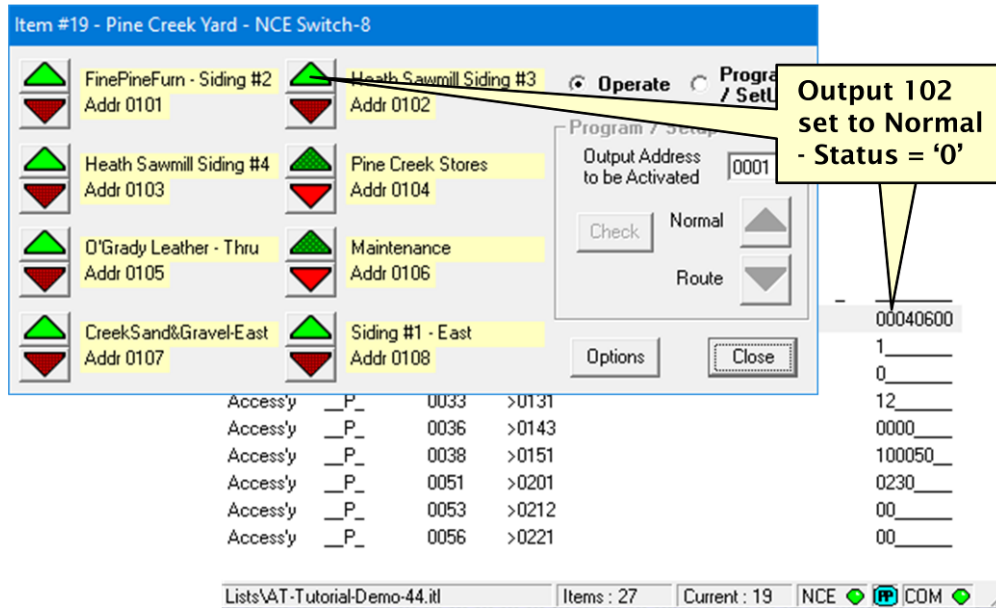

If the Accessory Item has less than eight Outputs, then the Operate 'soft controller' unused controls will be disabled, as shown below for the case of an NCE Switch-It decoder Item –

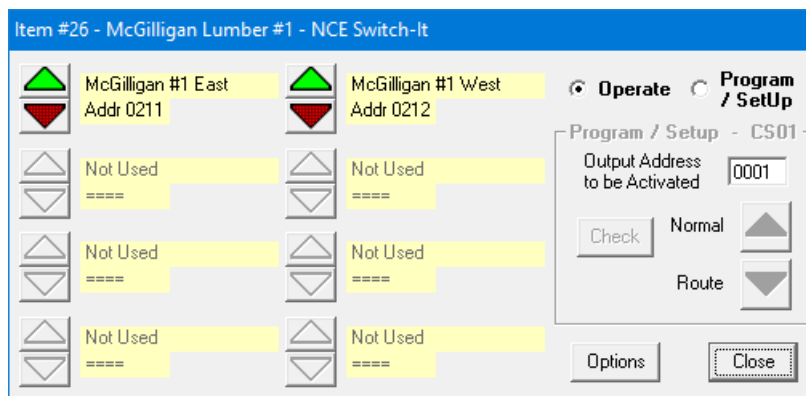

You can choose to edit the description attached to any of the Accessory Outputs, or to enable any which are currently disabled – or *vice versa*. Taking as an example a Lenz LS150 accessory decoder, which has six Outputs, of which four are currently allocated to control actual turnouts –

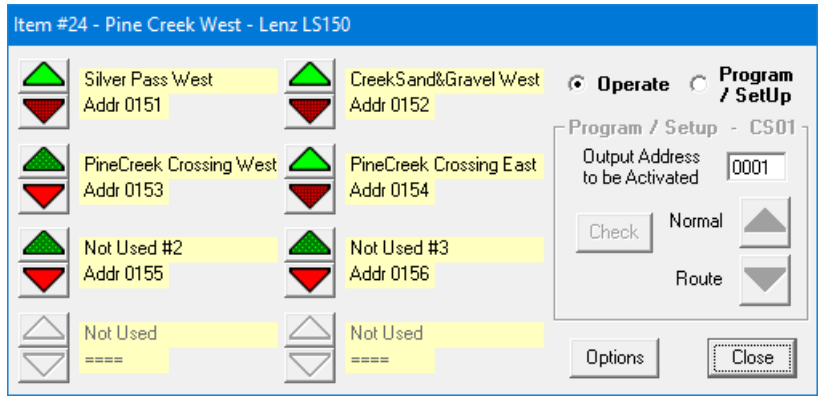

Click on the **Options** button to display the available facilities for customisation –

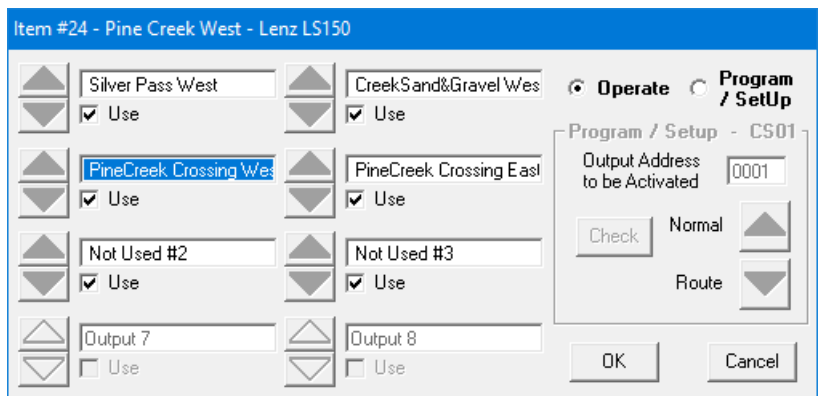

If, in the course of controlling your layout, you feel that some of the Output descriptions could be amended or clarified, you can change the **caption** for each Output from those originally defined in the relevant Accessory Item, as shown, to any description which you will find more meaningful. Just click in the relevant textbox, to highlight the current name (as shown for Output #3 'Pine Creek Crossing West' above), and then type in your own text to modify the caption as required.

In addition, if not all of the Outputs are currently used to operate turnouts on the layout, you can disable the unused Outputs by clicking to remove the tick in the associated **Use** checkbox, as shown below, where the two Outputs not currently in use have been disabled (Outputs 5 and 6), and the descriptions for Outputs 3 and 4 have been edited –

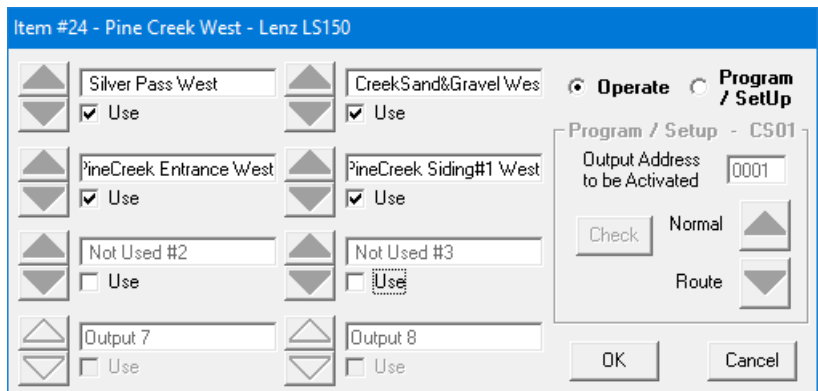

Click **OK** to accept the changes, giving the customised controller shown below, or click **Cancel** to discard all changes and return you to the previous state of the controller.

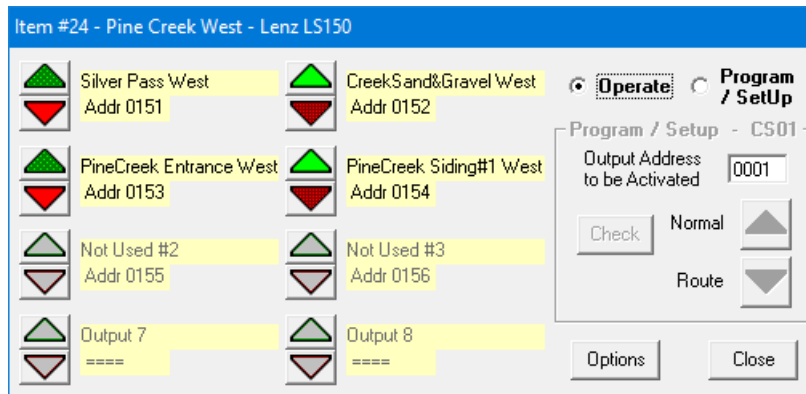

If, at some future time, you decide to make use of the disabled Outputs, simply click the **Options** button again, tick the **Use** textboxes to re-enable the required Outputs, label the Outputs to identify their new usages, and click **OK** to confirm the changes.

When you have finished using the Accessory controller to issue turnout commands, and click the **Close** button to remove it from the screen, if you have used the Options facility at any time to customise the controller, you will be prompted to save your customisation changes –

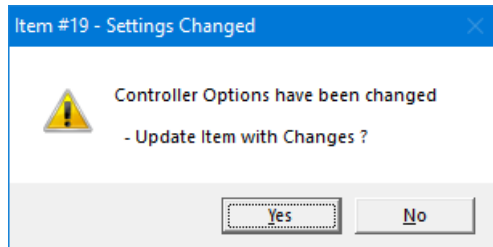

Click **Yes** to update the Accessory Item or **No** to discard the changes and leave the Item as it was. Note, in particular, that if the Output names have been edited, then the changed names will replace those previously held in the Item.

In addition, all changes to turnout status as a result of using this Accessory Item’s controller are recorded automatically within the Item each time a turnout command is issued. A prompt to save these status changes is not raised when you close the Accessory Item controller, but will later result in a prompt to save the complete Item List, either when you close A-Track, or when you load another Item List –

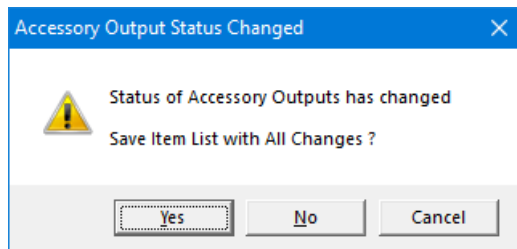

If you are using an NCE Power Pro system, and have made no other changes to any Item, it is not essential to save the Item List at this time, since the turnout status changes are fully recorded in the Command Station. However, you are recommended to do so if you are using an NCE Power Cab (including Smart Booster and DCC Twin) system which does not collect any turnout status data to be reloaded to A-Track. Clicking **Yes** to save the Item List in either case is, of course, the safe option.

The example Accessory Items set up in A-Track so far have each been for a single type of accessory decoder, for convenience in programming, since the set-up for each manufacturer is different. However, once the addresses and any other parameters have been programmed into the decoders, it is possible to simplify operation from the screen by defining a **"super" Accessory Item** which collects a set of several decoders together, with up to a total of eight Outputs, under a single control.

To do this, we firstly create a new Accessory Item in the Item List by using the **Insert Blank Item** option on the **Edit** menu (or clicking the  icon on the Toolbar), and then open the new Item's **Edit Configuration Variables** (Edit CVs) window.

Give the new Item a title, such as 'Forest Flat & McGilligan Lumber', tick the **Program on Main Track (Manuf Specific)** checkbox on the **Config** Parameter Tab, then select 8 as the **Number of Outputs**, and enter the addresses corresponding to three (programmed) Accessory Items already in the Item List into the **Output Address** textboxes on the **Addr** Parameter Tab –

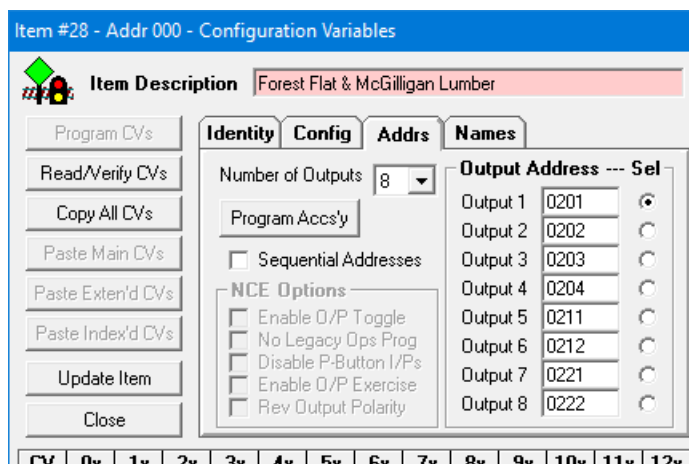

After clicking **Update Item** to save the new "super" Accessory back to the Item List, double-click on the new Item to re-open the Edit CVs window (or right-click to open the PopUp menu, then click on **Edit Output Details**), where you can click on the **Names** Parameter Tab to enter descriptive titles for each of the eight Outputs.

The easiest way to add the relevant Output names is to open Edit CVs windows for each of the Items where they are already defined, and then copy the **Output (Turnout) Name** text from each Output to the corresponding textbox of the new "super" Accessory Item, as in the example below –

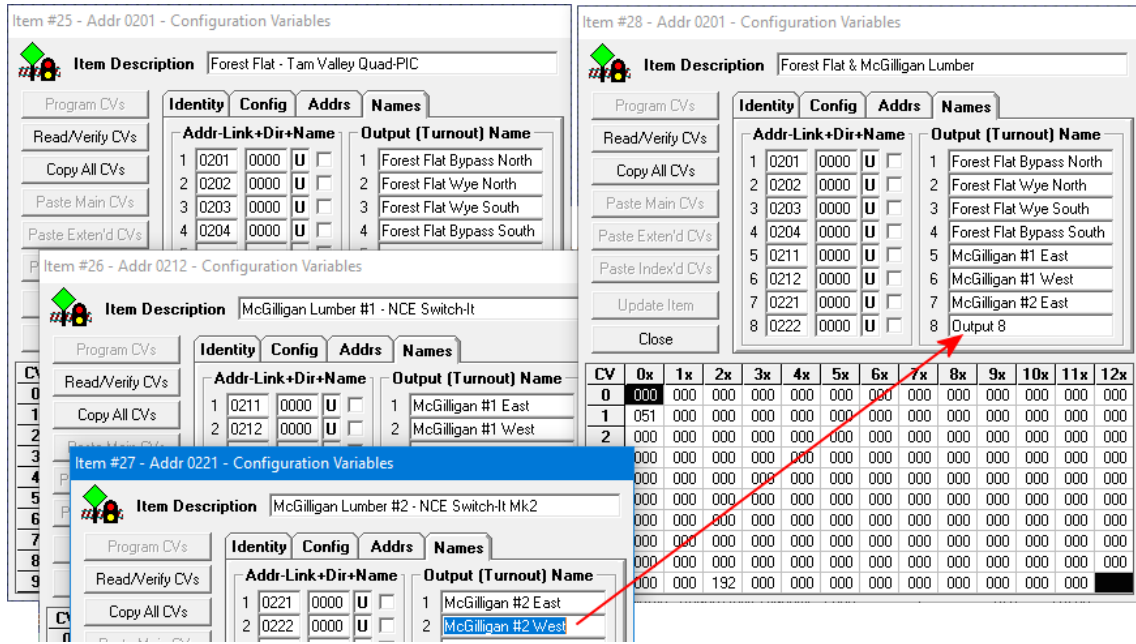

The names for Outputs 1 through 7 have already been copied across from the opened Items #25, #26, and #27 so, to copy the final name for Output 8 in the same way, click in the second **Output (Turnout) Name** textbox of Item #27 to highlight it as shown, press **Ctrl-C** (hold down either Control key, then press the 'C' key) or right-click in the highlighted text and select **Copy** from the pop-up menu. Next, click in the Output 8 **Name** textbox of the "super" Accessory Item (Item #28) to highlight the current 'Output 8' caption, then press **Ctrl-V** (hold down either Control key, then press the 'V' key), or right-click in the highlighted text and select **Paste** from the pop-up menu, to complete the name transfer.

If any of the copied Outputs (Turnouts) have been linked to another Output (Turnout) in this or another Item, then you should also copy details of the relevant Link Address(es) and Direction(s), as described in **Section 7.2**, to the "super" Accessory Item, before clicking **Update Item** to transfer the details back to the Item List.

You can now right-click on the updated "super" Accessory Item to open the PopUp menu and click on **Operate** (or use the **Operate** option from the **Item** menu, or click on the  icon on the Toolbar) to open the normal Operate window -

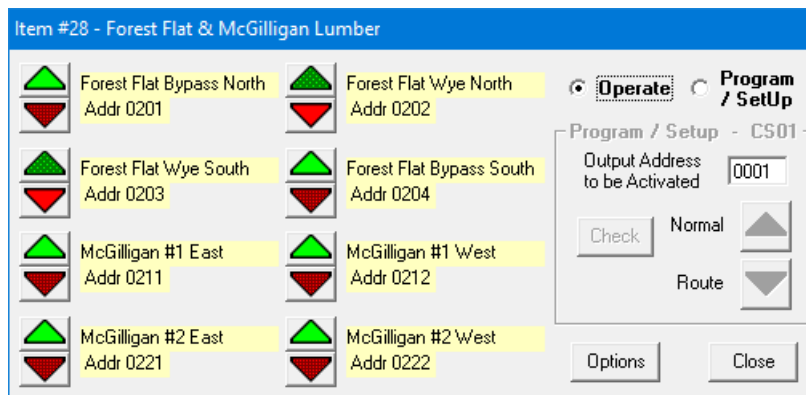

Check that the controls operate their corresponding turnouts correctly, then **Close** the controller and click **Yes**, if prompted, to save any other customisation changes you may have made back to the Item List. Finally, save the complete Item List to preserve all of your new Items and data.

Important Note : After you close A-Track then, the next time you start the program and re-open the saved Item List containing your new "super" Accessory Item, you will see a warning message as shown below –

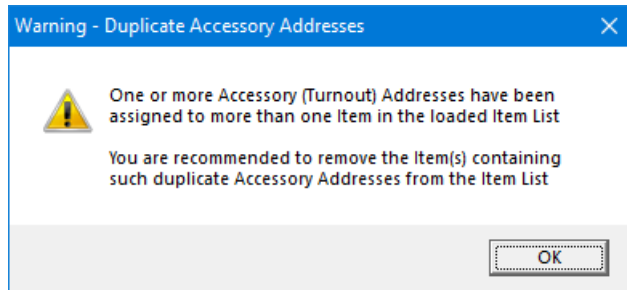

Although the presence of such Items with duplicate Accessory Addresses does not prevent you issuing commands to operate the associated Accessories (Turnouts), it will result in unpredictable operation of the Turnouts when they are operated from Mimic Diagrams, as described in **Sections 8.1** and **8.3**, and when using feedback from the turnouts on the layout (via NCE Auxiliary Input Units – AIUs), as described later in **Section 8.4**, since A-Track cannot determine unambiguously which Item to use as a reference for a particular Accessory Address.

Hence, after defining a "super" Accessory Item and saving the original Item List, you should delete those Items containing the same Accessory Addresses as the "super" Item from the Item List, then save the reduced Item List under a ***different*** filename.

You can then, if you wish, delete the "super" Item from the *original* Item List, so that neither of the two resulting Item Lists contain Items with duplicate Accessory Addresses.

An alternative, and possibly quicker, way to perform this operation is to right-click on the "super" Item and then use the **Cut** option from the pop-up menu to move the Item to the **Copy Buffer** (see **Section 4.5**). Now save the Item List using the original filename (overwrite the file). Click **Paste** from the **Edit** menu to restore the "super" Item to the Item List, then delete all of those Items containing the same Accessory Addresses as the "super" Item from the Item List before saving the revised Item List under a ***different*** filename.

7.5 Programming Accessory Decoders – Control Window

As well as operating turnouts, the Accessory Operate window ('soft controller') can also be used to program accessory decoders. For most modern accessory decoders, the basic action of programming the Address of a decoder Output is accomplished simply by issuing an 'operate turnout' command, using the assigned address of the Output, when the decoder is configured in the manufacturer-defined programming mode.

Hence, as an alternative to using the Program Accessory button from the Edit CVs window, as described in **Section 7.3**, once you have assigned addresses to the Accessory Item and saved it back to the Item List, you can open the Accessory 'soft controller' via the **Item** (or **Pop-Up**) menu **Operate** option. As an example, we can see how this works with a Lenz LS150 accessory decoder.

Use the LS150 decoder's pushbutton and indicator LED to set the decoder into programming mode, following the manufacturer's instructions. The address of each of the six Outputs is then programmed into the decoder, again following the sequence set out by the manufacturer, by clicking either of the **green** or **red** control buttons (▲ or ▼) next to the appropriate address –

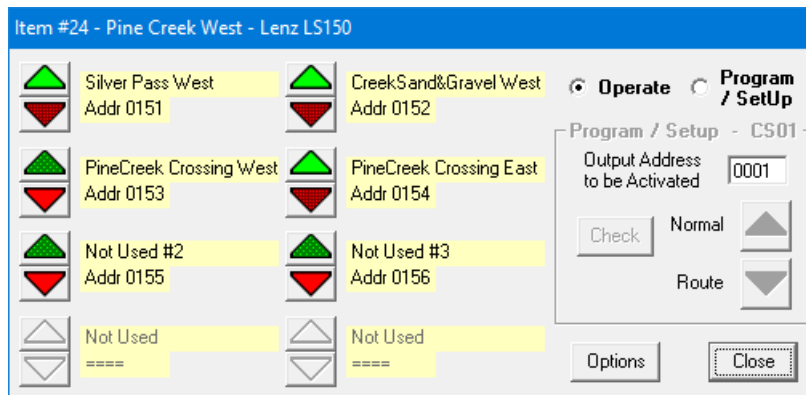

If multiple, separate Output Addresses are to be programmed on the same decoder, then this alternative method can involve fewer keystrokes than by using the Edit CVs window and the normal Program sequence.

Following the transfer of each address, the next step in the LS150 decoder's programming sequence is to set the '**On**' duration of each Output.

In contrast to NCE accessory decoders, where parameters are held in Configuration Variables (see **Section 7.3**), and programmed using the Edit CVs window, the parameters of decoders from other manufacturers, such as Lenz and Digitrax, are generally programmed by issuing control commands to specific addresses. You can do this by using the **Program / Setup** section of the 'soft controller' window, accessed by clicking on the **Program / Setup** option button in the Item's control window, as shown below –

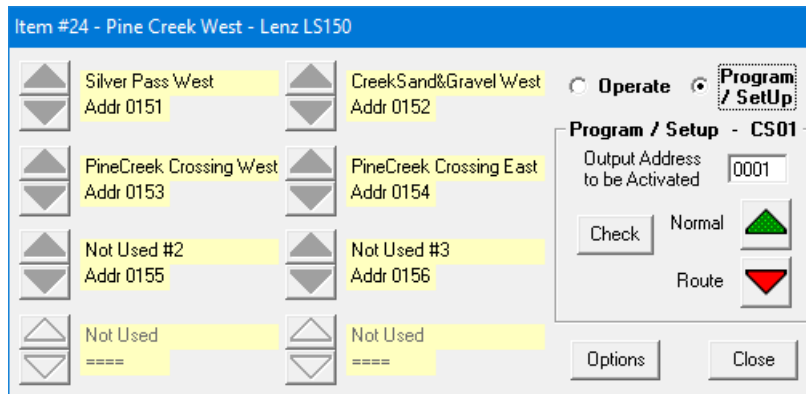

To set the 'On' duration of an LS150 Output, we send a control command to an Accessory address, the value of which represents the required duration. Acceptable values are in the range of 1 to 100, with each unit equating to 0.1 second. So, if we require the Output to be 'On' for 4 seconds when activated, we send a turnout command to Accessory address 0040 by typing this address into the **Output Address** textbox in the **Program / Setup** area, as shown below, and then clicking either the **Normal** or the **Route** control button below the textbox –

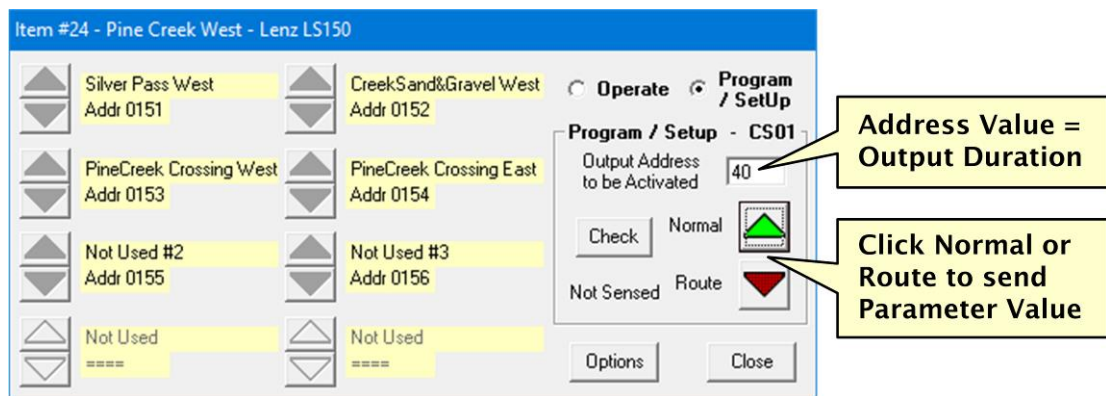

The process is repeated as necessary to set the decoder parameters to the required values.

Note : If we actually have a turnout with address 0040 on the layout, then it will also respond to the Set Parameter command by moving in the appropriate direction, although this will not affect the transfer of the duration value to the LS150 decoder. Hence, it is strongly recommended that you **do not operate** any locomotives on the layout while you are setting up accessory decoders in this way.

The same method using the **Program / Setup** area controls can be used to set up the many operational parameters of a Digitrax DS64 accessory decoder, as a further example. In this case, as well as the address value used, the direction of the issued command, ie. whether the Normal or Route button is clicked, is significant as regards how the command will be interpreted by the decoder. Full details can be found in the relevant Digitrax documentation for the DS64.

In addition to issuing programming or setup commands to the decoder directly associated with the Accessory Item 'soft controller', the controls of the **Program / Setup** area can be used to program the address into **any** other suitable decoder on

your layout. Simply enter the required address into the **Output Address** textbox, configure the target decoder for programming in accordance with the manufacturer's instructions, and click either the **Normal** or **Route** control button to program the entered address into the decoder.

You can also check the last-commanded state of any turnout on your layout by entering its address to the **Output Address** textbox, and then clicking the **Check** button.

Either the **Normal** or the **Route** button will then be displayed in its 'bright' state (▲ or ▼) to show the last-commanded state of that turnout, with the other button in its 'dark' state (◀ or ▶).

If you are connected to an NCE Power Pro Command Station, then the turnout status will have been read directly from the Command Station. This facility is not available from Power Cab, Smart Booster, or DCC Twin systems so, in this case, the turnout status will reflect the last command to that turnout issued by A-Track only – although subsequent commands could have been sent directly from an NCE Cab. Clicking **Check** does not issue any turnout command, nor alter the recorded turnout status in either A-Track or a connected NCE Power Pro Command Station.

Note the caption '**Not Sensed**' which appears below the **Check** button. This indicates that the state of the addressed turnout has not been determined directly from the layout, but has only been inferred from the last known command which was sent to that turnout. However, if you have one or more NCE Auxiliary Input Units (AIUs) connected to the Command Station, and which have been set up to monitor the state of a set of turnouts (see **Section 8.4** for details), then A-Track will be able to report accurately the direction in which any of these turnouts are currently set – irrespective of any issued commands.

In this case, the sensed state of the addressed turnout will appear below the **Check** button, as '**Sensed**', with the direction shown as either Normal (▲) or Route (▼), as shown below –

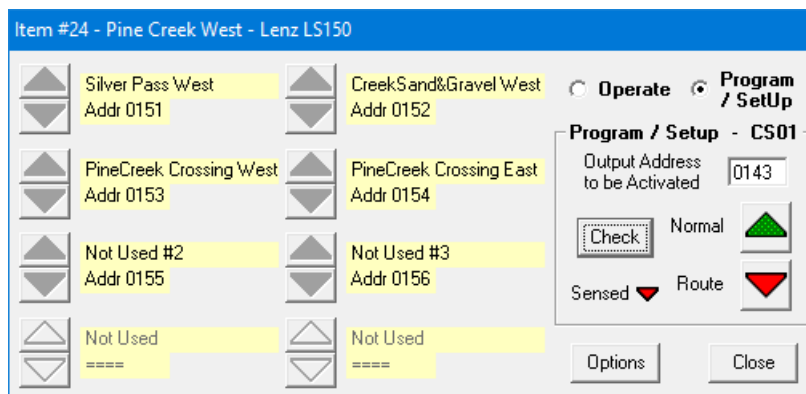

The direction of the last command sent to the addressed turnout is still indicated by the 'bright' state of either the **Normal** or **Route** button. Note, however, that it can take several seconds for the actual turnout state to be sensed after a command has been sent, since any attached AIUs are only scanned one at a time at 2-second intervals (see **Section 8.4**).

7.6 Using Macros to Control Accessories and Set Routes

A **Macro** is a predefined command which, when sent to the Mainline track via the Command Station (a process called 'running' or 'executing' the macro), allows each of a selected group of turnouts to be set to a specified position in a single operation, instead of you having to send individual commands to each turnout. This assumes, of course, that each turnout is driven from an Output of an accessory decoder, with an assigned address so that it can respond to DCC commands.

Each Macro consists of a list or set of Accessory (turnout) commands which, when using a standard NCE system without the assistance of A-Track, are defined using an NCE Handheld Cab, and stored within an NCE Command Station. Refer to the NCE Power Cab or Power Pro System Reference Manuals for further information.

The NCE Power Cab, Smart Booster, or DCC Twin systems allow you to define and store up to 16 Macros, each consisting of up to 8 turnout commands, whereas the NCE Power Pro system provides for the storage of up to 256 defined Macros, each consisting of up to 10 turnout commands.

If you need to operate a group of more than 8 or 10 turnouts in a single operation (in a large, complex switching yard, for example) then you can link or 'chain' two or more Macros together, by using the last entry in one Macro as a pointer to the next Macro to be executed.

The end result of setting a group of turnouts to defined positions, through the use of one or more Macros, is generally referred to as a **Route**.

When used with an NCE Power Pro system, A-Track allows you to download, view, and edit the composition of all defined Macros, to delete Macros or create new ones as required, and then to restore the edited set of Macros to the Command Station (see **Section 7.8**). The Macros are retained by the Power Pro Command Station for as long as its internal back-up battery is functional. You can also save a backup copy of the stored Macros to your computer's hard disk or removable storage, and restore any saved set of Macros to the Command Station (see **Section 9.1**).

While the NCE Power Cab Version 1.65 systems (including Smart Booster and DCC Twin), via the NCE USB Interface unit, give you access to its limited set of 16 stored Macros (see **Section 7.8**), you should be aware that any Macros which are transferred to the Command Station from A-Track **will not be retained** within the Command Station's memory after it is switched off. Such transferred Macros will, therefore, be lost whenever power to the Power Cab system is removed.

Because of this deficiency in Version 1.65 Power Cab, Smart Booster, and DCC Twin systems, A-Track incorporates a facility, as described later in **Section 9.1**, to save the complete status of such a Command Station as a backup file on your computer's hard disk, and to restore this status, including Macro definitions, automatically when A-Track and the associated Command Station are next switched on.

Without automatic restore enabled, A-Track will only be able to download from the Command Station whatever Macro definitions have been made previously with the NCE Cab controls – not necessarily those made and transferred earlier using A-Track. Note that you can, if you wish, avoid this complication by choosing to define and edit all Macros only in A-Track, activating them through the NCE Command Station when required, and not making any changes to Macros through the NCE Handheld Cabs.

A-Track provides the facilities to review and edit any saved set of Macros, independently of the Command Station, and also to add a **description** or **label** to identify each of the defined Macros, helping you to remember the turnout switching operations associated with each Macro. After your edits are complete, you can then either save the updated Macros back to disk, or load all or part of the revised set to an NCE Command Station.

However, you can use the A-Track Macro facility as a fully-operational alternative to that provided by your NCE Command Station, with the ability to define, edit, back-up, and run as many as 256 Macros, each consisting of up to 10 turnout commands, just like an NCE Power Pro system. The only disadvantage, in this case, is that you will not be able to execute these Macros from an NCE Handheld Cab, but only from the A-Track screen.

7.7 Defining, Editing and Saving Macros

Independently of the type of NCE Command Station you use, the facility to create, edit and execute a set of Macros to assist in the control of your layout is found on the **Route** menu, where you should click on the first option, **Display Route Macro Table**, as shown below –

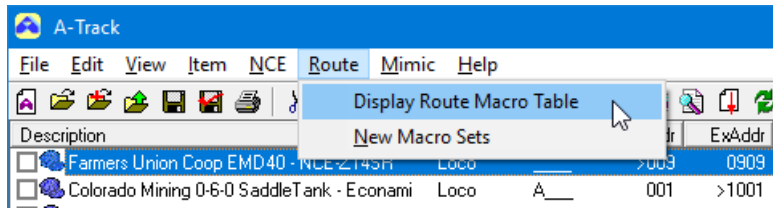

Alternatively, you can click on the  icon on the Toolbar.

If a set of Macros had been loaded since this A-Track session started, then they would be displayed. In this case, however, as the first time the Route Macro Table has been shown, a blank table appears –

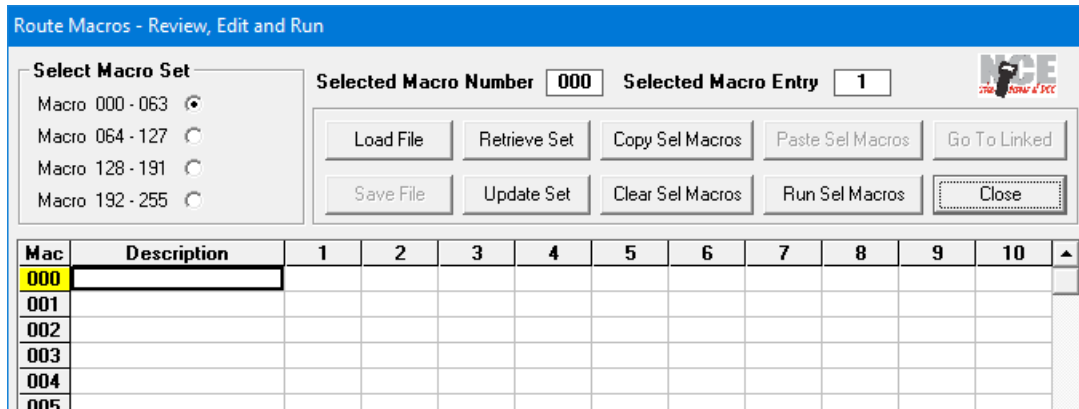

You then have the options of either clicking **Load File**, to open a previously-saved Macro Backup File, or to create a fresh set of Macros. In this case, assuming that no Macros have yet been defined, we can proceed to generate some example Macros.

For convenience, A-Track handles Macros in **Sets**, each of which contains sixty-four (64) macros. Four Sets, therefore, make up the total of 256 Macros that can be stored

in an NCE Power Pro Command Station (or used directly from A-Track with any type of Command Station).

The first Set of Macros (Macro 000 to Macro 063) is marked as selected in the **Select Macro Set** area of the window, and the contents of the Macros (currently blank) are displayed in the **Macro Grid**, in the lower part of the Macro Edit window, which will currently show the first 24 Macros.

Any Macro in the available Sets can be accessed by using the **mousewheel** or the **scroll bar** at the righthand margin to scroll through the other 232 Macro Grid entries. Holding down either **Shift** (↑) key while using the **mousewheel** will scroll by 16 Macros at a time, or you can use the **PageUp** and **PageDown** keys on the keyboard to go up or down by 24 Macros.

As shown, all Macros are empty, and Macro 000 is shown as the current **selected** Macro by having a **yellow** background to its number. The first entry of the selected Macro is a **Description** field, currently highlighted, ready to receive and store the optional name which you can give the Macro. To the right of this are ten (10) further fields, into each of which you can enter an Accessory (turnout) command. The numbers of the **Selected Macro** and **Selected Macro Entry** are always shown at the top of the Macro Edit window so that you are aware of the current selection even if it is scrolled out of sight.

If you wish to review or edit Macros in any of the other three Macro Sets (Macros 64 to 255), simply click on the appropriate option button in the **Select Macro Set** area, and that Set will be scrolled into view in the Macro Grid. Note that A-Track holds the data for all possible 256 Macros at all times, so that selecting a Set to view does not lose any data you have may entered to Macros in the other (currently non-displayed) Sets.

The easiest way to illustrate how Macros are constructed is to use a practical example such as the control of turnouts in a simple switching yard –

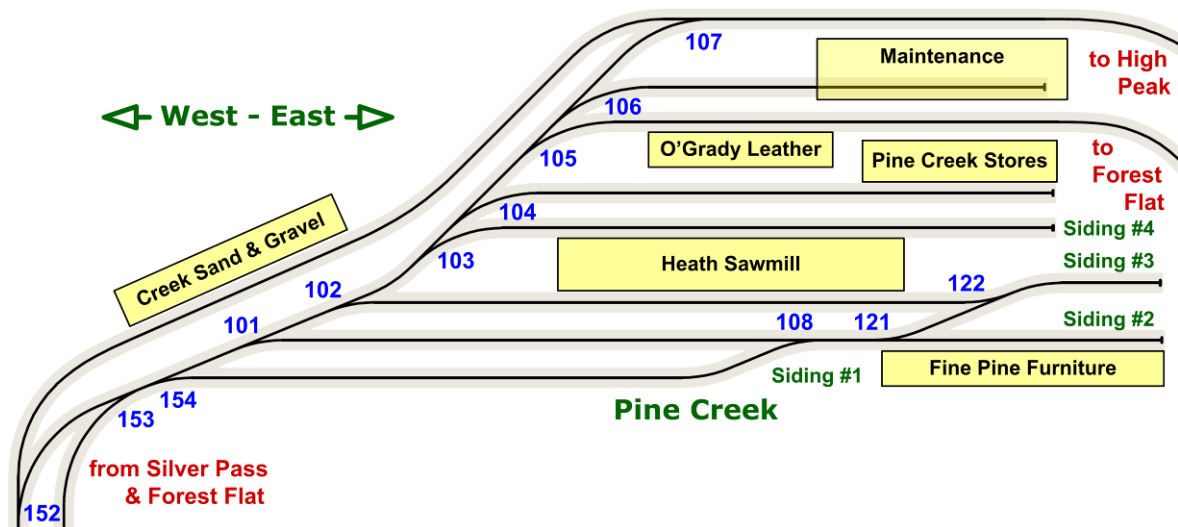

Here we have a set of thirteen turnouts, identified by their allocated Accessory Addresses (0101 through 0108, 0121 and 0122, and 0152 through 0154), controlling access from two mainlines, from Silver Pass and from Forest Flat in the West, to the Pine Creek Yard, where we have a set of sidings, including runaround tracks, with four

commercial enterprises, a maintenance shed, and mainline exits heading off towards High Peak and the other side of Forest Flat to the East.

From the West entrances we can identify routes through the turnouts to each of various destinations and the East exits, and Macros can be defined to specify the turnout setting required to traverse each of these routes.

The first, obvious Macro required is to set the Silver Pass to High Peak mainline as a through route, where we require both turnouts 0152 and 0107 set to the Normal (or Straight) direction. Assuming you have opened the Macro Edit window from the **Route** menu, as described previously, **right-click** in any Macro Grid cell of **Macro 000** (or you can pick any other Macro, if you wish), all of which are currently blank. An **edit window** will appear next to Macro Entry 1 –

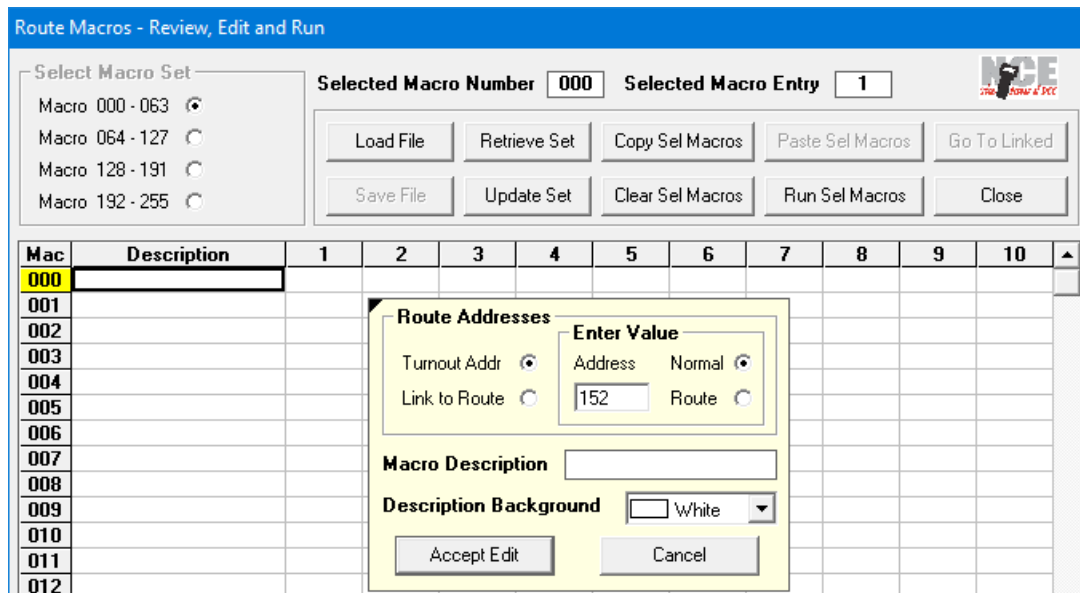

Note the small black triangle (▾) in the top left corner of the edit window. This points to the Entry cell which is being edited, and a similar marker will appear in whichever corner of the edit window is nearest to the relevant cell.

Type the address of turnout 0152 into the **Enter Value / Address** textbox, as shown above, and note that the direction is already selected as **Normal**. Next, click in the **Macro Description** textbox, and enter a description for this Macro. This step is entirely optional and only for your own information. The length of the Description is limited to 24 characters (such as 'Main-SilverPass-HighPeak') and any character entered beyond this limit will be ignored and generate a warning –

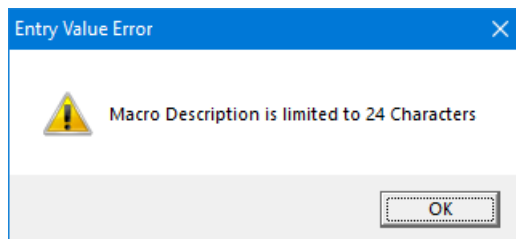

After clicking **OK**, you can either accept the truncated description as it stands, or you can alter the description to fit by, for example, removing spaces or using abbreviations.

Finally, click the **Accept Edit** button, or press the **Enter/Return** key. The first Entry in **Macro 000** will then show **'0152 N'**, with a **light green** background, representing a command which will set the turnout with address 0152 to the Normal direction. Note also that the current Macro Set is now marked as **'Edited'** in the **Select Macro Set** area –

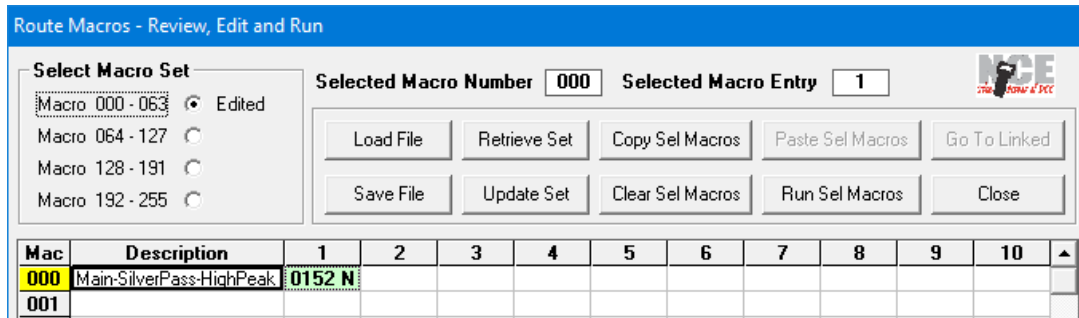

Next, **right-click** in the next Entry (Entry 2) of Macro 000 and type the second turnout address, '107' also set as Normal. Note that the Macro Description entered during the previous edit is displayed in the edit window, and can be further edited if you wish.

It is also possible to place a coloured background behind the Description, again solely for your own information and to help you quickly identify related groups of Macros. To choose a background colour, click the down arrow (▼) at the right of the **Description Background** listbox and click on the desired colour, as shown below (**Green** here) –

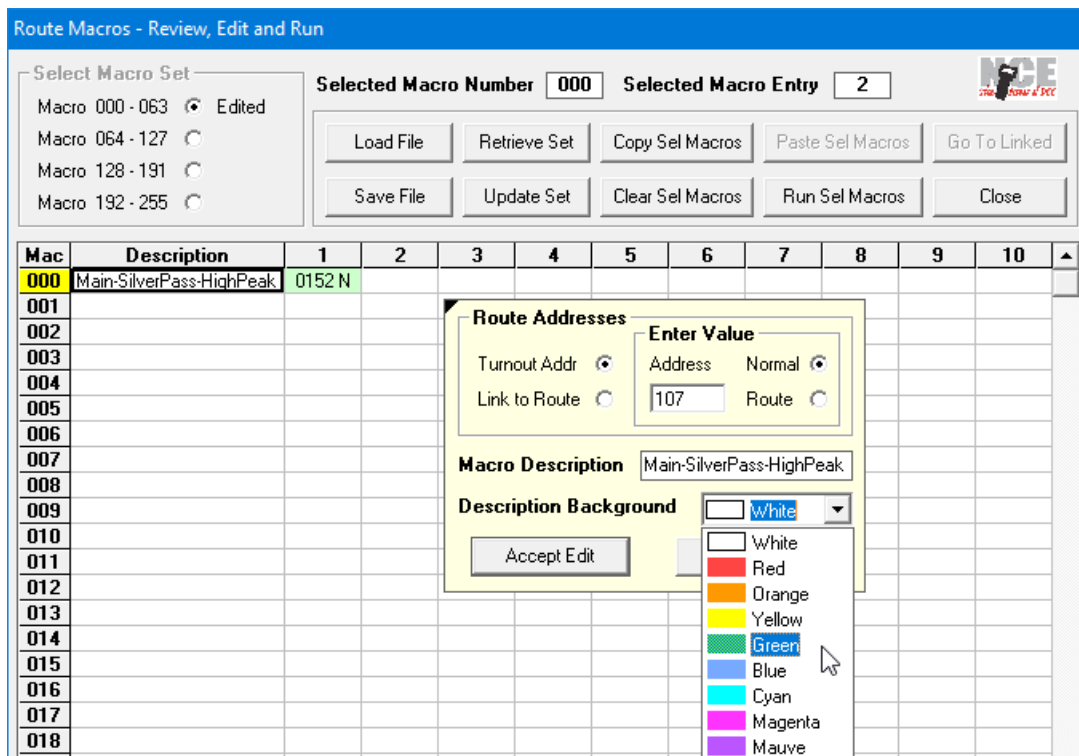

Click **Accept Edit** (or press the **Enter/Return** key) to complete the operation and show the second Macro Entry as **'0107 N'**, with a **light green** background, and to give the Macro Description a **green** background –

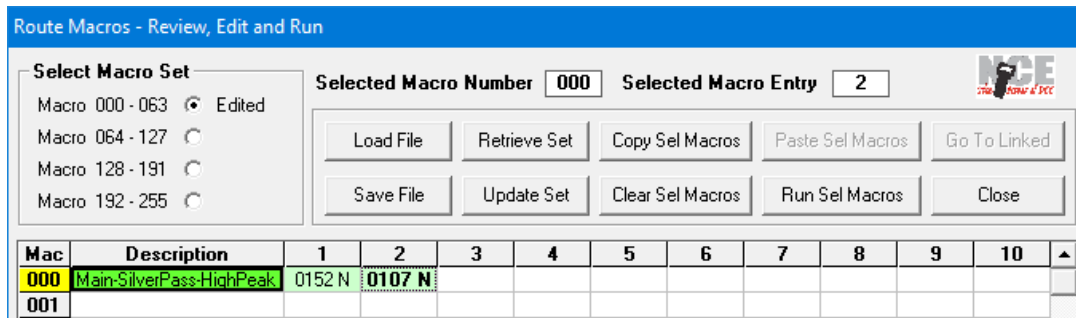

The next Macro we can define is to set the other mainline route, from and to Forest Flat, where turnouts 0153 and 0105 need to be set in the Route (Diverging) direction, and turnouts 0154, 0101, 0102, 0103, and 0104 in the Normal (Straight) direction.

Start as before with a **right-click** in any Macro Entry cell of Macro 001, enter a **Description** and **Background** colour (if required), and then type the first turnout address, '153' in the **Address** textbox –

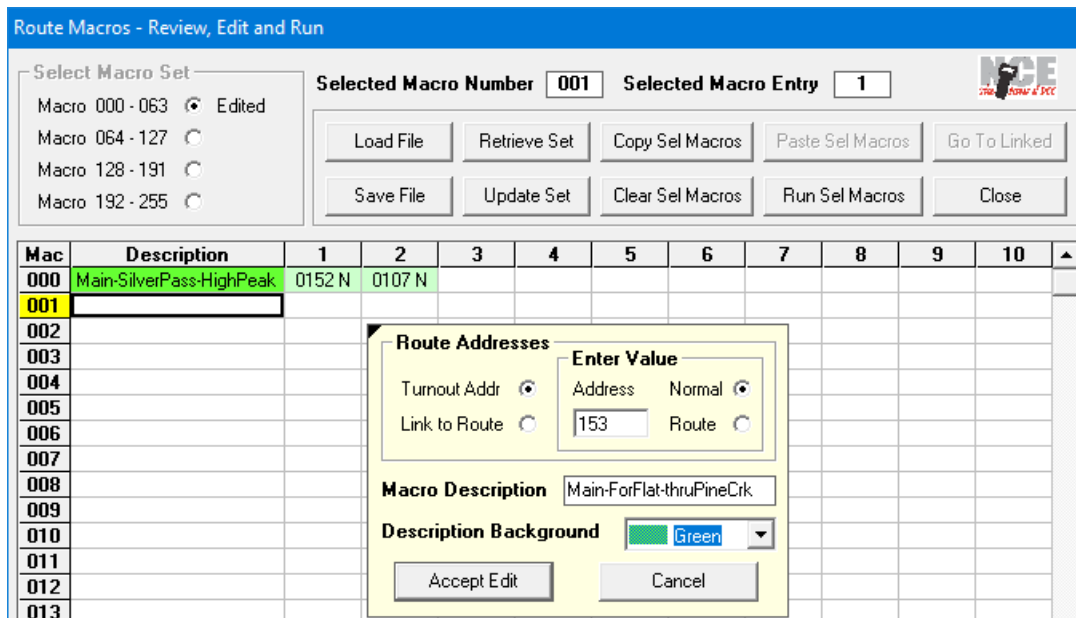

This time, however, we can take a shortcut by typing the letter **'R'** (or **'r'**) immediately after entering the address, instead of clicking the **Accept Edit** button. Entry 1 of Macro 001 will then show **'0153 R'**, with a **pink** background. The edit window will remain visible and will move right to point to the Entry 2 cell. Continue by typing the address of the next turnout ('154') into the **Address** textbox but, this time, press the **'N'** (or **'n'**) key on the keyboard, resulting in Entry 2 showing **'0154 N'** with a **light green** background.

The remaining turnout commands to complete Macro 001 are entered in the same manner, using the **'N'** or **'R'** keys to finish each entry.

Note that, where you have a pair of turnouts, with both turnouts driven from the same Accessory Decoder Output, so that they are linked using the A-Track facility described in **Section 7.2** (with the linked turnout identified with an address equal to the Output Address **plus 3000**) you must enter the **primary** Output Address (plus direction) to throw both turnouts with a single Macro command. If you enter the Linked Address then it will be rejected with an error message –

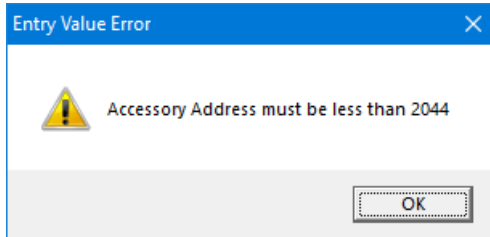

Click **OK** to continue and enter the primary address instead.

Note also that it is not strictly necessary to enter the turnout addresses to the Macro in the same order in which they will be crossed by a locomotive on the track – they can be entered (and thrown) in any sequence that you find convenient.

However, you must not leave any gaps between Entries, since, when the Macro is run, the commands are executed starting at Entry 1 and continuing with each entry in turn until an empty Entry is encountered. Execution of the Macro then stops (and any turnout commands beyond this point are ignored). The final result for Macro 001 will be as shown below –

Route Macros - Review, Edit and Run

Select Macro Set: Macro 000 - 063 Edited
 Macro 064 - 127
 Macro 128 - 191
 Macro 192 - 255

Selected Macro Number Selected Macro Entry

Buttons: Load File, Retrieve Set, Copy Sel Macros, Paste Sel Macros, Go To Linked, Save File, Update Set, Clear Sel Macros, Run Sel Macros, Close

Mac	Description	1	2	3	4	5	6	7	8	9	10
000	Main-SilverPass-HighPeak	0152 N	0107 N								
001	Main-ForFlat-thruPineCrk	0153 R	0154 N	0101 N	0102 N	0103 N	0104 N	0105 R			
002											
003											
004											
005											
006											
007											
008											
009											
010											
011											
012											
013											

Route Addresses dialog box:

Turnout Addr: Address Normal
 Link to Route: Address: Route:

Macro Description: Main-ForFlat-thruPineCrk
 Description Background: Green

Buttons: Accept Edit, Cancel

Click **Cancel** (or **Accept Edit**), or press the **Esc** key on the keyboard, to close the edit window and remove it from the screen. Note that the **yellow** highlight in the leftmost column of the Macro Grid has moved to Macro 001, to indicate that this is the currently selected Macro.

Repeating the definition steps, for the appropriate turnouts, we can then construct Macro 002 to set the route to Fine Pine Furniture Siding #2 from Forest Flat West, giving the Macro Description a **yellow** background this time –

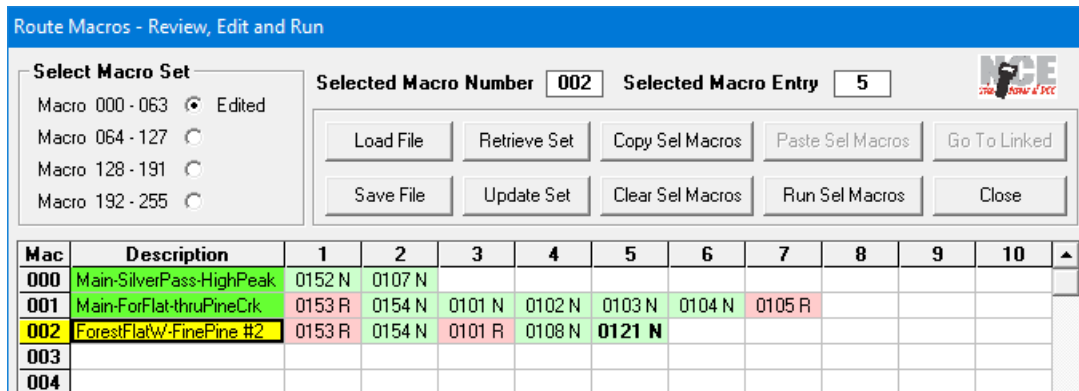

While we could continue in this manner to define Macros for all of the Yard routes, repeatedly typing in all of the turnout addresses can get a little tedious. Hence, to reduce this effort, A-Track incorporates a facility allowing you to 'copy and paste' Macro data.

With Macro 002 still highlighted, click the **Copy Sel Macros** button in the upper part of the window, to copy Macro 002 to an internal storage buffer. Now click in any Entry of Macro 003 (or on **003** in the **Mac** column) to highlight Macro 003, then click on the now-enabled **Paste Sel Macros** button in the upper part of the window to load a copy of Macro 002, including its Description, into Macro 003 –

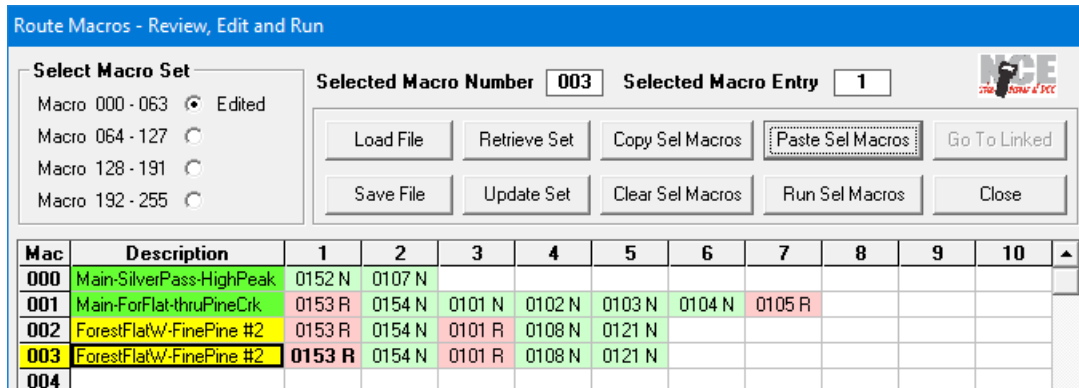

We can now edit this copy to generate a Macro to connect to Fine Pine Furniture from Forest Flat West via Siding #1.

Right-click on Entry 2 of Macro 003 to open the edit window and display the current Macro / Entry details, edit the **Description** as required, then click in the **Address** textbox to the right of the displayed address '154' and simply type 'R' to change the current turnout command entry from '0154 N' to '0154 R'. When the edit is accepted, and the edit window moves right to Entry 3, type '0108R' to continue the update (note the use of the leading zero '0' to ensure that the current command '0101 R' is completely cleared) –

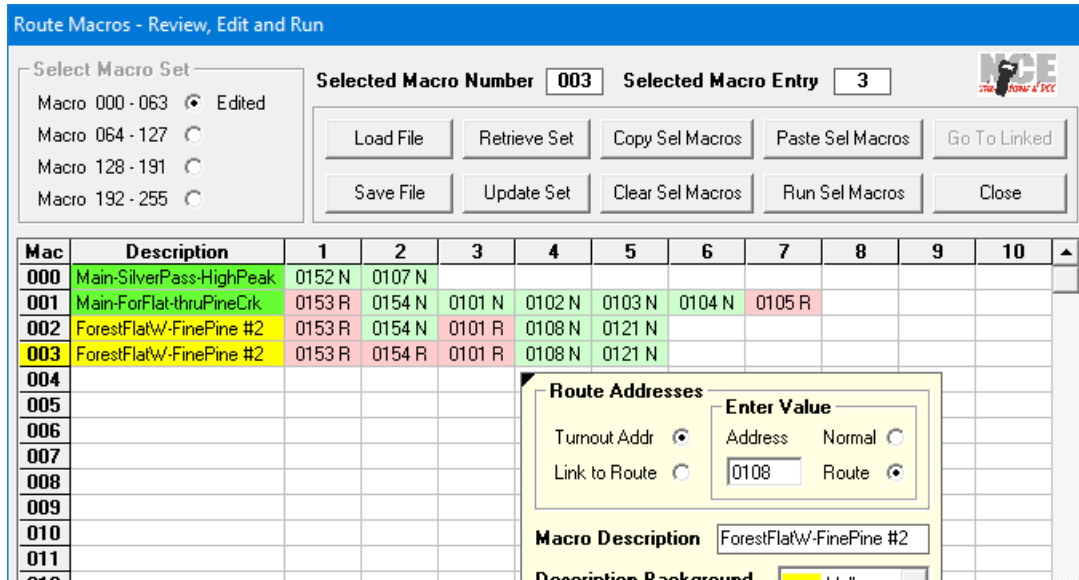

This action will move the edit window on to Entry 4, where typing '0121N' will enter the final turnout command required for the Macro, and leave the edit window at Entry 5, where the remaining (and redundant) command from the copy ('0121 N') can be removed simply by typing '0000' into the Address textbox and then clicking the **Accept Edit** button (or pressing the **Enter/Return** key on the keyboard) –

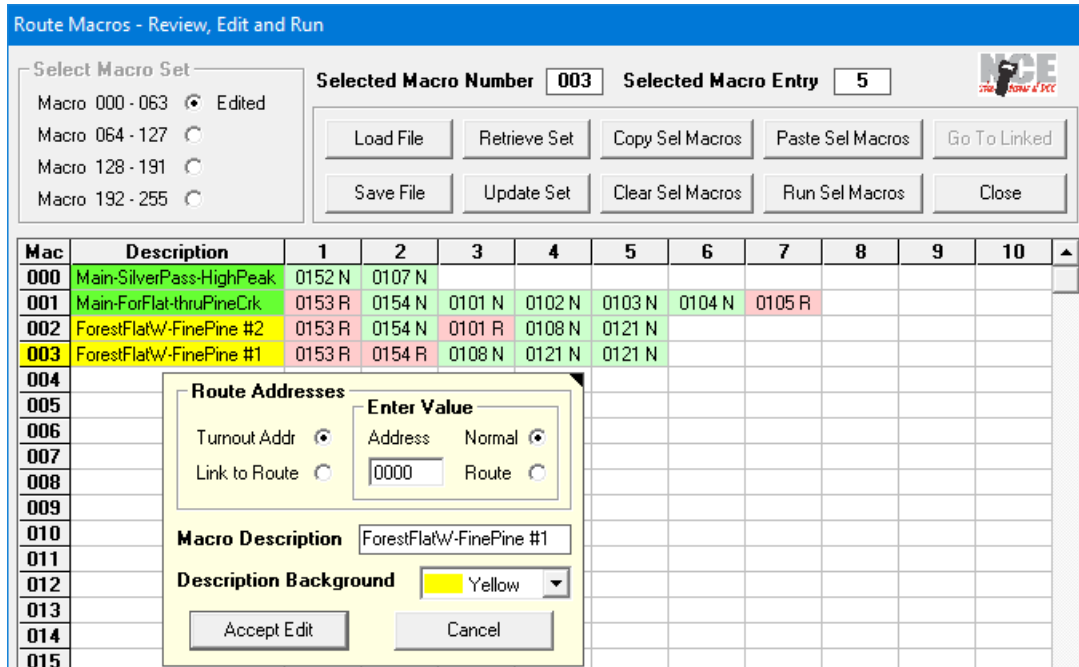

If you make a mistake in editing a Macro, you can delete all entries from the selected Macro by clicking the **Clear Sel Macros** button in the upper part of the window, and then, perhaps, re-pasting your copied Macro as a new starting point.

The 'Copy, Paste, and Edit' process can now be repeated as often as required to define an initial group of Macros, representing most of the routes to the Pine Creek industries and the various though-routes –

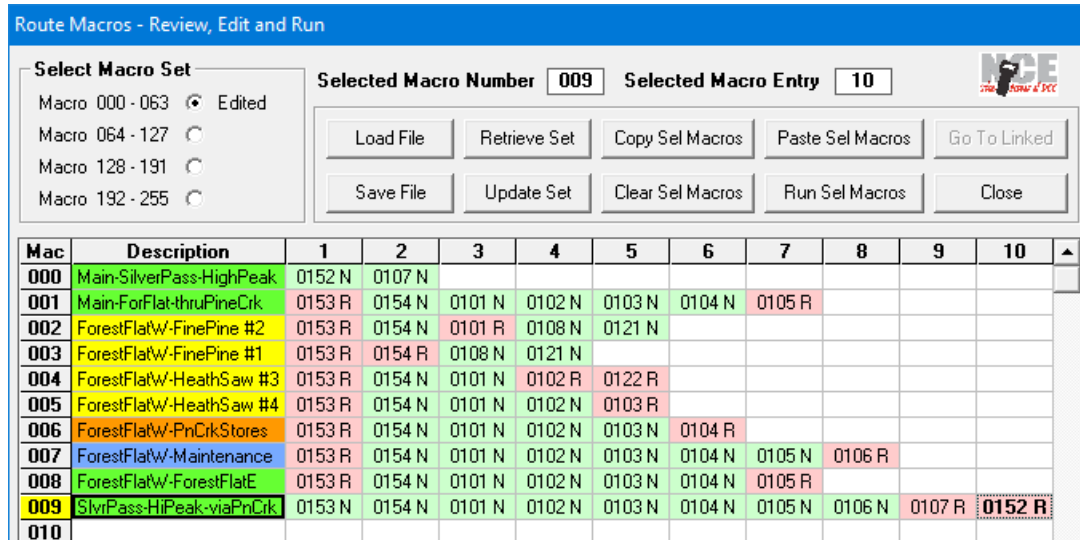

Note, in particular, Macro 009 which has been constructed by making a minor change to a copy of Macro 007 and then adding commands **'0107 R'** and **'0152 R'**. Adding the command **'0152 R'** at the end of the Macro underlines the fact that turnout commands do not need to be entered to the Macro in the same order that the turnouts are physically connected on the layout.

Once you have your initial group of Macros defined, you should save them to your computer's hard disk, or other permanent storage, to safeguard the effort you have put into their creation.

For convenience, Macros are stored by A-Track in files containing 64 Macros, rather than following the suggested format of a single large group of 256 Macros given in the NCE Power Pro System Reference Manual. However, if you have saved all of your NCE Power Pro Macros in a single file, using a program such as Hyperterminal or JMRI's Decoder Pro, A-Track will quite happily load all 256 Macros from such a file into the relevant Macro Sets.

Clicking the **Save File** button in the upper part of the window will display a prompt for you to specify which group of 64 Macros you wish to save. You can begin your selected group at any Macro, not just at 000, 064, 128, or 192, by entering the number of the first Macro in the **Starting at Macro Number** textbox -

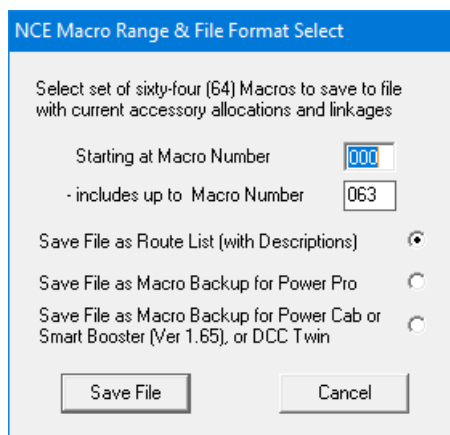

When you enter a starting Macro number, the number of the last Macro to be saved will be updated and displayed for your information.

The Save File prompt also offers three formats for the saved file – a Route List containing all of your entered descriptions and background colours (with file extension **.rbk**), or Macro Backup files without this additional information (with file extension **.mbk**) and which are suitable for uploading to Command Stations.

For the present exercise, just leave the starting value at 000, and the format at Route List, then click **Save File** to display a standard dialog entitled **Save Macro Backup Data** where you can create a specific folder to hold your Macro files. In the example below, this has been created as a subfolder of the standard **Documents** folder, and named **A-Track Route Lists** –

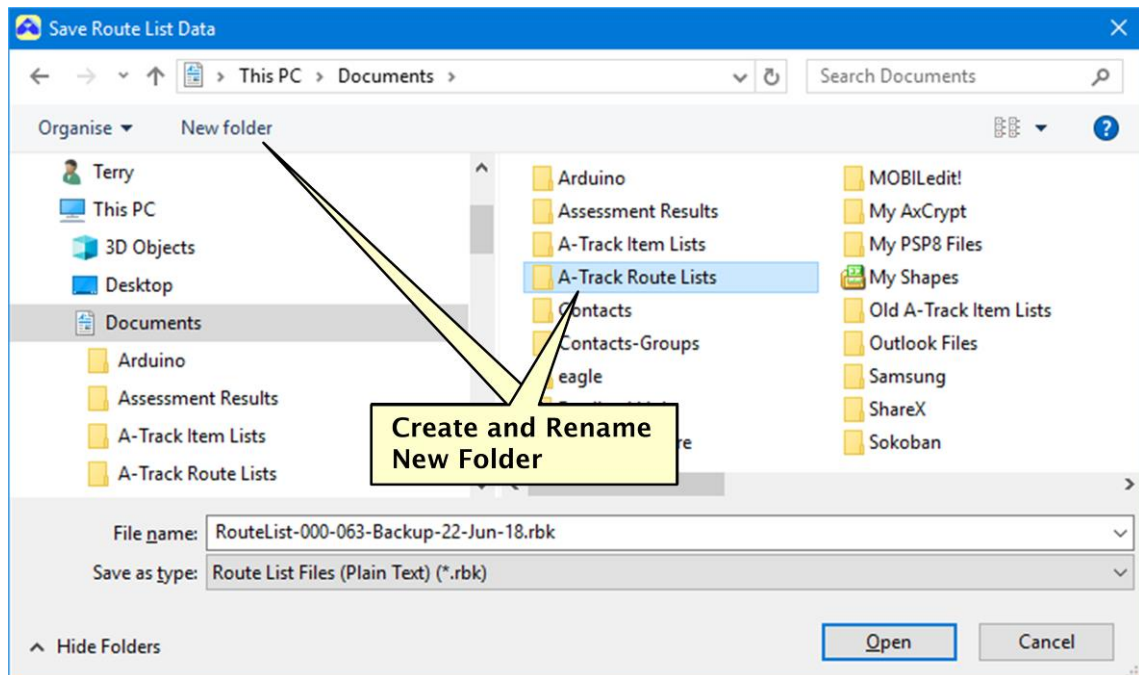

Click **Open** to open the new folder, edit the suggested filename (**RouteList-000-063-Backup-22-Jun-18.rbk**) to your own satisfaction if you prefer a more descriptive alternative, then click the **Save** button to save the Route List file to disk.

Successful completion is confirmed by a final prompt –

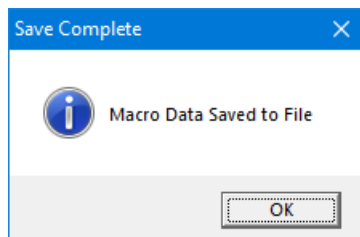

Click **OK** to continue.

Note that the status of the saved Macro Set is now shown as **Saved**, compared to **Edited** whenever any change to any Macro was made –

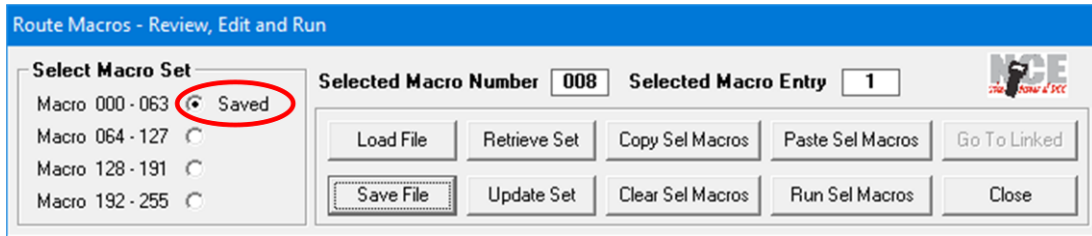

If the Set is subsequently retrieved from file, using the similar **Load Route List / Macro Backup Data** standard dialog –

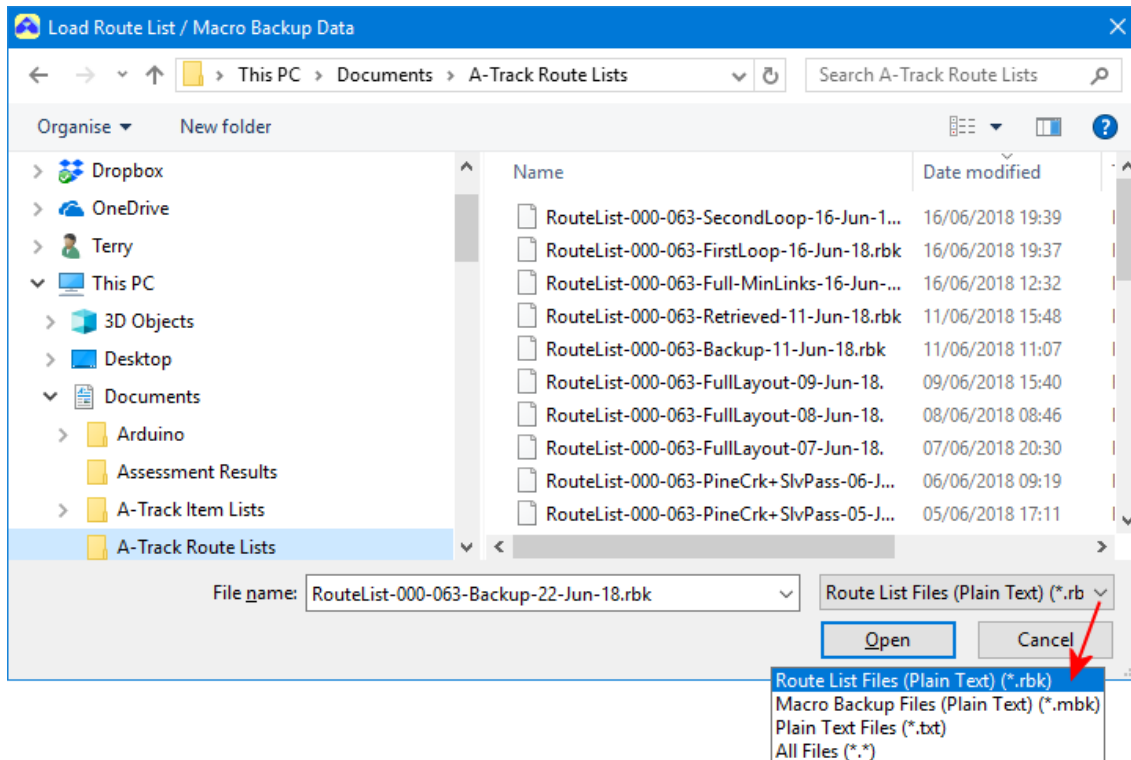

– then the status will change to **Loaded**. Note that, as shown above, you can select the type(s) of file to be displayed, to help you select the appropriate file to load, by using the drop-down menu in the bottom-right corner of the dialog window. Once you click on a file to select it, click on the **Open** button (or simply double-click on the file) to load it to the Route Macro Table.

Note that, if you click the **Close** button in the upper part of the Route Macro Table after creating or editing Macros, the Table will disappear from the screen, but any changes you have made to any of the Macros will be preserved, even if you have not yet saved them to a file. The Route Macro Table can be restored to view again by clicking on the **Display Route Macro Table** option from the Route menu or on the  icon on the Toolbar.

If changes to the Route Macro Table have not been saved to file when you eventually close the whole A-Track program, then you will see a prompt to save (or discard) your changes –

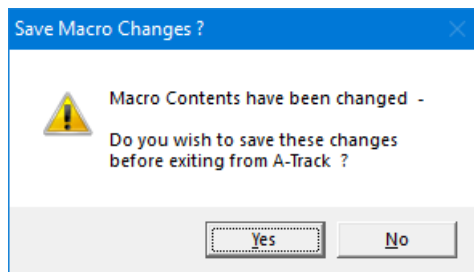

Click **No** to abandon all changes made to the Macros, or **Yes** to return to the Route Macro Table where you can then click **Save File** to preserve your modified Macros.

The structure of the saved Route List (and of other Macro Backup file types) is a plain text file which is compatible with the backup format specified for Macros in the NCE Power Pro System Reference Manual (See **Section 9.1**). The Macro Backup Files contain the Command Station internal memory addresses used to upload defined Macros to the Command Station. The address data is omitted from Route List Files, but they have an additional section to hold the Macro Descriptions and Background Colours.

While you can examine the contents of the saved Route List or Macro Backup files with any text editor (such as Notepad, which comes with all versions of Windows) it is strongly recommended that you do not try to edit them, since it is very easy to corrupt the file structure – which will prevent you reloading it into A-Track. If you really do want to edit the file outside of A-Track, then make a copy of the file first, and edit the copy, just in case.

Although the format of the saved Route List, comprising a set of Accessory Item commands, is not particularly easy to interpret, you can print the loaded Route List, as displayed in the Route Macro Table, either to paper or to an editable file in one of a number of common formats, by clicking the **Print** option on the **File** menu –

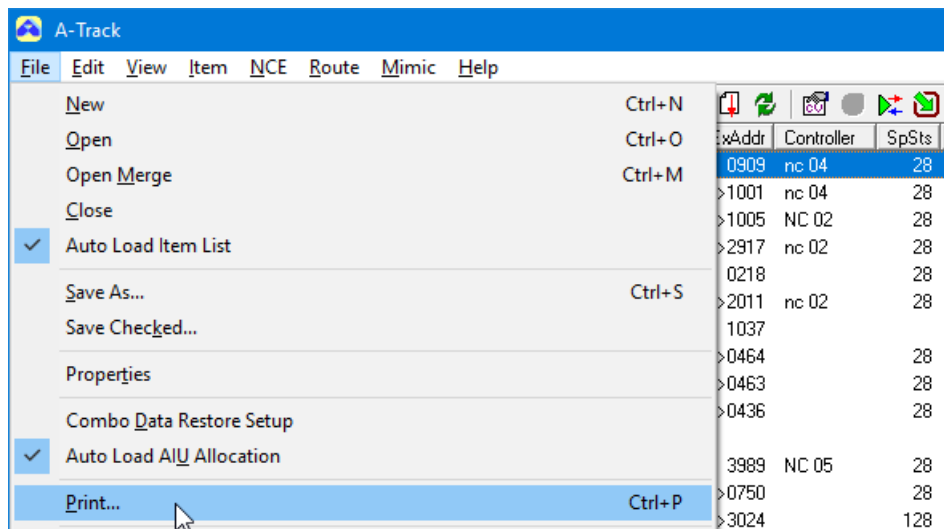

This will open a **Print Items & Lists** window where you can choose to print all, or a selected subset, of the loaded Route Macro Table. If you wish to print the full Route List you do not need to display the Route Macro Table first (although a Route List does have to have been loaded at some time). However, if you want to print just a subset, you will need to display the Table, and then select the required Macros (as described in **Section 7.10**). See **Section 10.6** for full printing details and examples of print-outs.

Once any set of Macros has been saved to a file it can be retrieved simply by clicking the **Load File** button, locating the file in the standard **Load Route List / Macro Backup Data** dialog, and then opening it as described previously.

If any of the currently-loaded Macro Sets have been **edited**, and the contents of the file to be loaded would replace, or overlap, any of these edited Sets, then a warning will be displayed –

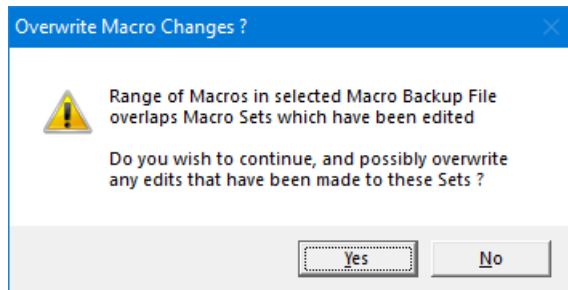

Click **Yes** to overwrite the current Macros, or **No** to abandon the file Load.

Once one or more Macro Backup files have been loaded, the name of the last file loaded can be seen by hovering the mouse cursor over the NCE Logo in the top right corner of the Route Macro window –

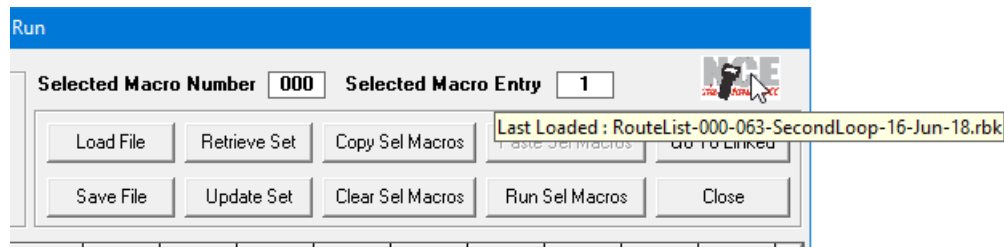

If, at any time, you want to clear the Route Macro Table completely, then you can do so by clicking the **Close** button to remove the Table from the screen, then open the **Route** menu and click on the **New Macro Sets** option –

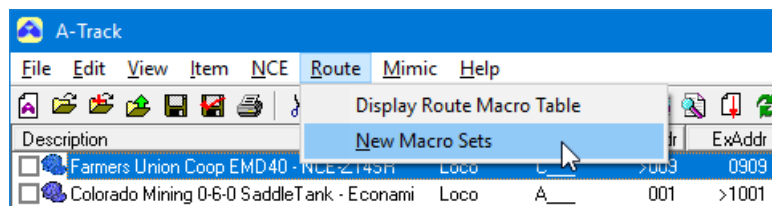

Where the current contents of the Route Macro Table have been changed, but not yet saved, A-Track will display a warning prompt, offering you the opportunity to preserve your edits –

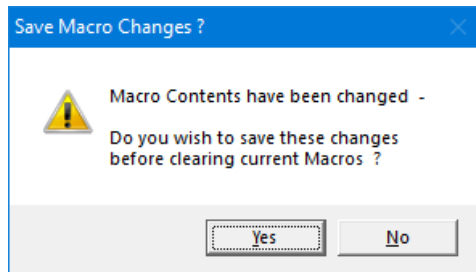



Click **Yes** to open a **Save Macro Backup Data** dialog, and save the Macro Set(s) to an appropriate file, or **No** to clear all Macros and display a blank Route Macro Table.

7.8 Transferring Macros

If you are using an NCE Power Pro or Power Cab Version 1.65 system (including Smart Booster and DCC Twin) then, as well as loading Macros from backup files on the PC, you can also load any stored Macros directly from the Command Station memory into the Route Macro Table. Here they can be edited as required, and then transferred back to the Command Station from which they are directly accessible via any attached NCE Handheld Cab.

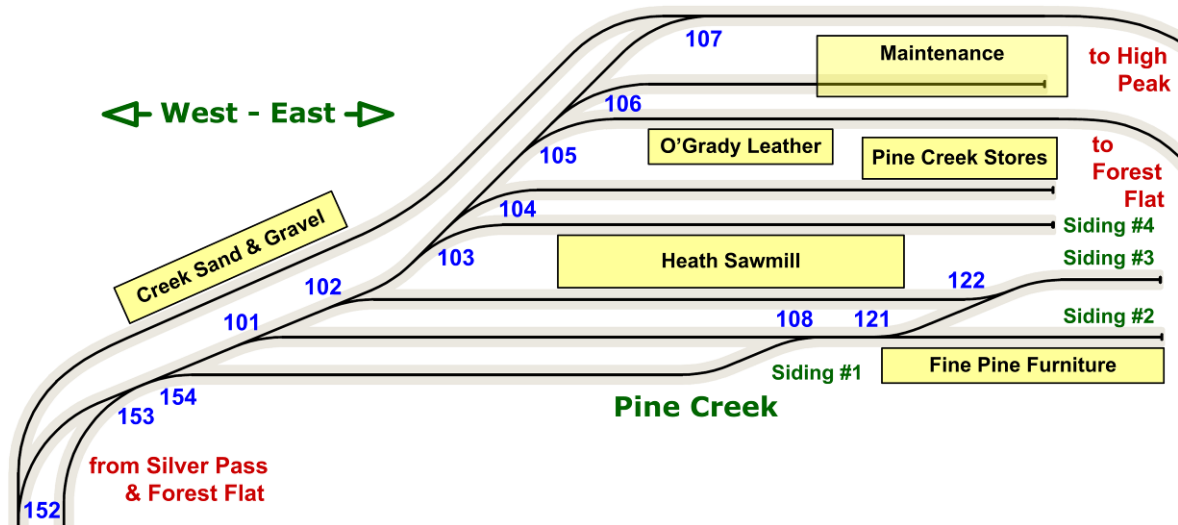
To illustrate the process we can continue to use the Pine Creek switching yard introduced in the previous **Section 7.7** –



Although you can simply open a blank Route Macro Table, into which to import Macros from the Command Station, by going to the **Route** menu, and clicking on the first option, **Display Route Macro Table** (or by clicking on the  icon on the Toolbar) as shown below –

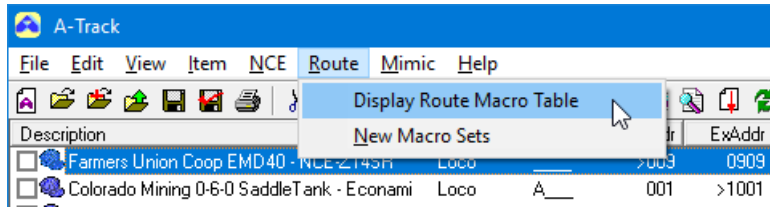

– the available facilities are best shown by assuming that we still have loaded the edited (and saved) set of Macros developed in **Section 7.7** in the Route Macro Table –

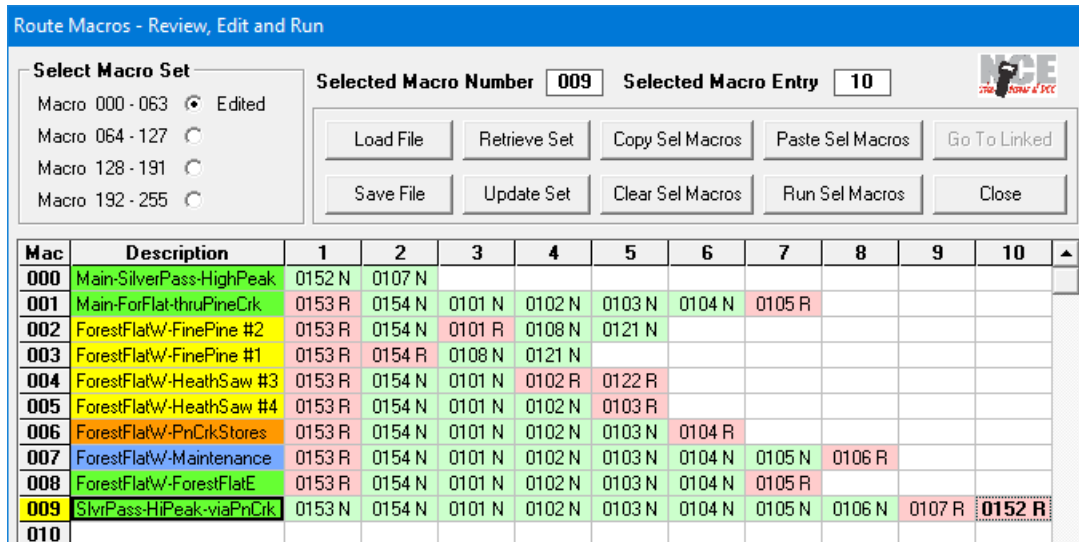

As a first example, to download a set of Macros from an NCE Power Pro Command Station, click on the appropriate option in the **Select Macro Set** area to select the Macro Set to retrieve, then click on the **Retrieve Set** button.

If the Macros in the Set which is selected have been edited, and not yet saved, a warning prompt will be displayed –

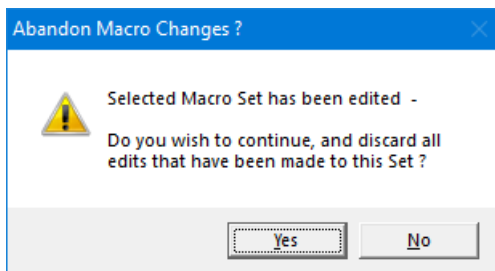

Click **No** to abandon the load process and take the opportunity to save whatever changes had been made to the Macros currently being displayed. Otherwise, click **Yes** to proceed, when the normal NCE Data Transfer progress bar will appear while Macros are being downloaded –

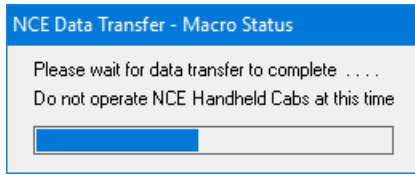

– after which the loaded Command Station Macros (if any) from Set 000 – 063 will be displayed –

Route Macros - Review, Edit and Run

Select Macro Set: Macro 000 - 063 Retrieved
 Macro 064 - 127
 Macro 128 - 191
 Macro 192 - 255

Selected Macro Number: 009 Selected Macro Entry: 2

Buttons: Load File, Retrieve Set, Copy Sel Macros, Paste Sel Macros, Go To Linked, Save File, Update Set, Clear Sel Macros, Run Sel Macros, Close

Mac	Description	1	2	3	4	5	6	7	8	9	10
000	Main-SilverPass-HighPeak	0101 N	0102 N	0103 N	0104 N	0105 R	0201 N	0204 N	0153 R	0154 N	
001	Main-ForFlat-thruPineCrk	0107 N	0131 N	0132 N	0141 R	0151 N	0152 N				
002	ForestFlatW-FinePine #2	0154 R	0108 R	0121 N							
003	ForestFlatW-FinePine #1	0154 N	0101 R	0108 N	0121 N	0122 N					
004	ForestFlatW-HeathSaw #3	0154 N	0101 N	0102 R	0122 R						
005	ForestFlatW-HeathSaw #4	0154 N	0101 N	0102 N	0103 R						
006	ForestFlatW-PnCrkStores	0154 N	0101 N	0102 N	0103 N	0104 R					
007	ForestFlatW-Maintenance	0154 N	0101 N	0102 N	0103 N	0104 N	0105 N	0106 R			
008	ForestFlatW-ForestFlatE										
009	SilverPass-HighPeak-viaPnCrk	0141 R	0151 N								

As can be seen, the retrieved Macros are different from those just defined and saved, either because they were loaded from a previously-defined backup file or were created manually using an NCE Handheld Cab – and they include turnouts located on the layout beyond the Pine Creek switching yard shown earlier in this Section.

Note that the Macro selection still remains as before (Macro 009), but that, more importantly, A-Track has retained the Descriptions and Background colours from the **previous** set of displayed Macros (see earlier in this Section). This is because **no Macro Descriptions** are stored in the Command Station, so that no new Descriptions can be loaded with the retrieved Macro data.

Although this is not a particularly useful feature in this case, it is more relevant after you have added proper Descriptions and Backgrounds to the loaded Command Station Macros and saved all of the data to a Route List. Subsequently, the normal way of using Macros with A-Track and an NCE Command Station would be to load the relevant Route List backup file, complete with Descriptions, edit the Macros as required, and then update the Macro Set(s) in the Command Station.

Alternatively, if Macros have been amended directly in the Command Station, using a Handheld Cab, the recommended way to proceed is to again load the Route List backup file(s), with the saved Macro Descriptions, and then reload the current Macros from the Command Station.

This will allow you to review the changes that have been made in the Command Station Macros, with the Descriptions providing a reminder of the Macros' functions, and to check that all of the Descriptions are still accurate, or to see where they need to

be amended. The updated Macros and Descriptions can then be saved to a (new) set of Route and/or Macro backup files on your computer’s hard disk or removable storage.

For the present example, you can first delete the Description attached to any blank Macro, such as Macro 008, by **right-clicking** on the Description in the Macro Grid, to highlight the text in the edit window, then pressing the **Del** (Delete) key to clear it.

Next, click the down arrow (▼) at the right of the **Description Background** listbox to drop down the list of colours, and click on White (or you can choose to leave the background colour as it is). Finally, press the **Enter/Return** key (or click the **Accept Edit** button) to complete the deletion.

To update the Macro Descriptions, right-click in the Description field of each displayed Command Station Macro, and then type in a suitable description (or edit the existing description) to replace the highlighted text in the **Macro Description** textbox of the edit window, select a **Description Background** colour if desired, and complete the edit by a click on the **Accept Edit** button or by pressing the **Enter/Return** key –

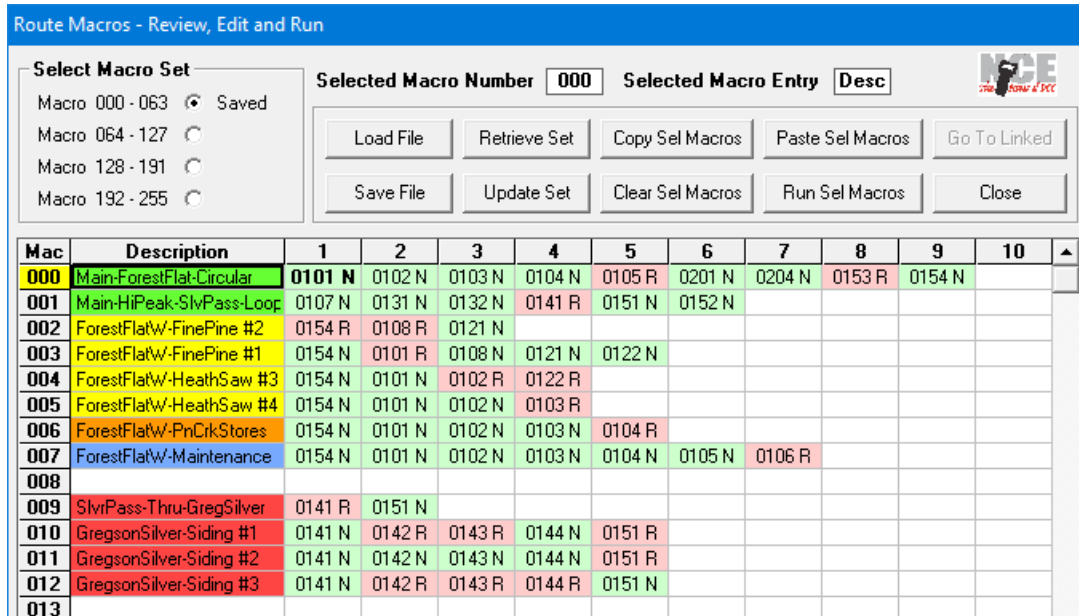

Note in passing that, if you hover over the NCE Logo in the top right corner of the Route Macro window, a note of the Macro Set just loaded will be displayed –

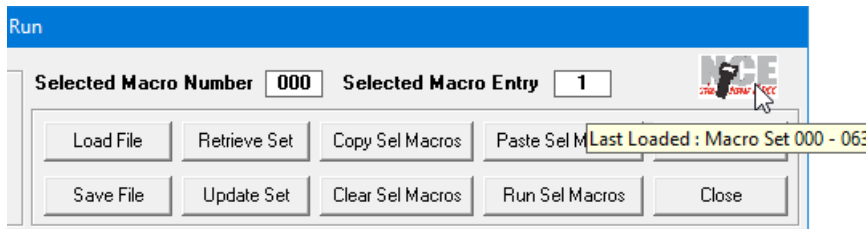

You can now save a backup copy of these Command Station Macros, as a Route List complete with revised **Descriptions** and **Background** colours, by clicking **Save File** and following the displayed prompts on the Save Macro Backup Data dialog, as described previously.

To continue the example, suppose that you wish to add a further route into the Pine Creek Yard, from the Forest Flat West entrance, via Siding #1, crossing Siding #2, and ending in Siding #3.

We can edit the currently-blank Macro 008 to incorporate this additional route by a **right-click** on any blank Entry of Macro 008, adding a **Description** and **Background** colour in the edit window, clicking in the **Address** textbox, and typing the required sequence of turnout commands, ie. '153r154r108r121r122n', ending with a press of the **Enter/Return** key –

Mac	Description	1	2	3	4	5	6	7	8	9	10
000	Main-ForestFlat-Circular	0101 N	0102 N	0103 N	0104 N	0105 R	0201 N	0204 N	0153 R	0154 N	
001	Main-HiPeak-SlvPass-Loop	0107 N	0131 N	0132 N	0141 R	0151 N	0152 N				
002	ForestFlatW-FinPine #1-2	0154 R	0108 R	0121 N							
003	ForestFlatW-FinPine #2-3	0154 N	0101 R	0108 N	0121 N	0122 N					
004	ForestFlatW-HeathSaw #3	0154 N	0101 N	0102 R	0122 R						
005	ForestFlatW-HeathSaw #4	0154 N	0101 N	0102 N	0103 R						
006	ForestFlatW-PnCkStores	0154 N	0101 N	0102 N	0103 N	0104 R					
007	ForestFlatW-Maintenance	0154 N	0101 N	0102 N	0103 N	0104 N	0105 N	0106 R			
008	ForestFlatW-Sidings#1-#3	0153 R	0154 R	0108 R	0121 R	0122 N					
009	SlvPass-Thru-GregSilver	0141 R	0151 N								
010	GregsonSilver-Siding #1	0141 N	0142 R	0143 R	0144 N	0151 R					
011	GregsonSilver-Siding #2	0141 N	0142 N	0143 N	0144 N	0151 R					
012	GregsonSilver-Siding #3	0141 N	0142 R	0143 R	0144 R	0151 N					
013											

After saving these edited Macros to a backup file, using **Save File** as before, but perhaps to a different filename than that used for the initial Set, you can upload the Macros to the NCE Power Pro Command Station, to replace the current Macros 000 to 063, by clicking on **Update Set**.

In order to minimise the probability of a data transfer error occurring as the Macro data is written to the Command Station memory, any locomotives currently under control should be brought to a halt, and no NCE Handheld Cabs should be operated thereafter until the data transfer is complete. A-Track will display a warning prompt as a reminder –

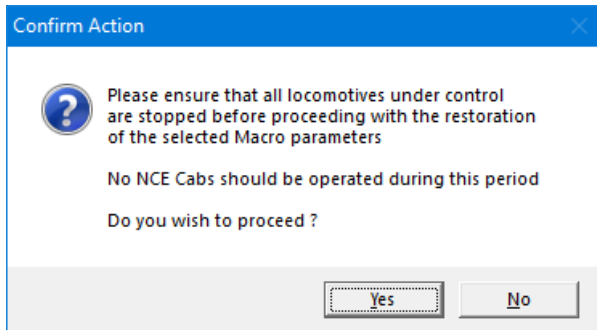

You now have the opportunity to bring everything on the layout to a controlled halt before you allow A-Track to proceed, by clicking the **Yes** button (or you can click **No** to abandon the Update operation).

After clicking **Yes**, you will see the normal NCE Data Transfer progress bar. The Update operation will take between 30 and 40 seconds to complete, after which you will see a confirmation prompt –

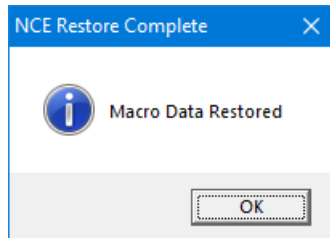

Click **OK** to continue.

Because both the Command Station and A-Track are carrying out their normal operations completely independently, there is a chance that data transfer errors can occur. Ideally, whenever A-Track sends a command to write backup data to the Command Station memory, the Command Station should suspend all of its own operations which involve the same area of memory. However, since there is no way that A-Track can request the Command Station to do this, the only option available to A-Track is to try to execute each part of the transfer so as to cause minimal interference, and to ensure that, if an error does occur, recovery of both systems is as painless as possible.

If a data transfer error does occur, a warning message will appear –

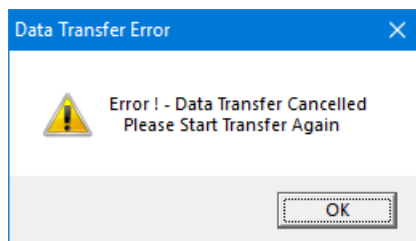

The error will most likely be due to some corruption in the A-Track transfer which has caused the NCE Command Station to stop processing the message, and then to wait indefinitely without sending a response back to A-Track.

In this case, after clicking **OK**, check whether both NCE and COM status indicators in the bottom righthand corner of the A-Track window are still **green**. If so, retry the data transfer operation.

Otherwise, or if the retry fails again, the recommended action is to close the A-Track program (saving your Macros if you have not already done so). Next **remove power** from the Command Station by unplugging it from the supply, **wait for 30 seconds** for the Command Station to fully reset itself (an NCE Power Pro takes about about 20 seconds after the red Status LED on the Command Station front panel stops flashing rapidly), then plug it back into the power supply. It should not be necessary to disconnect and reconnect the USB / Serial cable between the PC and the Command Station.

Restart A-Track and check that it completes its normal start-up sequence, with both NCE and COM status indicators in the bottom righthand corner of the A-Track window showing **green**. Then reload the Route Macro Table with the saved Macros and try the data transfer again.

When using an NCE Power Cab Version 1.65 system (including Power Booster and DCC Twin) a maximum of only 16 Macros, each consisting of up to 8 turnout commands, can be stored in the Command Station (compared to the NCE Power Pro storage capacity of up to 256 defined Macros, each consisting of up to 10 turnout commands).

With any of the Power Cab Version 1.65 systems, the **Retrieve Set** and **Update Set** buttons are only enabled when Macro Set 000 – 063 is selected in the **Select Macro Set** area (and will never be enabled when A-Track is connected to an NCE Power Cab Version 1.28 system, since this older system does not provide access to the Command Station internal memory).

Clicking **Retrieve Set** will download the contents (if any) of the 16 Macros stored in the Command Station to Macros 000 to 015 in the Route Macro Table. As usual, if the Macros currently in these positions have been edited, you will see a warning to allow you to save the edited Macros before overwriting them with the Command Station versions –

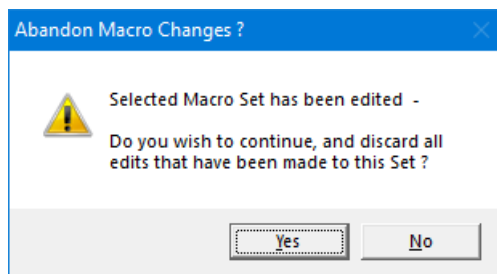

Note that each Macro in an NCE Power Cab system has only 8 Entries, so that Entries 9 and 10 in Macros 000 – 015 retrieved from the Command Station will be cleared.

Although Macros retrieved from an NCE Power Cab system are always loaded to Macros 000 – 015, you can transfer any group of 16 Macros from the 256 Macros displayed in the Route Macro Table to such a Command Station.

Start the transfer by clicking on the **Update Set** button. As with all transfers to the Command Station memory, in order to minimise the probability of a data transfer error, any locomotives currently under control should be brought to a halt, and no NCE Handheld Cabs should be operated until the data transfer is complete. A-Track will display a warning prompt as a reminder –

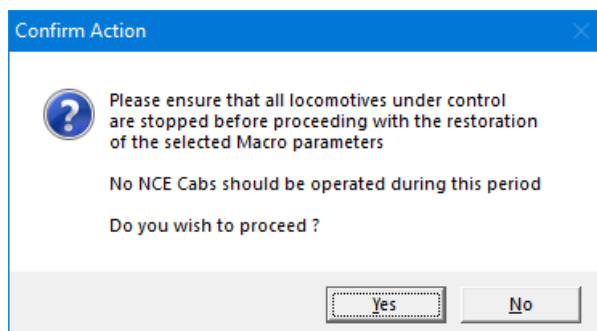

You now have the opportunity to bring everything on the layout to a controlled halt before you allow A-Track to proceed, by clicking the **Yes** button (or you can click **No** to abandon the Update operation).

A-Track will then ask you to confirm the number of the first Macro in the group of 16 Macros you wish to transfer to the Command Station, with the Macro number set initially at 000 –

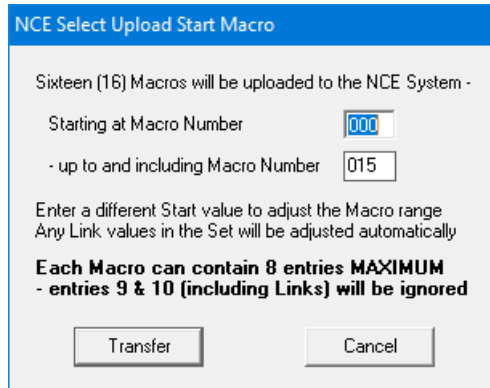

Follow the instruction on the prompt by typing the number of the first Macro to replace the '000' in the highlighted textbox (or leave it as it is), then click the **Transfer** button to begin the transfer, which will take between 30 and 40 seconds to complete, while the normal NCE Data Transfer progress bar is displayed, ending with a confirmation prompt –

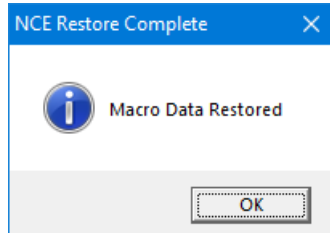

Click **OK** to continue.

Note, again, that only 8 Entries per Macro will be transferred to the NCE Power Cab system – any values in Entries 9 and/or 10 will be ignored. The values of any links between the Macros in the transferred group (see **Section 7.9** for an explanation of linking) will be adjusted to be correct when the transferred Macros are renumbered from 000 to 015.

If you are unsure of the number of the first Macro of the group to be uploaded to the Command station then, **before** clicking on the Route Macro Table **Update Set** button, scroll to the required Macro and select it by clicking on any of its Entries. Any Macro in the available Sets can be accessed by using the **mousewheel** or the **scroll bar** at the righthand margin to scroll through the full set of 256 Macros. Holding down either **Shift** (⇧) key while using the **mousewheel** will scroll by 16 Macros at a time, or you can use the **PageUp** and **PageDown** keys on the keyboard to go up or down by 24 Macros.

Once the right Macro is selected, click on the **Update Set** button. The number of the selected Macro will be shown in the **Start at Macro Number** textbox on the Upload prompt, and you can then click on the **Transfer** button to upload the selected Macro group to the Command Station.

While the NCE Power Cab Version 1.65 systems (including Smart Booster and DCC Twin), via the NCE USB Interface unit, allow you access to its set of 16 stored Macros, you must always be aware that any Macros which are transferred to the Command Station from A-Track **will not be retained** within the Command Station's memory after it is switched off. Such transferred Macros will, therefore, be lost whenever power to the Power Cab system is removed.

Because of this deficiency in Version 1.65 Power Cab, Smart Booster, and DCC Twin systems, A-Track incorporates a facility, as described later in **Section 9.1**, to save the complete status of such a Command Station as a backup file on your computer's hard disk, and to restore this status, including Macro definitions, automatically when A-Track and the associated Command Station are next switched on.

Without automatic restore enabled, A-Track will only be able to download from the Command Station whatever Macro definitions have been made previously with the NCE Cab controls – not necessarily those made and transferred earlier using A-Track. Note that you can, if you wish, avoid this complication by choosing to define and edit all Macros only in A-Track, activating them through the NCE Command Station when required, and not making any changes to Macros through the NCE Handheld Cabs.

7.9 Linking Macros

Although linking Macros is not strictly necessary in the example of the Pine Creek Yard, where there are only thirteen turnouts in total, and most switching combination can be accommodated within a single Macro, linking is useful in a layout where you need to switch more than eight or ten turnouts to set up a particular switching operation, and would like to do this with a single action.

Linking can also be used where one or more patterns of turnout positions are common to different switching operations, allowing you to reduce the amount of duplication when entering your Macro data.

Note that linking Macros, a facility provided by the NCE Command Station, is not the same as the linking of Turnouts, a facility supported by A-Track and described previously in **Section 7.2**. However, as covered later in this Section, both features can be combined to simplify the construction of your Macros.

For a simple example of how Macros are linked together, we can use using the set of Macros created in **Section 7.7** for the Pine Creek Yard. Suppose that, when any switching operations are in progress within the Pine Creek Yard, we want to ensure that the turnouts on the Silver Pass to High Peak mainline, passing Creek Sand & Gravel, are always set to bypass the Pine Creek Yard. Hence, after we execute Macro 002, for example, to set the route into Siding #2, we want to also execute Macro 000, to set the Yard bypass –

Mac	Description	1	2	3	4	5	6	7	8	9	10	▲
000	Main-SilverPass-HighPeak	0152 N	0107 N									
001	Main-ForFlat-thruPineCrk	0153 R	0154 N	0101 N	0102 N	0103 N	0104 N	0105 R				
002	ForestFlatW-FinePine #2	0153 R	0154 N	0101 R	0108 N	0121 N						
003	ForestFlatW-FinePine #1	0153 R	0154 R	0108 N	0121 N							
004	ForestFlatW-HeathSaw #3	0153 R	0154 N	0101 N	0102 R	0122 R						
005	ForestFlatW-HeathSaw #4	0153 R	0154 N	0101 N	0102 N	0103 R						
006	ForestFlatW-PnCrkStores	0153 R	0154 N	0101 N	0102 N	0103 N	0104 R					
007	ForestFlatW-Maintenance	0153 R	0154 N	0101 N	0102 N	0103 N	0104 N	0105 N	0106 R			
008	ForestFlatW-ForestFlatE	0153 R	0154 N	0101 N	0102 N	0103 N	0104 N	0105 R				
009	SlvrPass-HiPeak-viaPnCrk	0153 N	0154 N	0101 N	0102 N	0103 N	0104 N	0105 N	0106 N	0107 R	0152 R	

To link Macro 002 to Macro 000, **right-click** on any blank Entry at the end of Macro 002, which will open the edit window at Entry 6, as shown below. In the edit window click on the **Link to Route** option button, highlighting the Macro Number value in the **Address** textbox –

Mac	Description	1	2	3	4	5	6	7	8	9	10	▲
000	Main-SilverPass-HighPeak	0152 N	0107 N									
001	Main-ForFlat-thruPineCrk	0153 R	0154 N	0101 N	0102 N	0103 N	0104 N	0105 R				
002	ForestFlatW-FinePine #2	0153 R	0154 N	0101 R	0108 N	0121 N						
003	ForestFlatW-FinePine #1	0153 R	0154 R	0108 N	0121 N							
004	ForestFlatW-HeathSaw #3	0153 R	0154 N	0101 N	0102 R	0122 R						
005	ForestFlatW-HeathSaw #4	0153 R	0154 N	0101 N	0102 N	0103 R						
006	ForestFlatW-PnCrkStores	0153 R	0154 N	0101 N	0102 N	0103 N	0104 R					
007	ForestFlatW-Maintenance	0153 R	0154 N	0101 N	0102 N	0103 N	0104 N	0105 N	0106 R			
008	ForestFlatW-ForestFlatE	0153 R	0154 N	0101 N	0102 N	0103 N	0104 N	0105 R				
009	SlvrPass-HiPeak-viaPnCrk	0153 N	0154 N	0101 N	0102 N	0103 N	0104 N	0105 N	0106 N	0107 R	0152 R	
010												
011												
012												
013												
014												

Route Addresses

Turnout Addr Enter Value

Link to Route Address Normal Route

Address:

Macro Description: ForestFlatW-FinePine #2

Description Background: Yellow

Accept Edit Cancel

Next, from the keyboard, type the 3-digit number of the Macro to be linked so that it appears in the **Address** textbox. For this particular example we do not actually need to type '000', since that value is already there, but can then simply click **Accept Edit** (or press the **Enter/Return** key) to complete the operation. Entry 6 of Macro 002 will now contain '> 000' with a light blue background, as shown below –

Mac	Description	1	2	3	4	5	6	7	8	9	10	▲
000	Main-SilverPass-HighPeak	0152 N	0107 N									
001	Main-ForFlat-thruPineCrk	0153 R	0154 N	0101 N	0102 N	0103 N	0104 N	0105 R				
002	ForestFlatW-FinePine #2	0153 R	0154 N	0101 R	0108 N	0121 N	> 000					
003	ForestFlatW-FinePine #1	0153 R	0154 R	0108 N	0121 N							
004	ForestFlatW-HeathSaw #3	0153 R	0154 N	0101 N	0102 R	0122 R						
005	ForestFlatW-HeathSaw #4	0153 R	0154 N	0101 N	0102 N	0103 R						
006	ForestFlatW-PnCrkStores	0153 R	0154 N	0101 N	0102 N	0103 N	0104 R					
007	ForestFlatW-Maintenance	0153 R	0154 N	0101 N	0102 N	0103 N	0104 N	0105 N	0106 R			
008	ForestFlatW-ForestFlatE	0153 R	0154 N	0101 N	0102 N	0103 N	0104 N	0105 R				
009	SlvrPass-HiPeak-viaPnCrk	0153 N	0154 N	0101 N	0102 N	0103 N	0104 N	0105 N	0106 N	0107 R	0152 R	
010												

The result of this will be that, whenever you run Macro 002 (see **Section 7.11** which follows), Macro 000 will also be executed as soon as all of the turnout commands in Macro 002 have been sent to the Accessory decoder(s).

To illustrate the use of a Macro in more than one switching operation, we could also place a link to Macro 000 in Entry 5 of Macro 003, and in Entry 6 Of Macro 004, using the same sequence of edit actions as described above –

Route Macros - Review, Edit and Run

Select Macro Set
 Macro 000 - 063 Edited
 Macro 064 - 127
 Macro 128 - 191
 Macro 192 - 255

Selected Macro Number **004** Selected Macro Entry **6**

Load File Retrieve Set Copy Sel Macros Paste Sel Macros Go To Linked
 Save File Update Set Clear Sel Macros Run Sel Macros Close

Mac	Description	1	2	3	4	5	6	7	8	9	10	▲
000	Main-SilverPass-HighPeak	0152 N	0107 N									
001	Main-ForFlat-thruPineCrik	0153 R	0154 N	0101 N	0102 N	0103 N	0104 N	0105 R				
002	ForestFlatW-FinePine #2	0153 R	0154 N	0101 R	0108 N	0121 N	> 000					
003	ForestFlatW-FinePine #1	0153 R	0154 R	0108 N	0121 N	> 000						
004	ForestFlatW-HeathSaw #3	0153 R	0154 N	0101 N	0102 R	0122 R	> 000					
005	ForestFlatW-HeathSaw #4	0153 R	0154 N	0101 N	0102 N	0103 R						
006	ForestFlatW-PnCrikStores	0153 R	0154 N	0101 N	0102 N	0103 N	0104 R					
007	ForestFlatW-Maintenance	0153 R	0154 N	0101 N	0102 N	0103 N	0104 N	0105 N	0106 R			
008	ForestFlatW-ForestFlatE	0153 R	0154 N	0101 N	0102 N	0103 N	0104 N	0105 R				
009	SilverPass-HiPeak-viaPnCrik	0153 N	0154 N	0101 N	0102 N	0103 N	0104 N	0105 N	0106 N	0107 R	0152 R	
010												

Hence, whenever you run any of Macros 002, 003, or 004 to set routes into the Pine Creek Yard, the Mainline from Silver Pass to High Peak will always be set to bypass the Yard, and leave full access to the Pine Creek Yard sidings for a locomotive (either on its own, or with a short train) coming from Forest Flat.

As you can see in the above example, when a Macro containing a link is selected, an additional button, **Go To Linked**, is enabled. Clicking on this button, or pressing **Ctrl-L** (hold down either Control key, then press the 'L' key) will change the current Macro selection to the Macro pointed to by the link which, in this case, is Macro 000. While not particularly useful here, where all the Macros concerned are in view, it is of more use when the linked Macro is off-screen, or in a different Macro Set.

As an illustration of this, suppose that, when the route from the Mainline to Silver Pass is selected, by executing Macro 000, we would like to ensure that the route through Silver Pass is set for through traffic, and that the relevant Macro for this route is Macro 072. A link to Macro 072 is added, therefore, by right-clicking in any blank Entry of Macro 000 and typing in the appropriate link address '072', as shown below –

Mac	Description	1	2	3	4	5	6	7	8	9	10	▲
000	Main-SilverPass-HighPeak	0152 N	0107 N	> 072								
001	Main-ForFlat-thruPineCrik	0153 R	0154 N	0101 N	0102 N	0103 N	0104 N	0105 R				
002	ForestFlatW-FinePine #2	0153 R	0154 N	0101 R	0108 N	0121 N	> 000					
003	ForestFlatW-FinePine #1	0153 R	0154 R	0108 N	0121 N	> 000						
004	ForestFlatW-HeathSaw #3	0153 R	0154 N	0101 N	0102 R	0122 R	> 000					
005	ForestFlatW-HeathSaw #4	0153 R	0154 N	0101 N	0102 N	0103 R						
006	ForestFlatW-PnCrikStores	0153 R	0154 N	0101 N	0102 N	0103 N	0104 R					
007	ForestFlatW-Maintenance	0153 R	0154 N	0101 N	0102 N	0103 N	0104 N	0105 N	0106 R			
008	ForestFlatW-ForestFlatE	0153 R	0154 N	0101 N	0102 N	0103 N	0104 N	0105 R				
009	SilverPass-HiPeak-viaPnCrik	0153 N	0154 N	0101 N	0102 N	0103 N	0104 N	0105 N	0106 N	0107 R	0152 R	
010												

Having done this, and assuming that Macro 072 has been set up and/or loaded previously, click on **Go To Linked** (or press **Ctrl-L**). This action will jump to the appropriate Macro Set in the Macro Grid, and highlight Macro 072 –

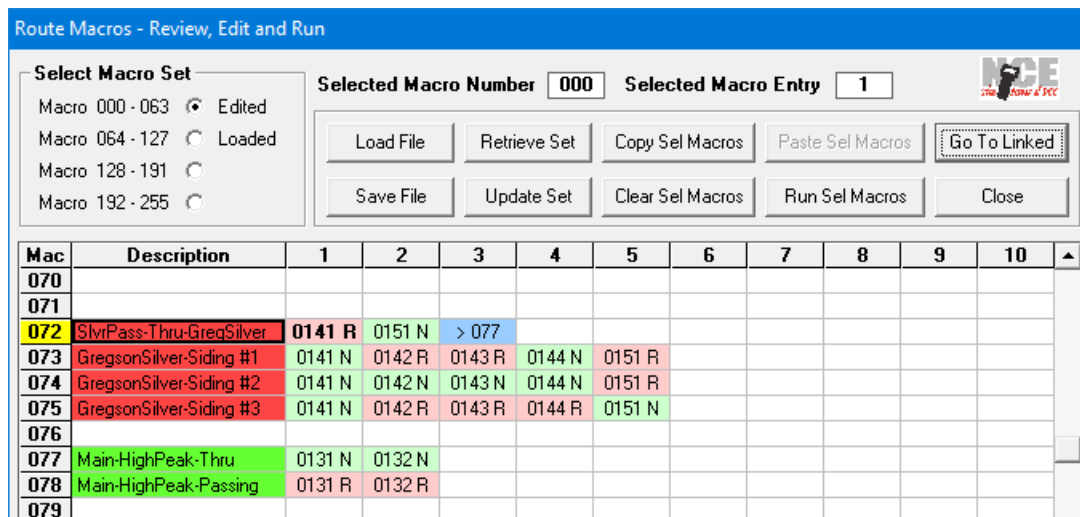

You can see that Macro 072 is itself linked to yet another Macro (Macro 077). There is no limit placed on the number of Macros which may be linked together, but you need to take care that you do not accidentally add a link at the end of the current Macro which points to a Macro which itself contains a link, directly or via other linked Macros, back to the current Macro. Such an action would create a closed loop and, if loaded to the NCE Power Pro Command Station, will seriously disrupt operation of the NCE system when any of the linked Macros is executed. This is dealt with further in **Section 7.11**.

If you do have a set of linked Macros, you can check that no disruptive loop has been created, before running the Macros, by stepping through the sequence using the **Go To Linked** button (or pressing **Ctrl-L**) and verifying that the sequence does come to a halt.

To **change** a link, right-click on the Entry containing the link, type the number of the new Macro to be linked to the selected Macro on the keyboard, so that the new number appears in the **Address** textbox in the edit window (replacing the highlighted previous Macro number), then click the **Accept Edit** button (or press the **Enter/Return** key).

To completely **remove** a link from a Macro, right-click on the Entry containing the link, left-click on the **Turnout Addr** option button in the edit window, which will replace the current linked Macro number in the **Address** textbox with a highlighted value '0000', then click the **Accept Edit** button (or press the **Enter/Return** key).

When you are satisfied with your Macro contents and structure, do not forget to save the defined Macros to your PC's hard disk, or to removable storage, as one or more Route List or Macro Backup files, as explained in the preceding **Section 7.7**.

A particular use of linked Macros, where you have a reasonably large layout with more than 10 turnouts, is to check the operation of all turnouts on your layout before an operating session. An example of such linked Macros to check a layout having 28 turnouts is shown below. Here, Macros 022, 023, 024, and 025 are linked so that when

Macro 022 is run, commands are sent to all 28 turnouts to set them in the Normal direction. Similarly, executing Macro 027 will output commands to set all turnouts in the Route direction, via linked Macros 028, 029, and 030 –

Mac	Description	1	2	3	4	5	6	7	8	9	10	▲
021												
022	Check-AllTurnouts-SetN-1	0101 N	0102 N	0103 N	0104 N	0105 N	0106 N	0107 N	0108 N	> 023		
023	Check-AllTurnouts-SetN-2	0121 N	0122 N	0131 N	0132 N	0141 N	0142 N	0143 N	0144 N	> 024		
024	Check-AllTurnouts-SetN-3	0151 N	0152 N	0153 N	0154 N	> 025						
025	Check-AllTurnouts-SetN-4	0201 N	0202 N	0203 N	0204 N	0211 N	0212 N	0221 N	0222 N			
026												
027	Check-AllTurnouts-SetR-1	0101 R	0102 R	0103 R	0104 R	0105 R	0106 R	0107 R	0108 R	> 028		
028	Check-AllTurnouts-SetR-2	0121 R	0122 R	0131 R	0132 R	0141 R	0142 R	0143 R	0144 R	> 029		
029	Check-AllTurnouts-SetR-3	0151 R	0152 R	0153 R	0154 R	> 030						
030	Check-AllTurnouts-SetR-4	0201 R	0202 R	0203 R	0204 R	0211 R	0212 R	0221 R	0222 R			
031												

When pairs of turnouts, with each turnout driven by a separate Accessory Decoder Output, are linked using the A-Track facility described in **Section 7.2**, you need to be aware that this may result in duplicated commands being sent to the relevant Accessory Decoder. This will only occur when Macros such as those shown above are executed directly from A-Track (see **Section 7.11**), but not when the Macros are uploaded to the Command Station and run from a Handheld Cab.

Taking the example of the two cross-linked pairs of turnouts at the Forest Flat sidings, as presented in **Section 7.2** –

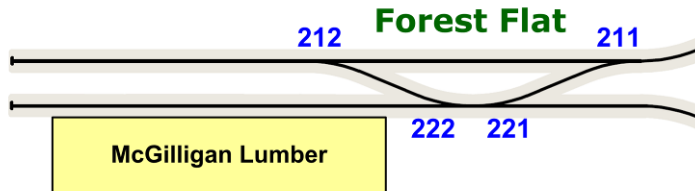

– when Macro 025 is run and command **'0211 N'** is output, A-Track will generate an additional command **'0221 N'**, since turnouts 0211 and 0221 are linked. A little later, when the Macro causes command **'0221 N'** to be output, A-Track will generate a further command **'0211 N'**, so that both turnouts will be set twice in the Normal direction. This is not a particular problem here, since the final settings of the turnouts will be as expected, but can cause confusion if turnouts are linked in a Reverse sense.

To illustrate what can happen if turnouts are Reverse linked, consider the case of two turnouts, 0121 and 0122, in the Pine Creek Yard, which might be so linked –

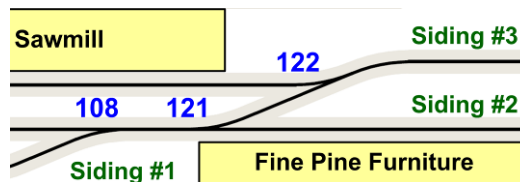

Here, when Macro 028 is executed, for example, the first command **'0121 R'** sets turnout 0121 in the Route direction, then causes A-Track to output an additional command **'0122 N'**, setting turnout 0122 in the Normal direction. However, the

following command output by Macro 028, '**0122 R**' will reset turnout 0122 to the Route direction, followed by A-Track generating an additional command '**0121 N**' which flips turnout 0121 back to the Normal direction – preventing Macro 028 from achieving its objective of setting all turnouts in the Route direction.

This behaviour need not be a problem as long as you are aware of it. The general recommendation is that, where pairs of turnouts are linked in the A-Track Accessory Item setup, you only include commands for one turnout of the pair in any relevant Macro, or linked set of Macros, where these Macros are intended to be run directly from A-Track, rather than from the Command Station via a Handheld Cab (see **Section 7.11** for details of running Macros).

Another situation you may encounter is where you have a pair of turnouts, with both turnouts driven from the same Accessory Decoder Output, and they are again linked using the A-Track facility described in **Section 7.2**. In this case, one of the turnouts is identified with an address equal to the Output Address **plus 3000** (normal accessory addresses have a maximum value of 2044). The example below illustrates the situation, where both turnout motors are driven from the same NCE Snap-It accessory decoder whose single output has been assigned the address 0121 –

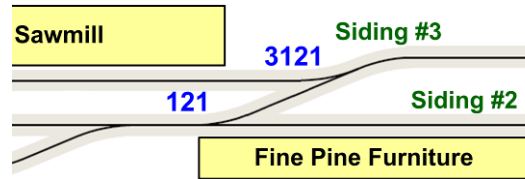

Although, here, there is no problem of duplicate Macro commands, be aware of the case, as above, where the turnouts are linked in reverse. Hence, to set turnout 3121 in the Normal direction, the required Macro command will be '**0121 R**', and *vice versa*, with turnout 0121 being set simultaneously in the opposite direction to turnout 3121.

Note, however, if you enter the linked address (3121) rather than the primary address (0121) as the Macro command then it will be rejected with an error message –

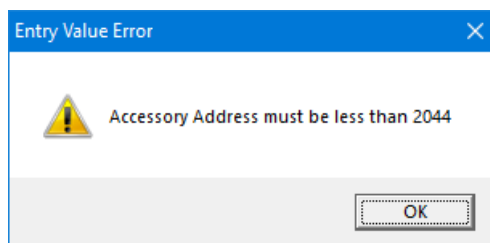

Click **OK** to continue and enter the primary address instead.

7.10 Macro Group Operations

As well as the single Macro 'copy and paste' option introduced in **Section 7.7**, A-Track allows you select multiple Macros as a group, which can then be copied and pasted to any other location within the same, or another, Macro Set. The facility can also be used to execute the selected group of Macros with a single action, without having to link the Macros together explicitly, as described further in **Section 7.11**.

To select a group of Macros, click anywhere on the *first* Macro in the desired group, ie. on any Entry, the Description, or on the Macro number in the **Mac** column, hold down either **Shift** (⇧) key on your keyboard, and then click anywhere on the *last* Macro to be included in the group.

All of the Macros between first and last will be highlighted in **yellow**, as shown below for Macros 000 through 006. Click the **Copy Sel Macros** button or press **Ctrl-C** (hold down either Control key, then press the 'C' key) to copy the selected group to an internal storage buffer –

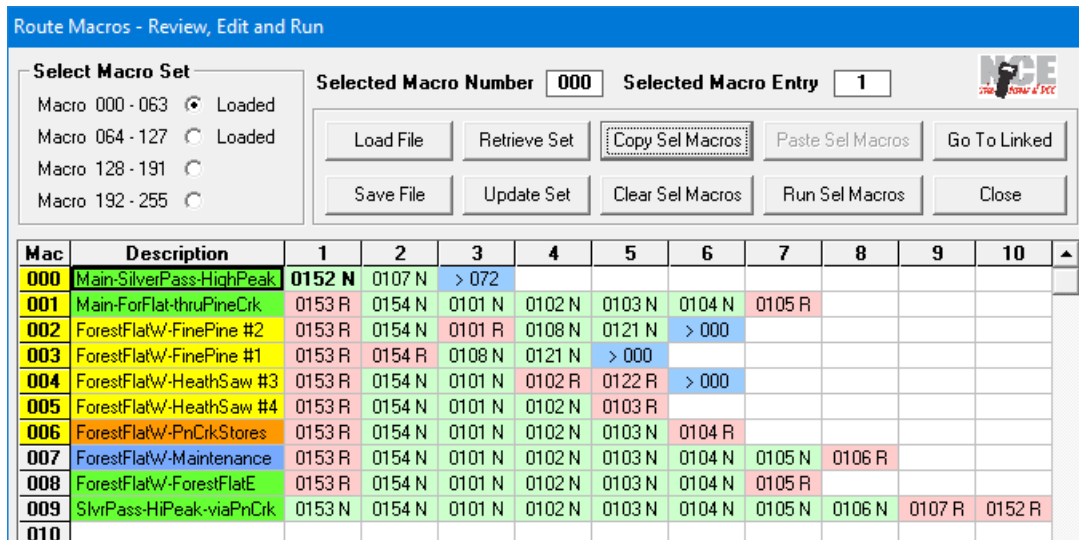

To paste a copy of the selected group anywhere within the Macro Sets, click on a target Set, such as **Macro 064 – 127**, in the **Select Macro Set** area or, if you are pasting elsewhere in the current Set, just scroll down to the required location, using the **mousewheel**, with or without a **Shift** key (to scroll by 16 Macros at a time), or the scrollbar at the righthand side, or you can use the **PageUp** and **PageDown** keys on the keyboard to go up or down by 24 Macros.

Next, click on the first Macro of the destination group, such as Macro 080, then click the **Paste Sel Macros** button or press **Ctrl-V** (hold down either Control key, then press the 'V' key), to transfer the copied Macros, including the associated Descriptions and Links, to the selected location –

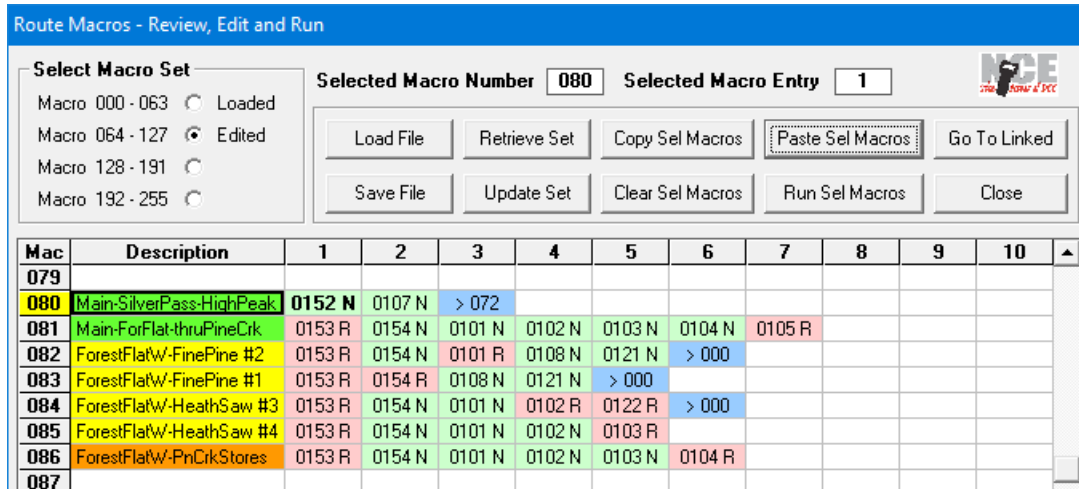

You can select individual Macros, or add additional Macros to a selected block of Macros, by holding down either **Ctrl** (Control) key on the keyboard and clicking anywhere within the Macro to be added to the selection. The same action will also **deselect** any selected Macro, removing it from the selected group.

Starting from the original group of Macros 000 to 009, the result of clicking on Macros 000, 002, 003, 004, 007, and 009, with a **Ctrl** key held down, is shown below, with the selected Macros again highlighted in **yellow** -

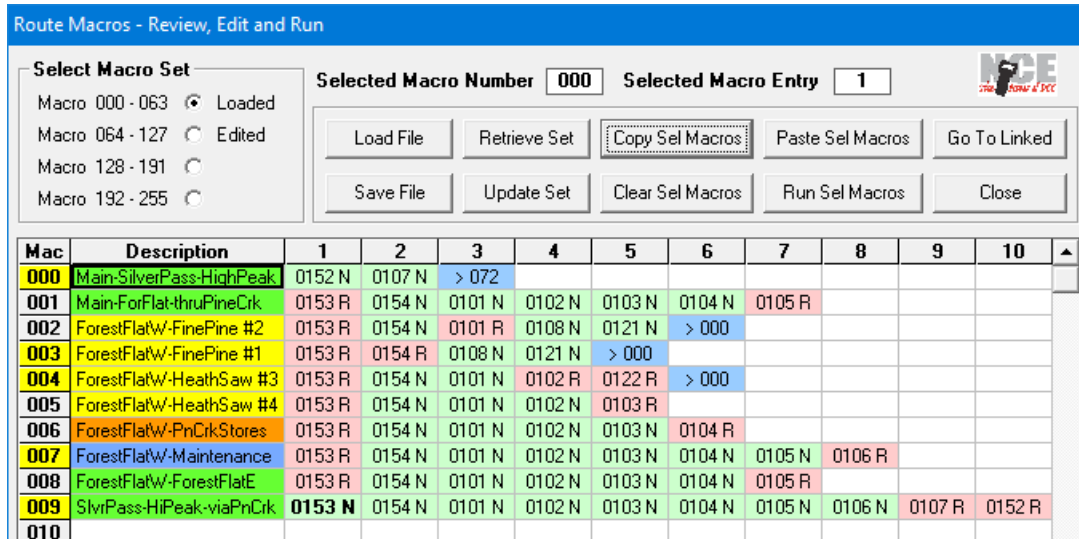

Compared to the previous selection, Macros 007 and 009 have been added to the selected group, whereas Macros 001, 002, 005 and 006 have been removed.

If you now click the **Copy Sel Macros** button (or press **Ctrl-C**), then move to select a destination, say Macro 095, followed by a click on the **Paste Sel Macros** button (or press **Ctrl-V**), the result will be as shown below -

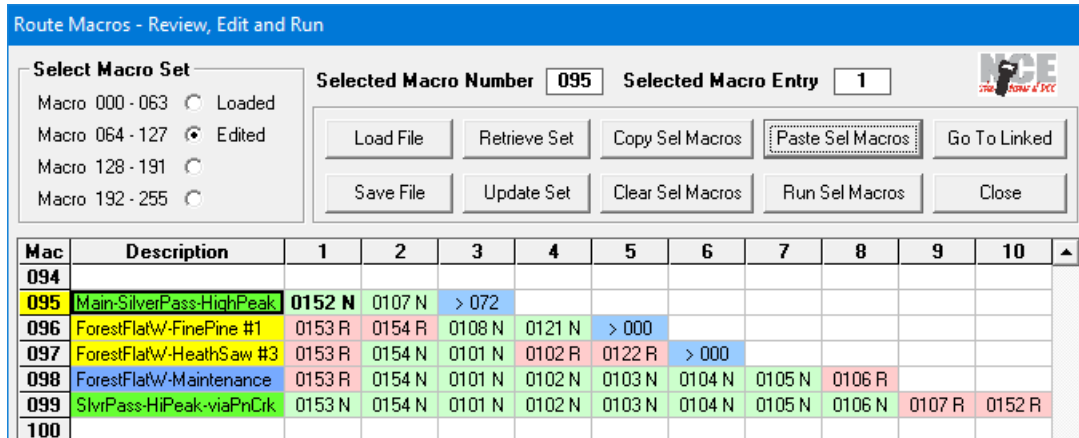

One important point to note here is that the copied Macros are copied to the selected destination as a single, contiguous group, without any intervening blank Macros, regardless of the relative positions or numbering of the original copied Macros.

The copy of the selected Macros remains in the internal storage buffer, so that you can paste it to another location if you wish, until you replace it by another Copy operation. This is also the case if you choose to **Close** the Route Macro Table window – the window is simply hidden and the contents of the storage buffer are preserved for further use. It is also perfectly feasible to load another Route List or Macro Backup file and then add the Macros saved in the storage buffer to it, before saving the combined set of Macros to another file.

As well as copying Macros from one location to another, you can also use the multiple selection facility to **erase** any number of Macros from the currently loaded Sets. Just select all of the Macros to be deleted, then click the **Clear Sel Macros** button or press **Ctrl-Delete** (hold down either Control key, then press the 'Delete' or 'Del' key). A warning is displayed, asking you to confirm the deletion –

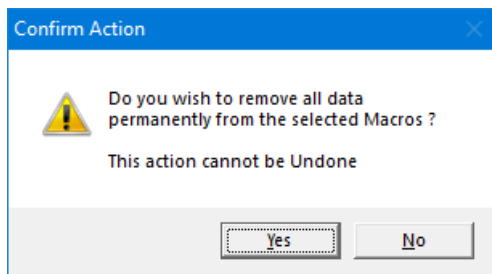

Click **Yes** to erase the selected Macros, or **No** to abandon the operation.

Important Note : In the current release of A-Track there is **no Undo facility for Macro edits**. Any change you make is **not** reversible, so make sure that you save your created Macro files frequently as insurance against inadvertent editing errors.

If you wish to **move** a group of Macros from one place in the Route Macro Table to another, you can do this by first selecting the Macros to be moved as described previously, then press **Ctrl-X** (hold down either Control key, then press the 'X' key). This will copy the Macro group to the internal storage buffer, from where it remains available for you to paste it back to any position in the Route Macro Table, and will

then delete the selected Macros from their current positions, after you confirm the action by clicking the **Yes** button on the warning message (as shown above). Note that, if you click the **No** button, the selected macros will still be copied to the buffer, but will not be erased from the Table.

Whilst the single Macro copy and paste function is useful when creating similar Macros within a group, the main intention behind providing multiple Macro copy and paste facilities is to allow you to move small groups of Macros, for use in a specific switching operation, for example, into a single Macro Set so that the related groups can be saved in a single file.

As an example, we could transfer the Silver Pass Macros in Macro Set 064-127, introduced in the previous **Section 7.9**, into the same Set as the Pine Creek Yard Macros, used in the examples here. This could be, perhaps, to transfer the complete group to an NCE Power Cab Command Station intended to control switching operations associated with freight traffic between the Pine Creek industries and Gregson Silver at Silver Pass.

Assuming we have both groups of Macros loaded, click the **Macro 064 – 127** option in the **Select Macro Set** area to bring the Silver Pass Macros into view. Click on Macro 072, hold down either **Shift** key, and click on Macro 075 to select the first Macro group, then hold down either **Ctrl** (Control) key and click on Macros 077 and 078 in turn to add them to the selected group –

Mac	Description	1	2	3	4	5	6	7	8	9	10
070											
071											
072	SivrPass-Thru-GregSilver	0141 R	0151 N	> 077							
073	GregsonSilver-Siding #1	0141 N	0142 R	0143 R	0144 N	0151 R					
074	GregsonSilver-Siding #2	0141 N	0142 N	0143 N	0144 N	0151 R					
075	GregsonSilver-Siding #3	0141 N	0142 R	0143 R	0144 R	0151 N					
076											
077	Main-HighPeak-Thru	0131 N	0132 N								
078	Main-HighPeak-Passing	0131 R	0132 R								
079											

Click **Copy Sel Macros**, then click the **Macro 000 – 063** option in the **Select Macro Set** area to return to the Pine Creek Macros. Click on the Macro you wish to use as the destination for the copied Macro group, such as Macro 010, then click the **Paste Sel Macros** button to complete the copy operation –

Route Macros - Review, Edit and Run

Select Macro Set

- Macro 000 - 063 Edited
- Macro 064 - 127 Loaded
- Macro 128 - 191
- Macro 192 - 255

Selected Macro Number Selected Macro Entry

Mac	Description	1	2	3	4	5	6	7	8	9	10	▲
000	Main-SilverPass-HighPeak	0152 N	0107 N	> 072								
001	Main-ForFlat-thruPineCrk	0153 R	0154 N	0101 N	0102 N	0103 N	0104 N	0105 R				
002	ForestFlatW-FinePine #2	0153 R	0154 N	0101 R	0108 N	0121 N	> 000					
003	ForestFlatW-FinePine #1	0153 R	0154 R	0108 N	0121 N	> 000						
004	ForestFlatW-HeathSaw #3	0153 R	0154 N	0101 N	0102 R	0122 R	> 000					
005	ForestFlatW-HeathSaw #4	0153 R	0154 N	0101 N	0102 N	0103 R						
006	ForestFlatW-PnCrkStores	0153 R	0154 N	0101 N	0102 N	0103 N	0104 R					
007	ForestFlatW-Maintenance	0153 R	0154 N	0101 N	0102 N	0103 N	0104 N	0105 N	0106 R			
008	ForestFlatW-ForestFlatE	0153 R	0154 N	0101 N	0102 N	0103 N	0104 N	0105 R				
009	SivrPass-HiPeak-viaPnCrk	0153 N	0154 N	0101 N	0102 N	0103 N	0104 N	0105 N	0106 N	0107 R	0152 R	
010	SivrPass-Thru-GregSilver	0141 R	0151 N	> 077								
011	GregsonSilver-Siding #1	0141 N	0142 R	0143 R	0144 N	0151 R						
012	GregsonSilver-Siding #2	0141 N	0142 N	0143 N	0144 N	0151 R						
013	GregsonSilver-Siding #3	0141 N	0142 R	0143 R	0144 R	0151 N						
014	Main-HighPeak-Thru	0131 N	0132 N									
015	Main-HighPeak-Passing	0131 R	0132 R									
016												

A-Track does not incorporate any automatic facility to amend any link addresses to reflect the new locations of the copied Macros, so you will need to do this manually, so that the link in Macro 000 will point to the relocated Macro 010, rather than to its previous position at Macro 072, and Macro 010 should now link to Macro 014 instead of Macro 077.

Adjust the link addresses by a right-click on the Entry containing the link address, opening an edit window with the current link address highlighted in the Address textbox. Simply type the new link address from the keyboard to replace the highlighted value, then click the **Accept Edit** button (or press the **Enter/Return** key) to complete the operation -

Mac	Description	1	2	3	4	5	6	7	8	9	10	▲
000	Main-SilverPass-HighPeak	0152 N	0107 N	> 072								
001	Main-ForFlat-thruPineCrk	0153 R	0154 N	0101 N	0102 N	0103 N	0104 N	0105 R				
002	ForestFlatW-FinePine #2	0153 R	0154 N	0101 R	0108 N	0121 N	> 000					
003	ForestFlatW-FinePine #1	0153 R	0154 R	0108 N	0121 N	> 000						
004	ForestFlatW-HeathSaw #3	0153 R	0154 N	0101 N	0102 R	0122 R	> 000					
005	ForestFlatW-HeathSaw #4	0153 R	0154 N	0101 N	0102 N	0103 R						
006	ForestFlatW-PnCrkStores	0153 R	0154 N	0101 N	0102 N	0103 N	0104 R					
007	ForestFlatW-Maintenance	0153 R	0154 N	0101 N	0102 N	0103 N	0104 N	0105 N	0106 R			
008	ForestFlatW-ForestFlatE	0153 R	0154 N	0101 N	0102 N	0103 N	0104 N	0105 R				
009	SivrPass-HiPeak-viaPnCrk	0153 N	0154 N	0101 N	0102 N	0103 N	0104 N	0105 N	0106 N	0107 R	0152 R	
010	SivrPass-Thru-GregSilver	0141 R	0151 N	> 077								
011	GregsonSilver-Siding #1	0141 N	0142 R	0143 R	0144 N	0151 R						
012	GregsonSilver-Siding #2	0141 N	0142 N	0143 N	0144 N	0151 R						
013	GregsonSilver-Siding #3	0141 N	0142 R	0143 R	0144 R	0151 N						
014	Main-HighPeak-Thru	0131 N	0132 N									
015	Main-HighPeak-Passing	0131 R	0132 R									
016												

Route Addresses

Turnout Addr Address Normal

Link to Route Route

Macro Description Main-SilverPass-HighPeak

Description Background Green

The final state of the Macro group, with adjusted link addresses, should be as shown below -

Route Macros - Review, Edit and Run

Select Macro Set

- Macro 000 - 063 Edited
- Macro 064 - 127 Loaded
- Macro 128 - 191
- Macro 192 - 255

Selected Macro Number Selected Macro Entry

Mac	Description	1	2	3	4	5	6	7	8	9	10	▲
000	Main-SilverPass-HighPeak	0152 N	0107 N	> 010								
001	Main-ForFlat-thruPineCrik	0153 R	0154 N	0101 N	0102 N	0103 N	0104 N	0105 R				
002	ForestFlatW-FinePine #2	0153 R	0154 N	0101 R	0108 N	0121 N	> 000					
003	ForestFlatW-FinePine #1	0153 R	0154 R	0108 N	0121 N	> 000						
004	ForestFlatW-HeathSaw #3	0153 R	0154 N	0101 N	0102 R	0122 R	> 000					
005	ForestFlatW-HeathSaw #4	0153 R	0154 N	0101 N	0102 N	0103 R						
006	ForestFlatW-PnCrkStores	0153 R	0154 N	0101 N	0102 N	0103 N	0104 R					
007	ForestFlatW-Maintenance	0153 R	0154 N	0101 N	0102 N	0103 N	0104 N	0105 N				
008	ForestFlatW-ForestFlatE	0153 R	0154 N	0101 N	0102 N	0103 N	0104 N	0105 R				
009	SivrPass-HiPeak-viaPnCrk	0153 N	0154 N	0101 N	0102 N	0103 N	0104 N	0105 N	0106 N	0107 R	0152 R	
010	SivrPass-Thru-GregSilver	0141 R	0151 N	> 014								
011	GregsonSilver-Siding #1	0141 N	0142 R	0143 R	0144 N	0151 R						
012	GregsonSilver-Siding #2	0141 N	0142 N	0143 N	0144 N	0151 R						
013	GregsonSilver-Siding #3	0141 N	0142 R	0143 R	0144 R	0151 N						
014	Main-HighPeak-Thru	0131 N	0132 N									
015	Main-HighPeak-Passing	0131 R	0132 R									
016												

Link Addresses Amended Manually

Note that, in the previous examples, where various selected Macros from the Pine Creek Yard group were copied to Macro 080 and Macro 095, the links to the original Macro 000 would also need to be adjusted in a similar manner to that above, to point to either Macro 080 or Macro 095 as appropriate.

7.11 Executing Macros and Running Routes

A-Track allows Macros to be executed directly from any loaded Route List or Macro Backup file, when using either an NCE Power Cab or an NCE Power Pro system, in order to set, or run, a selected Route.

To run a Route from a loaded file, open the Route Macro Table window by going to the **Route** menu, and clicking on the first option, **Display Route Macro Table**, or by clicking on the  icon on the Toolbar. Click on **Load File** and load the relevant file from the computer's hard disk or other media.

Once the Macros are loaded into the appropriate Macro Set(s), click on the Macro you wish to run in order to select it, such as Macro 007, and then click the **Run Sel Macros** button in the top section of the window, or press **Ctrl-R** (hold down either Control key, then press the 'R' key) -

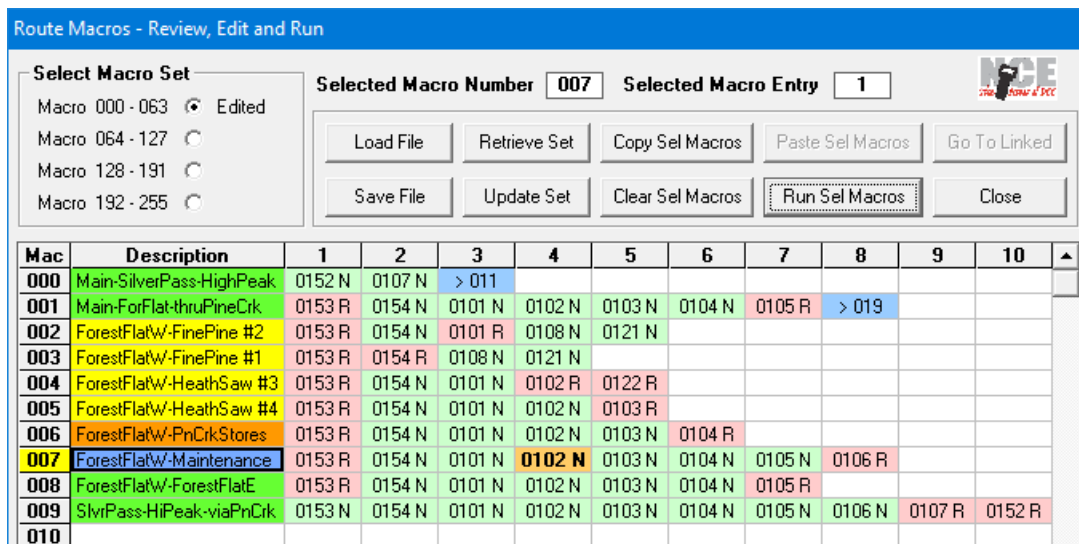

Route Macros - Review, Edit and Run

Select Macro Set: Macro 000 - 063 (Selected), Macro 064 - 127, Macro 128 - 191, Macro 192 - 255

Selected Macro Number: 007 Selected Macro Entry: 1

Buttons: Load File, Retrieve Set, Copy Sel Macros, Paste Sel Macros, Go To Linked, Save File, Update Set, Clear Sel Macros, Run Sel Macros, Close

Mac	Description	1	2	3	4	5	6	7	8	9	10
000	Main-SilverPass-HighPeak	0152 N	0107 N	> 011							
001	Main-ForFlat-thruPineCrik	0153 R	0154 N	0101 N	0102 N	0103 N	0104 N	0105 R	> 019		
002	ForestFlatW-FinePine #2	0153 R	0154 N	0101 R	0108 N	0121 N					
003	ForestFlatW-FinePine #1	0153 R	0154 R	0108 N	0121 N						
004	ForestFlatW-HeathSaw #3	0153 R	0154 N	0101 N	0102 R	0122 R					
005	ForestFlatW-HeathSaw #4	0153 R	0154 N	0101 N	0102 N	0103 R					
006	ForestFlatW-PnCrikStores	0153 R	0154 N	0101 N	0102 N	0103 N	0104 R				
007	ForestFlatW-Maintenance	0153 R	0154 N	0101 N	0102 N	0103 N	0104 N	0105 N	0106 R		
008	ForestFlatW-ForestFlatE	0153 R	0154 N	0101 N	0102 N	0103 N	0104 N	0105 R			
009	SilverPass-HiPeak-viaPnCrik	0153 N	0154 N	0101 N	0102 N	0103 N	0104 N	0105 N	0106 N	0107 R	0152 R
010											

A-Track scans the full list of Macros and then, for each selected Macro, generates a turnout (Accessory) command for each Entry making up the Macro in sequence. The commands are loaded to an output queue, and then sent to the Command Station at a rate of approximately 3 per second. As each command is output, A-Track briefly marks the corresponding Macro Entry with an **orange** highlight, as can be seen above for command '0102 N' in Entry 4 of Macro 007.

Note that the **Run Sel Macros** button (or the **Ctrl-R** keyboard shortcut) is only enabled if a Command Station is connected when the Route Macro Table window is opened. However, if the connection has subsequently been lost for any reason, you will see a warning message when the **Run Sel Macros** button is clicked (or **Ctrl-R** is pressed) -

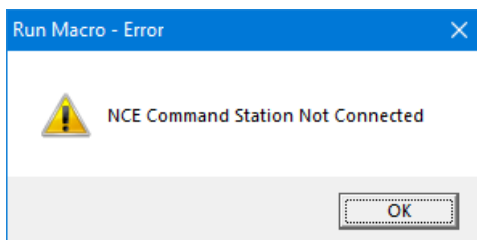

Click **OK** to terminate the operation and return to the Route Macro Table window. Check your connections and, when communications are re-established, try running the Macro again.

If a Macro selected for execution contains a **link** to another Macro, such as Macro 019 in the example above, the linked Macro (Macro 008) will be executed immediately after the Accessory commands in Macro 019 have been sent to the Command Station. This applies for as many Macros as you wish to link together so that, if we run Macro 000 first, the links in place will result in Macros 011, 016, 019, and 008 being run as well.

As well as executing single Macros, A-Track allows you to run as many Macros as you wish to select from any loaded Macros in a single operation, without necessarily requiring the Macros to be linked together. This provides a great deal more flexibility in executing sequences of Macros, compared to the facilities available with an NCE Handheld Cab and the use of fixed Macro links.

Click on the first Macro you wish to run, hold down either **Ctrl** (Control) key and then click on each additional Macro to be executed. When your selection is complete, click the **Run Sel Macros** button (or press **Ctrl-R**), and the selected Macros, together with any other Macros to which they are linked, will then be run in numerical order (regardless of the order in which they were selected).

As a simple example, suppose Macros 000 and 001 have been selected, as below –

Route Macros - Review, Edit and Run

Select Macro Set: Macro 000 - 063 Loaded
 Macro 064 - 127
 Macro 128 - 191
 Macro 192 - 255

Selected Macro Number: Selected Macro Entry:

Buttons: Load File, Retrieve Set, Copy Sel Macros, Paste Sel Macros, Go To Linked, Save File, Update Set, Clear Sel Macros, Run Sel Macros, Close

Mac	Description	1	2	3	4	5	6	7	8	9	10
000	Main-SilverPass-HighPeak	0152 N	0107 N	> 011							
001	Main-ForFlat-thruPineCrk	0153 R	0154 N	0101 N	0102 N	0103 N	0104 N	0105 R	> 019		
002	ForestFlatW-FinePine #2	0153 R	0154 N	0101 R	0108 N	0121 N					
003	ForestFlatW-FinePine #1	0153 R	0154 R	0108 N	0121 N						
004	ForestFlatW-HeathSaw #3	0153 R	0154 N	0101 N	0102 R	0122 R					
005	ForestFlatW-HeathSaw #4	0153 R	0154 N	0101 N	0102 N	0103 R					
006	ForestFlatW-PnCrkStores	0153 R	0154 N	0101 N	0102 N	0103 N	0104 R				
007	ForestFlatW-Maintenance	0153 R	0154 N	0101 N	0102 N	0103 N	0104 N	0105 N	0106 R		
008	ForestFlatW-ForestFlatE	0153 R	0154 N	0101 N	0102 N	0103 N	0104 N	0105 R			
009	SilvrPass-HiPeak-viaPnCrk	0153 N	0154 N	0101 N	0102 N	0103 N	0104 N	0105 N	0106 N	0107 R	0152 R
010											
011	SilvrPass-Thru-GregSilver	0141 R	0151 N	> 016							
012	GregsonSilver-Siding #1	0141 N	0142 R	0143 R	0144 N	0151 R					
013	GregsonSilver-Siding #2	0141 N	0142 N	0143 N	0144 N	0151 R					
014	GregsonSilver-Siding #3	0141 N	0142 R	0143 R	0144 R	0151 N					
015											
016	Main-HighPeak-Thru	0131 N	0132 N	> 019							
017	Main-HighPeak-Passing	0131 R	0132 R								
018											
019	ForestFlat-Main-Thru	0201 N	0202 N	0203 N	0204 N	> 008					
020	ForestFlat-MainPassing	0201 R	0202 N	0203 N	0204 R						
021											

Clicking **Run Sel Macros**, (or pressing **Ctrl-R**), will first execute Macro 000, followed by the linked Macro 011, and then continue by following the links to run Macro 016,

Macro 019, and finally Macro 008. Execution then continues by running the next selected Macro, ie. Macro 001.

However, note that Macro 001 is linked to Macro 019, and that this Macro has already been executed in the previous sequence. A-Track recognises that this could potentially lead to an infinite loop, with a repeated sequence of turnout (Accessory) commands being output continuously to the Command Station. A warning message to this effect is displayed –

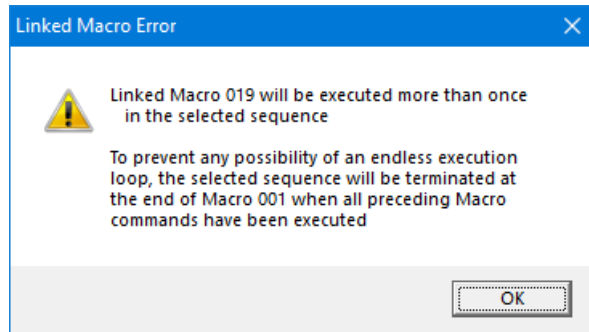

Click **OK** to remove the message from the screen. All commands generated by the Macro 000 sequence will be output, followed by the 7 commands in Macro 001. At this point execution will be halted, without following the link to Macro 019. If any other Macros beyond Macro 001 had been selected, then they would not be executed at all as part of this Run operation.

In this particular case, running Macro 019 again would not actually result in an endless loop, since the repetition is due to multiple Macro selection rather than the incorrect linking of Macros. However, A-Track always errs on the side of caution, just in case you have neglected to check for such a linking loop when creating the Macros (by using the **Go To Linked** function as explained in **Section 7.9**).

You could, of course, completely avoid the potential problem of infinite linked loops, by omitting links from all of your defined Macros, and then manually selecting the sequence of Macros to run, as shown below –

Mac	Description	1	2	3	4	5	6	7	8	9	10	▲
000	Main-SilverPass-HighPeak	0152 N	0107 N									
001	Main-ForFlat-thruPineCrk	0153 R	0154 N	0101 N	0102 N	0103 N	0104 N	0105 R				
002	ForestFlatW-FinePine #2	0153 R	0154 N	0101 R	0108 N	0121 N						
003	ForestFlatW-FinePine #1	0153 R	0154 R	0108 N	0121 N							
004	ForestFlatW-HeathSaw #3	0153 R	0154 N	0101 N	0102 R	0122 R						
005	ForestFlatW-HeathSaw #4	0153 R	0154 N	0101 N	0102 N	0103 R						
006	ForestFlatW-PnCrkStores	0153 R	0154 N	0101 N	0102 N	0103 N	0104 R					
007	ForestFlatW-Maintenance	0153 R	0154 N	0101 N	0102 N	0103 N	0104 N	0105 N	0106 R			
008	ForestFlatW-ForestFlatE	0153 R	0154 N	0101 N	0102 N	0103 N	0104 N	0105 R				
009	SlvrPass-HiPeak-viaPnCrk	0153 N	0154 N	0101 N	0102 N	0103 N	0104 N	0105 N	0106 N	0107 R	0152 R	
010												
011	SlvrPass-Thru-GregSilver	0141 R	0151 N									
012	GregsonSilver-Siding #1	0141 N	0142 R	0143 R	0144 N	0151 R						
013	GregsonSilver-Siding #2	0141 N	0142 N	0143 N	0144 N	0151 R						
014	GregsonSilver-Siding #3	0141 N	0142 R	0143 R	0144 R	0151 N						
015												
016	Main-HighPeak-Thru	0131 N	0132 N									
017	Main-HighPeak-Passing	0131 R	0132 R									
018												
019	ForestFlat-Main-Thru	0201 N	0202 N	0203 N	0204 N							
020	ForestFlat-MainPassing	0201 R	0202 N	0203 N	0204 R							

This, of course, needs more effort to set up, requiring selection of six Macros rather than two. In practice, a combination of linking and multiple Macro selection will probably produce the most workable solution.

If you are using an NCE Power Pro or NCE Power Cab Version 1.65 (including Smart Booster and DCC Twin) system, Macros stored within the Command Station memory can also be run under the control of A-Track, once a copy of them has been loaded into the Route Macro Table. With an older NCE Power Cab Version 1.28 system, internally-stored Macros are not accessible to A-Track, and so cannot be run from the computer screen.

The advantage in running Macros stored within an NCE Command Station is that the operation takes less time, since only a single command has to be sent to the Command Station to execute each Macro. When running Macros from a loaded file, a separate command has to be sent for each Accessory entry in each Macro. The difference in time is only a second or two per Macro, so is not usually significant in model railroad operations.

If you wish to run one or more Macros which have been loaded previously to a suitable NCE Command Station, you can download the relevant Macros into the Route Macro Table (but without any Descriptions) by clicking on the appropriate option in the **Select Macro Set** area, and then on the **Retrieve Set** button.

Alternatively, if the Macros you wish to use are in a saved Route List or Macro Backup file, load the file into the Route Macro Table (complete with Descriptions, if you have added them) by clicking the **Load File** button and selecting the relevant file in the standard dialog, as described in **Section 7.7**. Transfer either a complete Set of 64 Macros to an NCE Power Pro Command Station by clicking on the appropriate option in the **Select Macro Set** area, if necessary, and then on the **Update Set** button, or a selected group of 16 Macros to an NCE Power Cab or Smart Booster Version 1.65, or DCC Twin, Command Station. See **Section 7.8** for full details.

With an NCE Power Pro system, A-Track will run Macros from the Command Station if the relevant Set of Macros have been either Retrieved (downloaded) or Updated (uploaded) since the Macros in the Command Station are guaranteed to be the same as those in the Route Macro Table. However, in the case of NCE Power Cab, Smart Booster, or DCC Twin systems, Macros will only be run for the Command Station if they have been Retrieved (downloaded), since any group of 16 Macros can be uploaded to the Command Station, and there is no way to guarantee that Macros 000 – 015 in the Route Macro Table are the same as those currently held in the Command Station.

Assuming that the Route Macro Table has been set up appropriately, click anywhere on the first Macro you wish to run so that it is highlighted in the Macro Grid, then use the mouse and either **Ctrl** key to add further Macros to the selection, if required, as explained in **Section 7.10**. With an NCE Power Pro system you can select any Macro from any Retrieved or Updated Macro Set, while with any of the NCE Power Cab Version 1.65 systems you can select from Macros 000 to 015 (any selected Macro outside this range will have its constituent Accessory commands output individually by A=Track).

Using the set of linked Macros which were used in the earlier example presented above, and which are now loaded to or retrieved from the Command Station, clicking the **Run Sel Macros** button after selecting Macros 000 and 001, will result in Entry 1

of each Macro being marked briefly with an **orange** highlight, as each 'Run Macro' command is output to the NCE system by A-Track –

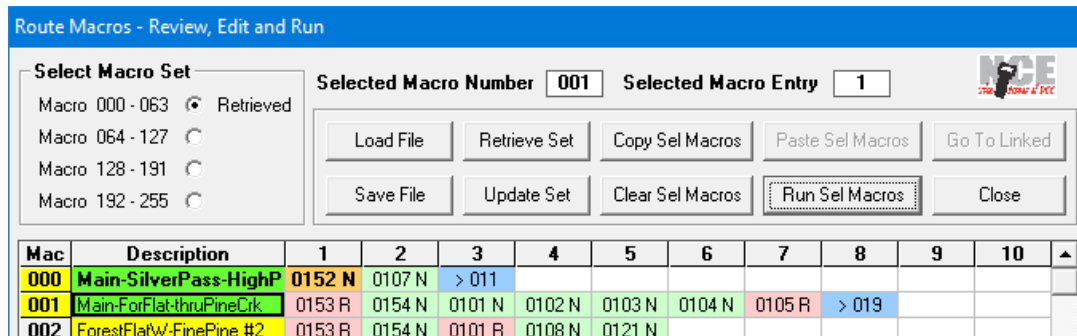

Only a single command is sent to the Command Station to execute all of the Accessory commands contained in Macro 000, together with all those in all linked Macros (Macros 011, 016, 019, and 008 in this case), but you will not get any further indication in the Route Macro Table that the turnout (Accessory) commands are being output by the Command Station – although you should be able to observe the movement of the relevant turnouts on your layout.

Similarly, a single command will run Macro 001, as well as Macros 019 and 008 once again. In this mode of operation there is no indication that Macros are going to be executed multiple times, and it is your responsibility to ensure that the selected Macros are not linked in a continuous (infinite) loop.

If you have made any changes to a Macro Set retrieved from the NCE Command Station, and then choose to run one or more of the displayed Macros before updating the Macro Set in the Command Station, you will see the following warning prompt –

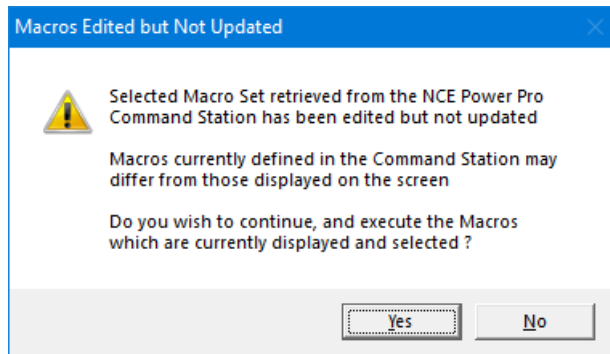

Click **Yes** to continue, and run the selected (and possibly edited) Macros, or **No** to abandon the operation.

Assuming you choose **Yes** to continue, the selected Macro(s) will be executed by sending individual Accessory commands from the Macro(s) rather than by requesting execution from the Command Station memory. Otherwise, you have the opportunity to update the Command Station, by clicking the **Update Set** button, before continuing with Macro execution.

8 LAYOUT MIMIC DIAGRAMS AND TURNOUT CONTROL

While the use of pre-defined Macros, as described in **Sections 7.6 to 7.11** simplifies the selection of specific groups of turnout in order to set routes on your layout for any desired set of operations, anytime you need to set a slightly different route you will need to know the location of the relevant turnouts and their accessory addresses.

To help you find these turnouts as easily as possible, A-Track gives you the facility to construct an on-screen graphical view of all your layout turnouts, in the form of Mimic diagrams, such as that shown in the two example panels below –

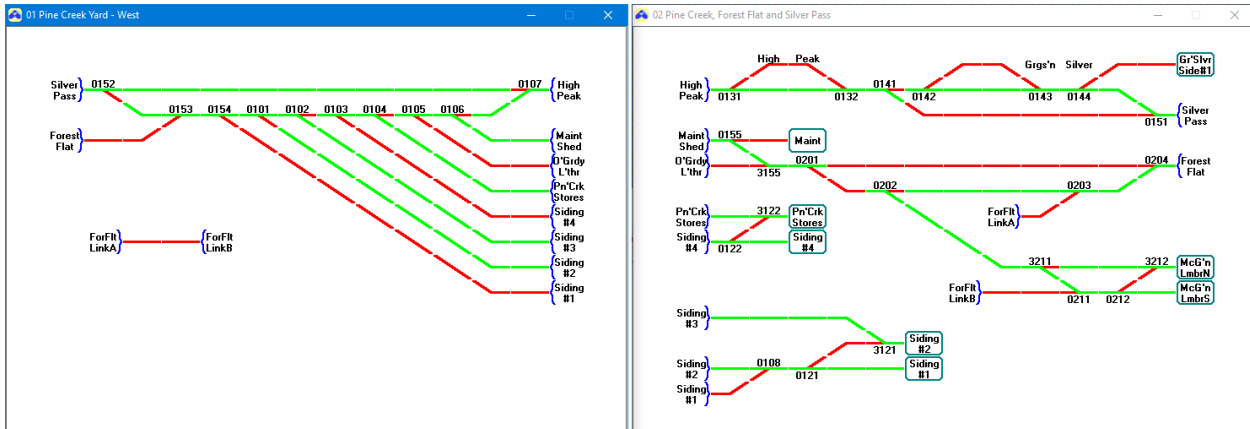

From these Mimics you can control the setting of any turnout via the click of a mouse, with the commanded position shown immediately on the screen display.

However, rather than set each turnout individually for a specific route, A-Track also provides the facility to select the start and end points of a required route (plus an optional mid-point). A-Track will then figure out the necessary intermediate turnout settings automatically. All turnouts making up the found route can then be switched to their appropriate positions with a single click.

If this selection is likely to be a frequently-used route, the turnout settings for the route can be saved as an NCE System Macro, although, in most cases, setting the route from a Mimic each time it is required will be just as quick as selecting and executing a pre-defined Macro.

8.1 Constructing, Saving and Loading Mimic Diagrams















The A-Track Mimic diagram facility allows you to represent the functionality of your layout within a set of up to 32 Mimic panels. Each Mimic panel contains a 16 x 16 grid in which you can place individual layout elements. Each element can be either a turnout, a piece of interconnecting track, a terminal point, a descriptive label, or a link to or from another Mimic panel.

When transferring your layout to a set of Mimic panels, it is important to note two key points –

1. The Mimic diagrams show only how elements are connected to each other without any regard for the distances between elements
2. Elements can only be connected left to right, or right to left (conventionally, in an East-West direction) – no connections are allowed via the top or bottom edges of

a Mimic panel (North-South) – “straightening out” complex layouts to fit this constraint, particularly where they contain reversing loops or wyes, may need a little thought (or be drawn in a specific way), but is always possible

The 15 types of element you can use in constructing a set of Mimic panels (Mimics) to represent your layout are shown, with their names, in the table below –

			
Blank (Label)	Track CL-CR	Track CL-TR	Track TL-CR
			
Track CL-BR	Track BL-CR	Track TL-BR	Track BL-TR
			
Turnout CL-TR	Turnout TL-CR	Turnout CL-BR	Turnout BL-CR
			
Link CR	Link CL	Terminal	

– where TL = Top-Left TR = Top-Right
 CL = Centre-Left CR = Centre-Right
 BL = Bottom-Left BR = Bottom-Right

Before attempting to construct your own set of Mimics, ensure that A-Track is **not connected** to an NCE Command Station. Since Mimics can actively control turnouts on your layout, creation or editing of any Mimic panel is only enabled when there is no active connection to the layout. Assuming that your Command Station is disconnected or switched off, open the **Mimic** menu and click on the **New Mimic** option –

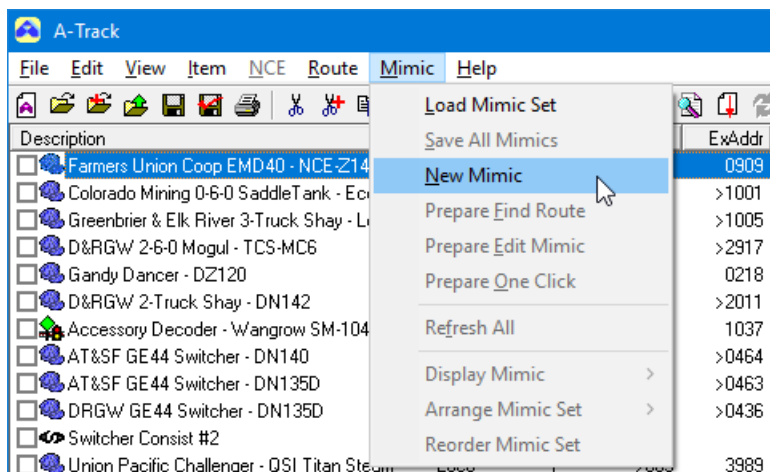

This will open a blank Mimic panel showing a 16 x 16 grid –

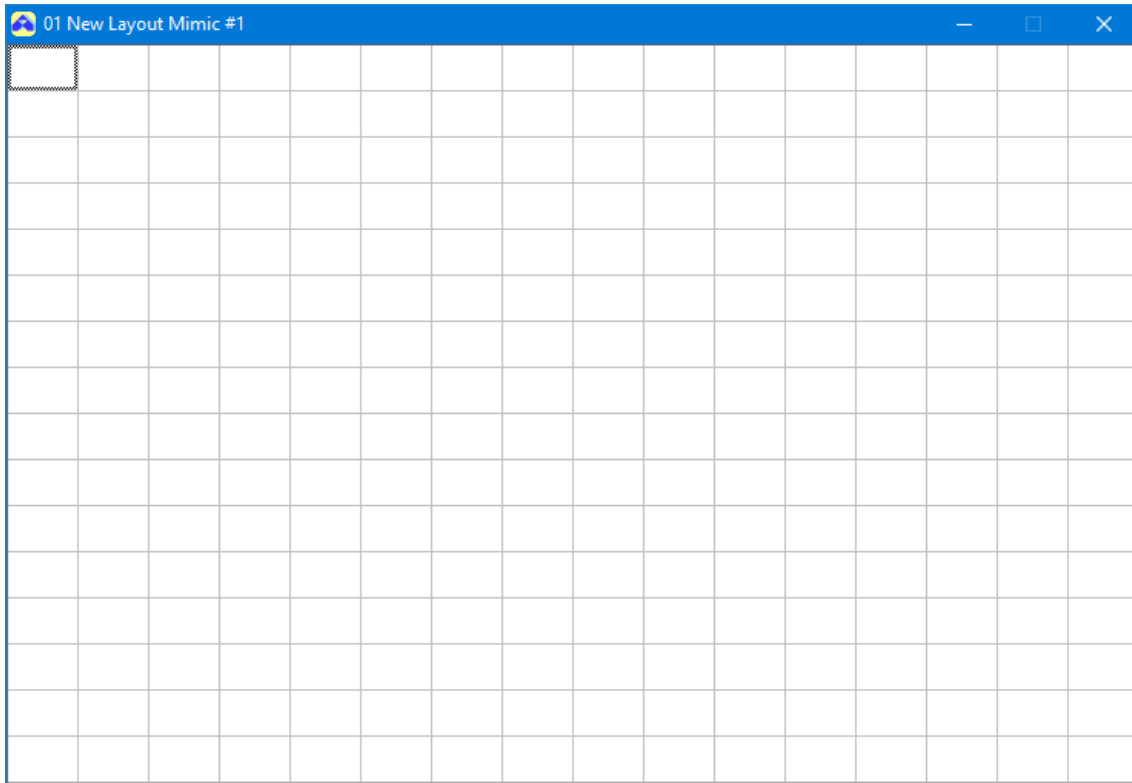

The panel title bar displays first of all the panel number (**01**), followed by the panel title (**New Layout Mimic #1**) which you can change to a more meaningful title of your own for this particular panel, as part of defining the Mimic contents.

To change the content of any of the Mimic grid cells, or any other feature of the Mimic, right-click in any chosen cell to display an edit window –

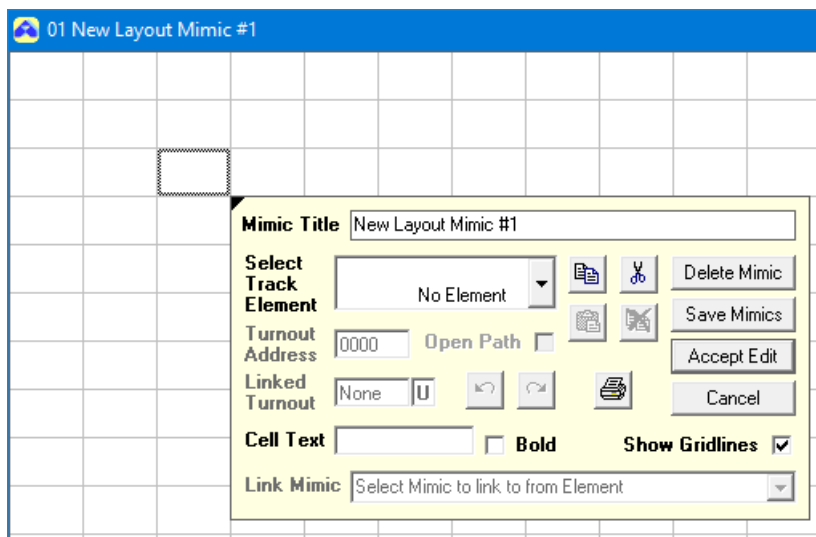

Note the small black triangle (▴) in the top left corner of the edit window. This points to the Mimic cell which is being edited, and a similar marker will appear in whichever corner of the edit window is nearest to the relevant cell.

In order to define the content of any Mimic panel, we first need to have a layout to represent, so an example layout is shown below (parts of which have been used as examples in previous Sections) with the turnout addresses shown in **blue** –

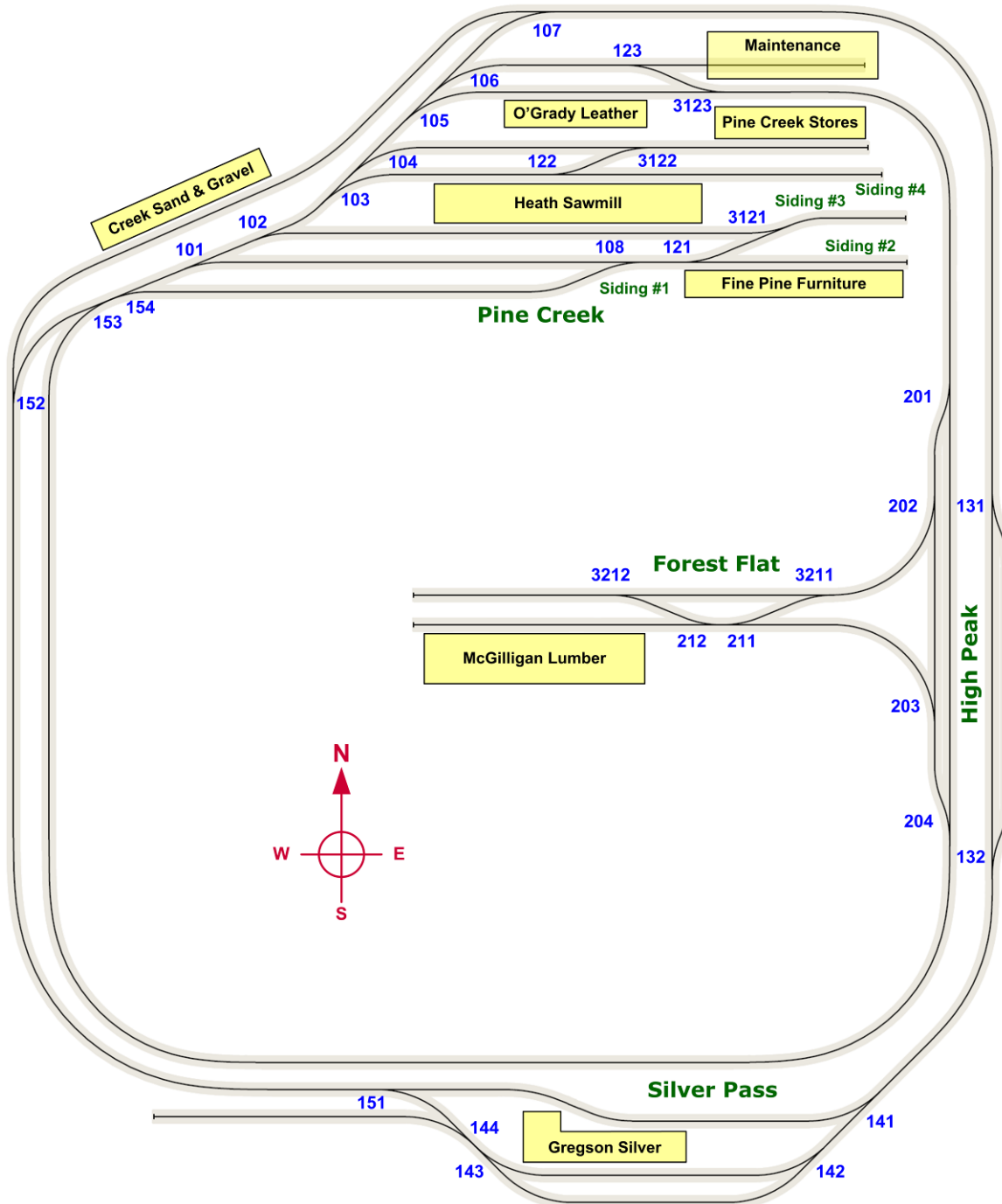

We can make a start on our Mimic construction with the Pine Creek Yard at the North end of the layout. Note, however, that with a total of 17 turnouts associated with this part of the layout, it may not fit within a single Mimic panel.

Returning to the Mimic panel and its edit window, the first step is to give this panel a name by typing it into the **Mimic Title** textbox ('Pine Creek Yard'). Next, select a first track element to place in the selected cell by clicking on the small down arrow to the right of the **Select Track Element** combobox, then scrolling down to find a suitable Turnout element for our first turnout (0152) –

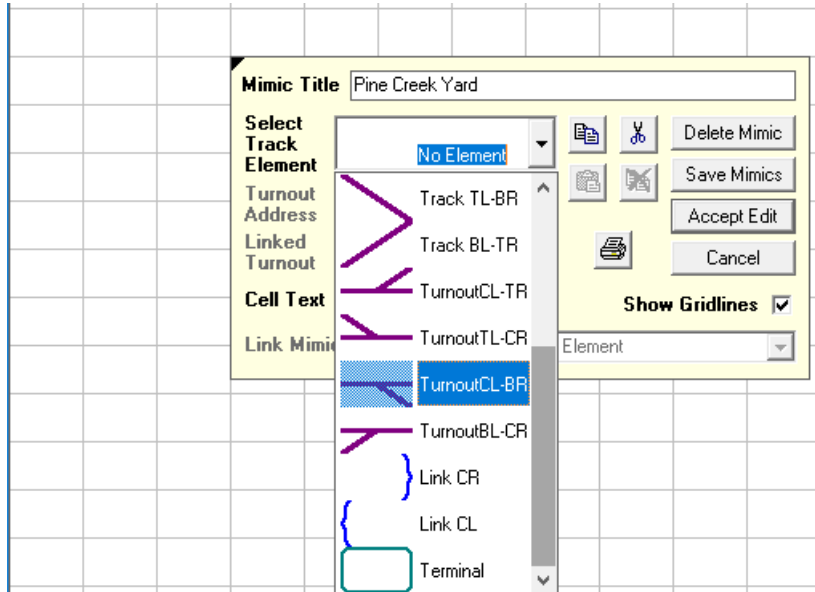

Click to confirm the choice of the selected Turnout element, and then type the address of the turnout '152' into the **Turnout Address** textbox, which has now been enabled –

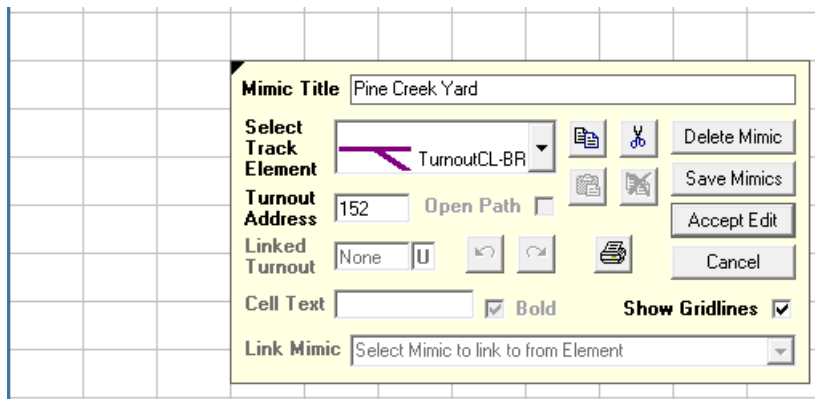

Click **Accept Edit** to transfer the turnout, labelled with its address, to the previously-chosen grid cell of the Mimic –

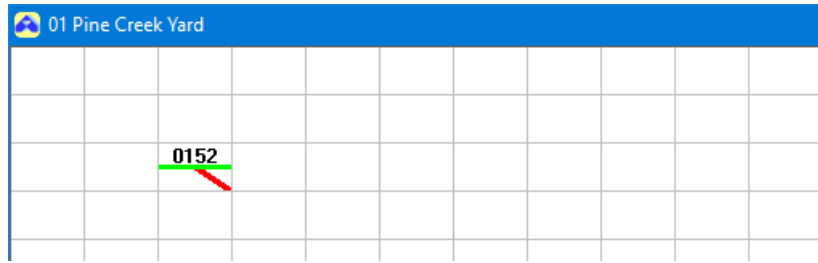

Since the Accessory hosting turnout 0152 (Pine Creek West – Lenz LS150) is in the Item List, with the turnout status (0) in the rightmost column indicating that it is set in the Normal direction –

<input type="checkbox"/>	Silver Pass - DCC-Concepts - Cobalt AD4	Access'y	_P_	0036	>0143	0000
<input type="checkbox"/>	Pine Creek West - Lenz LS150	Access'y	_P_	0038	>0151	103056
<input type="checkbox"/>	Forest Flat - Tam Valley Quad-PIC	Access'y	_P_	0051	>0201	0200
<input type="checkbox"/>	McGilligan Lumber #1 - NCE Switch-It	Access'y	_P_	0053	>0212	00
<input type="checkbox"/>	McGilligan Lumber #2 - NCE Switch-It Mk2	Access'y	_P_	0056	>0221	00
<input type="checkbox"/>	Forest Flat & McGilligan Lumber	Access'y	_P_	0051	>0201	02300000

Item List : C:\Users\User\Documents\A-T ... Lists\AT-Tutorial-Demo-44+SuperAccsy.itl | Items : 28 | Current : 24 | NCE CDM

– it is displayed as active in the Mimic grid cell, with the main straight (Normal) track shown in **green**, and the diverging (Route) track shown in **red**.

If you double-click on the turnout in the Mimic cell, its commanded status will change to Route with the diverging track now shown in **green**, and the main straight track in **red**. If the Command Station was active at this time, A-Track would generate an Accessory command to set the relevant decoder Output to the Route direction but will, in all cases, update the Item status to reflect the turnout direction, as shown below –

---	>0143	0000
0038	>0151	123056
0051	>0201	0200
0053	>0212	00
0056	>0221	00
0051	>0201	02300000

4+SuperAccsy.itl | Items : 28 | Current : 24 | NCE CDM

Returning to the construction of the Mimic panel, we can add track connections for the Creek Sand & Gravel bypass and for turnouts 0153 and 0154 by a right-click in the appropriate grid cells to open the edit window and select the relevant elements. The result so far is shown below, where turnout 0101 is about to be added –

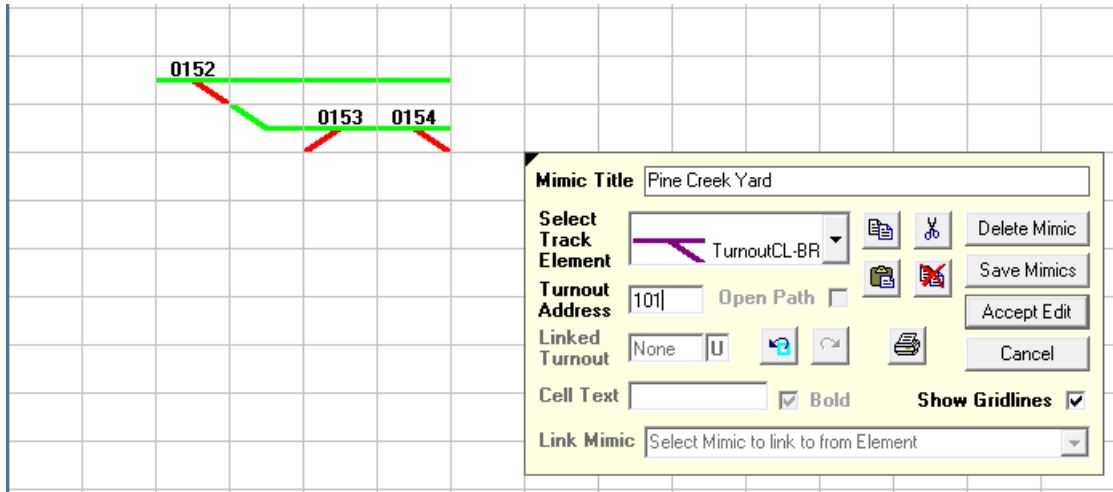

At this stage you should consider saving a copy of your new Mimic just in case anything goes wrong. You can do this from the edit window by clicking on **Save Mimics**, although this action will discard any selection or text edits currently in the edit window before opening the standard Save dialog window. Alternatively, open the Mimic menu from the main A-Track window and select Save All Mimics –

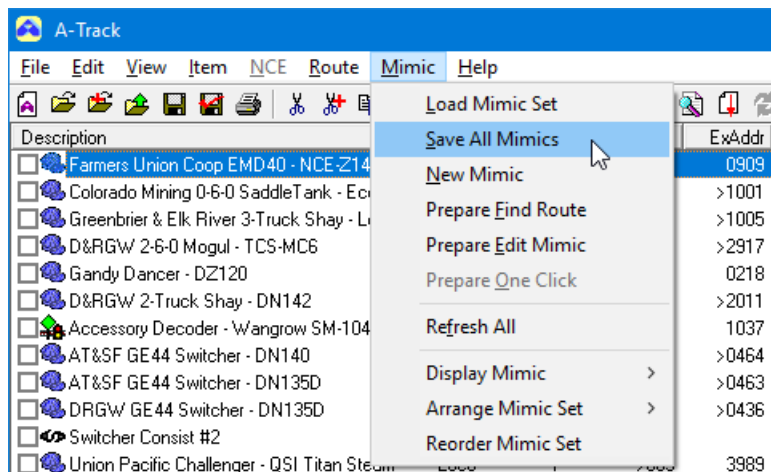

This opens the standard **Save Mimic List** dialog where you should select (or create) a suitable destination folder for the saved file before typing a filename for your new Mimic(s) in the **File name** textbox and clicking the **Save** button –

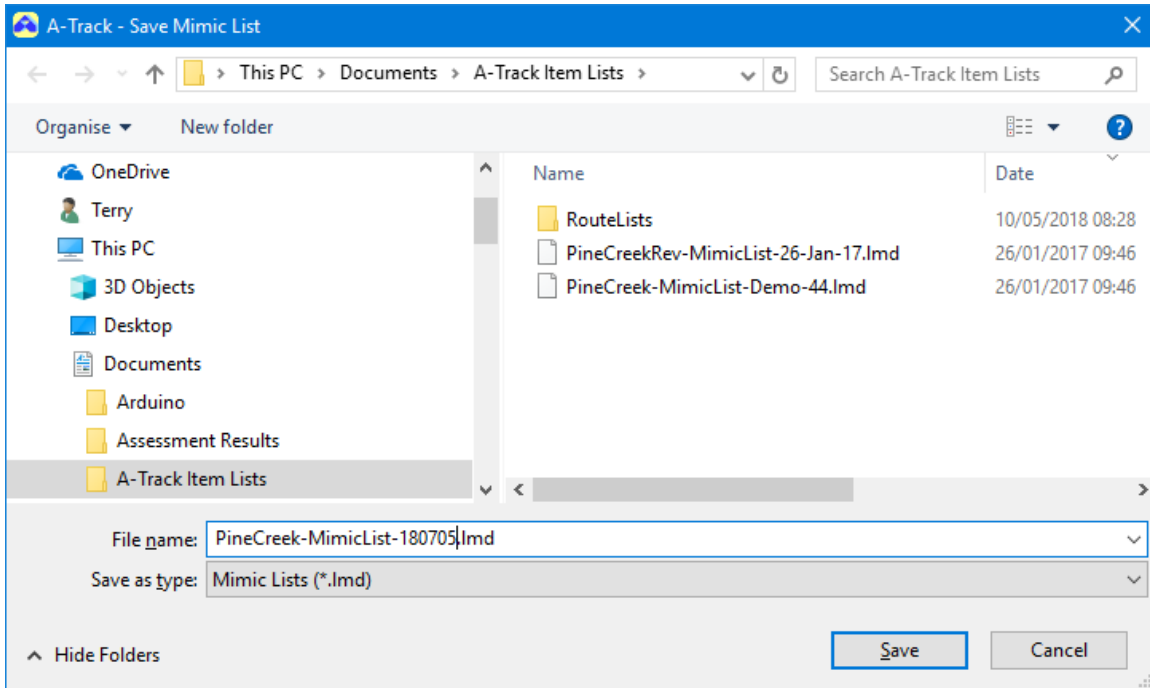

Note that Mimic Lists are saved with the file extension **.lmd** to enable A-Track to recognise such files easily.

When you reload a saved Mimic Set (using the **Load Mimic Set** option on the **Mimic** menu shown above) you may see that the Mimic gridlines are not shown on one or more panels. This will be the normal state when you are using a completed set of Mimics to control your layout turnouts, and occurs when the relevant Mimic panel does not have gridlines displayed at the time the Mimic Set is saved.

While you are in the process of constructing or modifying a Mimic panel, you can display the gridlines on that panel by a right-click in any grid cell to show the edit window, and then clicking to tick the **Show Gridlines** checkbox in the edit window (untick to hide the gridlines), as shown below. Here, the turnout ladder for the Pine Creek Yard has been completed, and details of the sidings are about to be added –

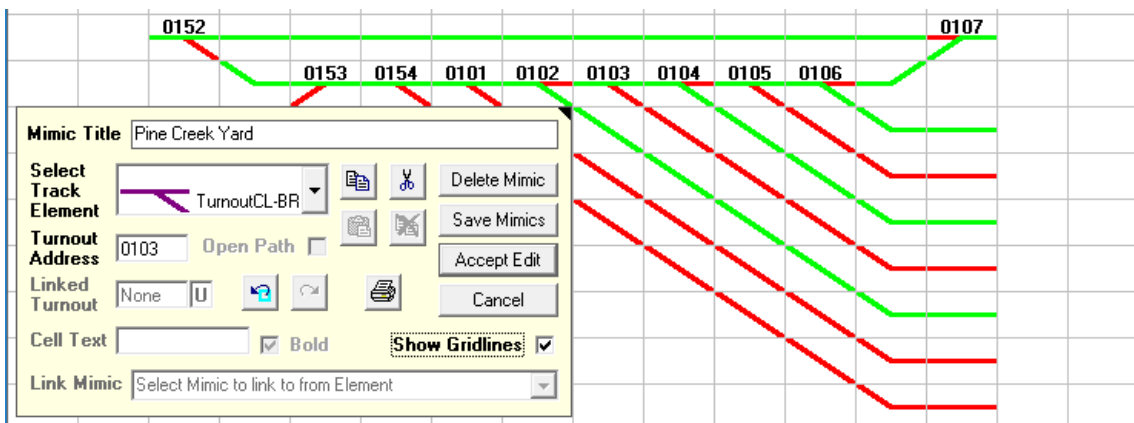

However, as you can see, after adding connecting track elements from all of the turnouts in the yard ladder, it is not possible, within the imposed drawing constraints, to fit the more complex details of the sidings into the panel.

We will, therefore, need to add a second panel to the Mimic Set. However, before doing this (and simply making the screen rather crowded), it is useful to complete the first panel by adding Link elements which will serve to link the two Mimic panels together –

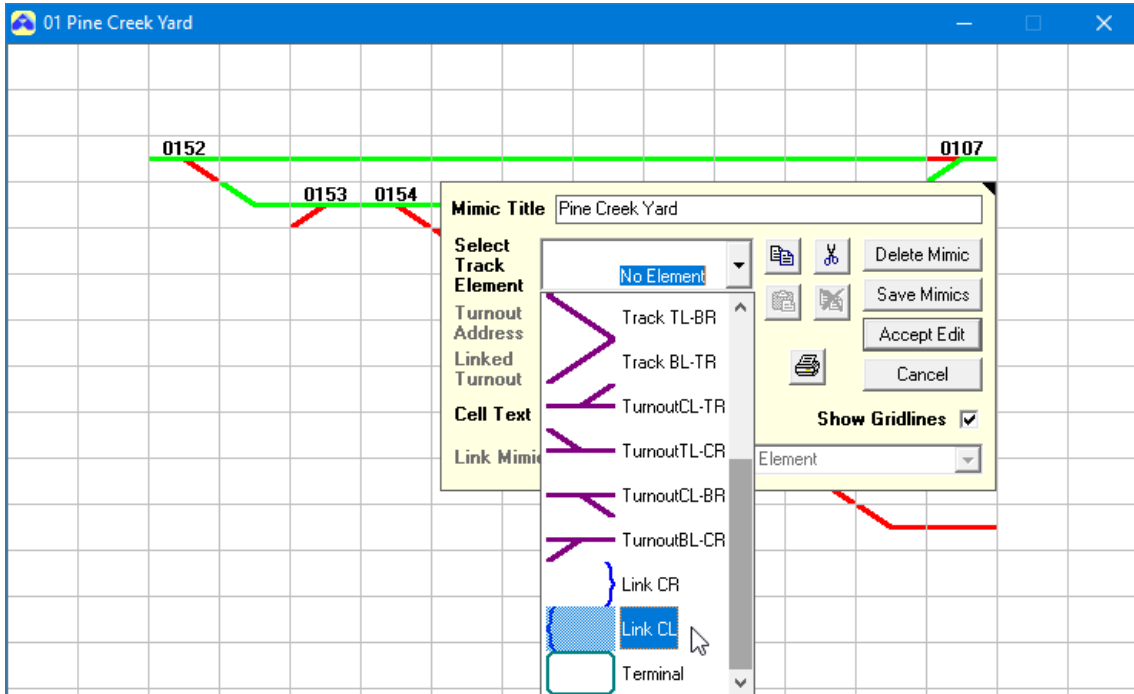

Complete the addition of the first Link by typing a name into the **Cell Text** textbox – names can consist of two groups, each of approximately 6 characters, separated by a space ('High Peak' in this case). For Links, the text is made **bold** automatically. Continue by adding Links to each of the remaining sidings –

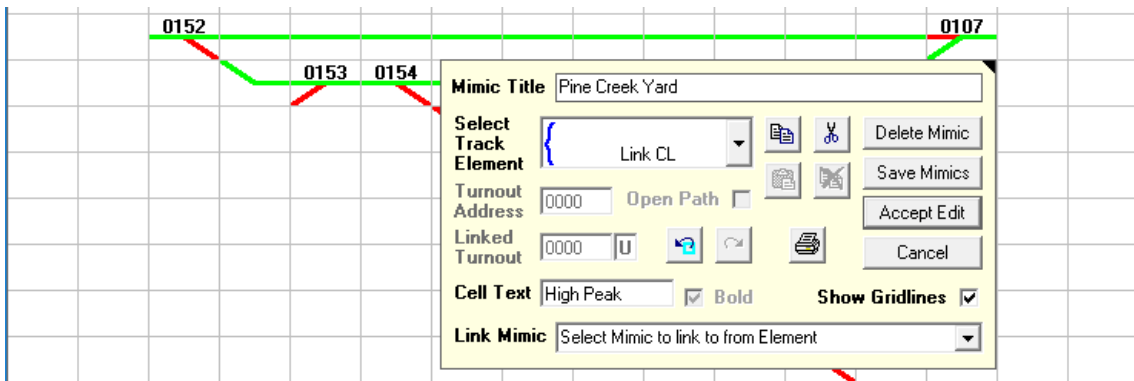

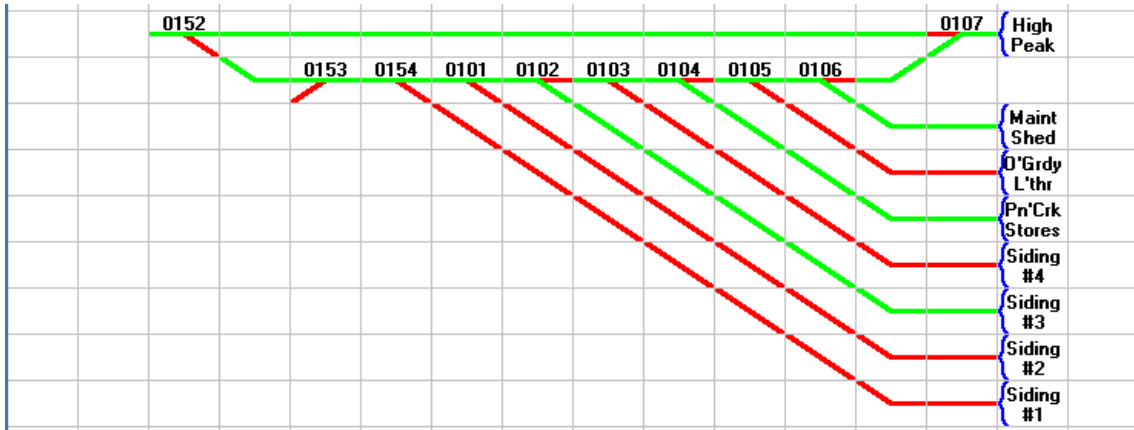

Save your work so far by saving the Mimic Set to file, then add the required second panel by clicking the **New Mimic** option on the **Mimic** menu. Right-click on the new panel to open the edit window and type in a new Mimic Title ('Pine Creek Yard - East') to replace the default caption -

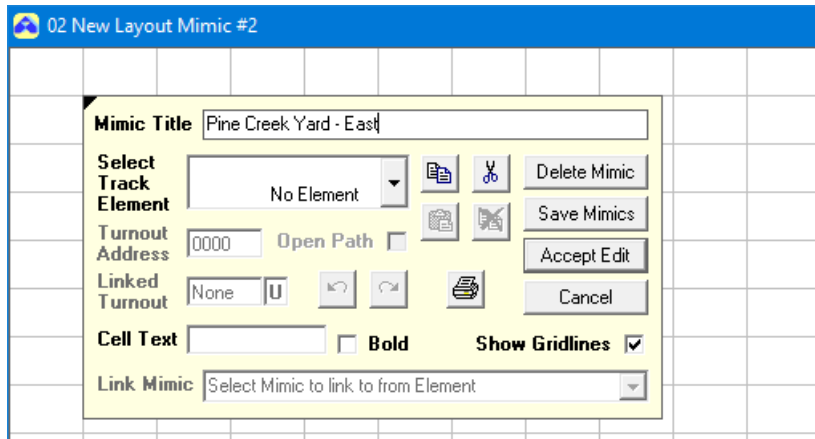

We can now add corresponding Links to the second Mimic panel, ensuring that the name given to each Link is exactly the same as that of the corresponding Link on the first Mimic panel. It is not necessary to align Links in the same row on the second panel as on the first panel, although this does make the connection clearer - and you can achieve this on the screen by dragging the two panel windows apart (click on a Mimic panel title bar, hold down the left mouse button, then move the mouse). As Links are added, the relevant Track and Turnout elements can also be connected -

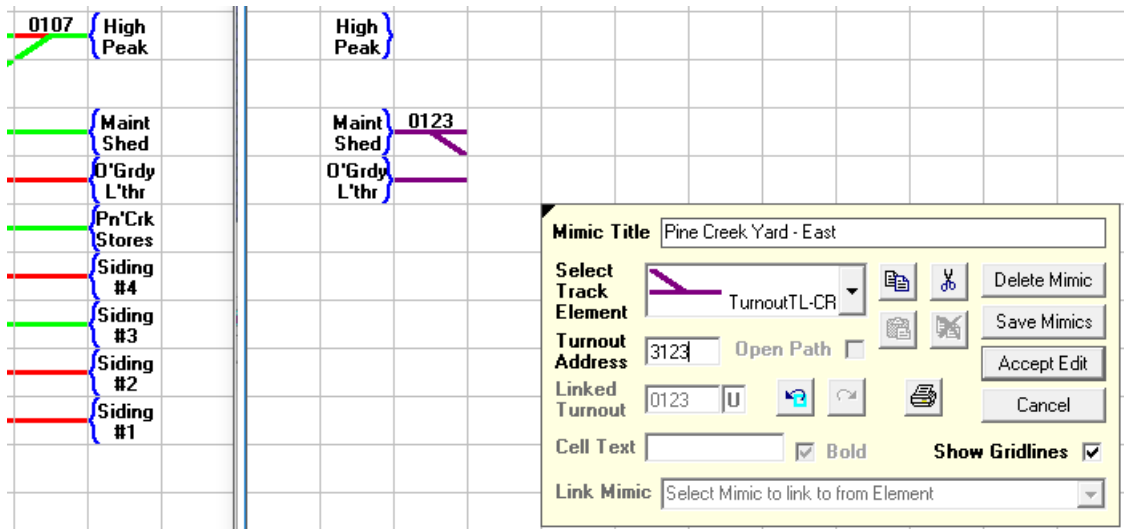

When adding the two linked turnouts leading to 'Maintenance', you can note that, as soon as the address (3123) of the linked turnout is entered to the **Turnout Address** textbox, the corresponding turnout (0123) is recognised as being on the Mimics already, and its address is entered to the **Linked Turnout** textbox.

However, note also that the Turnout element representing turnout 0123 is shown in **purple**, rather than **red** and **green**, which immediately tells you that none of the Accessory Items in the loaded Item List has an Output with address 0123. This may be due to an error in entering the address, or that the relevant Item has not been included in the current Item List. In this case, an available solution is to make use of one of the unused Outputs in Item #24 (Pine Creek West – Lenz LS150), shown as an example in **Section 7.4**. The first step is to reprogram the Item, either by setting Output 5 to address 0123, or (a simpler solution) use the already-programmed address 0155 for our turnouts. Add address 3155 to the **Link** textbox and 'N' to the **Dir** textbox as explained in **Section 7.2**, and then type in 'Maintenance' for the new **Output (Turnout) Name**, as shown below –

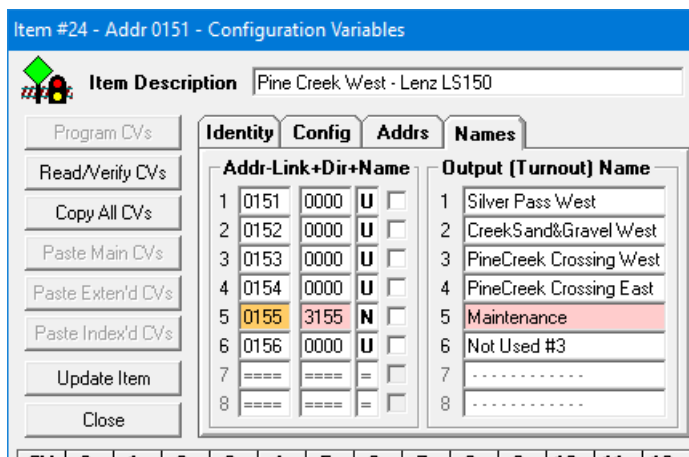

We can also take the opportunity to add an **Output (Turnout) Name** for the linked turnout (3155) by ticking the **Name** checkbox and typing 'O'GradyLthr – ForestFlat' into the textbox (only 24 characters allowed), as shown below –

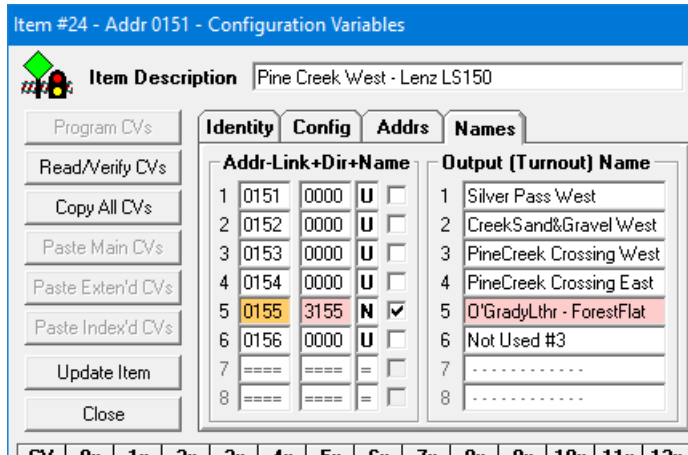

Click **Update Item** to save the edited details back to the Item List, then return to Mimic 02 (Pine Creek Yard – East). Right-click on turnout 0123 and change its address by typing '155' into the **Turnout Address** textbox followed by a click on **Accept Edit**. Do the same for turnout 3123, as shown below, noting that the **Linked Turnout** textbox now shows a confirmed link to turnout 0155, –

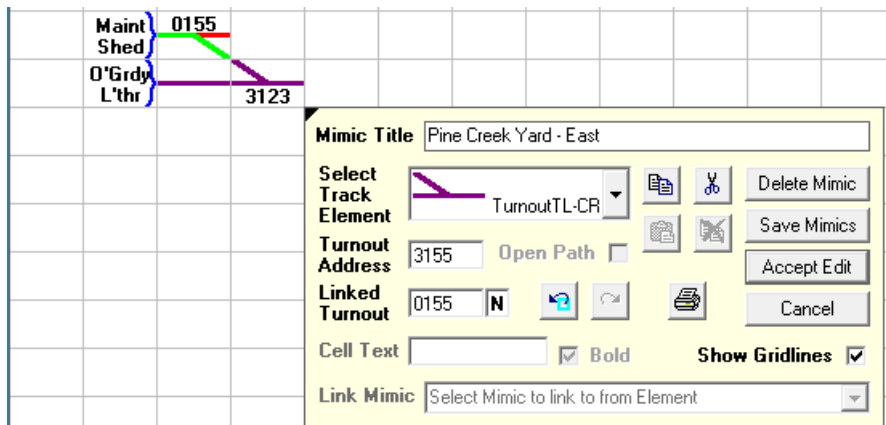

Clicking **Accept Edit** then gives the expected result, with both turnouts now displayed in **green and red**, rather than **purple** –

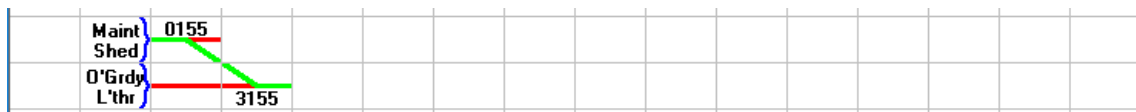

As discussed in **Section 7.2**, turnouts 0155 and 3155 are driven from the same Accessory Output, and set so that both operate in the same direction (operation set to Normal – N) when an Accessory command is sent to address 0155 (as, for example when *either* of the turnouts on the Mimic above are double-clicked).

Having changed the turnout addresses from those used originally, it might be useful at this point to amend any other layout documentation with the changes –

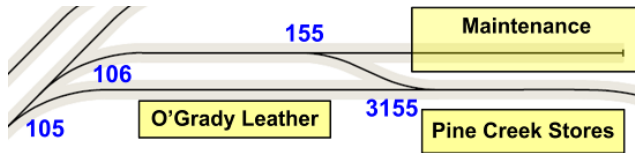

With all of the details of the Pine Creek Yard Sidings added, the second Mimic panel develops as shown below, with three linked pairs of turnouts –

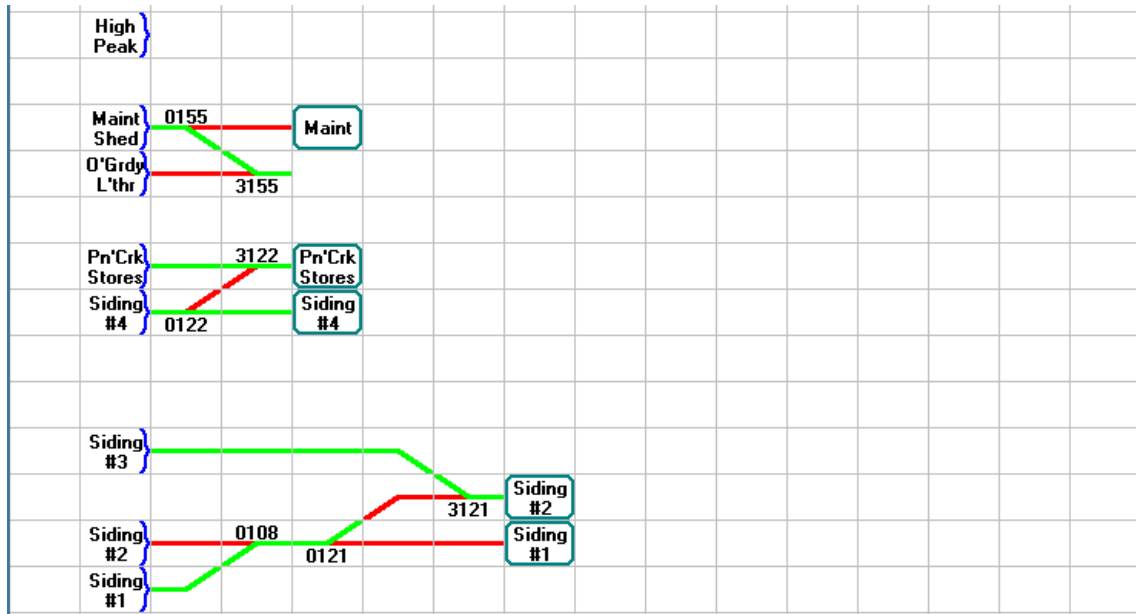

Note, however, that the linked (same-address) pair 0121 and 3121 have been set incorrectly in Normal rather than Reverse mode (see **Section 7.2**) so that they switch in the same, rather than opposite, directions when operated. Fixing this is easily accomplished by editing the Accessory Item handling turnout 0121, which currently shows turnout 0121 linked in the Normal mode to turnout 3121 –

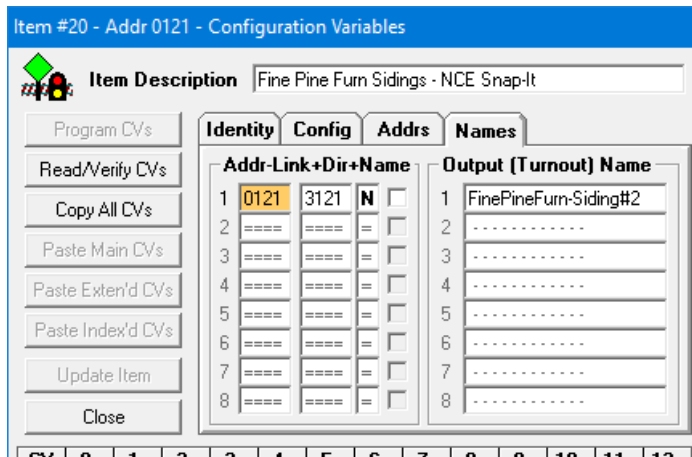

Click in the **Dir** textbox and replace 'N' with 'R', then press the **Tab** (⇧) key to highlight the **Output (Turnout) Name** –

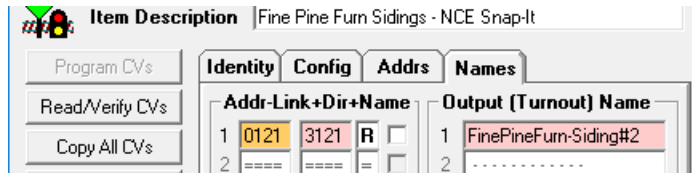

Next, click to tick the **Name** checkbox and display the **Output (Turnout) Name** assigned to the linked turnout, and edit it if necessary. The result should be as shown below (see **Section 7.2** for full details) –

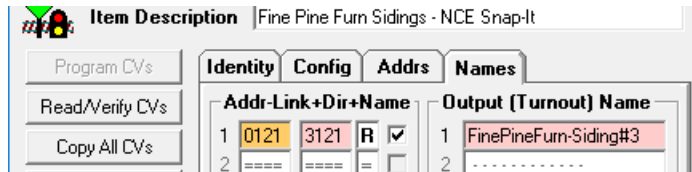

Click **Update Item** to transfer the changes to the Item List, then open the **Mimic** menu and click the **Refresh All** option to update all of the turnout settings within the Mimic Set –

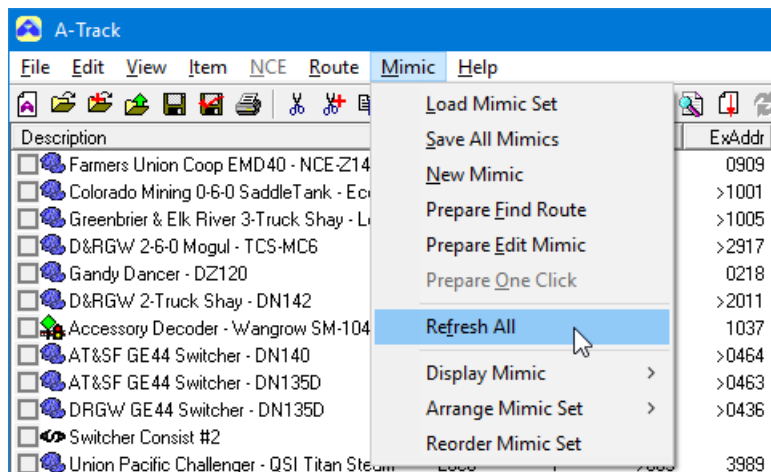

Turnouts 0121 and 3121 should now be linked correctly so that, if either is double-clicked on the Mimic, the other will switch in the opposite direction –

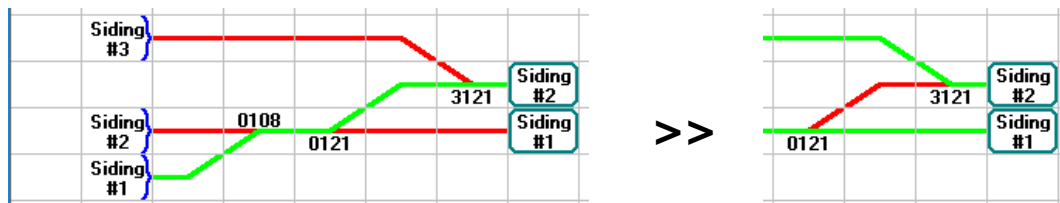

Returning to the Link elements on the two Mimic panels, once they are all in place, a final step is required to complete the links between panels. Right-click on the first Link element on the first Mimic panel to open the edit window, then click to select the second Mimic panel 'Pine Creek Yard – East' from the drop-down list at the bottom of the edit window (click the down-arrow (▼) at the righthand end of the listbox), as shown below. Note that this is also an opportunity to rename the first Mimic panel from

'Pine Creek Yard' to 'Pine Creek Yard - West' as a more descriptive title now that the Yard is spread across two panels -

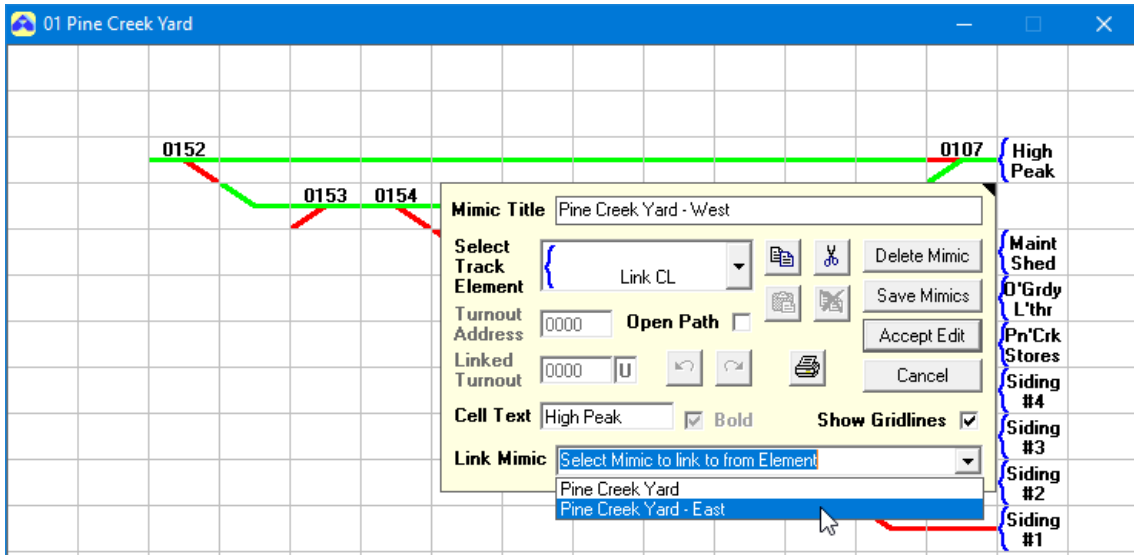

With the **Link Mimic** selected, click **Accept Edit** to confirm the linkage, then repeat for each of the other seven Link elements on this Mimic panel. Go through the same process for the Link elements on the second Mimic panel although, this time, select 'Pine Creek Yard - West' as the **Link Mimic** for all eight Link elements, as in the example shown below -

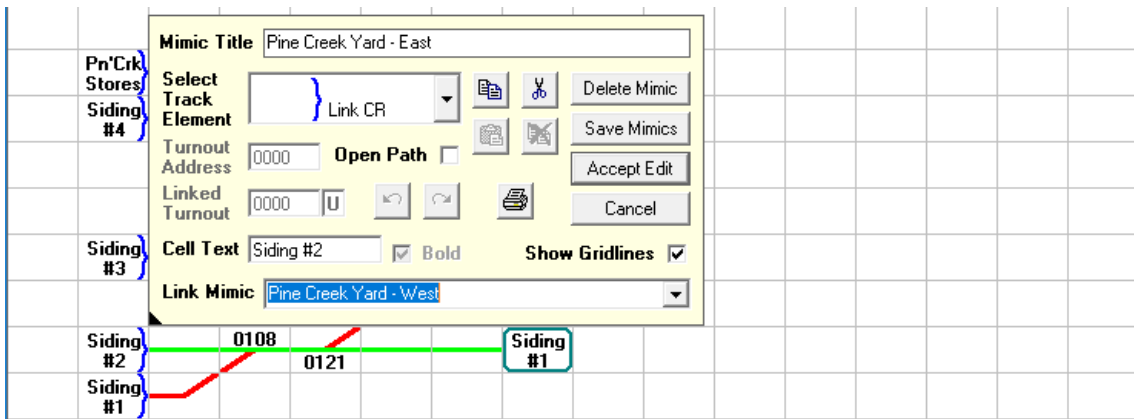

Having reached this stage, it is again a good idea to save a copy of the Mimics drawn so far, by clicking the **Save Mimics** button in the edit window (shown above), or by selecting the **Save All Mimics** option from the **Mimic** menu in the main A-Track window. Since we have also changed the turnout settings in a number of Accessory Items in the course of defining the Mimics, it is also good policy to save a copy of the Item List.

To reload a saved file, open the **Mimic** menu from the main A-Track window and click on the **Load Mimic Set** option to open an Open Mimic List dialog very similar to the Save Mimic List dialog shown earlier in this Section.

Select the required file and click the **Open** button (or simply double-click on the file) to load the Mimic Set.

Rather than display all Mimic panels immediately, a small pop-up menu will appear next to your mouse cursor –

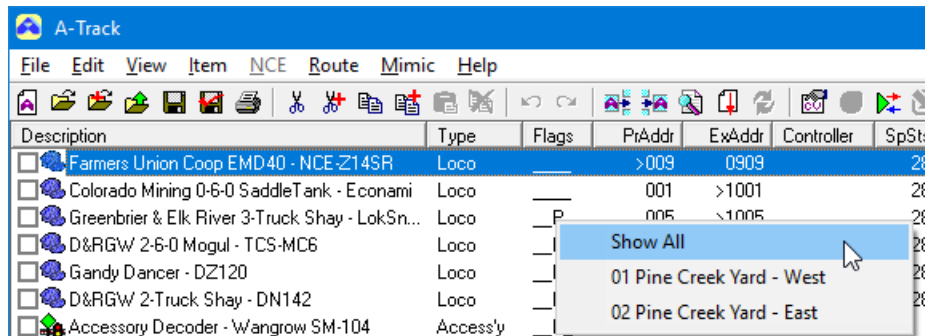

Click **Show All** to display all of the Mimic panels in the Set, or on any other entry to display only that Mimic panel. After the Mimics are displayed, clicking on the **Display Mimic** option on the **Mimic** menu will show a submenu with an option to **Hide All** Mimics (remove them from the screen). Each Mimic panel will also be listed on the submenu with a tick mark next to its title to show that it is currently visible. Clicking on any Mimic title will hide that individual Mimic panel and remove its tick mark –

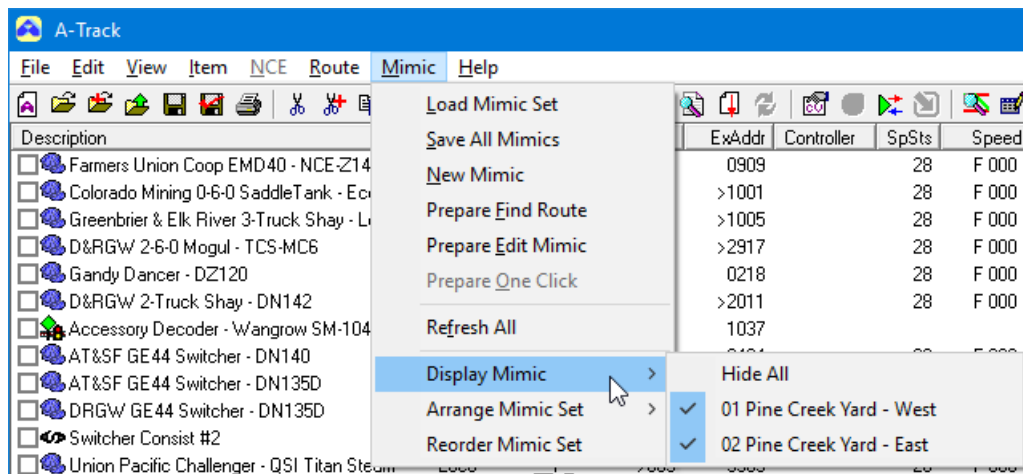

Multiple Mimic panels will initially be shown in a **Cascade** format, where the panels overlap each other, starting near the top lefthand corner of the screen –

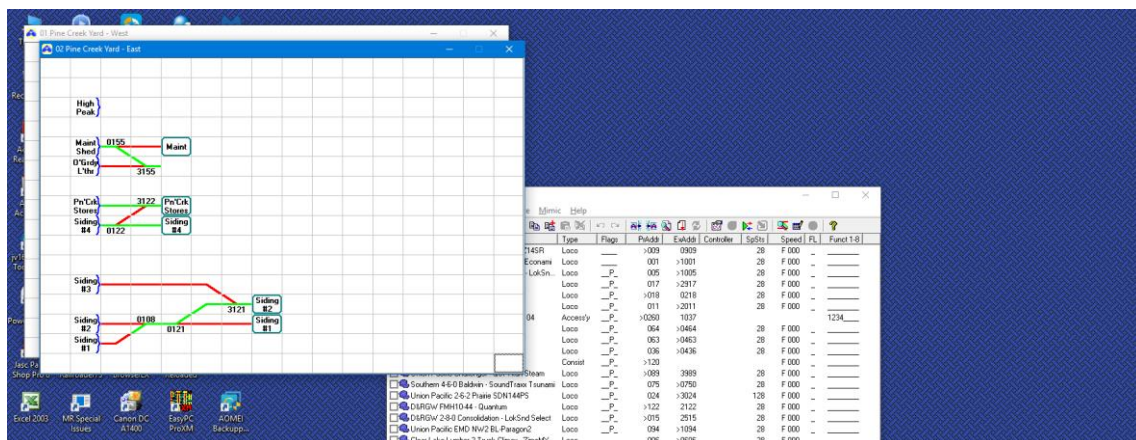

Click on the visible part of any Mimic panel, or on its icon on the taskbar (normally at the bottom of the screen), to bring it to the front of the display so that you can view its details. Alternatively, open the **Mimic** menu and click on the **Arrange Mimic Set** option to display two arrangement options, **Cascade** and **Tile** –

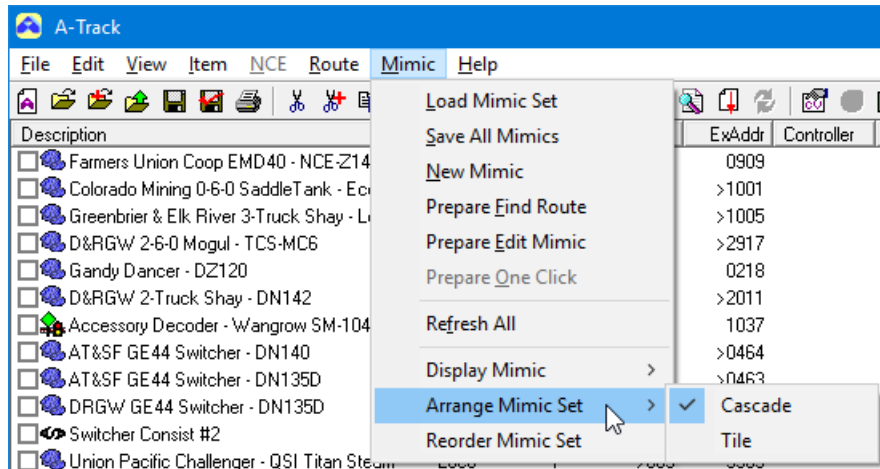

If the PC you are using to run A-Track has a screen with a resolution greater than 1600 x 1024 pixels (1920 x 1080 pixels being the most common size), then clicking the **Tile** option will display the Mimic panels side-by-side, without overlapping, and centred on the screen, for easier viewing –



In **Tile** format, with a large enough screen, you will be able to have four (or more) Mimic panels on the screen at any one time, displayed in numerical order, left-to-right then top-to-bottom.

With more than four panels in the Mimic Set, and one Mimic selected as the active window, press the '**D**' (Down) key on the keyboard to scroll the first two panels upwards, off the screen, and display the next group of up to four panels, starting at Mimic panel #3. Pressing the '**U**' (Up) key will scroll the last pair of panels downwards again, to view the previous group of four.

With smaller screens, the **Tile** option will display only a single Mimic panel at a time, and you can then use the '**D**' and '**U**' keys to scroll through the Mimic Set panels in numerical order.

At any time, you can press the **'C'** key to display the Mimics in **Cascade** format, or the **'T'** key to arrange them in **Tile** format, as a simpler alternative to the use of the **Mimic** menu **Arrange Mimic Set** options.

In both **Cascade** and **Tile** display formats, you can immediately hide all Mimics (remove them from the screen) by pressing the **'H'** key on the keyboard. However, to return all (or a selected set) of the Mimics to the screen again, you will need to use the **Mimic** menu, and click on one of the **Display Mimic** submenu options.

Returning to the construction of the Mimic panels, it is fairly straightforward to add the layout sections comprising the two main loops to the 'Pine Creek Yard – East' panel, namely 'High Peak' through 'Silver Pass', and that via 'Forest Flat' –

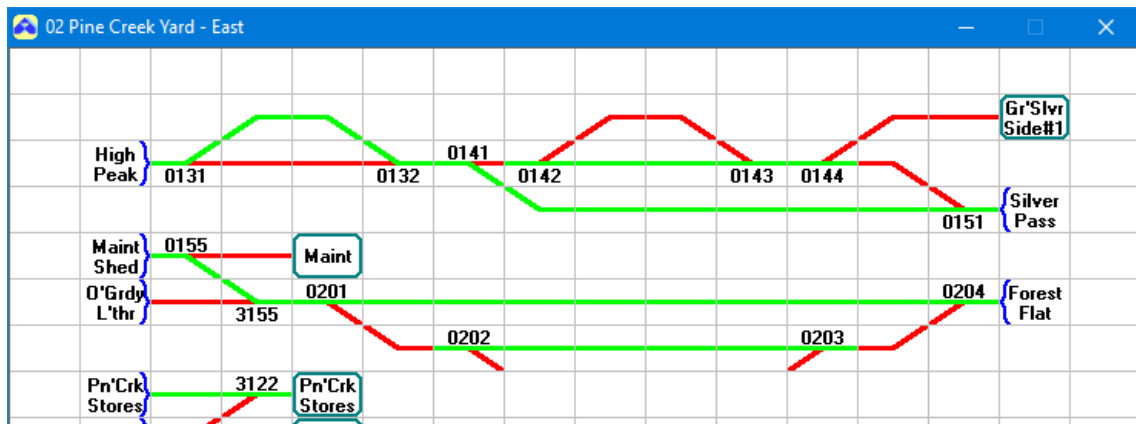

Each section ends in a Link element, named 'Silver Pass' and 'Forest Flat', as shown above, both of which will be linked to the 'Pine Creek Yard – West' Mimic panel. Corresponding Link elements are then added to the appropriate points on the 'Pine Creek Yard – West' panel, linked back to the 'Pine Creek Yard – East' Mimic, as shown below –

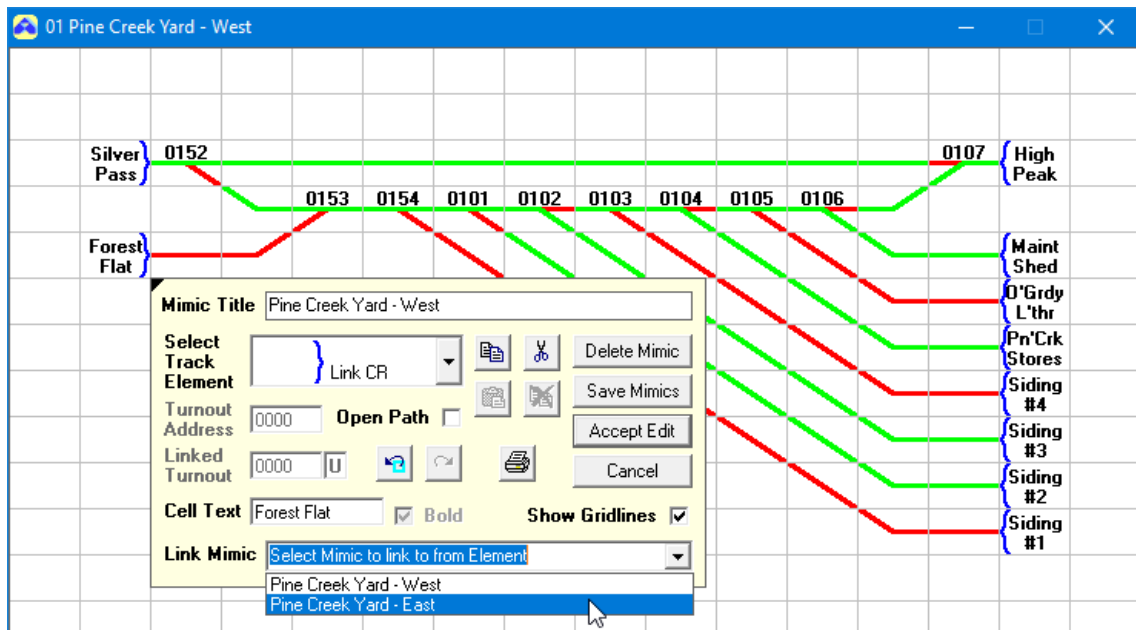

To help identify which parts of a Mimic represent specific places on the real layout, you can add text (consisting of one or two groups, each of approximately 6 characters, separated by a space) to any Track element or to any empty cell, as shown in the examples below, where the 'High Peak' passing siding and the 'Gregson Silver' mine have been (or are in the process of being) appropriately labelled, using the **bold text** option, by clicking to tick the **Bold** checkbox in the edit window -

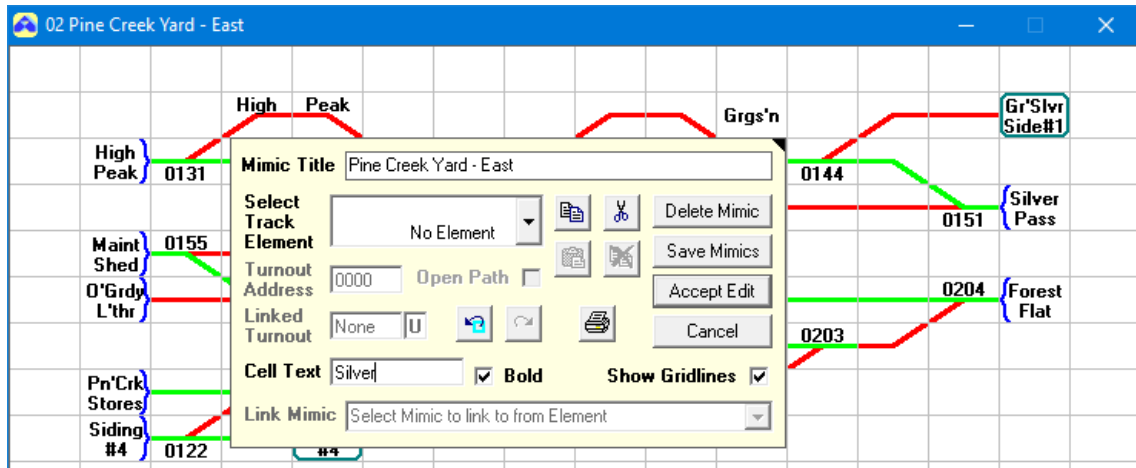

Adding the final layout elements to the Mimics, making up the 'wye' at 'Forest Flat' is a little more complicated because of the drawing limitations imposed by A-Track. We can add the connections to the sidings at 'McGilligan Lumber' easily enough -

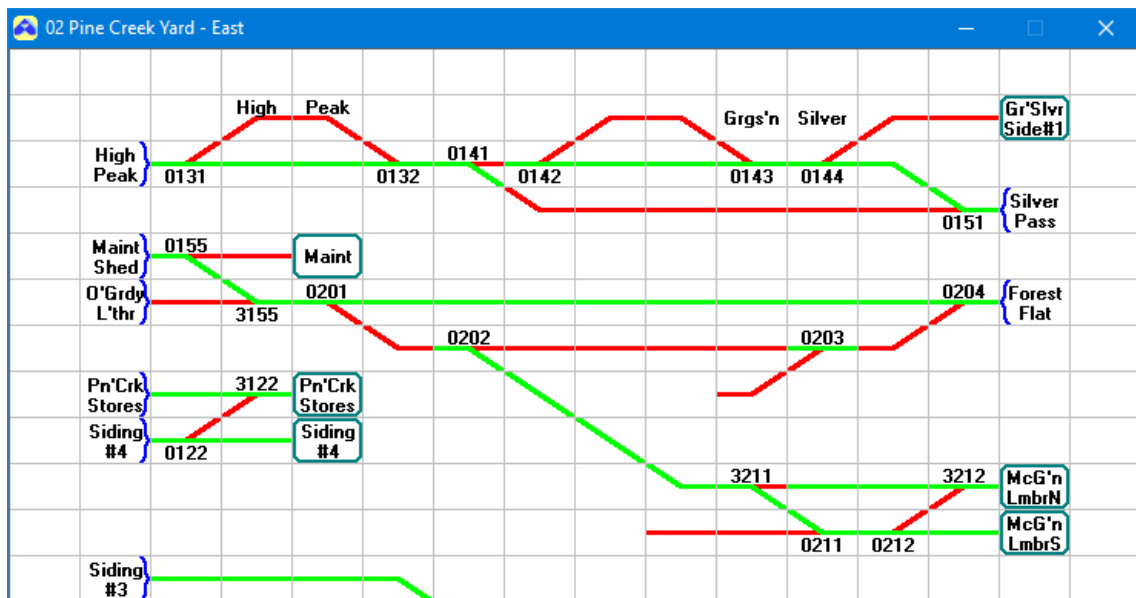

However, the problem then arises of how to connect the track between Turnouts 0203 and 0211 - no overlaps are allowed, nor is there any way to reverse the direction of flow within the Mimic panel.

The solution to this, and to any situation where there is a reversing loop or wye, is to insert a Link at the end of each stub track, and link them through another pair of Links, with identical names, to a short section of track placed on a **different** Mimic panel - in this case on the 'Pine Creek Yard - West' Mimic.

The first step is to add the Link elements to the track leading into the wye, as shown below. Note above that, as well as adding the Links, the **Mimic Title** has also been changed to be more descriptive of the current contents of the panel –

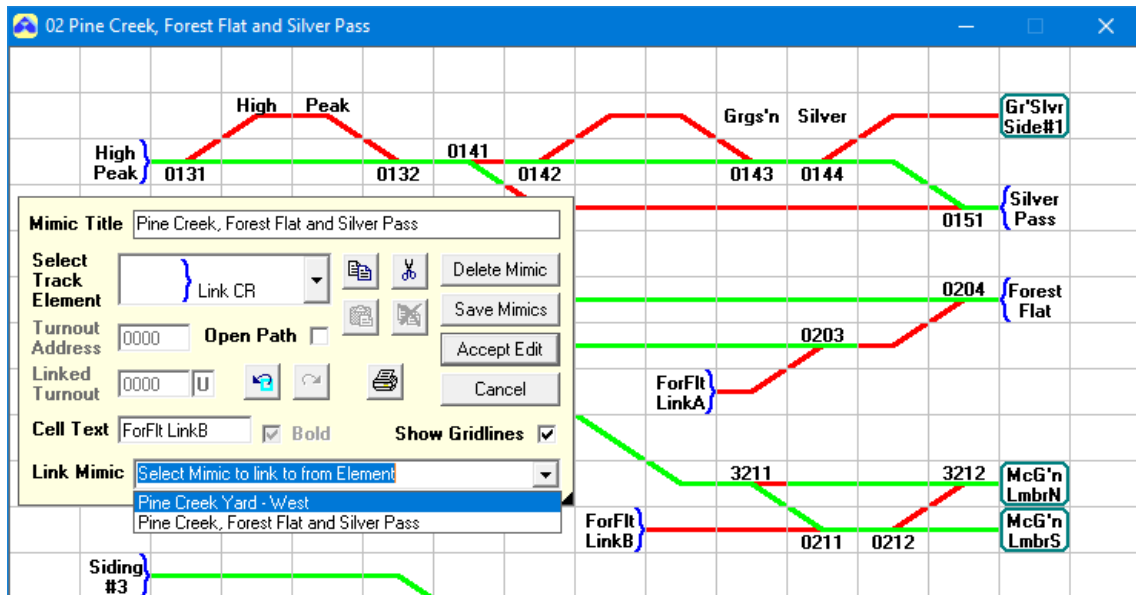

On the 'Pine Creek Yard – West' panel, we add two corresponding (and identically-named) Link elements, joined by one or two straight Track elements. Although this linking section has no effect on layout operations when we are switching turnouts manually, by double-clicking on their symbols on the Mimic, it is important when we use A-Track to find and set routes between selected points on the Mimics, as described later in **Section 8.5**.

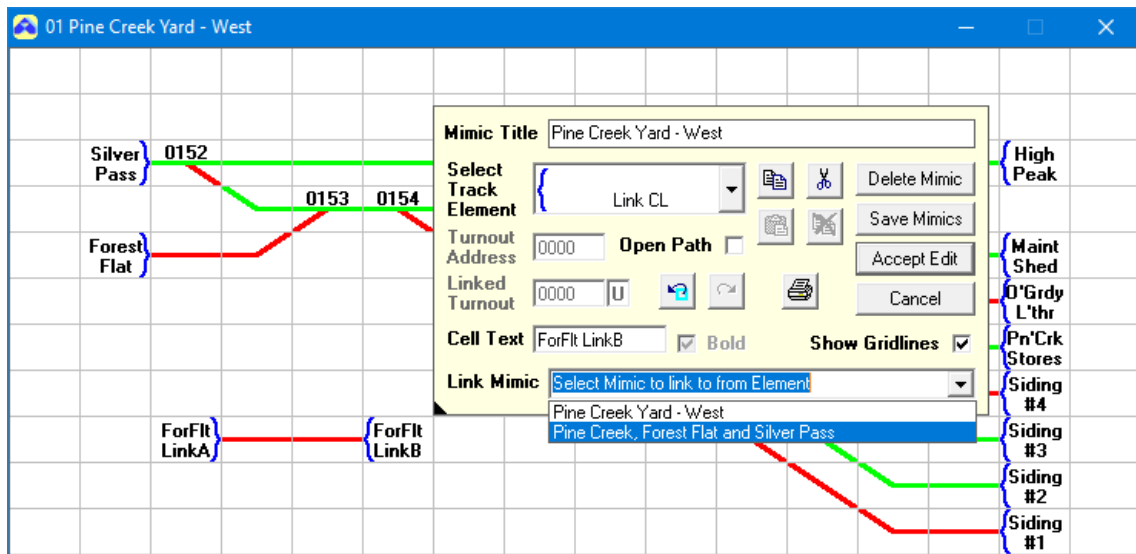

Although not implemented as part of the example layout, the same technique can be applied where the layout being drawn on a set of Mimics involves a diamond or square crossing or some types of double-slip switch. A simple crossing is drawn as shown below, with two Link elements connecting to a linking section on a **different** Mimic panel –

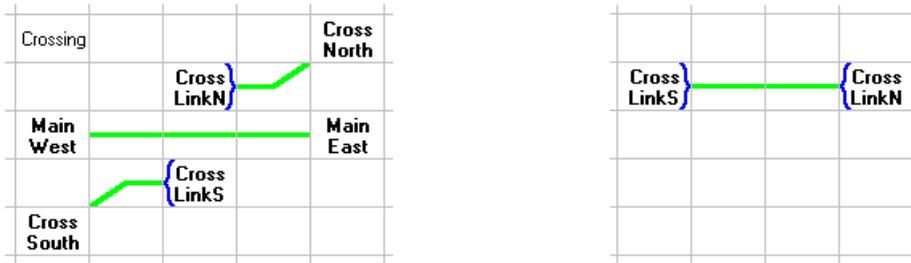

A single-slip switch, or a double-slip switch where the points at both ends are linked by a single throw-bar, is equivalent, as far as layout operation is concerned, to two ordinary turnouts placed back-to-back, as shown below (and hence does not require any linking section) -

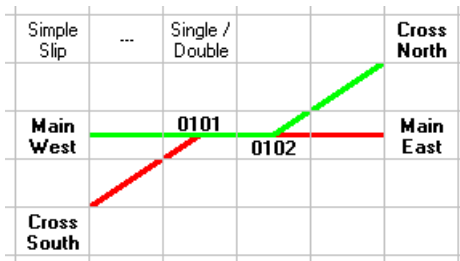

However, where all four points of a double-slip switch can be positioned independently, the switch needs to be drawn as four interconnected turnouts, plus a linking section placed on a **different** Mimic panel, as shown below, where the turnouts are set to implement a simple crossing -

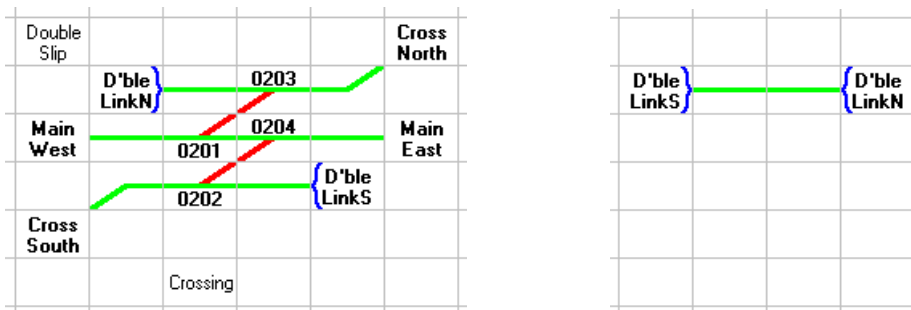

Turnouts 0201 and 0202 represent the points at one end of the double-slip switch, and turnouts 203 and 204 the points at the other end. Generally, in layout operation, turnouts 0201 and 0203 will operate as one linked pair, and turnouts 0202 and 0204 as another linked pair, to give the following switching configurations -

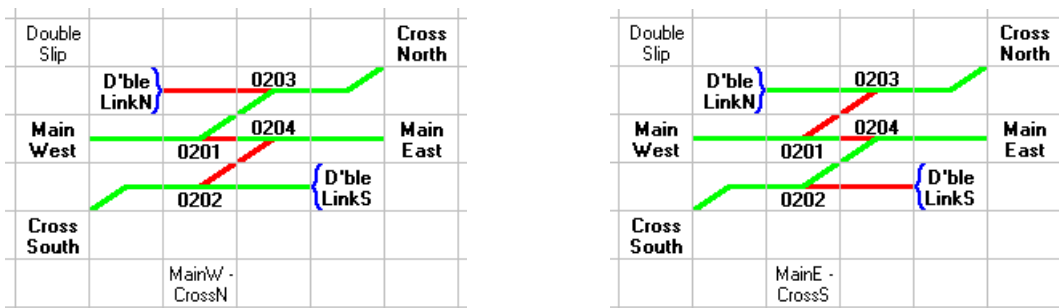

It is, of course, possible to set both pairs of turnouts (pairs of points) in the Route position to give what is sometimes referred to as the "English Connection", where both West-North and East-South routes are open at the same time (although, in practice, both routes cannot be traversed by two trains simultaneously) -

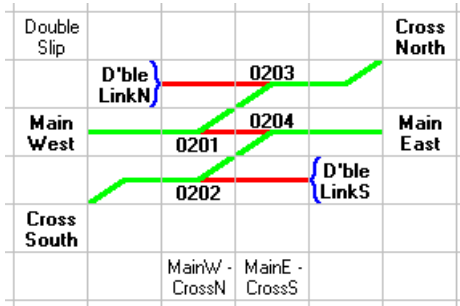

Returning to the example layout, having transferred all of the track elements completely to the two Mimic panels, we can now remove the gridlines by clicking to untick the **Show Gridlines** checkbox in the edit window on each Mimic panel, and save the Mimic Set to file using the **Save Mimics** button (or with the **Save All Mimics** option on the **Mimic** menu).

The final result will be as shown previously in the introduction to **Chapter 8** -

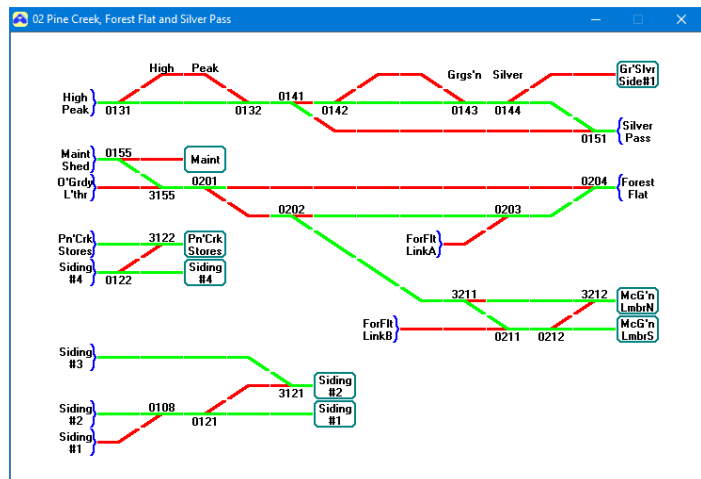
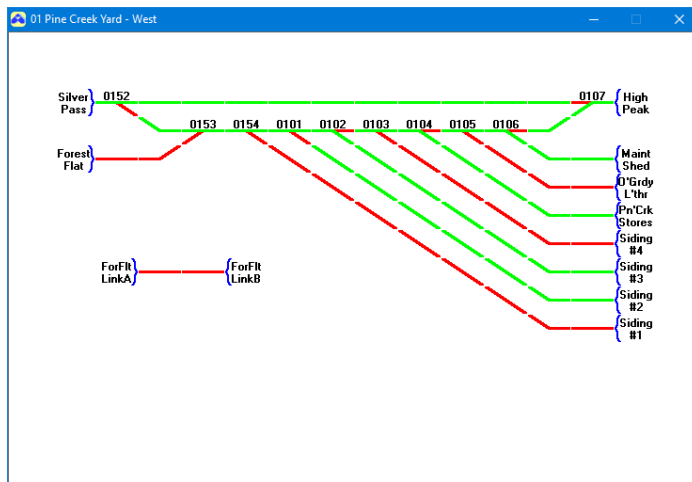

8.2 Block Editing, Printing and Sorting of Mimic Diagrams

The process of generating a set of Mimic diagrams by selecting, placing, and editing one single layout elements at a time, as described in the preceding **Section 8.1**, can be a little tedious. To alleviate this, A-Track provides several functions to help making changes (and correcting errors) a little easier. These functions can be found as a group of command buttons located in the centre of the Mimic edit window, as shown below –

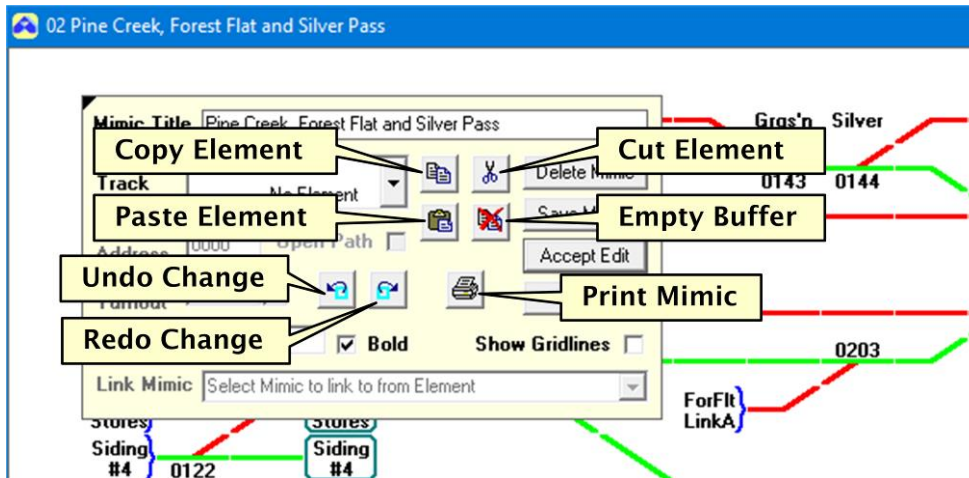

During the construction and editing of a set of Mimics, whenever *any* change is made to a Mimic panel, the details are recorded by A-Track, such that you can restore the Mimic panel to its pre-change state by opening the edit window (via a right-click on any element cell) and then clicking the **Undo Change** (↶) button.

A-Track records the last 32 changes made to each Mimic panel in the Mimic Set, independently, so that undoing changes on one Mimic panel has no effect on the changes made to any other panel, regardless of the order in which changes to different Mimic panels were made.

Any Undo operation can be reversed, to reinstate an undone change, by opening the edit window again, and then clicking the **Redo Change** (↷) button.

To copy any element which has been added to the Mimic, right-click on the element to re-open the edit window, then click on the **Copy Element** (📄) button. A copy of the element together with any parameters which have been set in the edit window is saved in an internal storage area, the Mimic Copy Buffer.

If you wish to move an element from one cell to another on the same, or on any other, Mimic panel then right-click on the element to open the edit window, and click on the **Cut Element** (✂) button. A copy of the element together with any parameters which have been set in the edit window is saved in the Mimic Copy Buffer, and the original element is removed from the Mimic panel (replaced with a blank element).

You can then paste the copied or cut element into any other cell on any Mimic panel in the Mimic Set by a right-click on the selected cell to re-open the edit window, followed by a click on the **Paste Element** (📄) button.

Elements pasted back into a Mimic retain all of their characteristics, including any associated text, with one exception. Turnout elements are always pasted back with their address set to 0000 to ensure that duplicate turnout addresses are not created

within the Mimic Set. It will then be necessary to assign a new (unique) address, from an Accessory Item present in the loaded Item List, to the pasted-back turnout before it can become active.

The copied or cut element remains in the Mimic Copy Buffer until it is replaced by another element as a result of a Copy or Cut Element operation, or cleared by a click on the **Empty Buffer** (🗑️) button. The Copy Buffer will retain its contents while the Mimics are hidden, or when a different set of Mimics are loaded. This allows you to copy elements from one set of Mimics to another.

As well as the copy, cut, and paste of single Mimic elements, A-Track also provides facilities to perform the same operations on selected blocks of elements. A block is a rectangular area comprised of two or more elements, up to the size of the complete area of a Mimic panel. To select a block of elements, click on the element in any corner of the desired rectangular area, hold down either **Shift** (⇧) key, then click on the element in the diagonally-opposite corner of the area. The selected area will be highlighted with a **light blue** rectangle, and action buttons will be displayed next to the second element clicked, as shown in the example below –

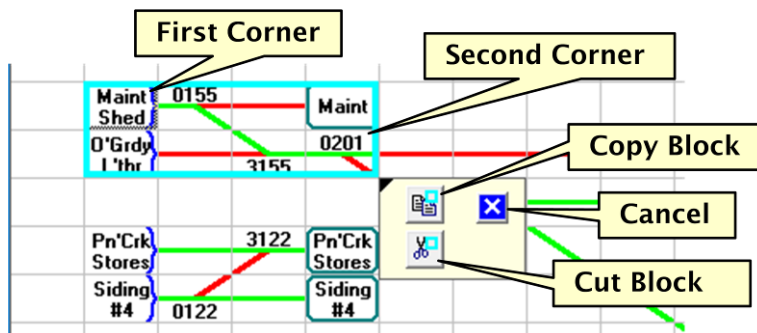

If the selected block is not quite what you intended to highlight when clicking on the second corner, simply hold down the **Shift** key again and click on a more appropriate grid cell. Conversely, if the first selected cell is not correct, just click on the cell actually required, without holding down a **Shift** key, then select the diagonally-opposite corner with another left-click and a **Shift** key held down.

Once the correct area is selected, click either of the **Copy Block** (📄) or **Cut Block** (✂️) buttons to copy the block of elements to the internal Mimic Block Copy Buffer. Using **Cut Block** will, of course, also remove the selected block of elements from the Mimic panel.

Click the **Cancel** (❌) button to abandon the block selection at any point – or simply click on any other grid cell of the Mimic panel.

The copied block of elements can be pasted back to any position on the same, or another, Mimic panel within the Mimic Set. Alternatively, since the block is retained within the Mimic Block Copy Buffer until explicitly deleted, you can load another Mimic Set and paste the copied block anywhere within those loaded Mimic panels.

To paste the copied block, right-click on the grid cell of the desired destination Mimic panel which you want be the top-left corner of the block area. The area which will be occupied by the block, when pasted, will be highlighted with a **light blue** rectangle, as shown below –

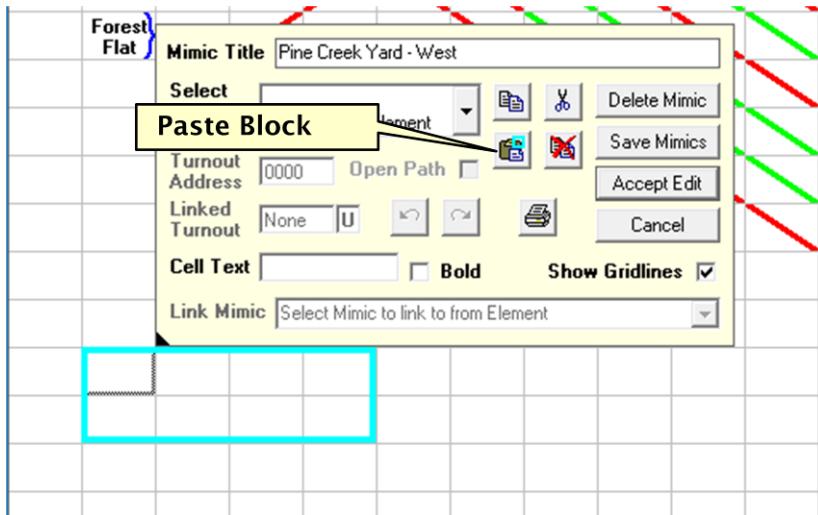

If the highlighted area is not quite what you intended, just right-click in a more appropriate grid cell until the selection is correct. Note that, if you right-click near to the righthand or bottom edges of the Mimic panel, the highlighted area will be reduced to fit, and only a part of the copied block can be pasted back.

To complete the paste operation, click the **Paste Block** (📄+) button (which replaces the **Paste Element** button). Note that, as with pasting single elements, any Turnout elements will be pasted back with their addresses set to 0000, as shown in the example below. If you then edit the Turnouts to give them addresses from Accessory Items in the Item List, they will become active and show how they are currently set, as for turnouts 0221 and 0222 which are both set in the Normal direction. However, if the edited Turnout address is not found in the Item List, the Turnout will continue to be displayed in **purple**, as for turnout address 0224 -



Note that, if you attempt to give a Turnout element (pasted or otherwise) an address which is already allocated to another Turnout element in the Mimic Set, then a warning message will be displayed -

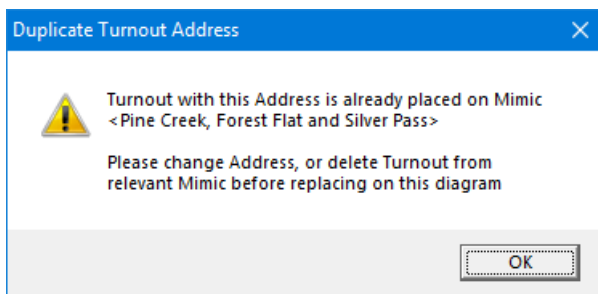

You have the options either of selecting a new (non-duplicate) address for the Turnout element, or of deleting the original Turnout element from the identified Mimic panel.

After pasting the copied block, the **light blue** area highlight will continue to be displayed whenever you right-click any Mimic grid cell, since the copied block is still stored in the Mimic Block Copy Buffer. If this is too distracting, and you are sure that you no longer require the copied block, you can remove the highlight (and clear the Buffer) by clicking the **Empty Buffer** (🗑️) button.

The final option available in the Mimic edit window is the **Open Path** checkbox, which affects how Track elements are displayed on the Mimic. The state of a Track element is defined by the position of the Turnout element to whose 'trailing' side the Track element is connected.

In the example below, Turnouts 0108 and 0121 are set in the Normal direction, so that Track elements connected to their main (straight-through) trailing track are considered to be **Open**, ie. can be reached by a moving locomotive, and are shown in **green**, while Track elements connected to their diverging track are defined as **Closed**, ie. cannot be reached by a moving locomotive, and are shown in **red** –

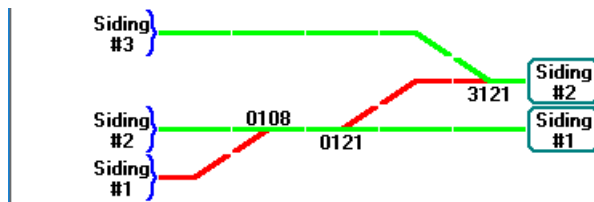

Conversely, since Turnout 3121 is set in the Route direction, Track elements connected to its diverging track are defined as **Open**, and are shown in **green**, while Track elements connected to its straight track are regarded as **Closed**, and shown in **red**.

However, if the Mimic has any Track elements connected between the 'facing' sides of two Turnouts (or between such a Turnout and a Terminal element), as in the modified example below, the state of such Track, and its connectivity to the layout, is not determined by the state of either Turnout. After such Track elements are placed on the Mimic, A-Track will just leave them displayed in **purple** –

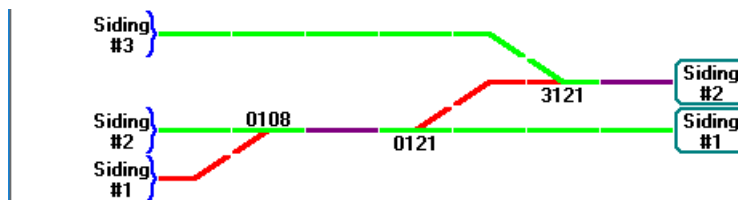

Since these Track elements are, effectively, always Open, you have the option of marking them as such, so that they will subsequently be displayed in **green**. Note that it is not essential to apply this option to the Mimic panel since it does not affect the layout connectivity nor influence the identification of routes between any two points on the layout, as described later in **Section 8.5**.

Mark any Track element as Open by right-clicking on it to display the edit window, and then clicking to tick the **Open Path** checkbox. Click **Accept Edit** to complete the operation –

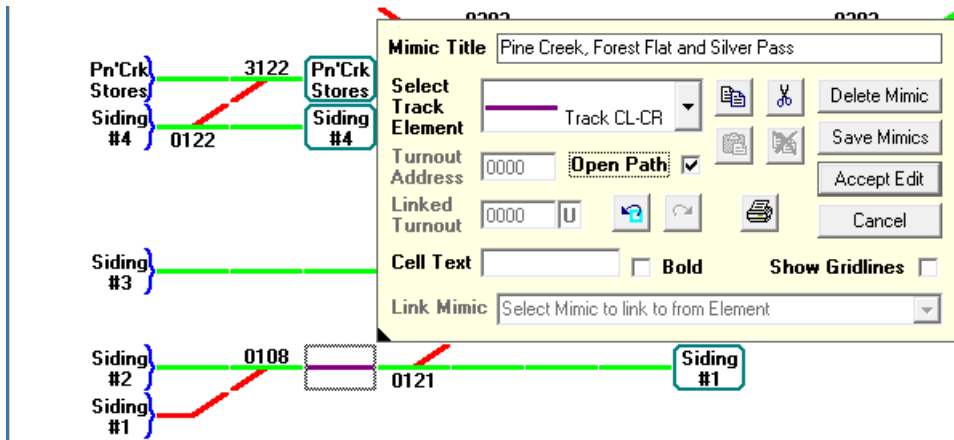

- giving the final result -

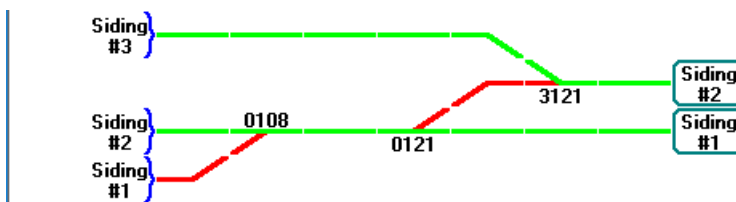

The remaining command button shown in the Mimic edit window is one to print the Mimic panel. Clicking the **Print Mimic** (🖨️) button will open a small window in the top left corner of the Mimic panel with some printing options. This window will remain visible until you click on either of the **Print** or **Cancel** buttons -

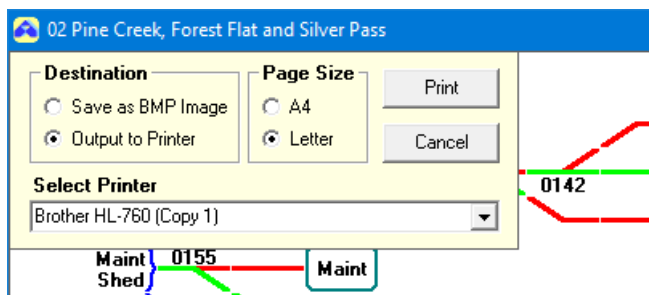

The name of whichever printer is set as the Windows default printer will be displayed in the **Select Printer** listbox.

If you wish to print to any other printer which is installed or accessible to your computer via a local network, click on the down-arrow (▼) at the righthand end of the **Select Printer** listbox to display a list of accessible printers -

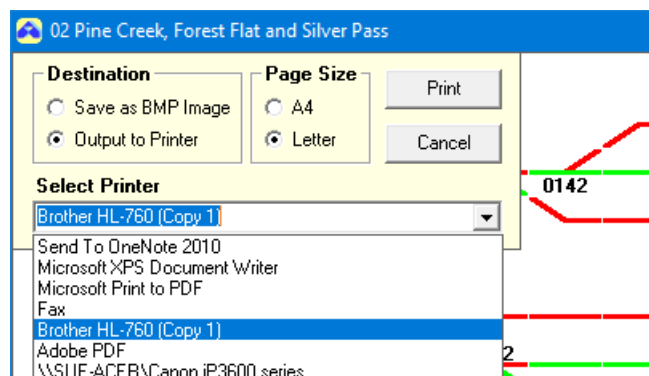

Click on the name of the required printer to select it. This printer will remain selected as the printer to use for printing any further Mimic diagrams until A-Track is closed.

Click on either **A4** or **Letter**, if the required option is not already selected, to change the **Page Size** to match the paper loaded into your printer (an A4 sheet is 297 x 210 mm or 11.7 x 8.3 inches, while a Letter sheet is 11 x 8.5 inches or 279 x 216 mm).

Finally, click **Print** to send a copy of the Mimic panel to the printer, where it will be printed in landscape mode, centred on the page, and with all margins set at approximately 10% of the page dimensions.

Alternatively, you can save a copy of the Mimic panel as an image, or picture, in bit-mapped format (BMP) to a file on your computer. You are then free to import the saved picture into a document (using Microsoft Word, for example, or even WordPad which comes free with all versions of Windows), changing the size as required. Using any suitable picture-processing program, you could also print one or more saved Mimic panel images directly on to paper, arranging the size and placement of the images to suit your own preferences.

To save the Mimic panel as an image, click the **Save as BMP Image** option. The printer options are then disabled, and the print button caption changes to **Save** -

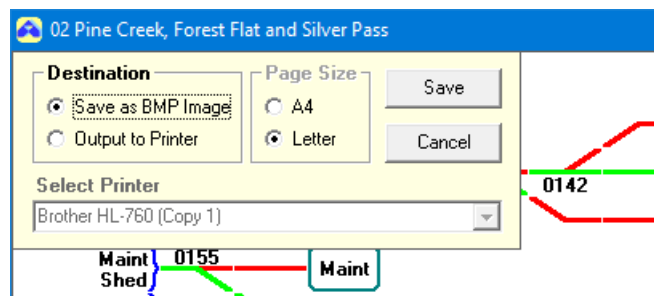

Clicking **Save** opens a standard **Save Mimic Image** dialog, with a suggested name for the image file, containing the panel number and today's date. You can choose, or create, another destination folder and edit the file name in any way you wish, although you should keep the file extension as **.bmp** so that Windows will recognise the file type correctly -

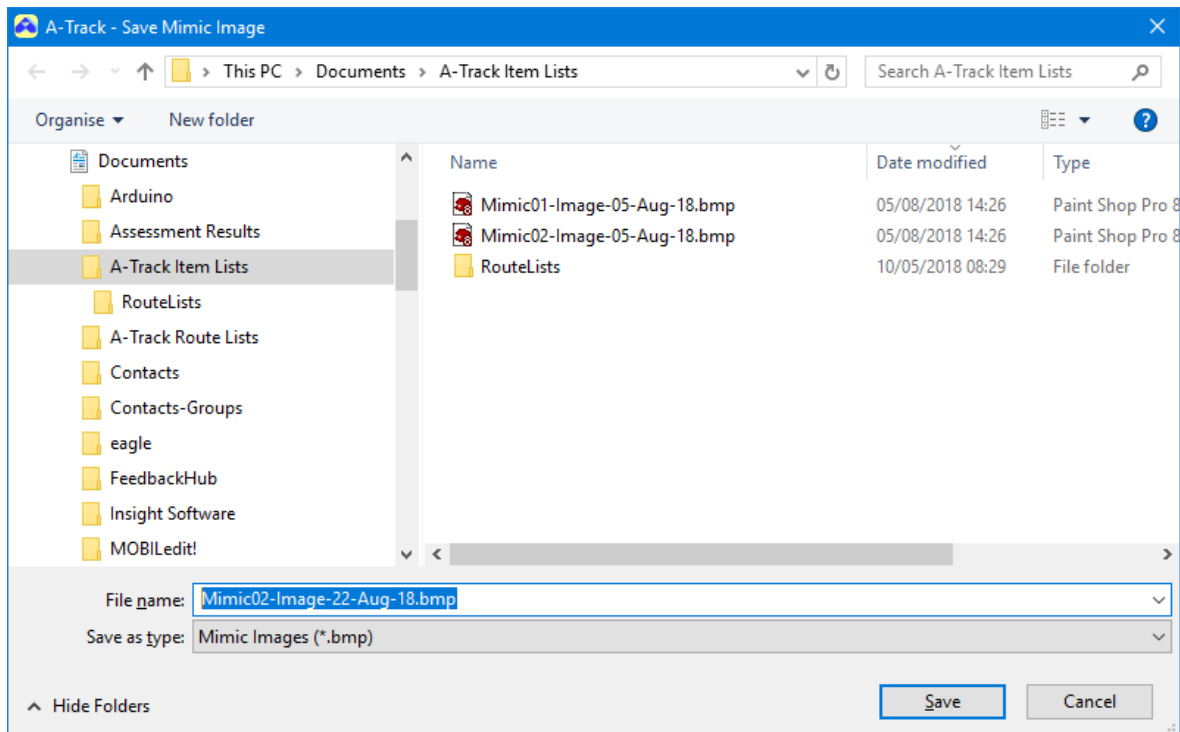

Click **Save** to transfer the Mimic panel image to the chosen destination (or **Cancel** to abandon the complete operation). A confirmation will be displayed following a successful save operation –

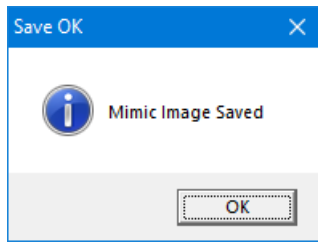

Click **OK** to continue.

Note : Image files in **.bmp** format tend to be relatively large. To save on storage space simply open the image file using a graphics application such as **Paint** (available in all versions of Windows from the Accessories folder in Programs) and then use the standard File / SaveAs option to save the file in **.png** format with lossless compression.

Although the example layout presented in the preceding Sections can be fitted on to a pair of Mimic panels, which do not require much sorting or re-ordering for display, this may not be the case where you have a larger layout requiring many Mimic panels.

Here, particularly if changes to the layout are made, you may need to split an existing Mimic panel into two panels, or just add an extra panel. Adding a panel always places it at the end of the Mimic List, so that it will be the last panel to be displayed on the screen. In this position, its track elements (Link elements in particular) are likely to be visually separated from the corresponding elements on the older Mimic panels in the Mimic Set.

To rectify this situation, or simply to rearrange the displayed order of Mimic panels in the Mimic List to suit your own preferences, open the **Mimic** menu from the menu bar and click on the **Reorder Mimic Set** option –

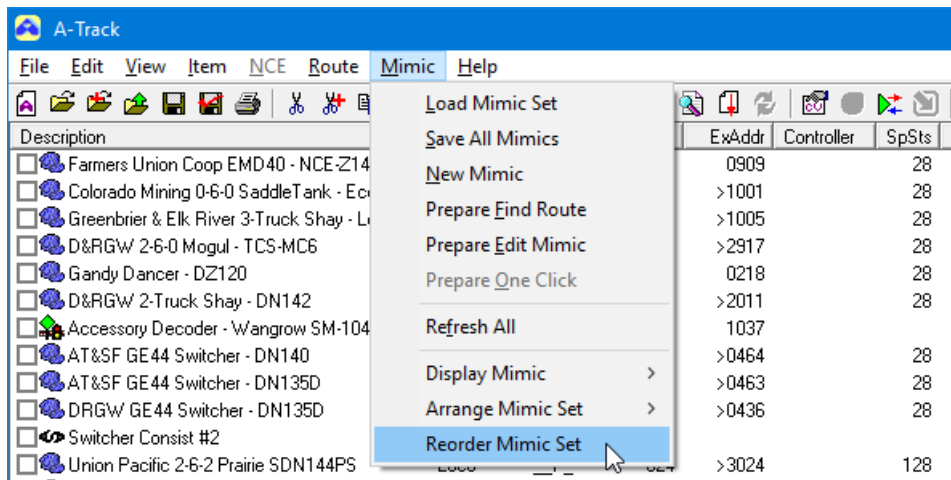

This will display a **Reorder Mimic Diagrams** window holding a list of the Mimic panels in the currently-loaded Mimic Set which, to provide a more sensible example here, contains nine Mimic panels representing a fairly large layout. Click on the **Title** of the Mimic panel whose position in the Set you wish to change to highlight it with a **yellow** background. As shown in the list below, this is Mimic #2, 'Reversing Loop (West)' –

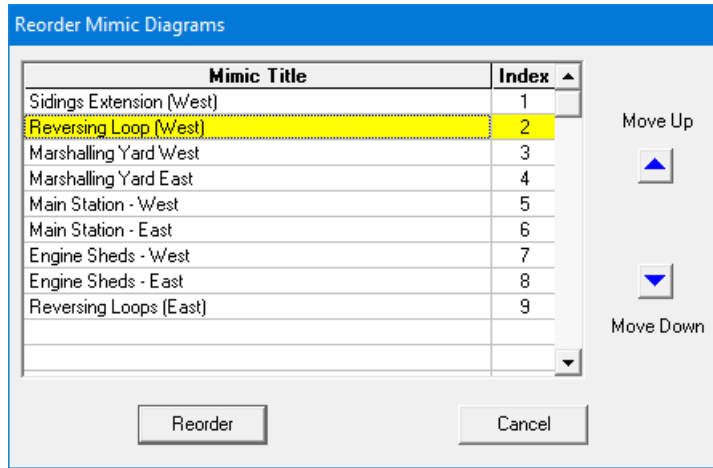

To move 'Reversing Loop (West)' next to 'Reversing Loop (East)' (Mimic #9), click the **Move Down** button six times –

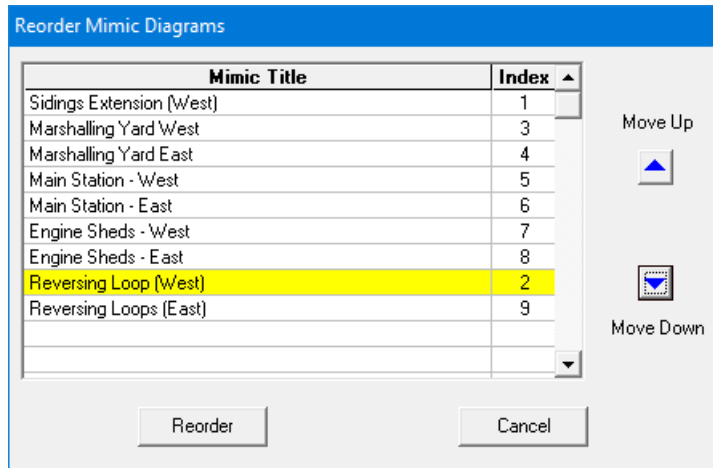

You can continue using the **Move Down** and **Move Up** buttons, with any of the Mimic panels selected, until you are happy with the order in which the panels will be displayed on screen. At this point, click the **Reorder** button to renumber all panels –

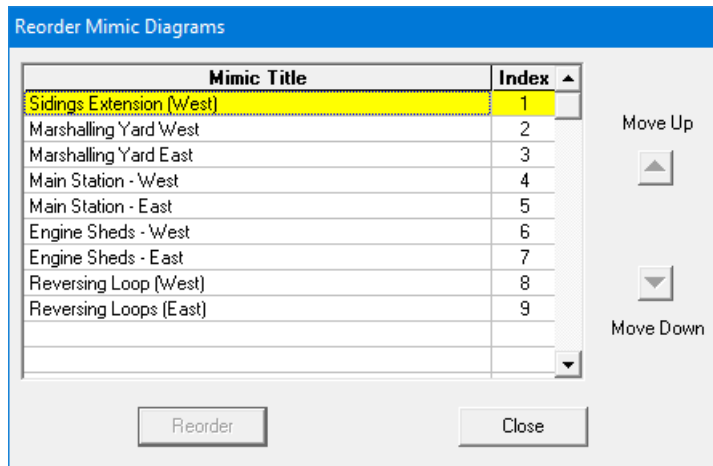

Click **Close** to remove the Reorder Mimic Diagrams window, then check that the Mimic panels are displayed in the relative positions that you intended. If not, repeat the exercise until the result is correct. You should then save the reordered Mimic Set to file as explained in **Section 8.1**, using either the **Save Mimics** button on any Mimic Edit window, or the **Save All Mimics** option from the **Mimic** menu.

If you neglect the save the reordered Mimics at this time then, when you eventually shut down A-Track, you will see a reminder –

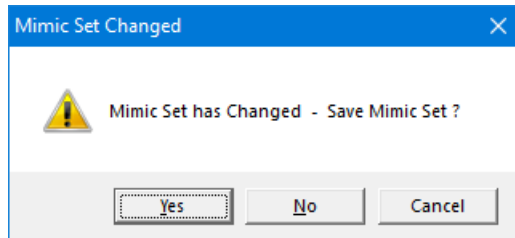

Click **Yes** to save the Mimic Set or **No** to abandon your changes completely. Clicking **Cancel** will stop A-Track shutting down and allow you to continue with further changes to the Mimic panels, or to any other A-Track feature.

8.3 Handling of Turnouts and Display of Routes

As you may have noted during the construction of Mimic panels (see **Section 8.1**), if you double-click on any turnout, its position will change from Normal (straight) to Route (diverging), or *vice versa*, depending on its initial state. When set to Normal, the main straight track on the 'trailing' side of the turnout is Open and shown in **green**, with the Closed diverging track shown in **red**. Conversely, when set to Route, the diverging track will now be shown in **green**, and the main straight track in **red**.

If the Command Station is active at this time, A-Track will generate and output an Accessory command to set the relevant decoder Output to the appropriate state, and hence change the turnout direction. However, regardless of whether a command is output from A-Track, whenever the state of any turnout on a Mimic panel is changed, A-Track will update the displayed state of all track elements on all Mimic panels to reflect the current desired state of all turnouts.

This is done by examining each placed turnout in succession, in the order of their assigned addresses, and tracing the paths from both their straight and diverging tracks as far as the next placed turnout in each path. With the starting turnout set in the Normal position, for example, all track elements in the main (Open) path are displayed as **green**, to show it is accessible to trains, and those elements in the (Closed) diverging path are displayed in **red**. Hence, at the end of this update process. all Open routes on the layout which can be traversed by trains will be displayed in **green**, with all other routes displayed in **red** – and hence not currently accessible.

As far as the real layout is concerned, this, of course, assumes that all turnout position commands have been executed correctly to move the turnouts into position. If the layout is fitted with hardware in the form of Auxiliary Input Units (AIUs) to monitor physical turnout positions, A-Track can use this input data to verify and display the actual turnout positions on relevant Mimics, as described next in **Section 8.4**.

8.4 Monitoring Turnout Positions

While on a small layout it may well be adequate to check visually that a given turnout has changed to the correct direction in response to an Accessory command, on larger layouts, and particularly when controlling turnouts from Mimic diagrams on the computer screen, it is much more convenient to receive a positive indication back from the track that an issued command has been successfully executed.

To provide such feedback from the layout to A-Track, the first step is to add one or more NCE Auxiliary Input Units (AIUs) to your NCE system. Support for AIUs is provided by the NCE Power Pro and by Version 1.65 Power Cab systems (including Smart Booster and DCC Twin) when operated via a Version 7 USB Interface (but **not** with a Version 6 USB Interface, **nor** with any of the earlier Version 1.28 Power Cab systems operating with either version of USB Interface).

One or more AIUs are added to your NCE system simply by plugging them into the NCE Cab Bus, either directly at the Command Station, or via any spare socket on an NCE UTP Panel. The diagram below shows one possible configuration, but see the relevant NCE documentation for further information –

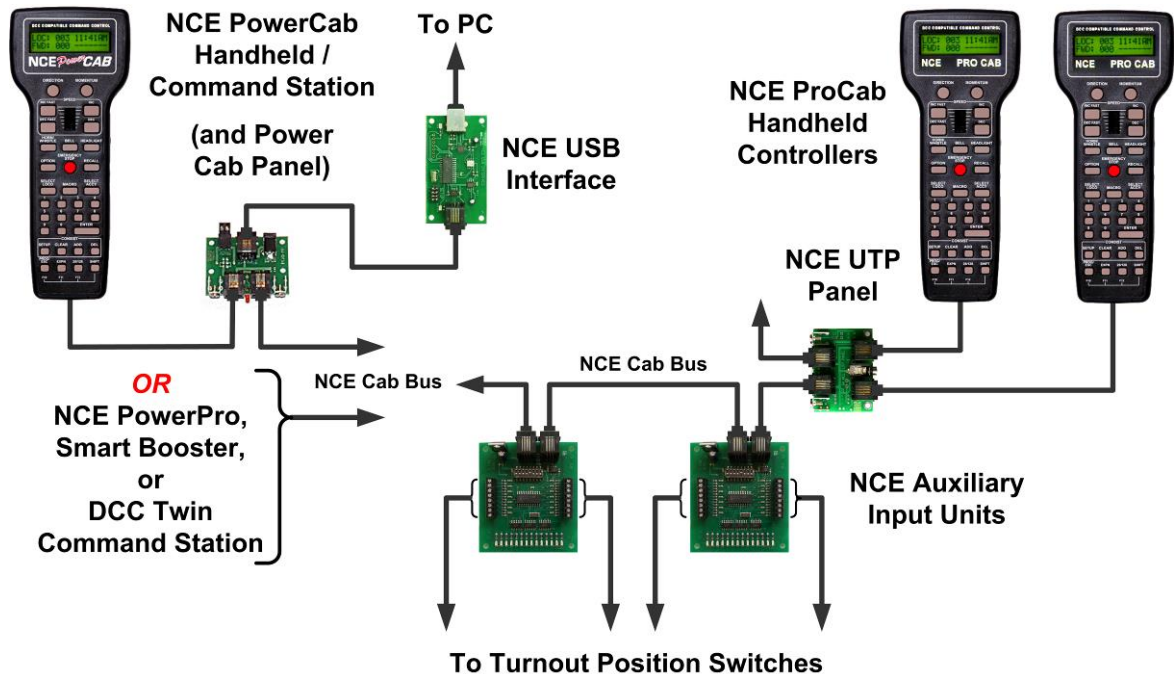

Each turnout to be monitored on the layout needs to be fitted with an electrical switch, mechanically linked directly to either the turnout throw-bar or to the turnout actuating machine (motor). Slow-motion (stall) turnout machines such as Tortoise and Cobalt already incorporate suitable switches for this purpose, but external switches generally have to be added where you are employing solenoid (snap) motors or servos to throw your turnouts. Full details of the wiring required to connect turnout switches to AIUs in various scenarios can be found in **Chapter 14**.

The first consideration when connecting AIUs to your system is to assign a Cab Address to each AIU, by setting the block of small DIP switches on the AIU board in accordance with the AIU documentation. With an NCE Power Pro system, you can use any address in the range 02 to 63, although the recommendation is to restrict AIU

addresses to the range of 50 to 63. A more restricted choice of addresses is available when using a Version 1.65 Power Cab system, which reserves address 08, 09, and 10 for AIUs and like devices. A-Track sets the Cab Address of the USB Interface to 10, leaving addresses 08 and 09 available to AIUs. If you need to add more than two AIUs to a Power Cab system then you can use addresses 03, 04, or 05 at the expense of reducing the number of Handheld Cabs which can be connected. When using a Smart Booster or DCC Twin system, addresses 02, 06, and 07 are also available.

Each switch fitted to a turnout is connected to one of the 14 inputs provided by an AIU. Hence, the pair of AIUs shown above will be able to handle a maximum of 28 turnouts. Where the layout (such as the example layout discussed in **Section 8.1**) has more than 28 turnouts, it will be necessary to add further AIUs. However, to demonstrate AIU handling, we will use a reduced layout with only 28 turnouts, as shown below –

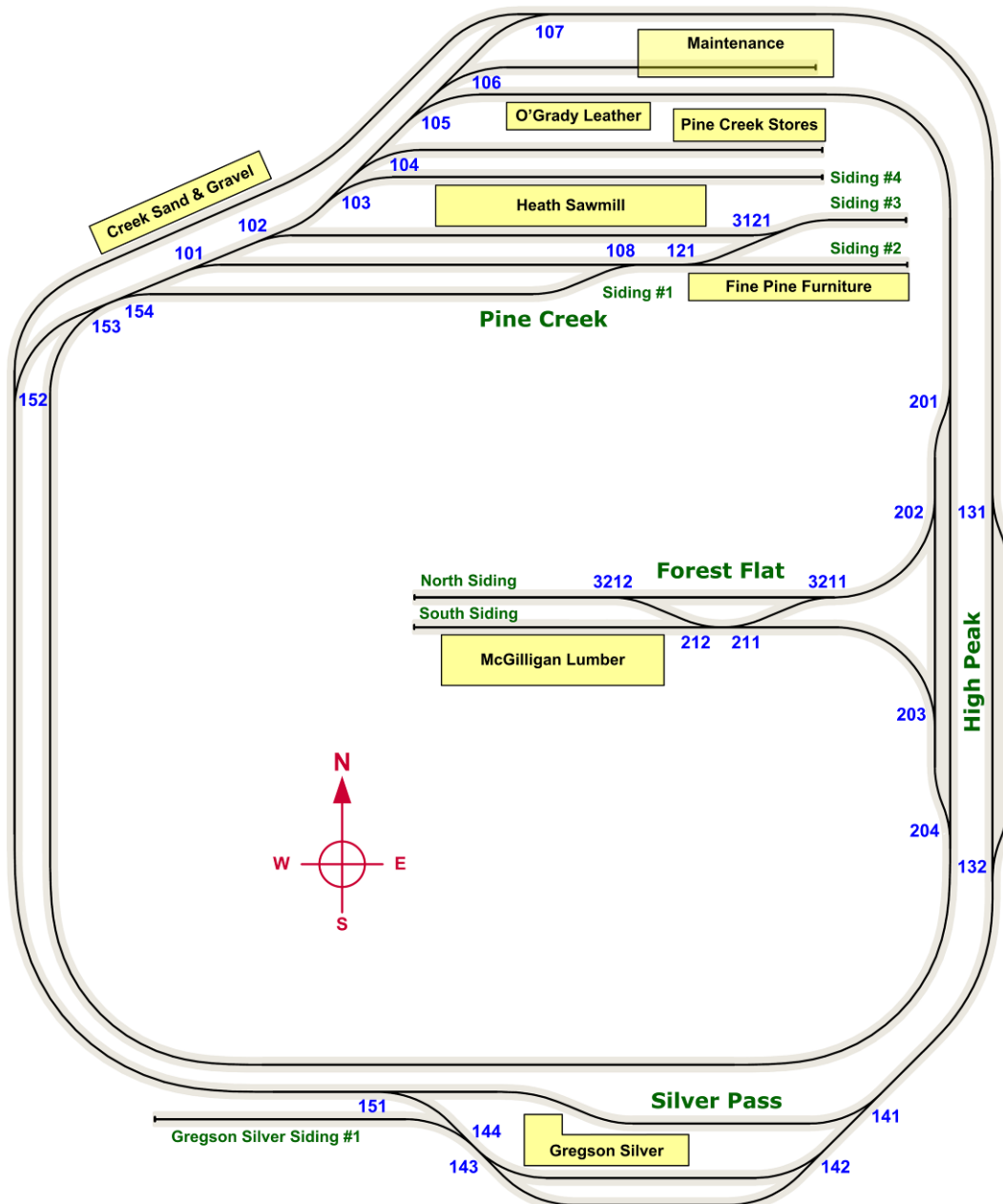

If the addresses of the two AIUs are set to 08 and 09, then they are operationally compatible with any type Command Station. Ensure, of course (particularly if you are using an NCE Power Pro system), that the addresses of any connected Handheld Cabs are **not** set to 08 or 09.

The next step is then to define which turnout is to be allocated to each AIU input. This can be done at any time, and does not require A-Track to be connected to your NCE system, although you should load an Item List which includes those Accessory Items containing the addresses of all of the turnouts you wish to allocate to AIUs. Assuming for now that A-Track is **not** connected to your NCE system, proceed by opening the **View** menu and clicking on the **AIU Status - Turnout Allocation** option to open a window which allows you to select a specific AIU by its Cab Address -

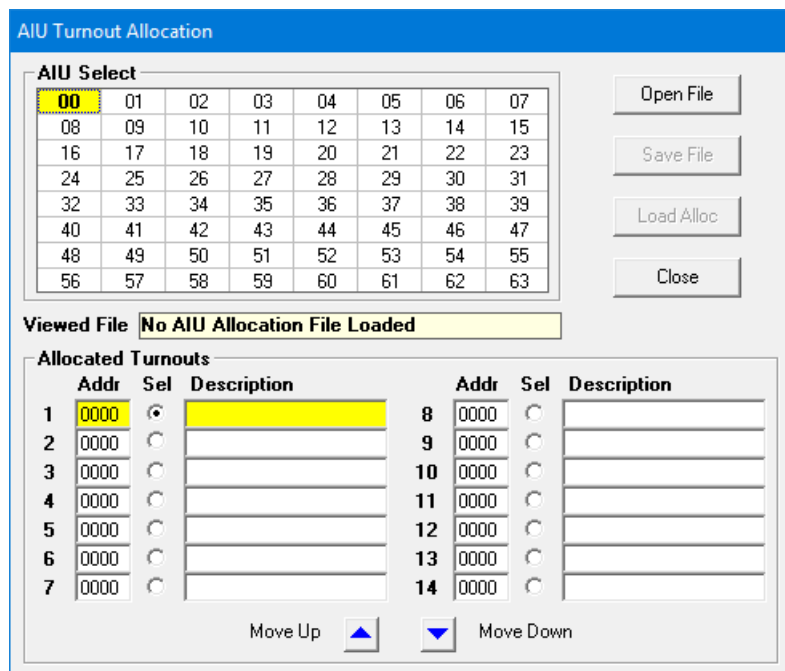
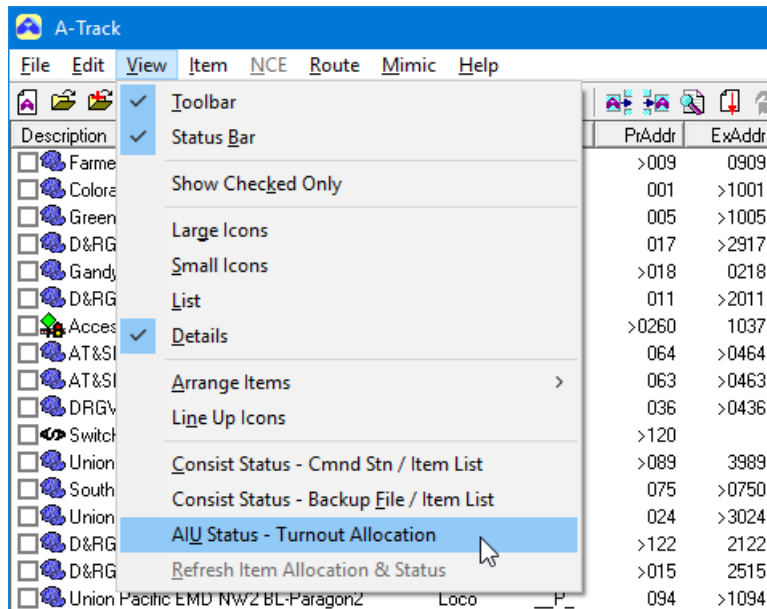

In the **AIU Select** grid, click on the address of the required AIU. A-Track will save the last AIU address selected, and automatically select it the next time you open the **AIU Turnout Allocation** window. For this example, click on Address 08 –

The screenshot shows the 'AIU Turnout Allocation' window. At the top is a blue header with the title. Below it is the 'AIU Select' section, which contains a grid of 64 cells (8 columns by 8 rows) representing AIU addresses from 00 to 63. Address 08 is highlighted in yellow. To the right of the grid are four buttons: 'Open File', 'Save File', 'Load Alloc', and 'Close'. Below the grid is a 'Viewed File' section with a yellow background and the text 'No AIU Allocation File Loaded'. At the bottom is the 'Allocated Turnouts' section, which is a table with two columns of data. The first column has rows 1 and 2, and the second column has rows 8 and 9. Each row has an 'Addr' field, a 'Sel' radio button, and a 'Description' field. In row 1, the 'Addr' field contains '0000' and is highlighted in yellow. In row 2, the 'Addr' field contains '0000' and is also highlighted in yellow.

Next, click in any one of the 14 **Addr** textboxes in the **Allocated Turnouts** area, and type the address of the turnout which is to be allocated to that AIU input. Note that the **yellow** highlight follows your selection of an **Addr** textbox. To confirm the entry, either press the **Tab** (↹) key or click in any other textbox in the Allocated Turnouts area –

This screenshot shows the same 'AIU Turnout Allocation' window. The 'AIU Select' grid and buttons are the same as in the previous screenshot. The 'Viewed File' section remains 'No AIU Allocation File Loaded'. The 'Allocated Turnouts' table now has 14 rows. The first row (row 1) has '0101' in the 'Addr' field, which is highlighted in pink. The 'Description' field for row 1 contains 'FinePineFurn - Siding #2'. The second row (row 2) has '0000' in the 'Addr' field, which is highlighted in yellow. The other rows (3-14) have '0000' in the 'Addr' field and empty 'Description' fields. At the bottom of the table are two buttons: 'Move Up' with an up arrow and 'Move Down' with a down arrow.

After entering '0101' into the **Addr 1** textbox, and clicking in the **Addr 2** textbox, note that the name assigned to turnout 0101 has been extracted from the Item List and entered into the **Description 1** textbox, and the selection highlight (**yellow**) has moved to AIU Input 2. The edited entry is highlighted in **pink** to indicate that it has been changed – this highlight will be removed once the complete allocation has been saved to a file.

Note that the retrieved **Description** cannot be edited in this window – open the Names tab in the Edit CVs window of the relevant Accessory Item in the Item List if you wish to change the name assigned to the turnout.

After clicking in the **Addr 2** textbox, you can now continue by typing in the address of the next turnout to be allocated (to AIU Input 2), and confirming your entry by clicking in yet another textbox.

Note that there is no necessity to allocate turnout addresses to AIU inputs in any particular order, and you are free to leave any inputs unallocated if you wish. The order in which you allocate turnouts to AIU inputs will be determined largely by the convenience of adding the necessary wiring between the turnout switches and the relevant AIU on the actual physical layout.

Valid turnout addresses must lie between 0001 and 2044, or 3001 and 5044 if they are linked, same-address turnouts, so that, if you enter a value outside this range, an error message will be displayed –

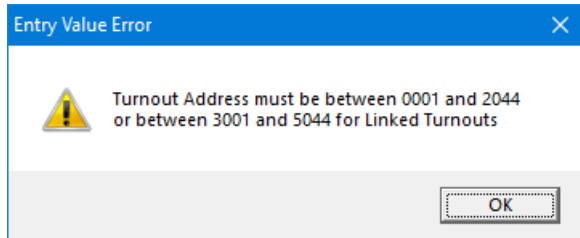

- and the entered value will be reset to 0000.

If you enter a turnout address which is not held by one of the Accessory Items in the Item List (or simply make an error in entering the address), A-Track will accept the entered address, but will display "Not Found in Item List" as the corresponding **Description**, as highlighted below for the entry in **Addr / Description 11** –

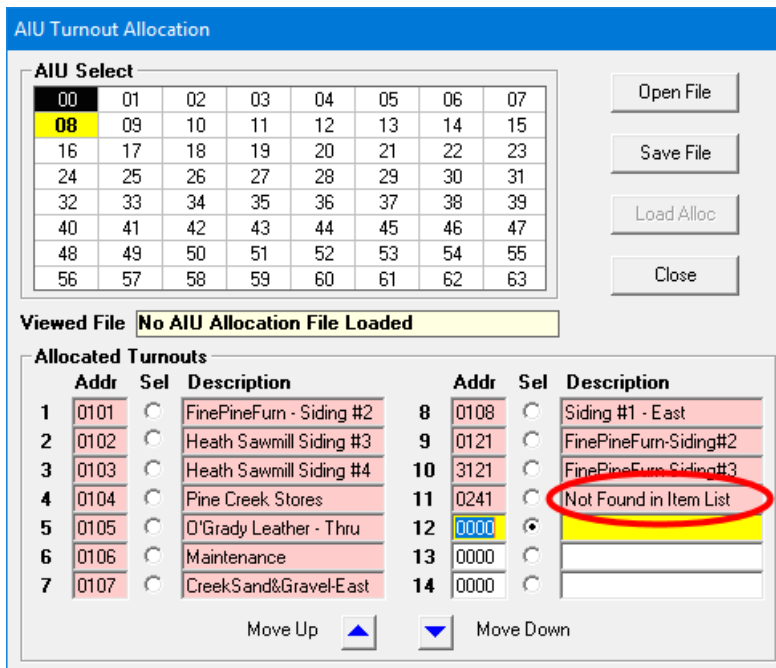

Where the entered address is correct, you should continue with allocation of turnouts to this AIU as far as required, save the entered data to a file (see below), and then add the appropriate Accessory Item with the missing turnout to the Item List. Otherwise, if you have entered an incorrect turnout address, click again in the **Addr** textbox and type in the right value.

When allocation of turnouts to this AIU is complete (or as complete as you wish), you should save the allocations so far to a file on your computer before proceeding to input data for further AIUs. Do this by clicking on the **Save File** button which opens the standard **Save AIU Allocation File** dialog shown below. Here, a new folder, **AIU-Allocation**, has been created (as a subfolder of the A-Track Item Lists folder) as a suitable destination folder for the saved file. You are, of course, free to choose, or create, any other folder in which to save your AIU Allocation files. A suggested filename for the file (based on today's date) is displayed in the **File name** textbox. This can be edited to suit your own preferences before clicking the **Save** button to save the file to the PC –

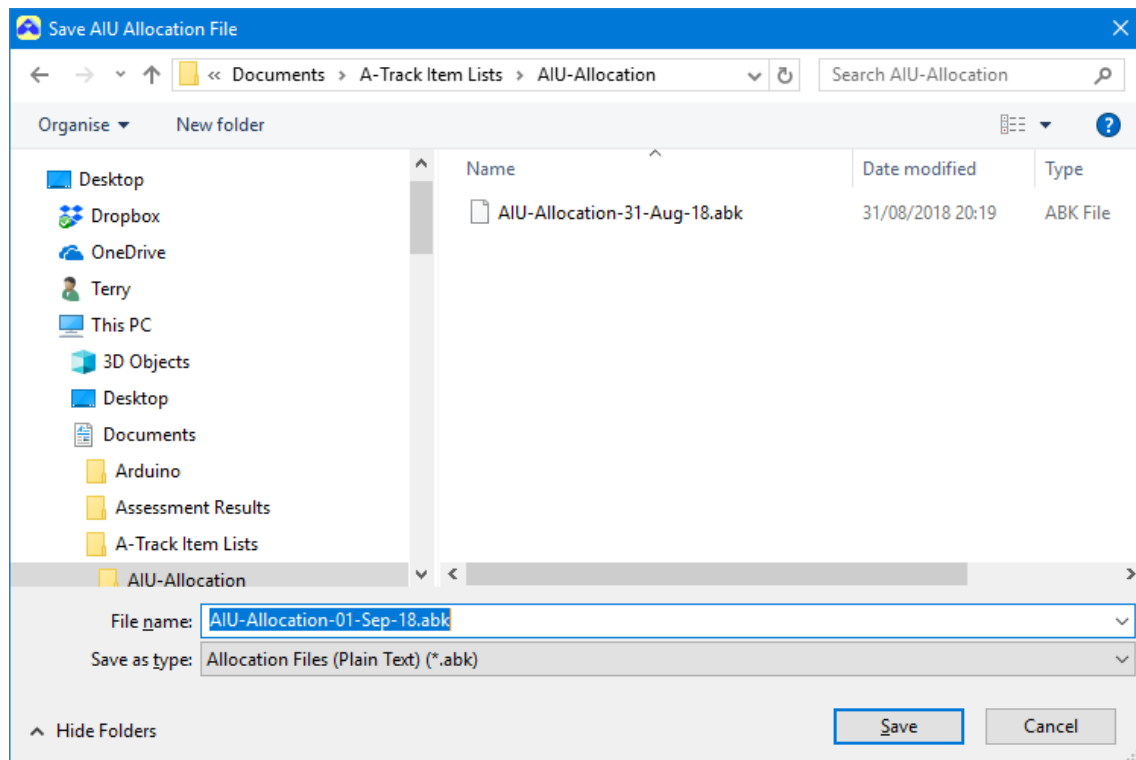

Note : Although AIU Allocation files are simple text files, they are saved with the file extension **.abk** to enable A-Track to recognise them easily. The files can be examined using Notepad, for example, but you are recommended not to try to edit them directly.

Although the contents of the saved AIU Allocation file are minimal, comprising simply the Addresses of attached Auxiliary Input Units, each with a list of the addresses of allocated turnouts, you can print an expanded version showing the given name of each turnout (as displayed in the AIU Turnout Allocation window) with the current turnout status, either to paper or to an editable file in one of a number of common formats, by clicking the **Print** option on the **File** menu –

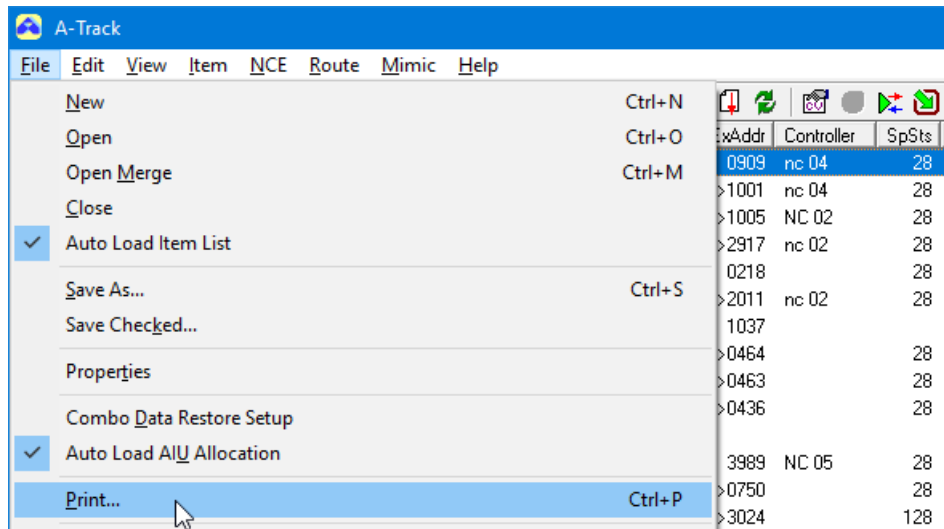

This will open a **Print Items & Lists** window where you can choose to print all, or a selected subset, of the loaded AIU Allocations. Note that there is no need to open the AIU Turnout Allocation window from the View menu in order to be able to print the file contents. The Print function will work as long as an AIU Allocation file has been loaded previously. See **Section 10.6** for full details and examples of print-outs.

Returning to the AIU Turnout Allocation window shown previously, you can now click on the address, in the AIU Select area, of the next AIU to be allocated turnouts from your layout. Continue until all turnouts have been allocated (in the case of the example layout shown earlier in this Section, this will be to AIUs 08 and 09), then click **Save File** again to update your AIU Allocation file with the added allocations.

Before the Save operation takes place, a check is made to ensure that you have not, inadvertently, allocated the same turnout address to two different AIU inputs. Should this be the case, you will see an appropriate warning displayed –

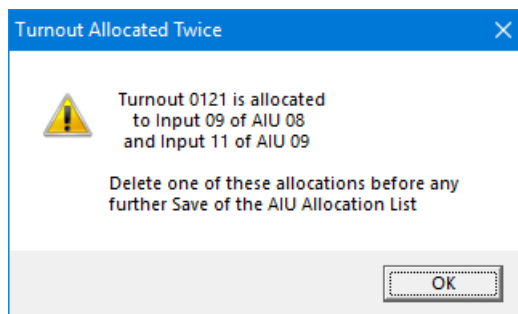

Click **OK** to abandon the Save operation, then correct the turnout allocation by highlighting one of the duplicated addresses (by clicking in the relevant **Addr** textbox), typing '0' or pressing the **Delete (Del)** key to clear the address, and then clicking in any other textbox to confirm the change.

Once all duplicated allocations are removed, click **Save File** to save the corrected file.

If you attempt to **Close** the AIU Turnout Allocation window before saving any changes you have made, then a further prompt will be displayed to remind you –

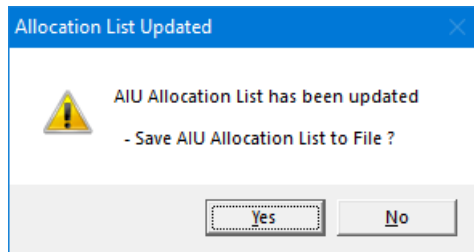

Click **Yes** to open the **Save AIU Allocation File** dialog shown previously, and save the AIU Allocation List to file, or **No** to discard all changes to the turnout allocations.

When a saved AIU Allocation List is re-opened by clicking on the **Open File** button, either immediately after saving, or after the Allocation window is closed then re-displayed from the **View** menu, you will first see a standard Open dialog very similar to that displayed previously when saving the AIU Allocation List –

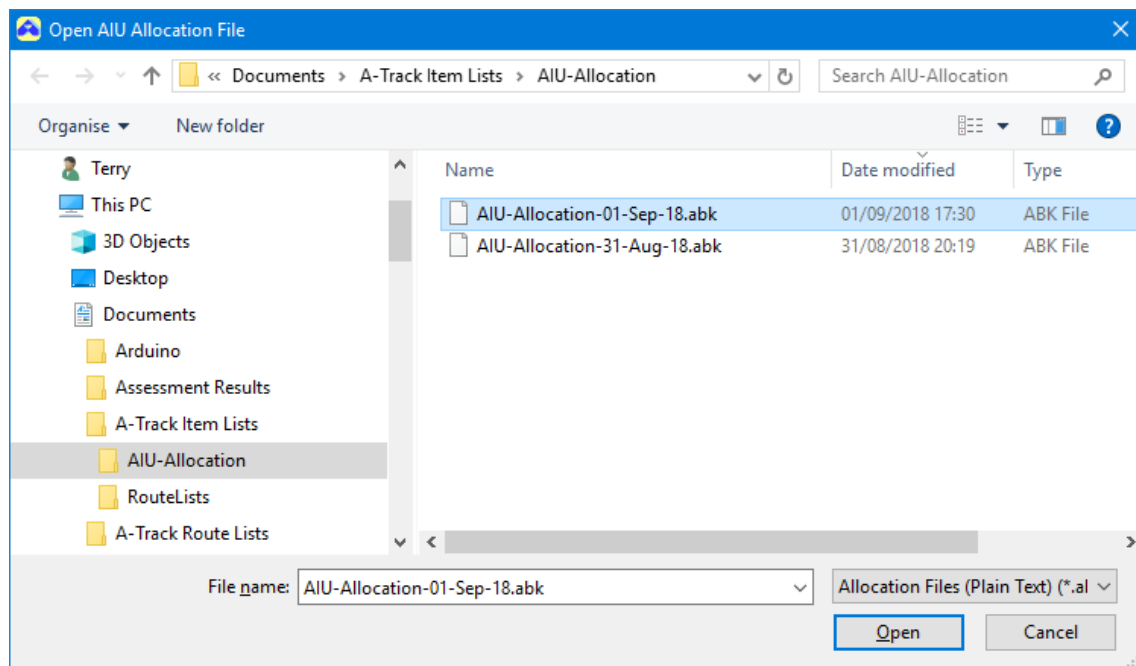

Select the appropriate file by double-clicking on it, or by a single click followed by another click on the **Open** button, to re-open the AIU Turnout Allocation window where those AIUs with allocated turnouts will be shown with a **pink** highlight, with the last-selected AIU (09 here) further highlighted in **dark red** –

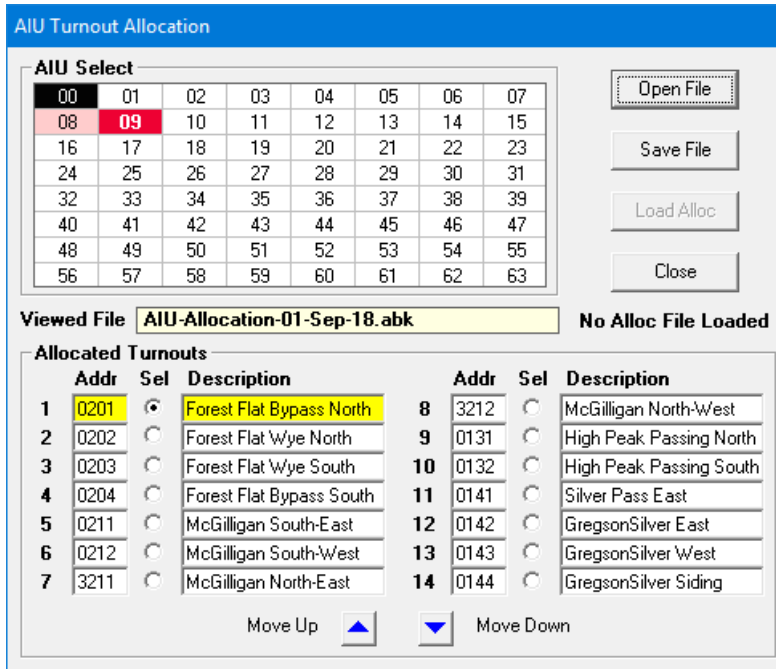

The name of the opened file is displayed in the **Viewed File** textbox and, since A-Track is **not** currently connected to an NCE Command Station (and hence no AIUs are actively monitoring turnouts) the status message '**No Allocation File Loaded**' is shown. Any further changes you make to the turnout allocations will highlight the viewed filename, as well as the relevant turnout details, in **pink**, until the allocations are again saved to a file.

However, if A-Track is connected to an active NCE Command Station, and the AIU Turnout Allocation window is opened, details of connected Cab Bus devices, including AIUs, are now displayed in the **AIU Select** area, as shown below –

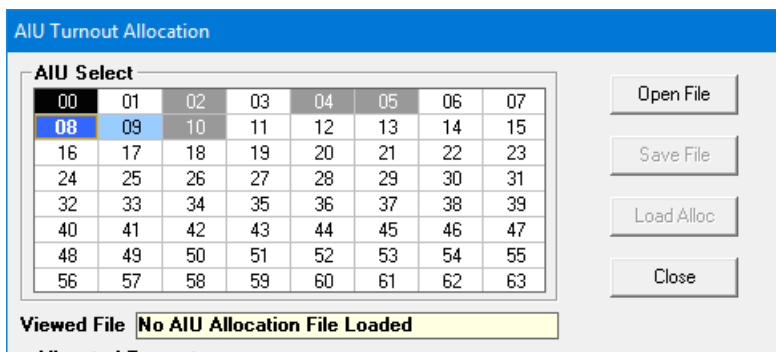

Remember, as stated in the introduction to this Section, the facility to display this information, and to handle AIUs, is **only** available when using either an NCE Power Pro system, or a Version 1.65 Power Cab (including Smart Booster and DCC Twin) when operated via a Version 7 USB Interface (but **not** with a Version 6 USB Interface, **nor** with any of the earlier Version 1.28 Power Cab or Smart Booster systems operating with either version of USB Interface).

Connected AIUs are shown in **blue**, with the selected AIU (09 above) highlighted in **dark blue**. Other devices connected to the Cab Bus are shown in **grey** – in this case

we have a Power Cab at address 02, Handheld Cabs at addresses 04 and 05, and a USB Interface occupying address 10.

An example using an NCE Power Pro system is shown below –

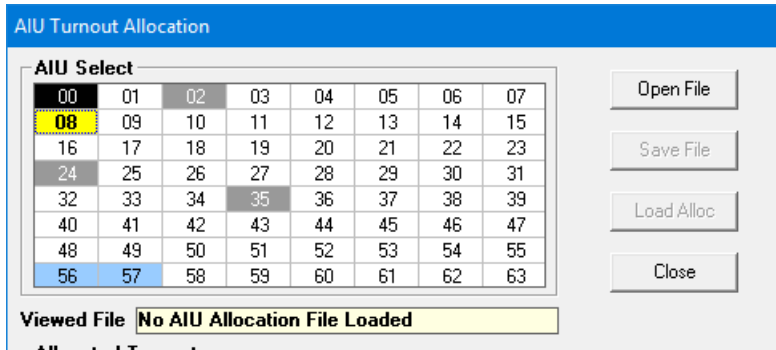

Here, Cab Bus address 08 is still selected (remembered by A-Track from the previous connection to the Power Cab system) and highlighted in **yellow**, since it does not correspond to any connected device, but the two AIUs (**blue**) have now been moved to addresses 56 and 57. We still have a Handheld Cab (actually a Power Cab acting as a Pro Cab) at address 02, with the other two Handheld Cabs relocated to addresses 24 and 35.

If the AIU Allocation List saved earlier is now opened, by clicking on **Open File**, the Allocation window will show it as still applying to addresses 08 and 09 –

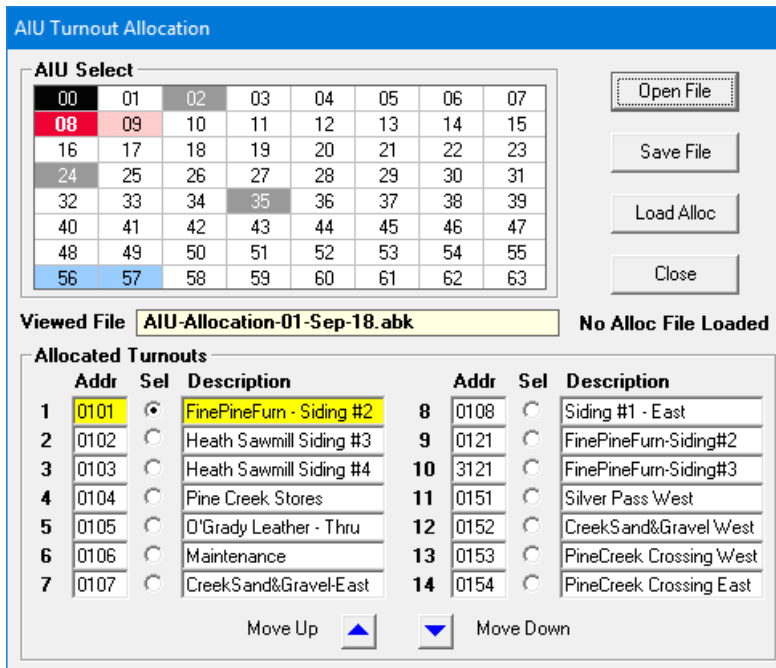

The turnout allocations currently attached to AIU addresses 08 and 09 (highlighted in **pink** or **dark red**) can be transferred to the new AIU Cab Bus addresses by right-clicking on one of the current address locations as shown below –

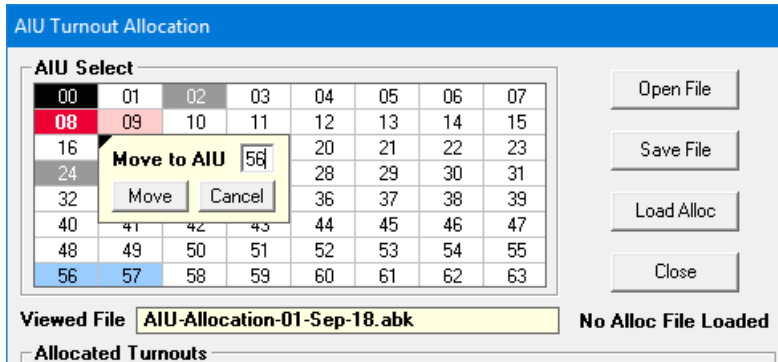

In the small window which appears (pointing to the address cell which was right-clicked – 08 here) click in the **Move to AIU** textbox and type the address to which you wish to move the turnout allocations – in this case '56' – then click the **Move** button to execute the transfer (or **Cancel** to do nothing except remove the small window).

Repeat the same actions for address cell 09, typing in '57' as the address of the destination AIU, and then click on either of the AIUs 56 and 57 to check that the turnout allocations have been successfully moved, as shown below. You should then save the revised AIU Allocation List to your PC by clicking on **Save File** as described previously, preferably with a different filename, as shown below –

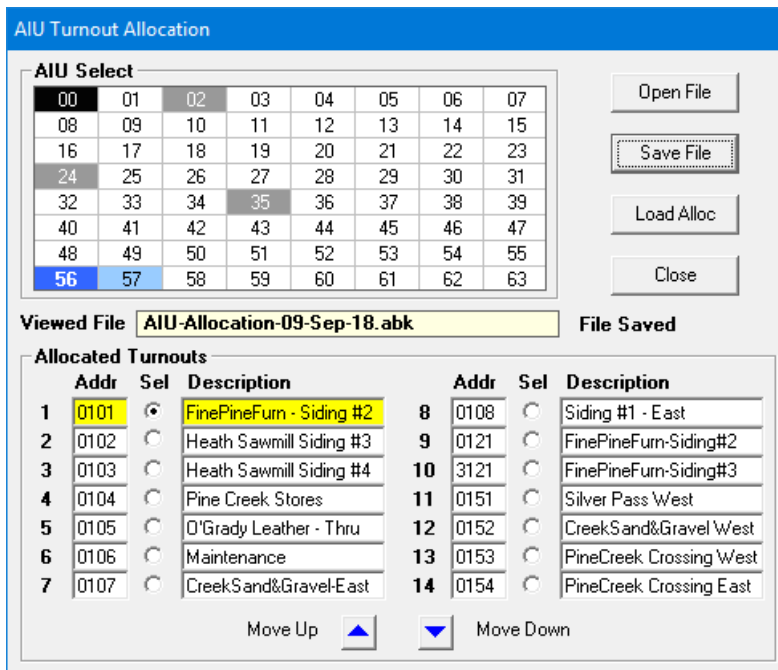

The Move facility can also be used in the situation where, when a previously-defined Allocation List is opened, you find that the Cab Bus addresses have been changed and the turnout allocation is being applied to a non-AIU Cab Bus device. In this case, the clash of addresses will be highlighted in **orange**, as shown in the example below –

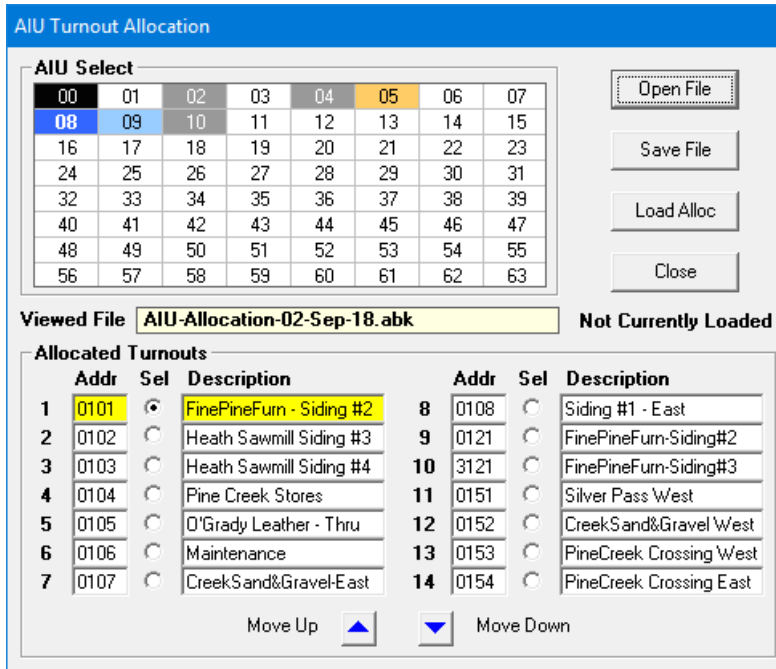

Here, the turnouts have been allocated to address 05, which is now occupied by a Handheld Cab. Transferring the allocation to the AIU with address 09 is done simply by a right-click on **AIU Select** cell 05, entering '9' as the destination, and clicking the **Move** button –

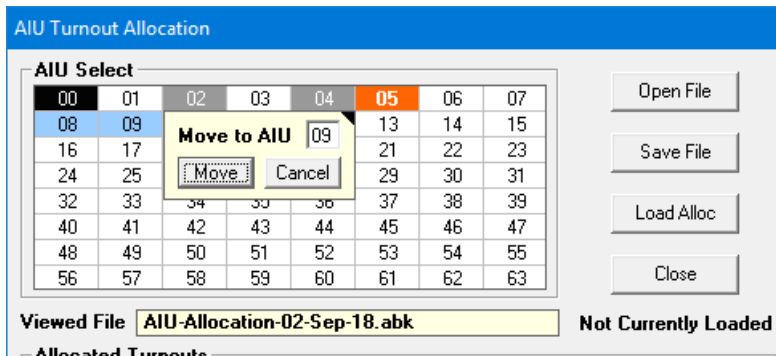



The revised AIU Allocation is then saved to a file with an appropriate filename.

As mentioned previously, there is no necessity to allocate turnout addresses to AIU inputs in any particular order, and the order in which turnouts are allocated to AIU inputs will be selected to make wiring between the turnout switches on the actual physical layout and the relevant AIU as easy as possible.



When fitting these wires, you may find that it would be simpler if some of the AIU inputs were swapped over, or otherwise moved, to untangle the usual "bird's nest" of wiring around an AIU (or fix your inadvertent wiring errors). This can be achieved by using the **Move Up** and **Move Down** buttons at the bottom of the **Allocated Turnouts** area. For example, in the allocation for AIU 08 above, we might wish to reverse the order in which turnouts 0151 to 0154 are allocated to inputs 11 through 14. Start the move by clicking the **Sel** 14 option button to select turnout 0154, the click the **Move Up** button three times –

Allocated Turnouts							
	Addr	Sel	Description	Addr	Sel	Description	
1	0101	<input type="radio"/>	FinePineFurn - Siding #2	8	0108	<input type="radio"/>	Siding #1 - East
2	0102	<input type="radio"/>	Heath Sawmill Siding #3	9	0121	<input type="radio"/>	FinePineFurn-Siding#2
3	0103	<input type="radio"/>	Heath Sawmill Siding #4	10	3121	<input type="radio"/>	FinePineFurn-Siding#3
4	0104	<input type="radio"/>	Pine Creek Stores	11	0154	<input checked="" type="radio"/>	PineCreek Crossing East
5	0105	<input type="radio"/>	O'Grady Leather - Thru	12	0151	<input type="radio"/>	Silver Pass West
6	0106	<input type="radio"/>	Maintenance	13	0152	<input type="radio"/>	CreekSand&Gravel West
7	0107	<input type="radio"/>	CreekSand&Gravel-East	14	0153	<input type="radio"/>	PineCreek Crossing West

Move Up   Move Down



Continue by selecting turnout 0153 (now moved down to input 14) and then clicking the **Move Up** button twice, followed by selection of turnout 0152 (again at input 14) and a single click on the **Move Up** button, to give the final result –

Allocated Turnouts							
	Addr	Sel	Description	Addr	Sel	Description	
1	0101	<input type="radio"/>	FinePineFurn - Siding #2	8	0108	<input type="radio"/>	Siding #1 - East
2	0102	<input type="radio"/>	Heath Sawmill Siding #3	9	0121	<input type="radio"/>	FinePineFurn-Siding#2
3	0103	<input type="radio"/>	Heath Sawmill Siding #4	10	3121	<input type="radio"/>	FinePineFurn-Siding#3
4	0104	<input type="radio"/>	Pine Creek Stores	11	0154	<input type="radio"/>	PineCreek Crossing East
5	0105	<input type="radio"/>	O'Grady Leather - Thru	12	0153	<input type="radio"/>	PineCreek Crossing West
6	0106	<input type="radio"/>	Maintenance	13	0152	<input checked="" type="radio"/>	CreekSand&Gravel West
7	0107	<input type="radio"/>	CreekSand&Gravel-East	14	0151	<input type="radio"/>	Silver Pass West

Move Up   Move Down



The movement provided by the **Move Up** and **Move Down** buttons is completely circular, so that selecting turnouts from 0144 to 0141 in turn, in the allocations to AIU 09, and successively using the **Move Down** button, allows you to interchange turnouts 0141 to 0144 with turnouts 0201 to 0204, with turnouts moving from input 14 to input 01, and *vice versa*, as shown in the example below –

Allocated Turnouts							
	Addr	Sel	Description	Addr	Sel	Description	
1	0201	<input type="radio"/>	Forest Flat Bypass North	8	3212	<input type="radio"/>	McGilligan North-West
2	0202	<input type="radio"/>	Forest Flat Wye North	9	0131	<input type="radio"/>	High Peak Passing North
3	0203	<input type="radio"/>	Forest Flat Wye South	10	0132	<input type="radio"/>	High Peak Passing South
4	0204	<input type="radio"/>	Forest Flat Bypass South	11	0141	<input type="radio"/>	Silver Pass East
5	0211	<input type="radio"/>	McGilligan South-East	12	0142	<input type="radio"/>	GregsonSilver East
6	0212	<input type="radio"/>	McGilligan South-West	13	0143	<input type="radio"/>	GregsonSilver West
7	3211	<input type="radio"/>	McGilligan North-East	14	0144	<input checked="" type="radio"/>	GregsonSilver Siding

Move Up   Move Down

>>

Allocated Turnouts							
	Addr	Sel	Description	Addr	Sel	Description	
1	0141	<input checked="" type="radio"/>	Silver Pass East	8	3212	<input type="radio"/>	McGilligan North-West
2	0142	<input type="radio"/>	GregsonSilver East	9	0131	<input type="radio"/>	High Peak Passing North
3	0143	<input type="radio"/>	GregsonSilver West	10	0132	<input type="radio"/>	High Peak Passing South
4	0144	<input type="radio"/>	GregsonSilver Siding	11	0201	<input type="radio"/>	Forest Flat Bypass North
5	0211	<input type="radio"/>	McGilligan South-East	12	0202	<input type="radio"/>	Forest Flat Wye North
6	0212	<input type="radio"/>	McGilligan South-West	13	0203	<input type="radio"/>	Forest Flat Wye South
7	3211	<input type="radio"/>	McGilligan North-East	14	0204	<input type="radio"/>	Forest Flat Bypass South

Move Up   Move Down

Note that, if you attempt to **Open** another Allocation file after making changes to the current file, you will be prompted to save the changes, and then to confirm that you still wish to open the new file (whether or not the changed file was saved) –

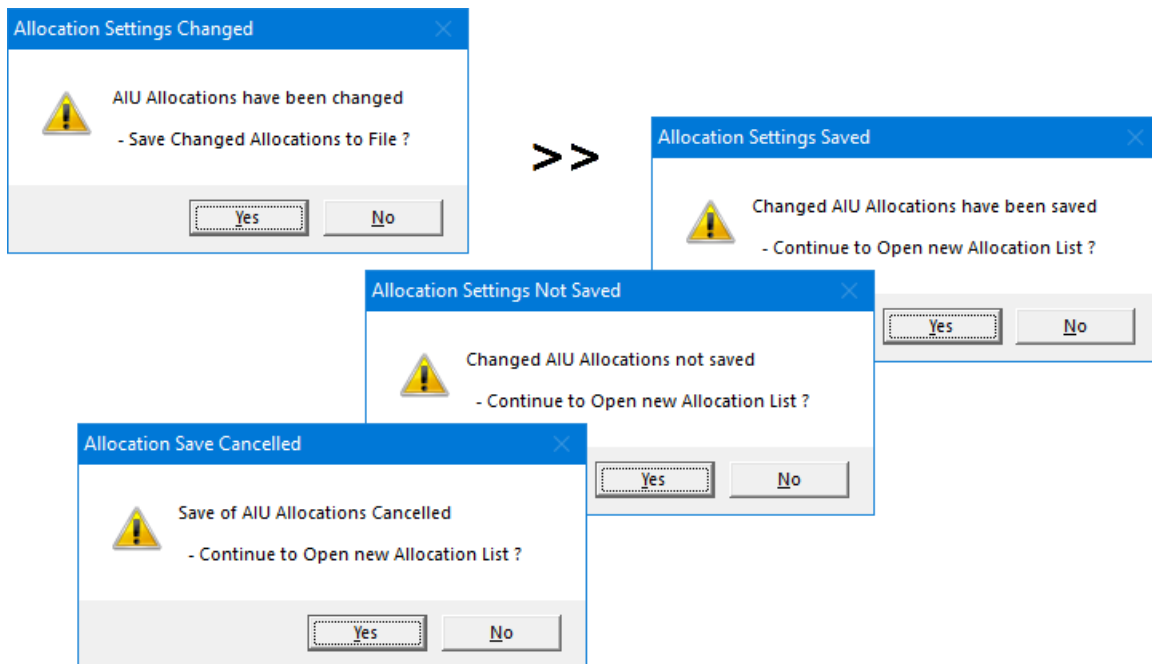

Once the allocation of turnout switches to AIUs has been defined, the next step is to link the allocation to the A-Track turnout control operations. This is done from the AIU Turnout Allocation window by a click on the **Load Alloc** button. This function is only enabled when A-Track is connected to an NCE system capable of handling inputs from AIUs, ie. an NCE Power Pro or Version 1.65 Power Cab (including Smart Booster and DCC Twin) with a Version 7 USB Interface.

Clicking **Load Alloc** transfers the data from the currently-opened AIU Allocation List file into A-Track, changing the background of the **Viewed File** textbox to **green**, and displaying the caption '**Loaded as Current**', as shown below –

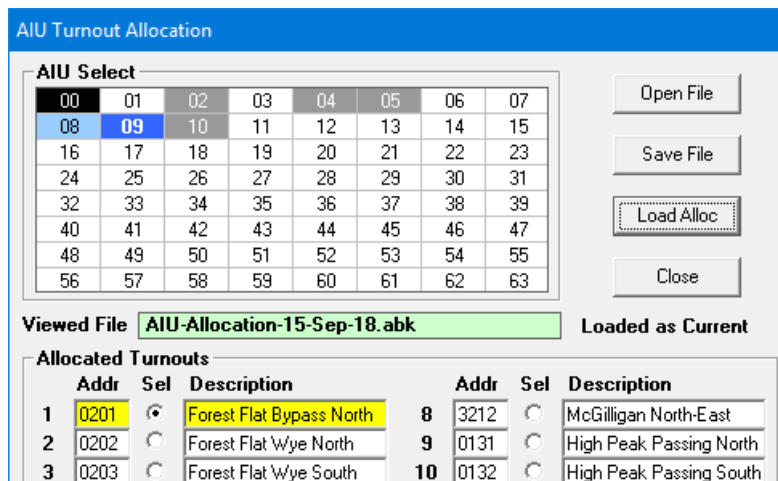

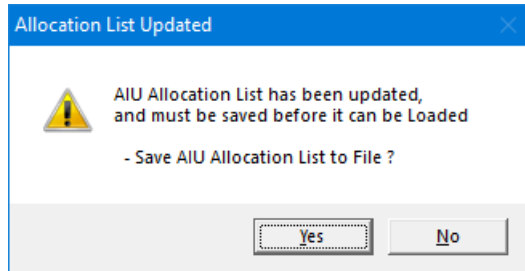

Note that, if you have not saved any changes to the to the opened AIU Allocation List file before clicking **Load Alloc**, then you will be prompted to save the changed file –

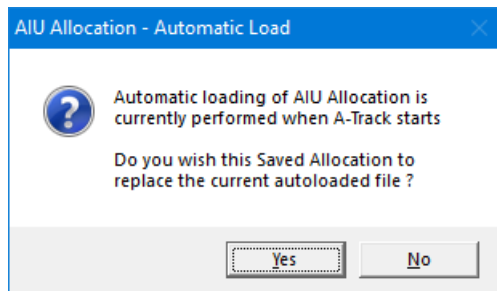

If you click **No** then the Load operation will be abandoned. Clicking **Yes** will open the Save AIU Allocation File dialog shown previously, where you can save the changed file under the suggested filename, or another of your choice. Once the file is saved, it will replace the current allocation of turnouts to the connected AIUs and you will be offered the option of setting this Allocation as the one which will be loaded automatically whenever A-Track is started –



If you simply Load the Allocation by clicking **No**, without enabling automatic loading, then you may notice that one of the icons towards the righthand end of the Toolbar changes from  to , indicating that an AIU Allocation List has been loaded –

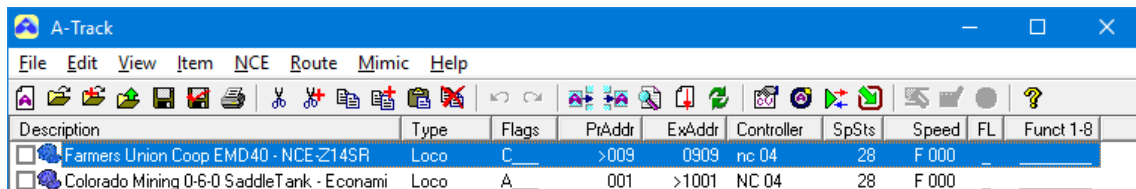

Should you need a reminder, the name of the loaded AIU Allocation List can be displayed at any time by hovering the mouse cursor over the Toolbar icon, as shown below –

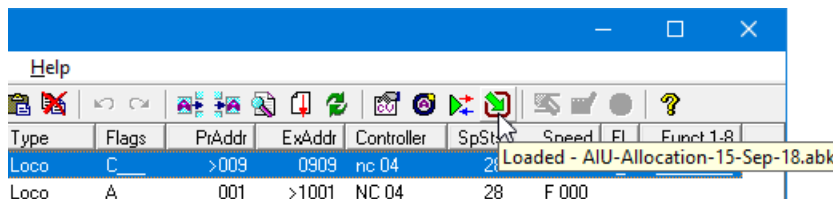

When an AIU Allocation List is loaded in this way, it only stays active while A-Track is running. After A-Track is closed and re-opened, you will find that AIU allocations are no longer loaded or active, and you will need to open and load the appropriate AIU Allocation List again in order to monitor the positions of your layout turnouts.

On the other hand, if you click **Yes** at the prompt above, to enable automatic loading of the saved AIU Allocation List, then, as well as showing the Toolbar indications described, A-Track will subsequently load this Allocation file each time the program is opened.

The autoload process can also be initiated, without opening the AIU Turnout Allocation window, by clicking on the **Auto Load AIU Allocation** option on the **File** menu , or by clicking on the AIU Allocation icon (🔴 or 🟢) on the Toolbar –

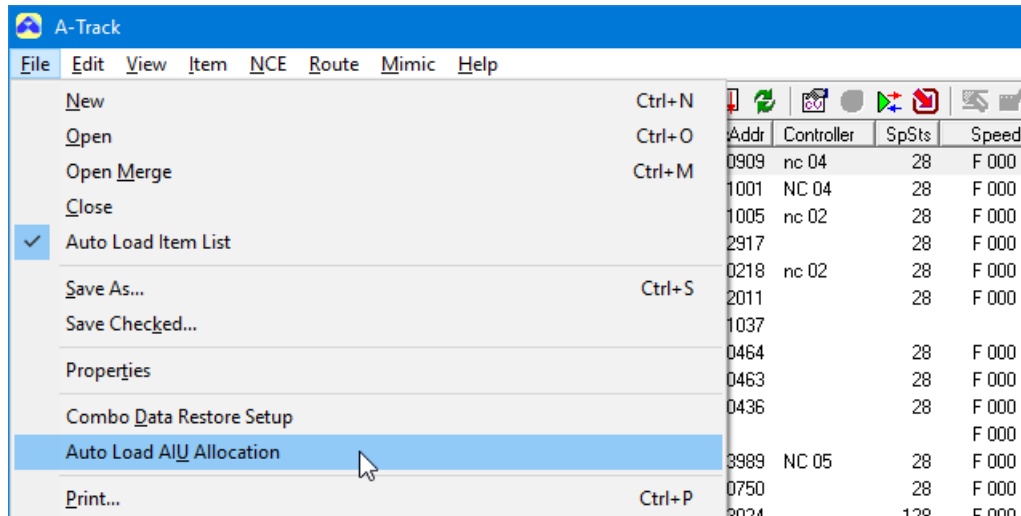

Click **Yes** to the confirmation prompt which is then displayed –

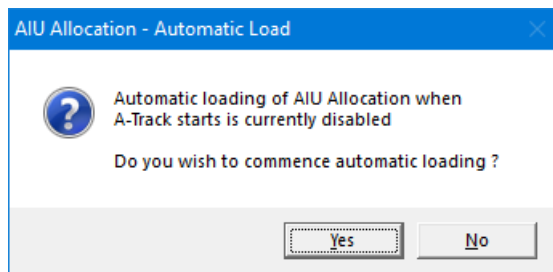

– and then, from the standard Open File dialog which appears, select the AIU Allocation List file which you wish to be loaded automatically each time A-Track is started.

If an AIU Allocation file has already been loaded manually, via the **View / AIU Status - Turnout Allocation** menu option, you will then see the following two prompts in succession –



Clicking **Yes** to the first prompt will remove the current active AIU Allocations completely, while the second prompt allows you to load another AIU Allocation List file to replace any current Allocations. If you choose to load a new AIU Allocation List at this point, by clicking **Yes**, then this file will subsequently be reloaded automatically each time A-Track is started.

When automatic loading of an AIU Allocation List is in effect, and you edit the Allocation in the AIU Turnout Allocation window, either by changing the allocation of turnouts within an AIU or by moving an allocation to a different AIU, and save the result to a new file then, when you click the **Close** button to finish editing, you will see the following prompt –

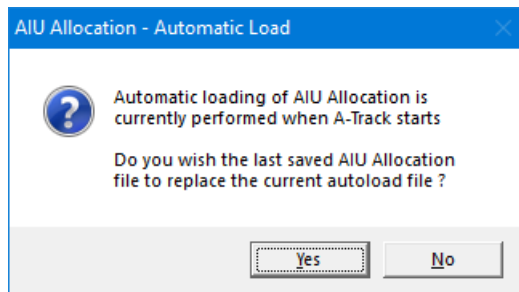

Alternatively, after an AIU Allocation List has been loaded automatically, if you open another Allocation List manually from the AIU Turnout Allocation window (opened via the **View** menu), and then click the **Load Alloc** button to make the new Allocations active, you will be prompted to confirm if this new Allocation should thereafter be loaded automatically –

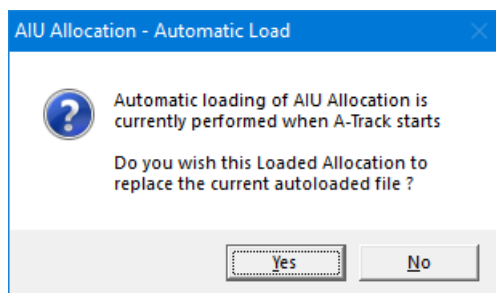

Clicking **Yes** will set this newly loaded, or modified, Allocations to be the file which will subsequently be reloaded automatically each time A-Track is started, while a click on **No** will set these loaded Allocations as active currently, but will revert to loading the previously-selected AIU Allocation List file automatically whenever A-Track is restarted.

When automatic loading of an AIU Allocation List is in effect, if the designated Allocations file is moved, deleted or corrupted, then one of two warning messages will be displayed during the A-Track initialisation sequence –

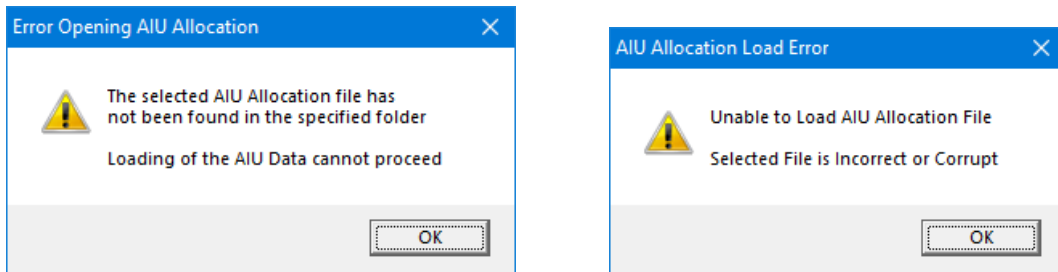

In either case, after clicking **OK**, automatic loading of an AIU Allocations List will be cancelled, and will need to be set up again once the cause of the problem is resolved.

At any time the automatic loading of an AIU Allocation List can be cancelled or changed by either opening the **File** menu, and clicking on the **Auto Load AIU Allocation** option, or by clicking on the AIU Allocation icon (🔴 or 🟢) on the Toolbar, and then following the sequence of prompts described previously.

Once an AIU Allocation List has been loaded, A-Track will scan each of the attached AIUs in turn, at 2-second intervals, determine the current state of each monitored turnout, and update any displayed turnout status. The simplest way to see this process in operation is to display one or more Mimic diagrams, such as those representing the example layout presented at the [beginning](#) of this Section –

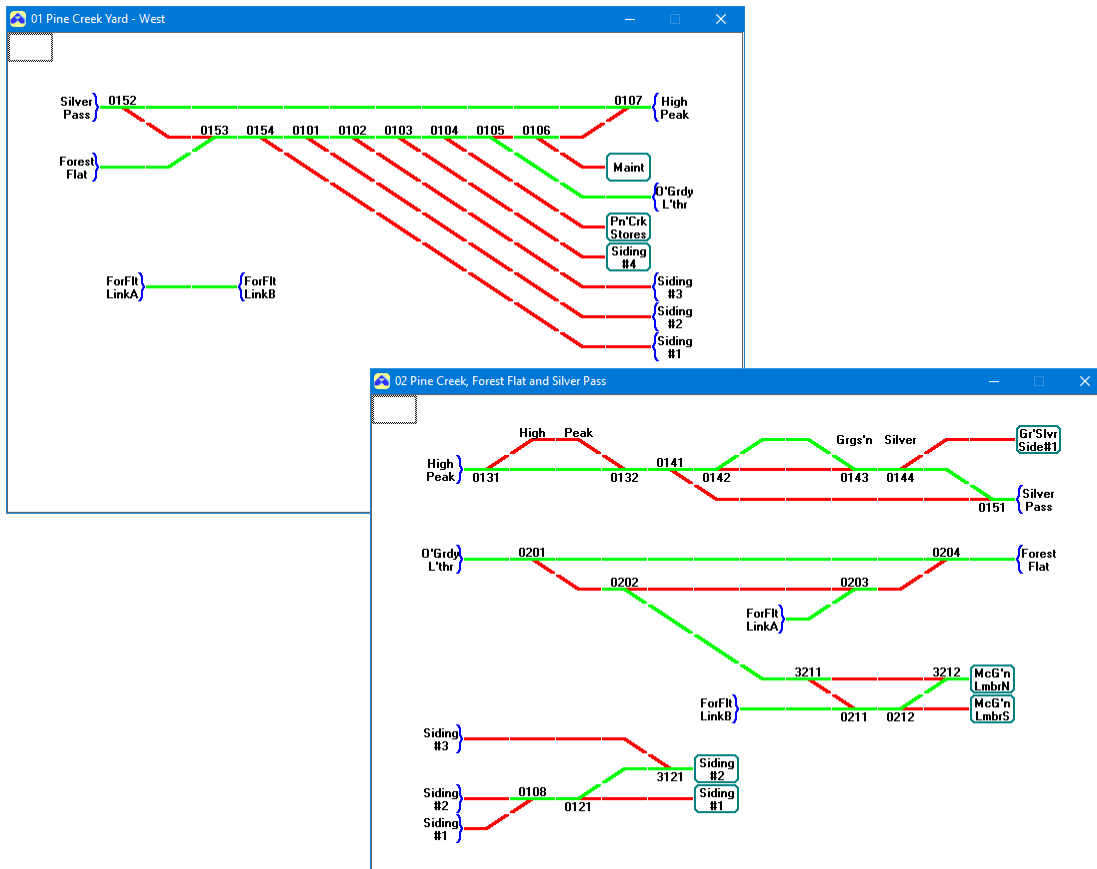

As described in **Section 8.3**, a double-click on any turnout on the Mimic diagrams will generate a command to change the direction of that turnout, ie. from Normal (straight) to Route (diverging) or *vice versa*. The changed state of the turnout is immediately shown on the Mimic. However, in addition, when the turnout has been allocated to an AIU, so that its direction is being sensed, once the Accessory command to throw the turnout has been issued, the turnout address text on the Mimic will also change to **red**, as shown in the example below for turnout 0141 –

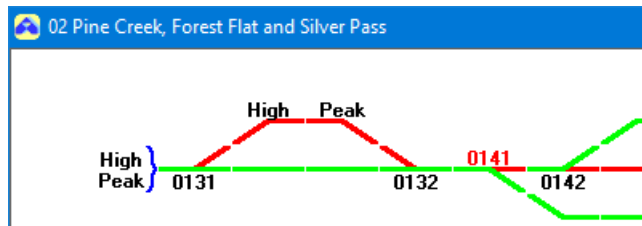

When the turnout's current direction is acquired by A-Track from the relevant AIU, and it agrees with the commanded direction, then the turnout address text will revert to **black**. However, if the turnout direction has not changed correctly, the address text will continue to be displayed in **red**, indicating that there is some problem with the turnout, or its associated switch, wiring or AIU, to be investigated and fixed.

Note that it can take several seconds for the turnout address text to revert from **red** to **black** depending on when the status of the relevant AIU is sampled following output of the turnout command. In the present example, with two AIUs being scanned in turn at an interval of 2-seconds, the maximum delay, when the turnout is thrown using a solenoid (snap-action) motor, will be 4 seconds. However, when the turnout is thrown using a slow-motion motor such as a Tortoise or Cobalt (or when using servos), the delay can be several seconds longer, depending in part on the exact point in the motor travel at which the internal electrical switch connected to the AIU is activated.

If you have linked turnouts on your layout, as described in **Section 7.2**, a double-click on either turnout of the linked pair will issue one or two Accessory commands to throw both turnouts. Where each turnout motor is driven from a separate Accessory decoder output, as in the case of turnouts 0144 and 0151 on the example layout, two commands are issued a short time apart, so that the address text of the clicked turnout changes to **red** first, followed shortly afterwards by the address text of the linked turnout, by which time the address text of the first turnout may already have reverted to **black**, as shown in the example below –

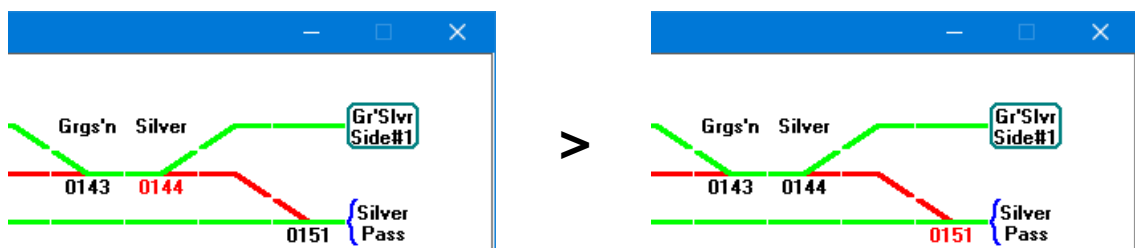

After a few seconds, if everything is working correctly, the address text of linked turnout 0151 will also revert to **black**.

Alternatively, if the motors of both linked turnouts are driven from a single Accessory decoder output, only one command is issued, and the address text of both turnouts changes to **red** immediately, as shown for turnouts 0121 and 3121 –

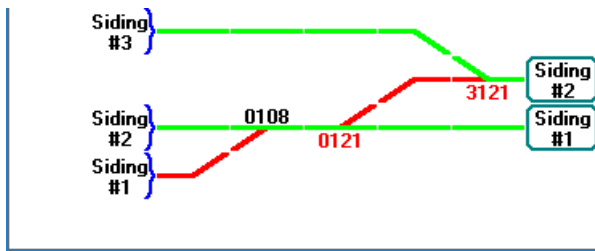

If the direction switches of both turnouts are connected to inputs of the same AIU, then their address text will revert to **black** simultaneously. Otherwise, there will be a delay of two seconds (or longer if more than two AIUs are connected) before the address text of the second turnout also changes back to **black**.

The direction of any turnout on the layout can also be set directly from any NCE Handheld Cab using the **SELECT ACCY** (or equivalent) button. If the turnout set in this manner is one which is sensed via a connection to an AIU, and you have the appropriate Mimic diagram displayed, then you will see the turnout address text change to red, as shown in the example for turnout 0104 below –

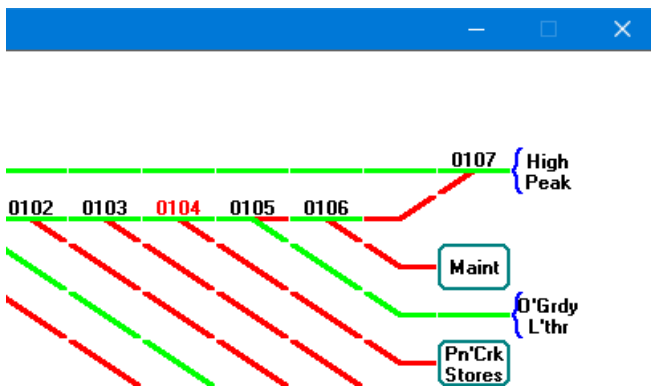

To bring the Mimic diagram back into correspondence with the actual layout, just double-click on turnout 0104. This will issue a command to set the turnout to the Route direction, which will have no effect on the physical turnout, but will update the turnout image (and associated track elements) on the Mimic and return the address text to **black**.

The status of Accessory Items in the A-Track Item List is also updated in response to sensed turnout positions. Normally, the status of the Accessory Outputs (shown in the rightmost **Funct 1-8** column of the **Details** display) reflects the commanded state ('0' for Normal or the Output Number for Route). However, if the relevant Output is driving a turnout which is sensed via a connected AIU, then the status will be updated as soon as data from that AIU is received.

In the case of the example above, where turnout 0104 has its direction changed using an NCE Handheld Cab, so that its sensed position differs from that commanded by A-Track, the Item List status display will change as shown below –

Accessory Item Controlling Turnouts 0101 - 0108				Commanded State of Turnout 0104 (0 = N)			
<input type="checkbox"/>	Clear Lake Lumber 2-Truck Climax - ZimoMX...	Loco	C_	006	>0606	nc 05	28 F 000
<input type="checkbox"/>	Pine Creek Yard - NCE Switch-8	Access'y	_P_	0026	>0102		00005008
<input type="checkbox"/>	Forest Flat - Tam Valley Quad-PIC	Access'y	_P_	0051	>0201		0230
<input type="checkbox"/>	McGilligan Lumber #2 - NCE Switch-It Mk2	Access'y	_P_	0056	>0221		02

<input type="checkbox"/>	Clear Lake Lumber 2-Truck Climax - ZimoMX...	Loco	C_	006	>0606	nc 05	28 F 000
<input type="checkbox"/>	Pine Creek Yard - NCE Switch-8	Access'y	_P_	0026	>0102		00045008
<input type="checkbox"/>	Forest Flat - Tam Valley Quad-PIC	Access'y	_P_	0051	>0201		0230
<input type="checkbox"/>	McGilligan Lumber #2 - NCE Switch-It Mk2	Access'y	_P_	0056	>0221		02

The same discrepancies can also be observed in the **Accessory Operate** 'soft controller' window described in **Section 7.4**, where the state of the Output control buttons will always reflect the last commanded state of each Accessory decoder Output, as shown below, with all turnouts are set to be in the Normal (▲) direction, except for turnouts 0105 and 0108 (▼) -

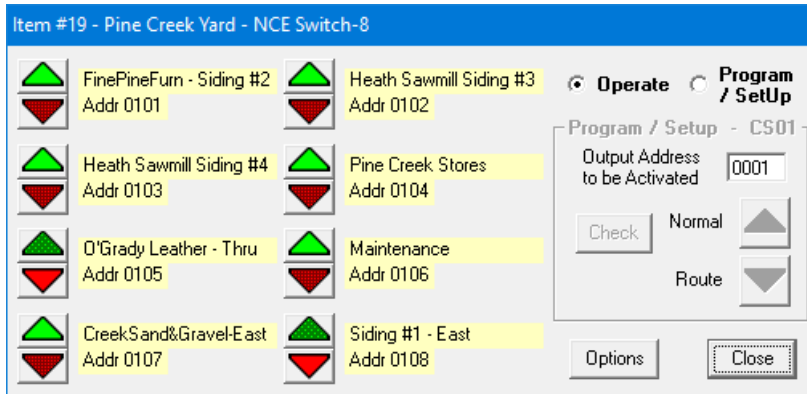

However, if the **Program / Setup** section of the window is selected, as described in **Section 7.5**, with the Output Address set to 0104, after clicking the **Check** button we can see that the actual sensed direction of turnout 0104 is Route (▼), although the commanded state remains shown as Normal (▲) -

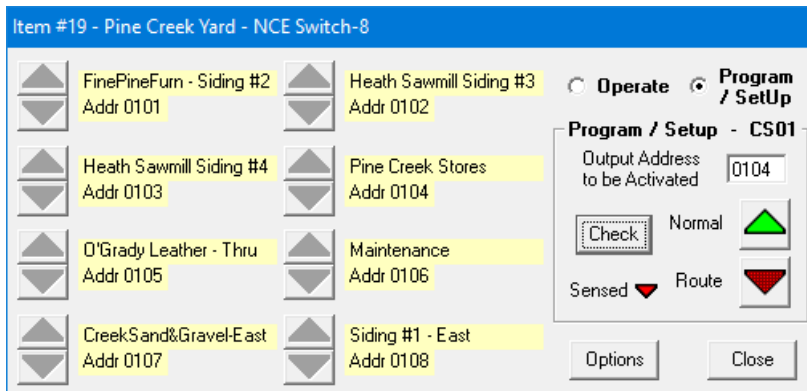

8.5 Finding and Setting Routes

As explained in **Section 8.3**, after a double-click on any turnout on a Mimic diagram, the position of the turnout will change from Normal (straight) to Route (diverging), or *vice versa*, depending on its initial state, and this will cause the state of all connected track elements to be updated to correspond. Where the section of track is Open and accessible to trains it will be displayed in **green** or, if the track is Closed or inaccessible, it is shown in **red**.

While this indication is helpful in seeing which of a series of turnouts require to be set to establish a route from one point in a layout to another, changing each turnout manually can be a little time-consuming. If you set a particular route regularly during layout operations then you can generate a Macro (see **Sections 7.6** and **7.7**) to set all of the relevant turnouts with a single action, although you still have to find the correct Macro when you need it.

As a more direct alternative, A-Track gives you the facility to select the start and end points of a required route (plus an optional mid-point) on a Mimic diagram, and then to let A-Track figure out the necessary intermediate turnout settings automatically. Once a route between the selected points has been found, all turnouts involved in the route can then be switched with a single click. The turnout settings for the found route can also, as an option, be saved as a Macro, which gives you a rapid way of generating and saving a set of Macros if that is the way you would prefer to operate your layout.

Routes are determined according to a few simple rules –

1. Start, end, and mid (or via) points for the desired route can be any Terminal, Link, or *named* Track element on the Mimic diagrams representing the layout, but cannot be any of the Turnout elements.
2. You can select the direction, East or West (right or left) that you wish the route to follow from the start point. All found routes are unidirectional, ie. they assume that the locomotive following the route does not reverse its direction of motion at any point between start and end points.
3. Once a route is found, all turnouts on the found route will be highlighted on the set of Mimic diagrams, but no Accessory commands are issued at this point to change the position of any turnout. The found route is one which involves the fewest number of turnouts between the selected start and end points.
4. If you are happy with the result then you have the option to 'run' the route, ie. to issue Accessory commands to set the necessary positions of all identified turnouts. You also have an option to save this sequence of commands as one or more Macros (depending on how many Accessory commands are required), whether or not you actually run the route at this time.
5. If the found route is not considered satisfactory, then you can simply cancel the result without issuing any Accessory commands or changing the current state of the Mimic diagrams. You can then try again with, for example, a different mid- or via-point, or by splitting the route into two parts with a change of direction at the split point.

To demonstrate the route-finding facility, we will use the simplified layout shown in **Section 8.4**.

To select a start point for a required route, hold down either **Ctrl** (Control) key on the keyboard, then left-click on the desired start point to open a Route Select window. In the example below, the Link element labelled 'Silver Pass' has been selected –

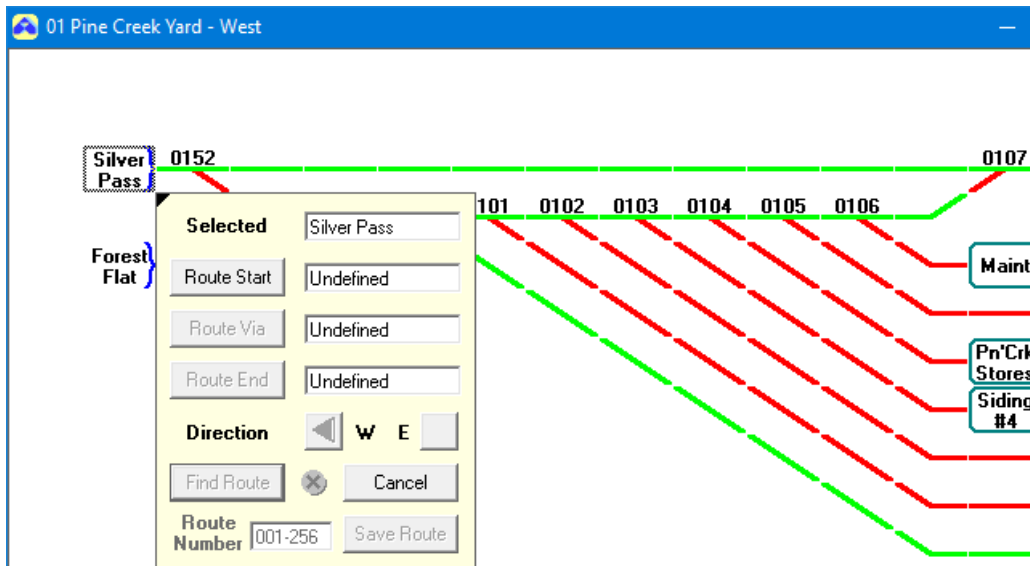

Click the **Route Start** button to confirm the selected element as the route start point, to copy the element label to the adjacent textbox, and to enable the entry of route end and via points using the **Route End** and **Route Via** buttons, respectively –

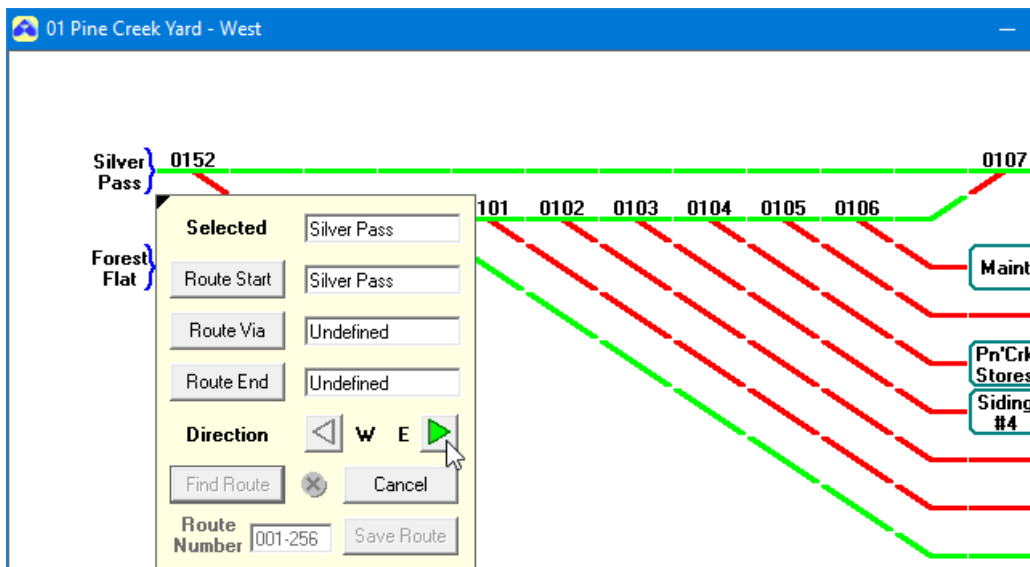

The route **Direction** buttons (**W** and **E**) are also enabled, and you can select the required route direction either now or later in the selection process.

For this first example, we will select only a route end point. To do this, left-click on the 'Pn'Crk Stores' Terminal element while holding down either **Ctrl** (Control) key on the keyboard then, when the Route Select window appears, click the **Route End** button. Leave the via point as 'Undefined', and set the route **Direction** as Eastwards by a click on the **E** button (if not selected earlier) –

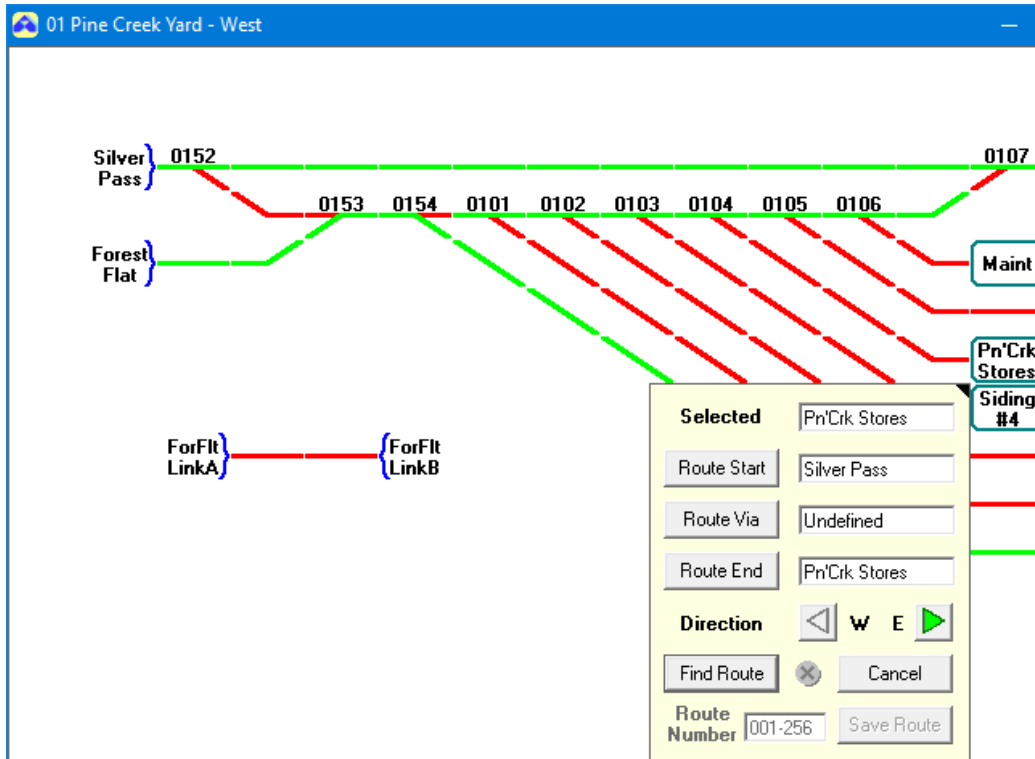

Click on **Find Route** to start the route search process which, in this case will succeed and display a green tick mark (✓) next to the **Find Route** button, whose caption will now change to **Run Route**. You may note that the caption on the **Cancel** button has also been changed to **Close** –

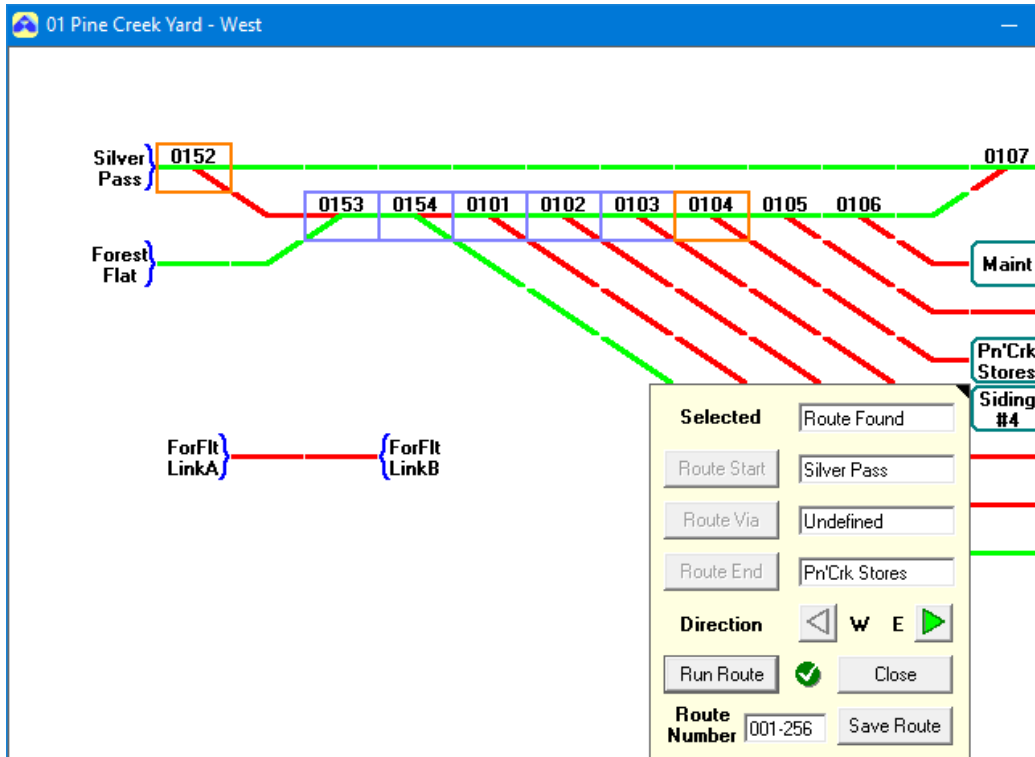

You will also note that all turnouts which lie on the found route are highlighted. Turnouts which require to be set in the Normal (straight) direction are highlighted in **mauve**, with those to be set in the Route (diverging) direction highlighted in **orange**.

Although all of the highlighted turnouts are clearly visible here, on some occasions they may lie underneath the Route Select window so that, although the highlight box(es) will be visible through the window, details of any such turnouts themselves are hidden. In these cases, the Route Select window can be removed simply by a click on any blank cell of the Mimic. A-Track retains all details of the found route, and the Route Select window can be redisplayed at any position on any of the current set of Mimic diagrams by a left-click on any Mimic cell with either **Ctrl** (Control) key held down.

To issue Accessory commands to set the direction of the highlighted turnouts (assuming that your NCE system is connected and operational) click **Run Route**. As the commands are issued, the Turnout elements and their connected Track elements on the Mimics will change colour to show their appropriate state (Open or Closed). The turnouts will also continue to be highlighted so that you can check that all of the selected turnouts get thrown in the correct direction, as shown below –

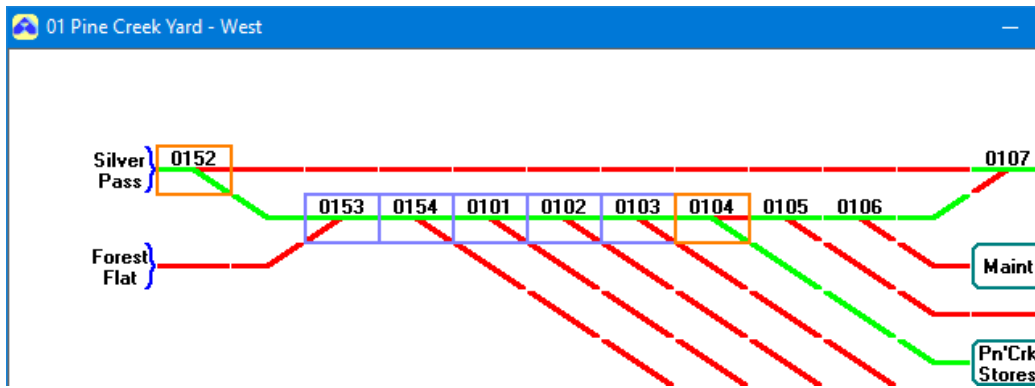

Note that A-Track queues all of the generated Accessory commands, to ensure reliable operation, so that there may be a delay of a few seconds before all of the real turnouts on your layout receive their appropriate command to move.

If you wish, you can save the found route as one or more Macros, whether you choose to run the route or not. If the route contains more than 10 turnouts then additional linked Macros will be generated as necessary (see **Section 7.9**).

To save the route, first enter a Macro Number into the **Route Number** textbox and then click **Save Route**. Clicking the Save Route button without entering a number for the destination Macro will display a warning message –

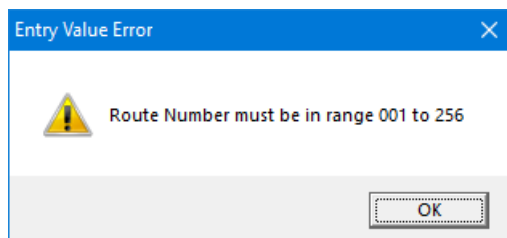

If a Route Macro Table is already open, and the selected Macro (and any of the following Macros which may be required) is not empty, ie. already contains Accessory commands, a further warning will be displayed –

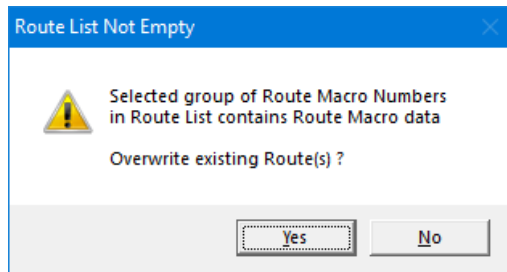

Clicking **No** is the safe option, unless you are sure that the existing Macros are not required, and you can then enter a different **Route Number** in the Find Route window, and try again. Otherwise, click **Yes** to replace the existing Macros with the newly-found route.

If no Route Macro Table is open then, after entering '20' into the **Route Number** textbox and clicking **Save Route**, a new (empty) Route Macro Table is displayed, and is then populated with one or more new Macros representing the found route –

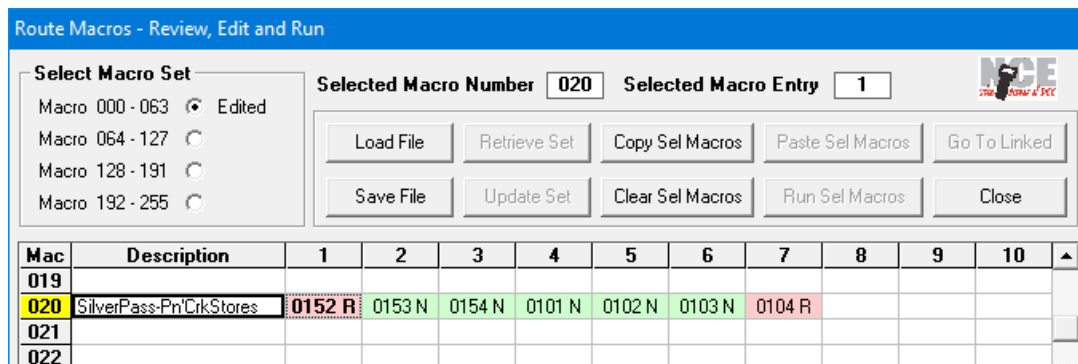

The Macro Description is generated by combining the Route Start and Route End text labels. Since the concatenated text will often exceed the allowed 24 characters, you may then need to edit the Macro Description as described in **Section 7.7** to reduce it to the permitted length.

You should then save the updated Route Macro Table contents as a Route List file. However, if you neglect to do this straight away, a reminder will be displayed as usual when you eventually attempt to close A-Track –

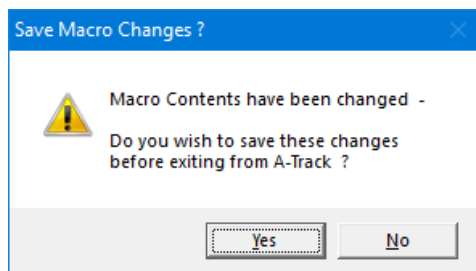

Note : A-Track does **not** keep a permanent record of the route finding operation automatically, nor of the last route found. Saving the found route to a set of Macros is the only way of preserving this information.

When you are happy that the required route has been set correctly in your Mimic diagrams, or you wish to abandon the current operation, click the **Close** button in the Route Select window to remove all turnout highlights and the Route Select window itself.

When finding a route between two points, you can exert a little more control over the path taken by using the **Route Via** button in the Route Select window to pick a Mimic element through which the route is constrained to pass. As a simple example, consider the route between the 'Forest Flat' Link element and the 'Siding #2' Terminal -

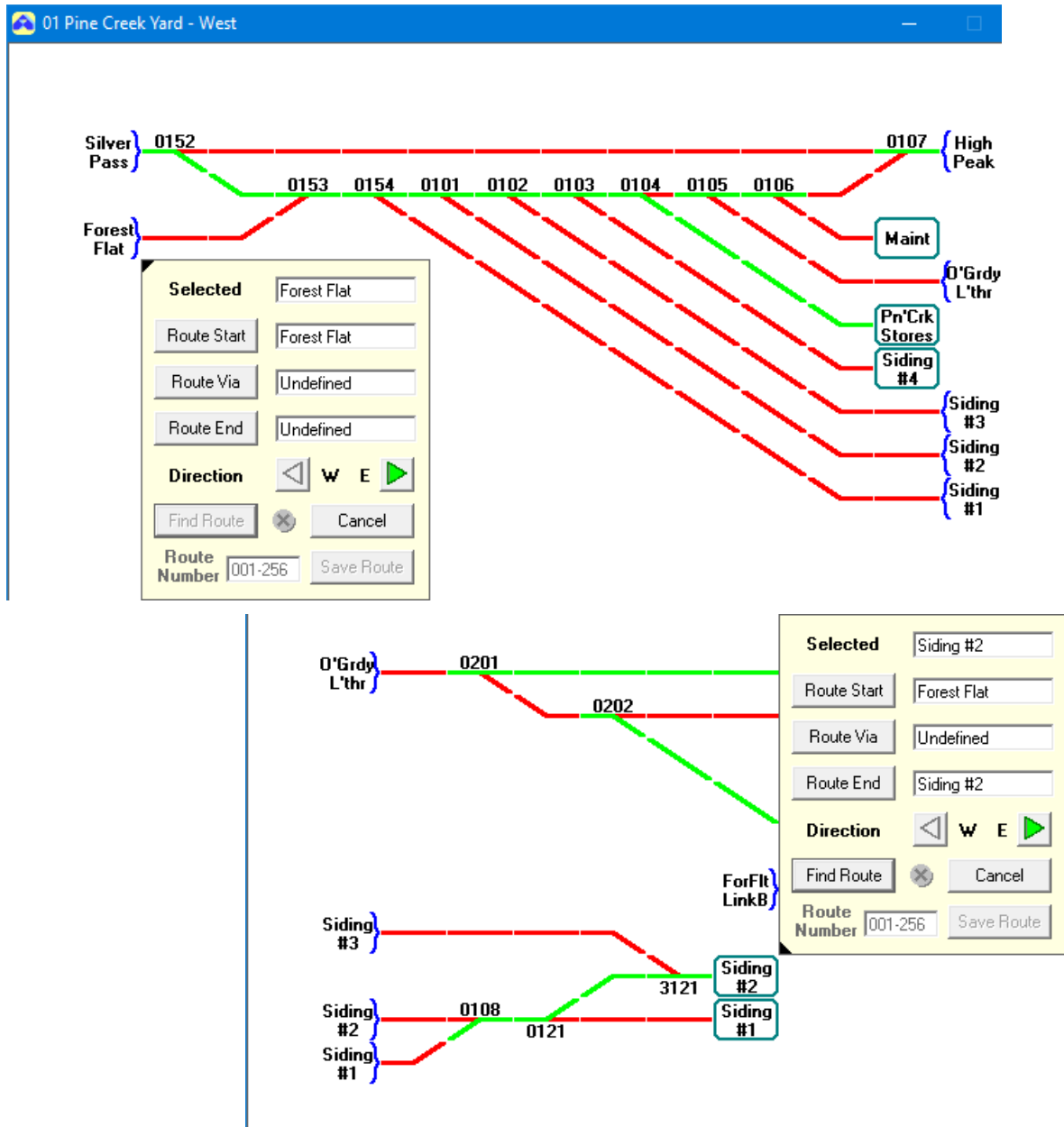

Finding a direct route (without a via point selected) produces the result shown below, with five turnouts highlighted with settings to use Siding #3 as the path -

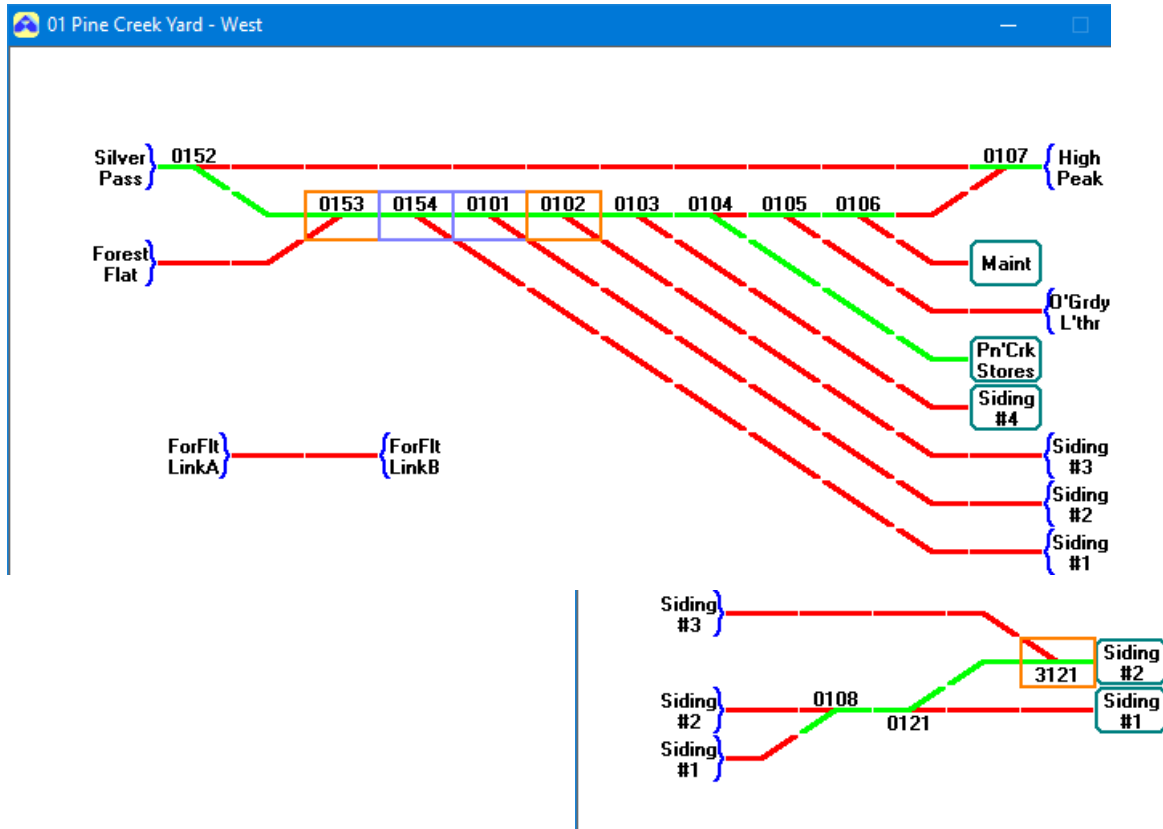

However, if before clicking the **Find Route** button, we left-click on one of the Siding #1 Link elements with a **Ctrl** (Control) key held down, to open the Route Select window, a click on **Route Via** will select Siding #1 as the desired route midpoint -

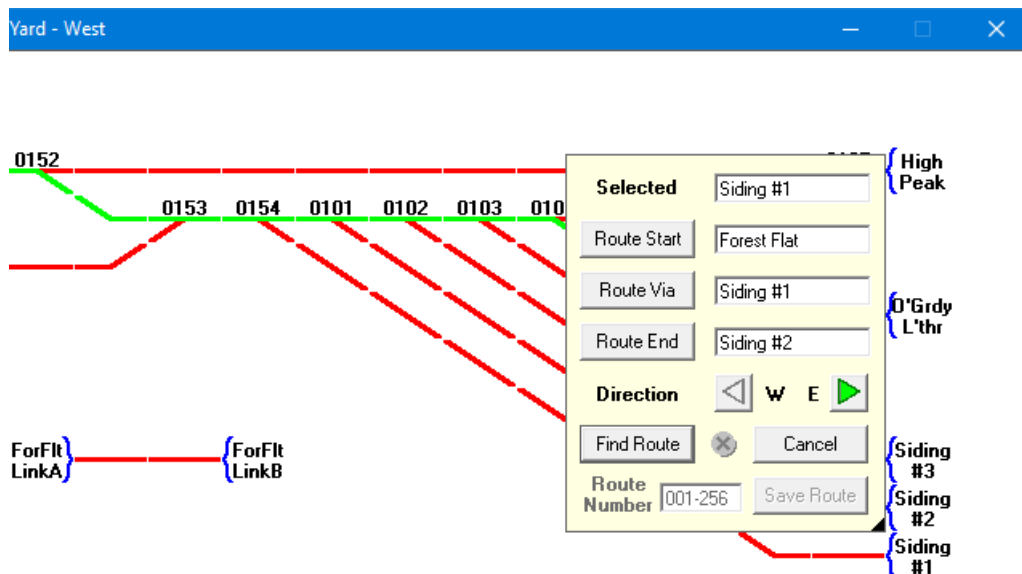

Click **Find Route** to generate the alternative route using Siding #1 -

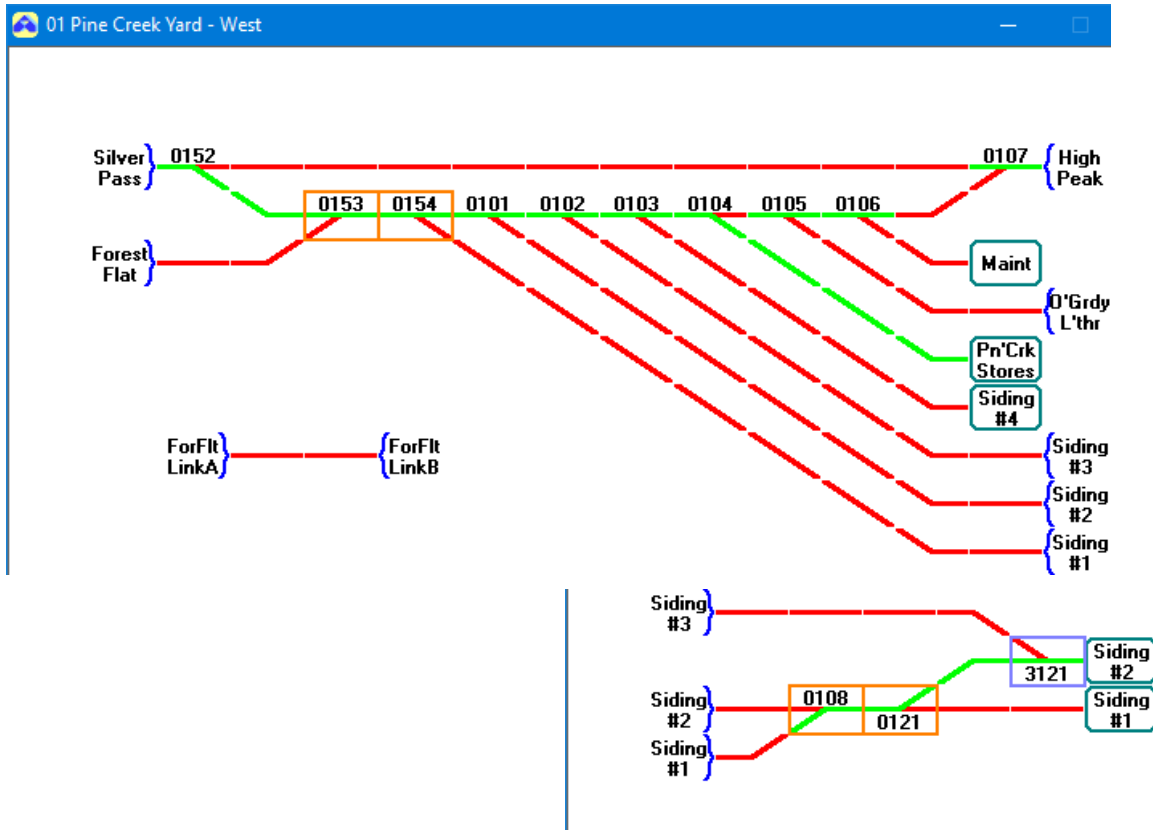

You can now click **Run Route** to issue commands to set the selected turnouts, and save the found route as a Macro, if required.

As well as identifying the relatively short, straightforward routes shown so far, A-Track can also find longer routes involving, perhaps a full circuit, or more, of the complete layout. As an example, we can search for a path between 'Gregson Silver Siding #1' and 'McGilligan Lumber North Siding' Terminal elements –

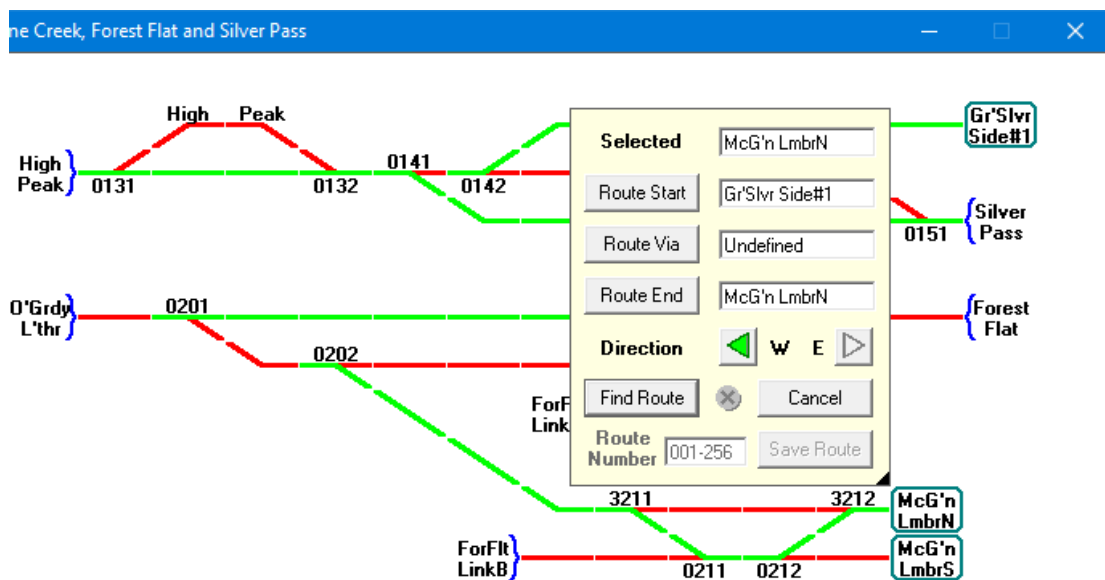

As the search proceeds, progress is shown in the Route Select window by a display of the current iteration number in the **Selected** textbox (for those who may be interested, A-Track uses a variant of Dijkstra’s Algorithm for pathfinding). Because many layouts involve a continuous loop, searching for a route could continue indefinitely, so the number of iterations is limited to 4096, after which the search will be stopped. In this case, a route is found after a few hundred passes –

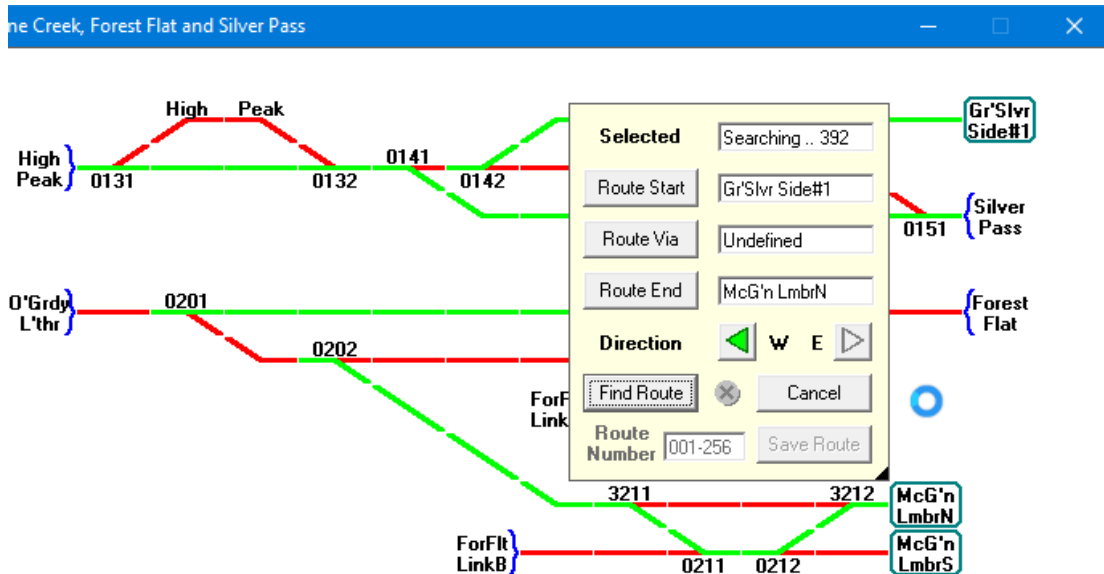

When the turnouts involved in the route are highlighted, you will see that several are obscured by the Route Select window, although the highlighting rectangles are clearly visible –

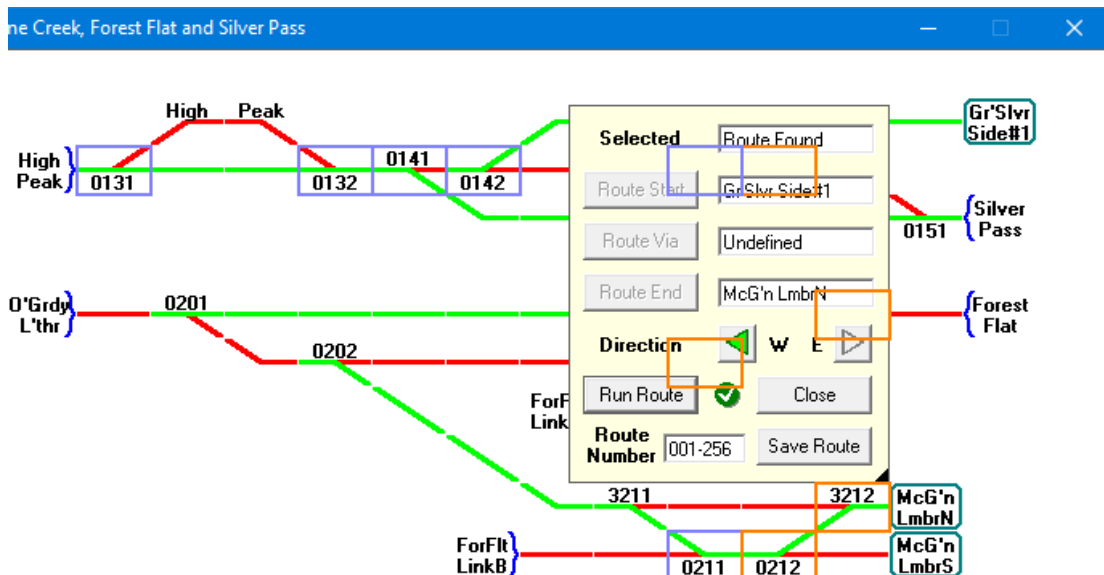

Either remove the Route Select window completely by a simple click on any Mimic cell, or move it to another area of the Mimic diagrams by holding down a **Ctrl** key while clicking in a suitable Mimic cell –

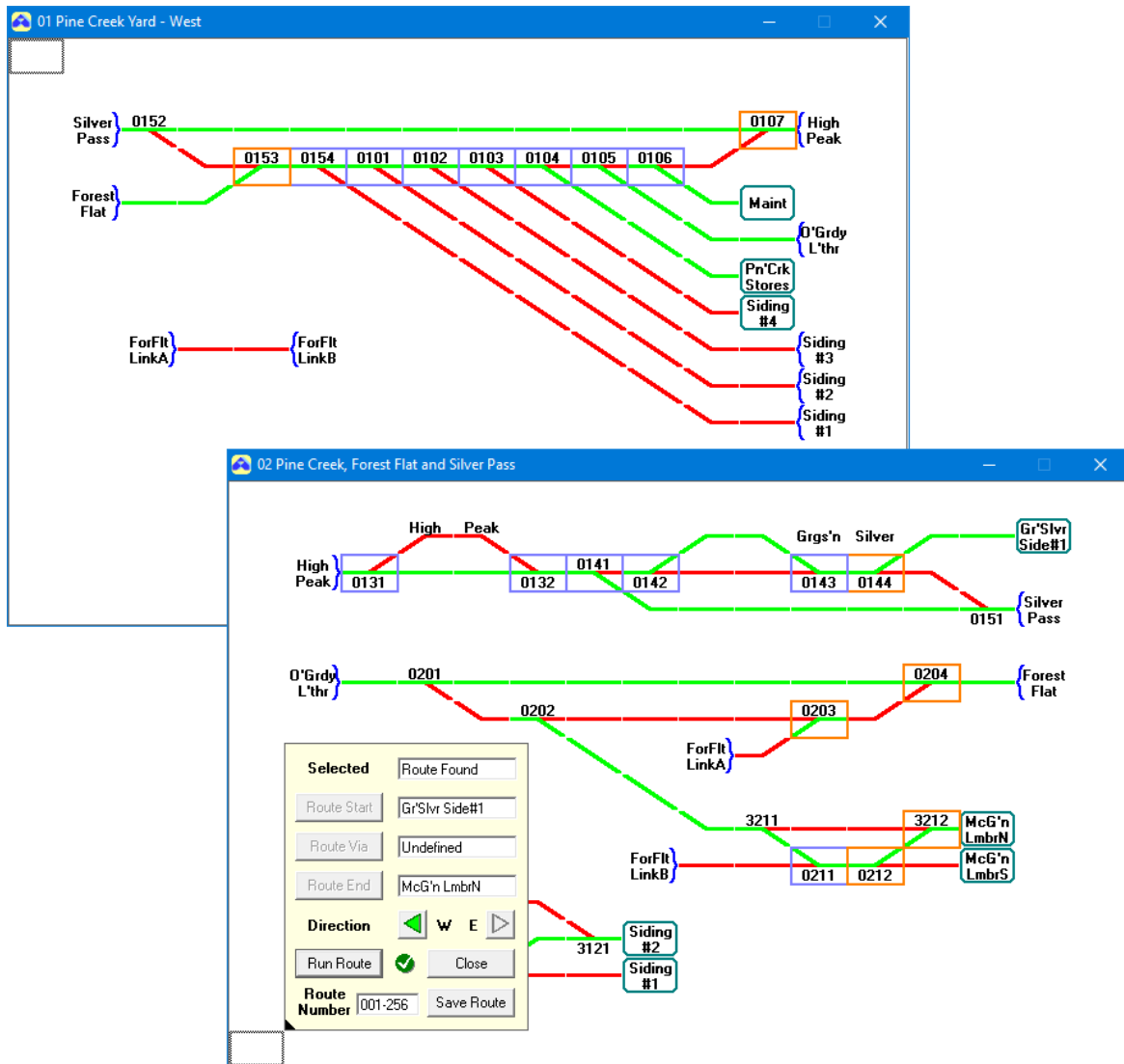

Remember that, if you are using a smaller screen which will only allow one Mimic panel to be fully visible at a time, that you can use the 'C' and 'T' keys to switch between **Cascade** and **Tile** presentations (see **Section 8.1**). **Cascade** mode will allow you to bring any Mimic panel to the front of the screen by clicking on any visible part of the panel. Alternatively, **Tile** mode will display only a single Mimic panel at a time on the screen, and you can then use the 'D' (Down) and 'U' (Up) keys to scroll through the Mimic Set panels in numerical order.

The found route in the example above involves setting the directions of 20 turnouts so that, if you choose to save the route as a set of Macros, by entering a Route Number and then clicking Save Route, it will occupy three Macros as shown below –

Mac	Description	1	2	3	4	5	6	7	8	9	10	
019												
020	GrSlvrSide#1-McGLmbrN1	0144 R	0143 N	0142 N	0141 N	0132 N	0131 N	0107 R	0106 N	0105 N	> 021	
021	GrSlvrSide#1-McGLmbrN2	0104 N	0103 N	0102 N	0101 N	0154 N	0153 R	0204 R	0203 R	0211 N	> 022	
022	GrSlvrSide#1-McGLmbrN3	0212 R	0212 R									

Note that Macro 022 consists of two identical entries, **0212 R**, since turnouts 0212 and 3212 are both driven from a single Accessory decoder output. Although the second entry is redundant, leaving it in place will not cause any problems when the relevant commands are sent to your NCE system.

When setting long routes such as the previous example, you can select a Via point as for shorter routes, but some care is required in its selection. Picking the High Peak passing siding, for example, by selecting either of the Track elements labelled 'High' or 'Peak', will not cause any problems – turnouts 0131 and 0132 will simply be set in the Route direction rather than as Normal.

However, if you selected the Link element labelled 'O'Grdy L'thr', which looks as though it would lie on the final route, then the route-finding process will fail with the warning message shown below –

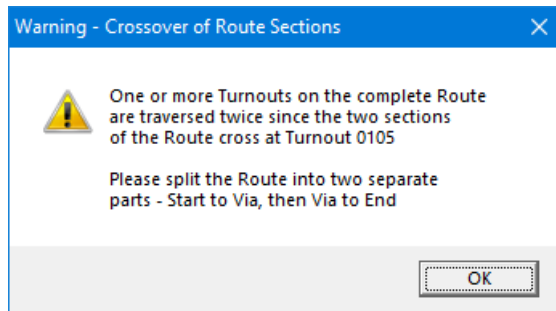

A-Track first finds the route from 'Gregson Silver Siding #1' Terminal element to one of the 'O'Grady Leather' Link elements, which will involve, as part of the route, setting turnouts 0106 through 0101 in the Normal direction, while making a complete circuit and a half of the layout. A-Track then finds a route from the 'O'Grady Leather' Link element to the 'McGilligan Lumber North Siding' Terminal element, which begins with a requirement to set turnout 0105 in the Route direction, in conflict with the first section of the route. Route finding is then halted with the above warning.

Click **OK** to dismiss the message, and note that the Route Select window now shows 'No Route Found' in the Selected textbox, with a red cross (⊗) displayed next to the **Find Route** button, although, as stated in the warning message, *separate* routes could be defined from Start to the Via point and from the Via point to the End –

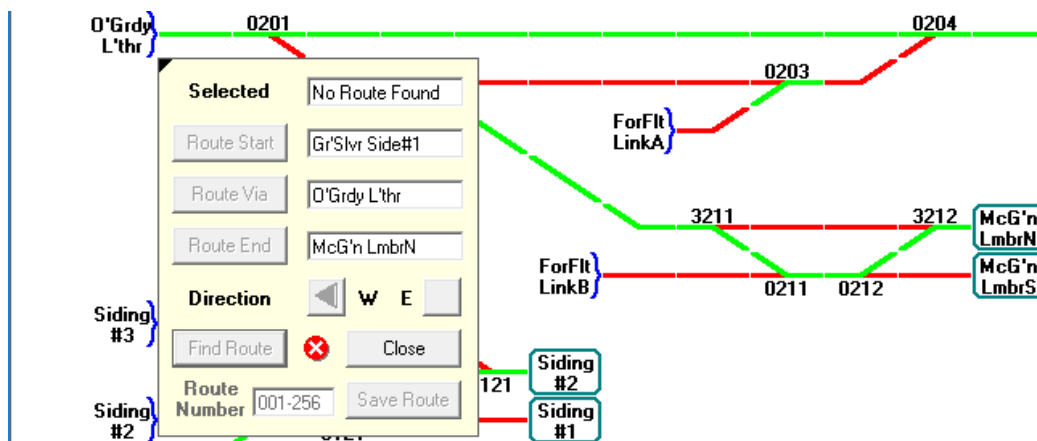

Click **Close** to clear details of the failed route-finding operation.

A similar situation can arise if the layout in question includes a **reverse loop**, such as in the small layout shown below –

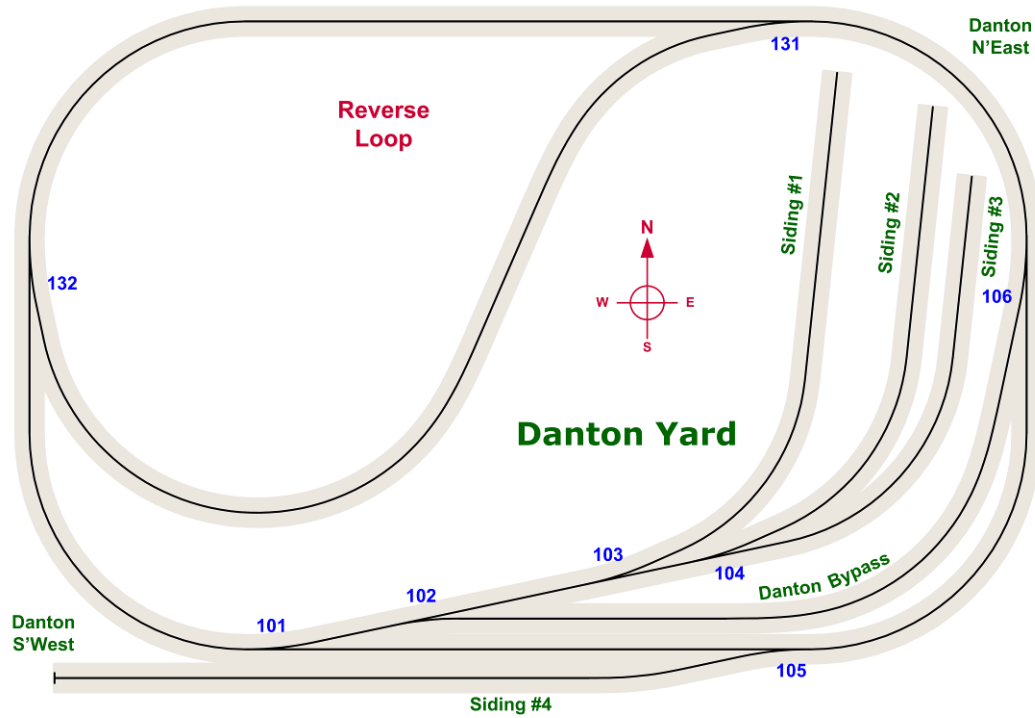

The layout can be represented in a pair of Mimic panels –

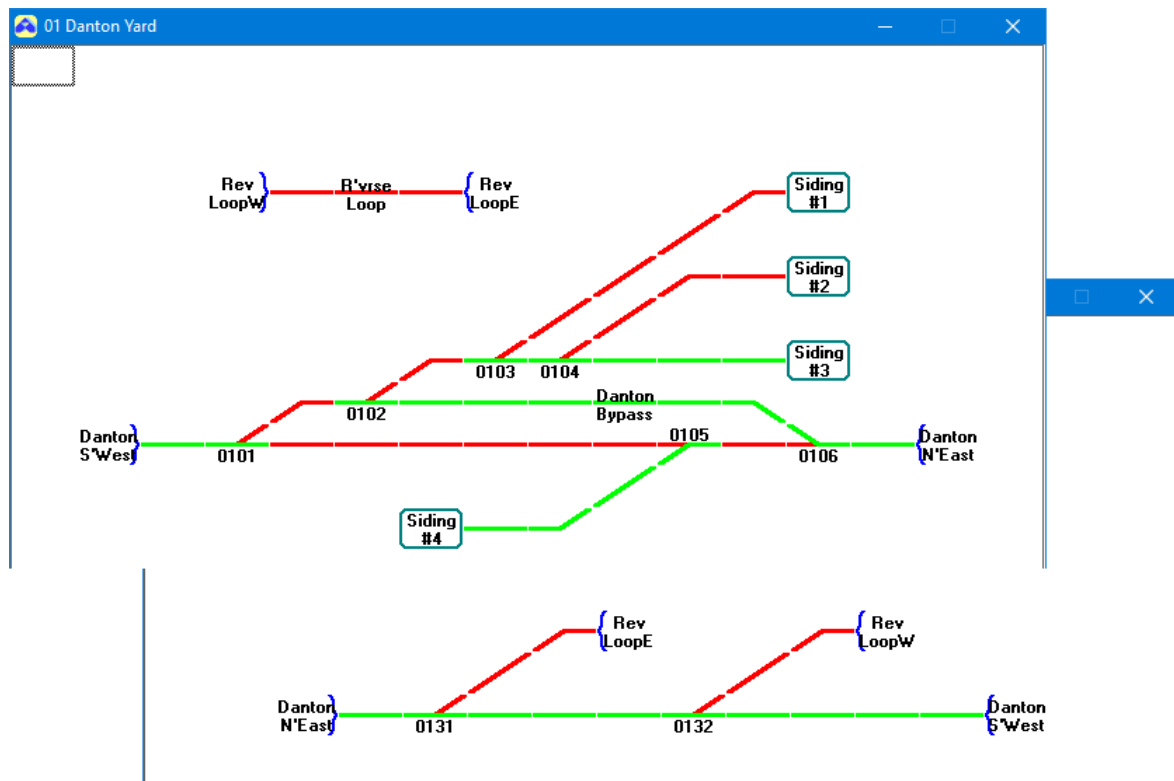

Finding a route from the entrance to the yard at Danton SouthWest to Siding #4 will involve using the reverse loop –

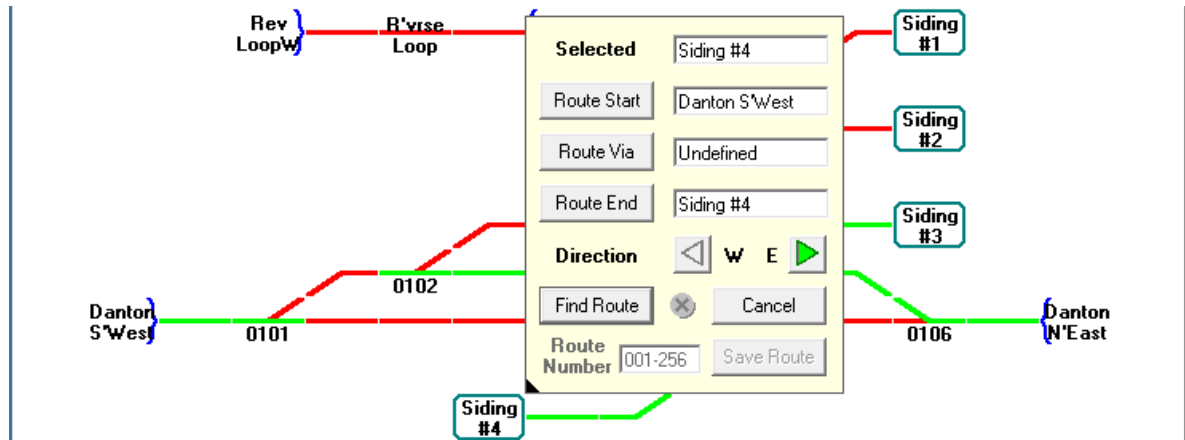

– and will produce a warning message –

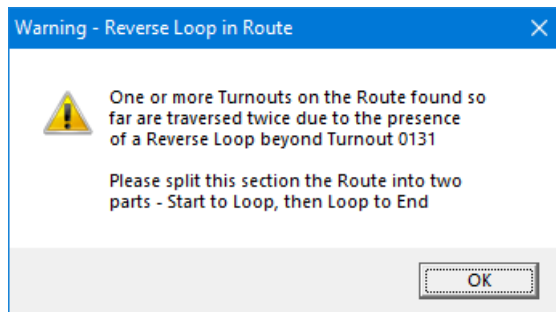

Taking the advice from the message, and splitting the route from Danton SouthWest to Siding #4 into two parts, yields the following result for the first section –

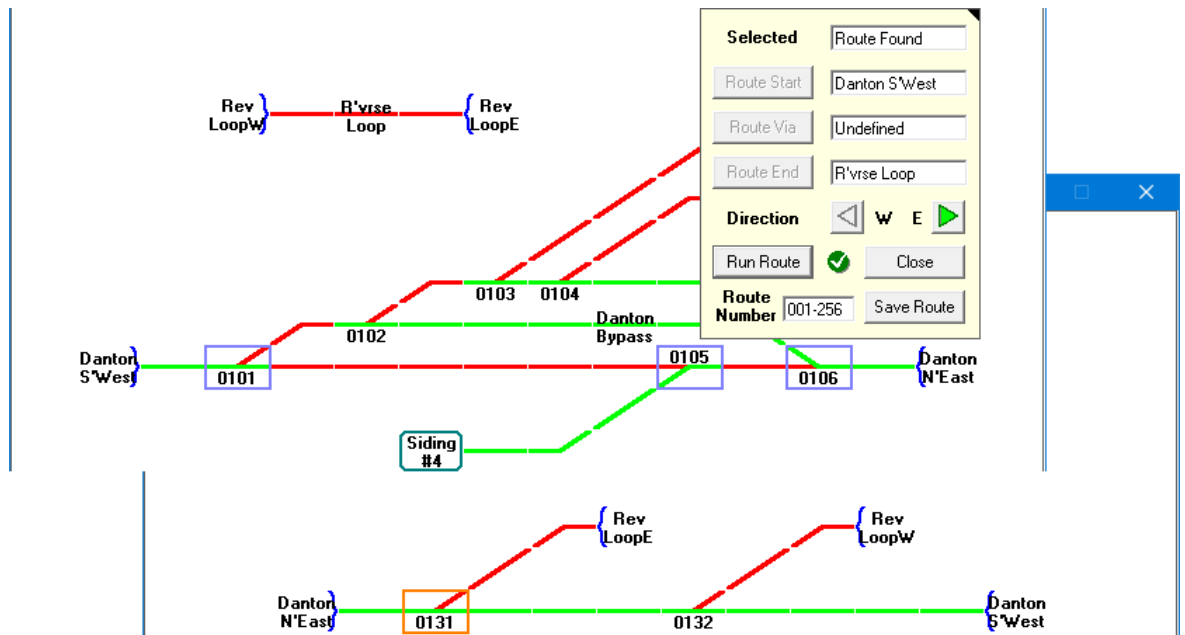

- which gets a train into the Reverse Loop, from which we can then find a route into Siding #4 -

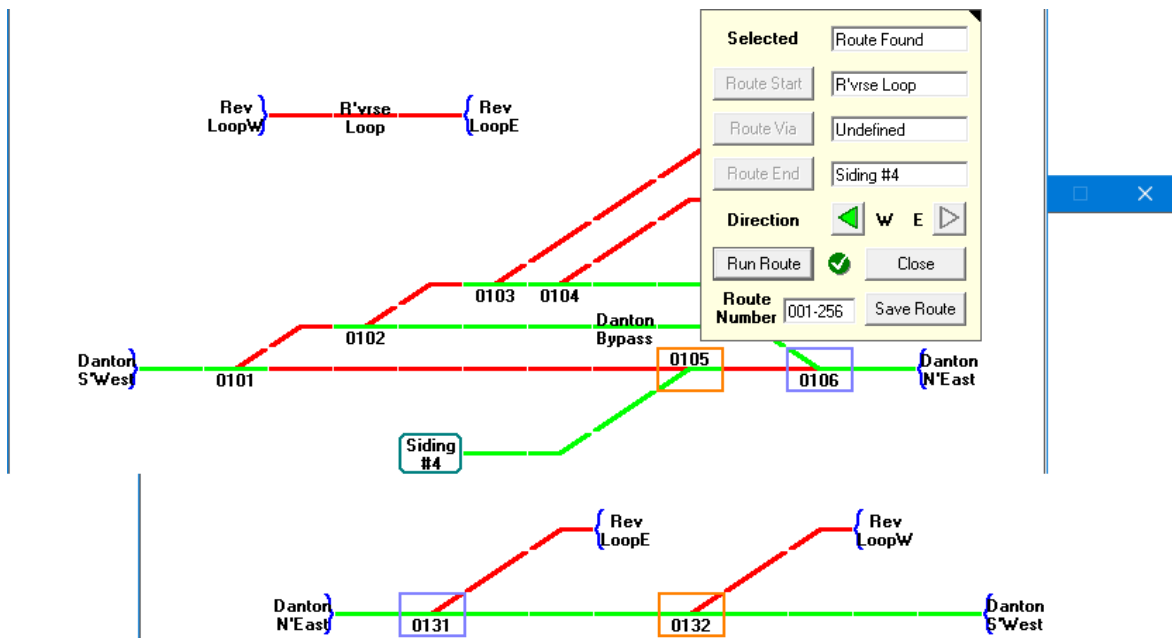

Note that this route, returning from the Reverse Loop, requires the directions of turnouts 0131 and 0105 to be changed from that of the entry route. This switchover is a requirement of traversing any reverse loop in a layout, so that such manoeuvres cannot be done using a single, unidirectional route.

8.6 Using Mimics with 'Single-Click' Settings

When setting routes or individual turnouts on your layout, you may find it more convenient to handle the relevant Mimic diagrams by using single left-clicks with the mouse (or single taps if using a touch-sensitive screen) without the requirement to hold down a Control (**Ctrl**) or Shift (**⇧**) key at the same time. Three options are provided via the Mimic menu, or by using Toolbar icons -

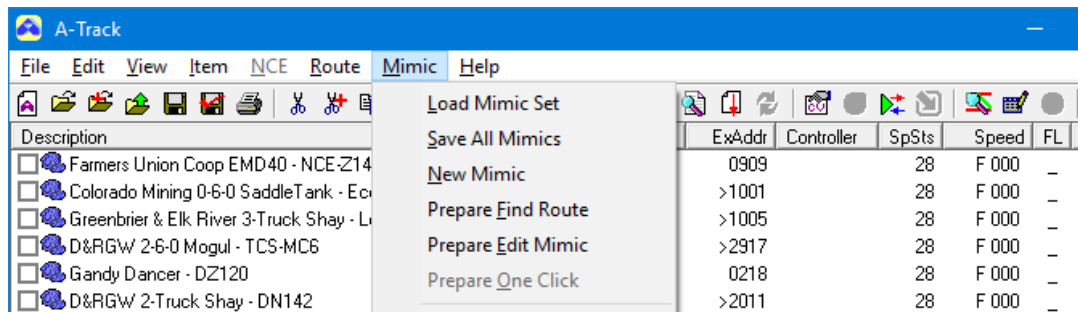



The second option, **Prepare Edit Mimic**, is only available when there is no connection to the NCE Command Station (or the Command Station is not switched on), and a Set of Mimic diagrams has been loaded. Conversely, the third option, **Prepare One Click**, is only available when there is a connection to the NCE Command Station.

Selecting **Prepare Find Route** by clicking either the option on the Mimic menu or the  icon on the Toolbar, allows you to display the Route Select window (see **Section**

8.5) and to select Mimic cells as Route Start and End points, with a single left-click of the mouse instead of having to hold down a Control (**Ctrl**) key on the keyboard while clicking a relevant Mimic cell.

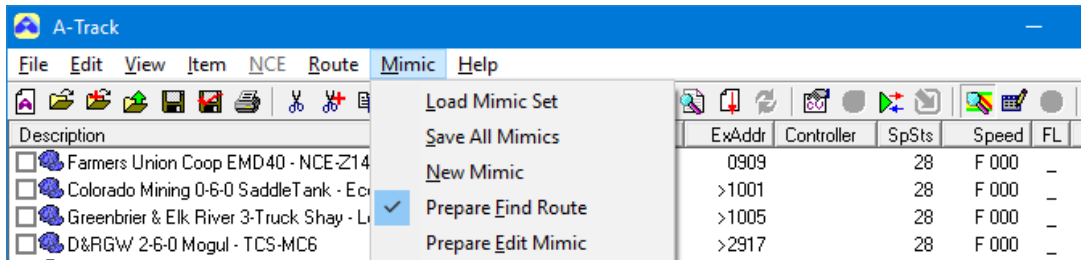
When the **Prepare Find Route** option is selected, the menu option is checked (ticked) and the Toolbar icon changes to the active version,  –



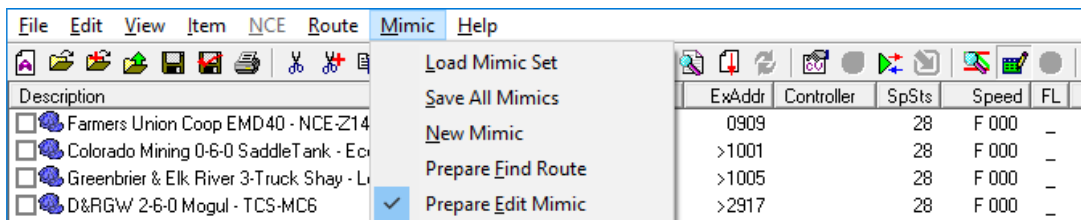

Alternatively, you can select the **Prepare Edit Mimic** option by a click on the Mimic menu, or on the  Toolbar icon. Note that, when you do this, the **Prepare Find Route** option will be disabled since only one 'single-click' option can be active at any given time as can be seen below with the **Prepare Edit Mimic** option checked (ticked) and the Toolbar icon changed to the active version,  –



The **Prepare Edit Mimic** option allows you to open the Mimic Edit window (see **Section 8.1**) with a left-click (or tap on a touch-sensitive screen) as well as with a right-click of the mouse. Note that you can only edit single Mimic elements using this option on its own. Selecting a block of elements as described in **Section 8.2** still requires the use of a Shift (**↑**) key when clicking a selected Mimic element or cell.

The third option, **Prepare One Click**, is only enabled when a Mimic Set is loaded and A-Track is connected to the NCE Command Station. In this situation, although **Prepare Find Route** is still available, **Prepare Edit Mimic** is disabled, since Mimics cannot be edited when connected to an active NCE System.

When **Prepare One Click** is made active by selection from the Mimic menu or a click on the  icon on the Toolbar, it allows you to change the state of any turnout on a Mimic panel with a single left-click instead of a double-click (see **Section 8.3**). In this state, the Mimic menu option is checked (ticked) as usual, and the Toolbar icon changes to the active version,  –

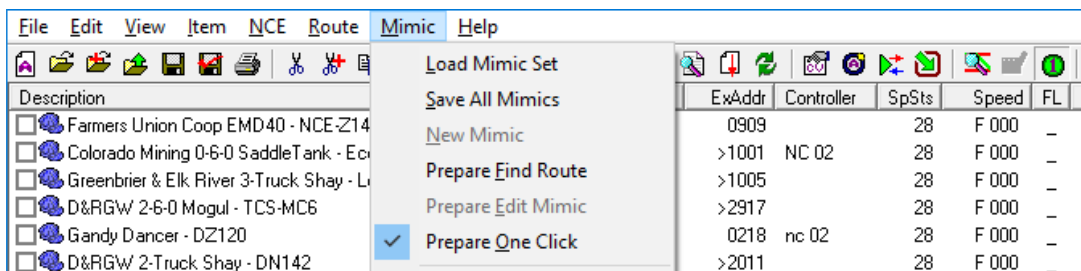

9 NCE COMMAND STATION AND CAB OPERATIONS

As well as helping you to manage and maintain your roster of DCC locomotives and accessories, A-Track provides a number of facilities to assist you in the configuration and handling of the NCE System equipment, together with its associated stored data and parameters. The NCE Power Pro System has the widest range of configurable parameters, with a more limited set available when using NCE Version 1.65 Power Cab, Smart Booster, or DCC Twin Systems. The facilities are not available with the older Version 1.28 Power Cab and Smart Booster (SB3) Systems.

The basic NCE Power Pro System depends for retention of all of the system data stored in the NCE Command Station, including your set of operational preferences, on a small coin cell (battery) fitted internally, and which must be replaced periodically. While this generally works very well, there is still a risk that this data and your settings can be lost inadvertently, requiring you to re-enter everything again by hand – hopefully from notes that you have kept of your original settings.

Using A-Track, not only can you see all of your operational settings in the Command Station at a glance, but you can also save all of these settings to files on the hard disk of your computer – from which you can restore them to the Command Station at any time. This also applies to the parameters and locomotive allocations associated with each Handheld Cab, and to your defined sets of Consists and Macros.

While the NCE Power Cab, Smart Booster, and DCC Twin Systems use non-volatile internal memory to retain their system settings rather than a battery, and allow most of these settings to be downloaded and saved to files, they impose some restrictions on how this data can be restored. When system settings are restored to an NCE Power Pro System, the restored values are retained even when the Power Pro is switched off. However, this is not the case for NCE Power Cab, Smart Booster, and DCC Twin Systems which (as the result of an NCE design flaw) will not transfer the restored data to their internal non-volatile memory. You will, therefore need to restore your saved settings each time the System is switched on. A-Track allows you to do this automatically as soon as the program is started and connected to an appropriate Power Cab, Smart Booster, or DCC Twin System.

Access to these facilities is available via the **NCE** menu, which is only enabled when an appropriate NCE Command Station is connected to A-Track, and operational –

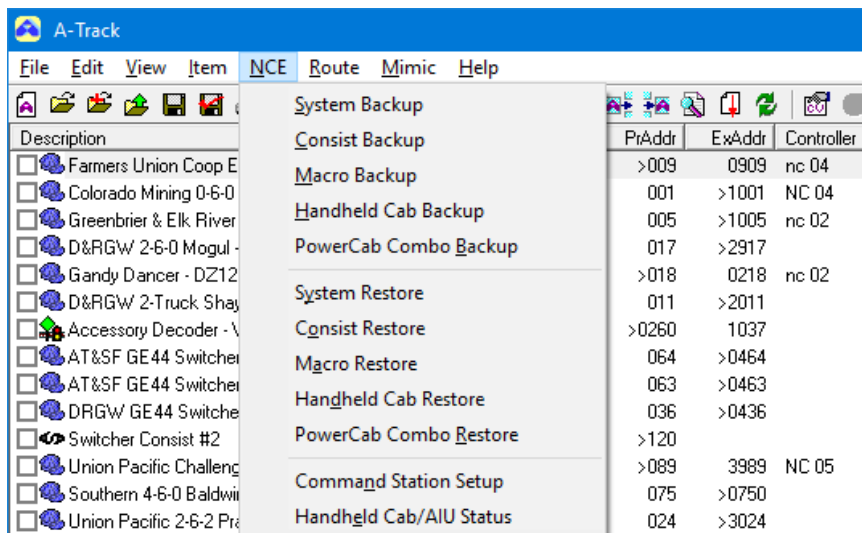

The first section of the menu allows you to select one of four areas of the NCE Command Station memory and to copy its contents to a backup file on the PC. Any of these backup files can then be used in the future, via the second set of menu options, to restore the corresponding area of Command Station memory to the state it was in when originally saved to the file. The fifth option in the first section allows you to save all memory areas of a Power Cab, Smart Booster, or DCC Twin Command Station to a single, combined backup file, and you can later use the fifth option in the second section to restore all of the Command Station memory to a defined state. This Combo Restore operation can be automated so that the Command Station status is restored to a known state as soon as A-Track is started (see **Section 9.1**). The Combo Backup and Restore options are disabled when an NCE Power Pro System is connected to A-Track.

You can save as many different variants of your settings, allocations, and assignments (corresponding to different operating sessions, for example) as you like, and A-Track allows you to swap them in and out of the Command Station from the attached PC at any time. You are, of course, not restricted to keeping these data files only on the PC's hard disk, but can just as easily write them to a USB flash drive (memory stick), or to CD or DVD for secure, permanent storage.

The last two options on the **NCE** menu will give you an immediate view of how the Command Station and any attached Handheld Cabs or Auxiliary Input Units (AIUs) are currently configured, and then allow you to adjust a range of these settings to your own preferences.

Note that, when the full status of all attached Handheld Cabs, and their allocations in the Item List, are being refreshed automatically (every 6 minutes, if that option is set), or manually, the NCE menu is disabled in order to avoid any conflicts in accessing the Command Station. If this refresh interferes with your backup or setup operations, for example, it can be stopped, as described in **Section 3.5**, by using the **Refresh Item Allocation & Status** option on the **View** menu, or the Refresh icon () on the Toolbar.

The polling of individual attached Handheld Cabs and AIUs which occurs automatically every 2 seconds, as described in **Sections 6.8** and **8.4**, does not interfere with any of the backup, restore, or setup operations.

9.1 Command Station Data Backup and Restore

When performing any backup operation, and particularly a backup of NCE Handheld Cab parameters, you should not operate any of the Handheld Cabs, so that the Command Station is not active in generating any new DCC commands.

From the **NCE** menu, click on **System Backup** to transfer the current System settings from the Command Station to A-Track. These settings include those for the System (Fast) Clock, allowed operations by Handheld Cabs, and locomotive Momentum amongst other parameters which, for a Power Pro System, include the Serial Port Baud Rate. The transfer only takes a second or two to complete, and you will get a short glimpse of the normal data transfer progress bar.

A standard **Save As** window will then open, requesting you to choose a destination folder for the copied System data. In the example shown below, a new folder to hold backup files has been created within the principal Documents folder. Click **Open** to open the new folder (or select an existing folder by double-clicking on it) –

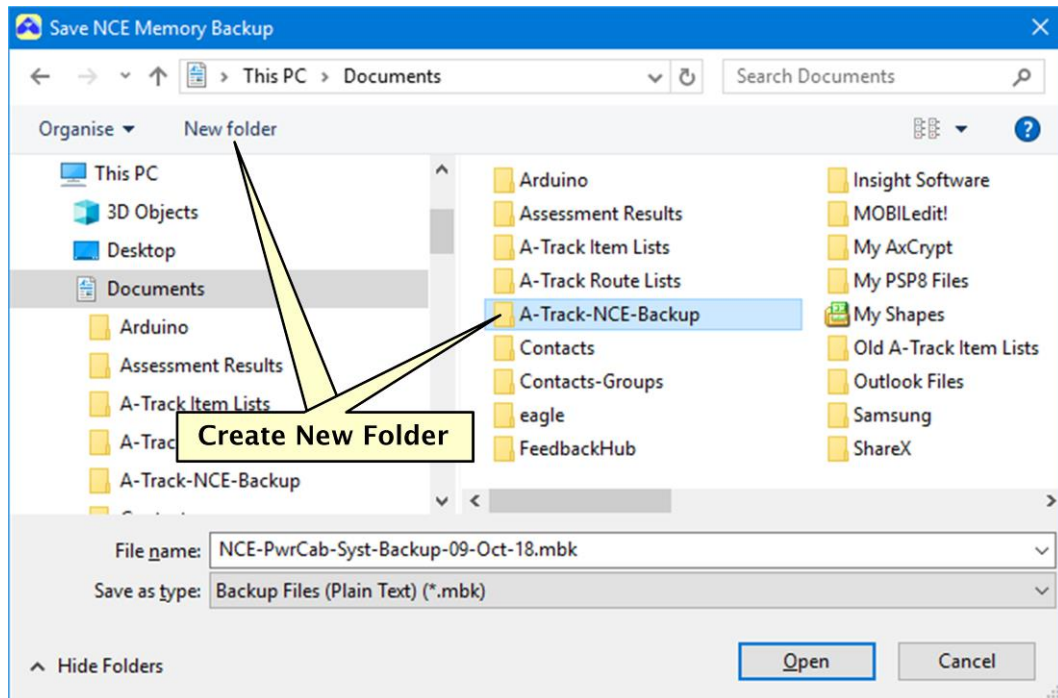

A-Track, as you can see above, provides a suggested filename (**NCE-PwrCab-Syst-Backup-09-Oct-18.mbk**) showing the type of system and backup data together with today's date. However, you can edit this suggestion as much as you like in order to give this particular set of system parameters a description appropriate to your own layout or the operating session to which they apply.

When you are happy with the filename, click **Save** to save the backup file to the selected folder, after which the System Backup operation will be confirmed by an acknowledgement –

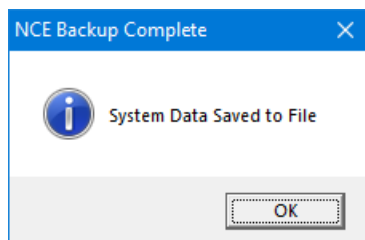

Click **OK** to continue.

Backup of the set of Consists stored within the NCE Command Station is performed in exactly the same way, by clicking **Consist Backup** on the **NCE** menu. Because of the larger quantity of data to be copied, the transfer takes longer than that of System data, requiring between 5 and 10 seconds to retrieve all Consist data, so you will see the data transfer progress bar –

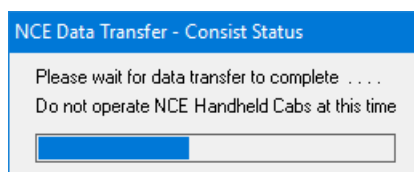

After the transfer completes, you can select the destination folder and filename for the retrieved Consist data in the **Save As** window which opens, as described previously. After saving the data, the result should be a couple of backup files such as those shown in the example below –

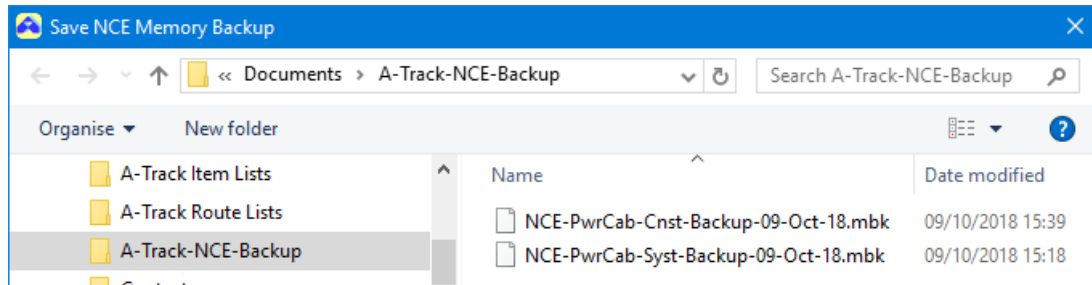

Note that all backup files (using the suggested filenames) incorporate the date of creation, and are given the file extension **.mbk** to identify them as Command Station memory backup files. They are, in fact, simple text files, and you can easily view their contents using any text editor such as Notepad. Each row in the file starts with the hexadecimal address from which the row's 16 data bytes (or 20 bytes for Macro backup files from a Power Pro System), also in hexadecimal, were copied. However, you are strongly advised **not** to edit the files directly, since any inadvertent change in the file structure (as well as in its contents) could disrupt Command Station operation when the data from such an edited file was restored to the Command Station memory.

Making a backup of the current status and allocations of Macros and of the Handheld Cabs is started, as for other backup operations, by clicking either **Macro Backup** or **Handheld Cab Backup**, respectively, on the NCE menu. For NCE Power Cab, Smart Booster, and DCC Twin Systems the operation proceeds as described above although, despite the quantities of Macro and Handheld Cab data being relatively small, the transfer will take an appreciable time because of the limited capability of the available transfer commands, compared to those available in a Power Pro system. For example, performing a Handheld Cab backup the transfer will take around 65 seconds when using a Smart Booster, and up to 90 seconds for the DCC Twin.

Although otherwise similar, the Macro and Handheld Cab backup operations for Power Pro Systems require an additional step to select a specific set of either Macros or Cabs.

Macro backup files for Power Pro systems contain a selected set of 64 macros from the total of 256 Macros that can be stored in the NCE Command Station. Clicking on **Macro Backup** from the NCE menu will display a simple form to allow you to enter the number of the first Macro in the set you wish to copy to a file –

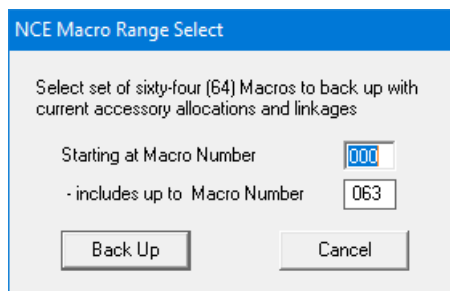

If you want to back up Macros other than the first set of 64 (000 to 063), you can enter any number in the highlighted textbox from 0 up to 192 for the first Macro, and the number of the last Macro will then be confirmed in the lower textbox. A-Track will not allow you to enter a first Macro Number greater than 192. If you attempt to do so, the starting number will be reset to 192.

When you have the required set of Macros selected, click **Back Up** to continue. The normal data transfer progress bar will be displayed, with the Macro backup transfer operation taking between 5 and 10 seconds, followed by the display of a **Save As** window to allow you to select (or create) a destination folder for the backup file.

The suggested filename for a Macro backup file contains the range of Macro Numbers selected, as well as the date when the file was saved –

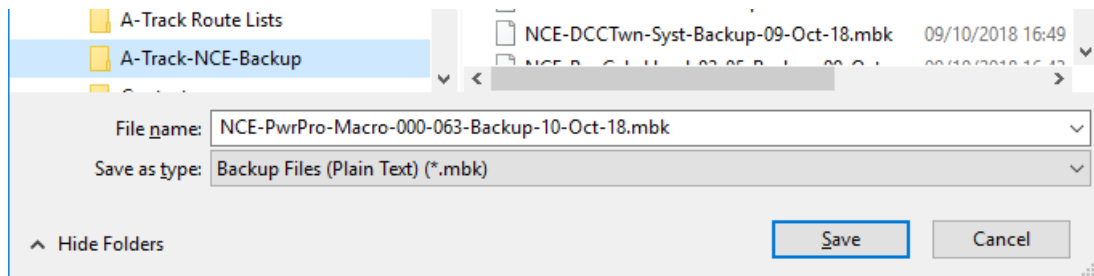

Again, you can edit or change the suggested filename as much as you like, perhaps to reference a particular operating session. After clicking **Save**, successful completion will be confirmed by a similar acknowledgement to that shown previously for System or Consist Backup.

Data for between one and eight Handheld Cabs attached to a Power Pro system can be saved in a single backup file, with the required range of Cabs selected using another simple form, displayed as shown below when you click **Handheld Cab Backup** on the NCE menu –

Enter the Address of the first Cab to back up in the lefthand textbox, and the Address of the last Cab of the backup set in the other textbox.

Cab Addresses can range from 01 to 63, inclusive, and the default set used by A-Track for the Power Pro starts at Cab 02 and finishes with Cab 09. If you only wish to back up the settings for a single Cab, then enter that Cab Address in both textboxes.

Attempting to select more than eight Cabs will result in an error message, and the Last Cab Address will then be set to (First Cab Address + 7) –

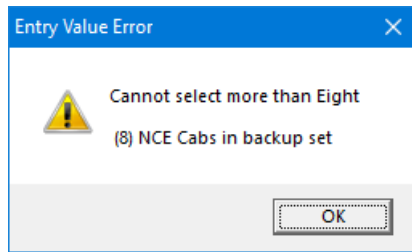

When you have the required range of Cabs selected, click **Back Up** to continue.

The normal data transfer progress bar will be displayed, with the Handheld Cab backup operation taking less than 10 seconds, followed by the display of a **Save As** window to allow you to select (or create) a destination folder for the backup file. The suggested filename for a Handheld Cab backup file contains the range of Cab Addresses selected, as well as the date when the file was saved –

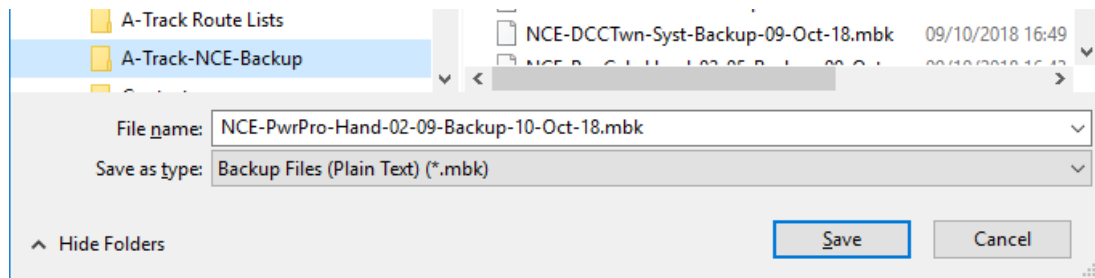

As before, you can edit or change the filename as much as you like, perhaps to reference a particular operating session, or an operator, or a specific allocation of locomotives. After clicking **Save**, successful completion will be confirmed by the usual form of acknowledgement –



It does not matter if the set of selected Cabs includes Cab Addresses which are unused. These inactive Cabs will be recorded with whatever parameters and allocations happen to be stored in the Command Station at the time.

You should, however, avoid creating backup sets of Cabs whose Addresses overlap since, when the files are restored to the Command Station, the parameters of Cabs in the overlapped range will depend on the order in which the files are restored.

This also applies to Macro backup sets where the ranges of Macros overlap, where the content of overlapping Macros will depend on which backup set is restored last.

If any error occurs during the transfer of any type of backup data to A-Track, then the whole transfer will be aborted, and the following prompt will appear –

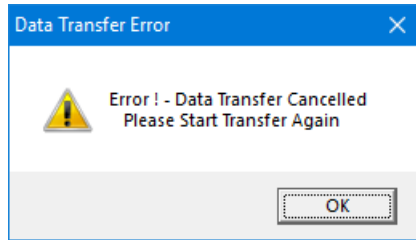

Click **OK**, then retry the failed backup operation again after checking that all cable connections are correct, the system has power, and that no other operations are active. If A-Track's communication with the Command System has been interrupted (one or more of the three indicators on the status bar, in the bottom righthand corner of the main A-Track window, are showing **yellow** or **red**) then you may need to wait up to 10 seconds for A-Track to re-establish communications and for the status bar indicators to turn back to **green**.

Once you have a set of backup files holding Consist or Macro data, you can use facilities within A-Track to review their contents. Macro Review and Edit functions are dealt with fully in **Section 7.7**, and the more limited functions available for Consist Review are covered in **Section 9.3**.

As mentioned in the introduction to **Chapter 9**, when using an NCE Version 1.65 Power Cab, Smart Booster, or DCC Twin System, any changes you make via A-Track to Cab Allocations, Consists, or Macros are not saved by the Command Station when it is shut down. The fifth option in the first section of the **NCE** menu is, therefore, provided to save all memory areas of a Power Cab, Smart Booster, or DCC Twin Command Station to a single, combined backup (Combo) file which can then be reloaded to your NCE System when it is next switched on to restore it to the same operational state.

Click **PowerCab Combo Backup** (or **SmartBooster Combo Backup**, or **DCC Twin Combo Backup**) to create the relevant combined backup file. The normal NCE Data Transfer progress bar will keep you informed as each group of data values is retrieved from the Command Station –

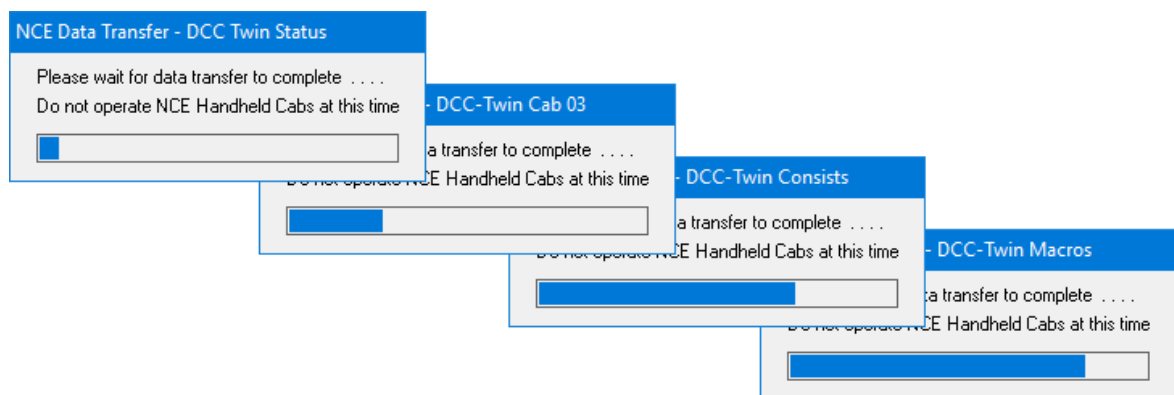

Since these Systems only allow data to be read 4 bytes at a time (compared to 16 bytes per transfer with a Power Pro), and are subject to some other limitations, the complete transfer will take around 40 seconds for a Power Cab, 50 seconds for a Smart Booster, and up to 60 seconds for the DCC Twin. Please be patient and resist any temptation to operate any Handheld Cab controls, or to access any other A-Track functions, while the data transfer is in progress.

When the transfer finishes, a **Save As** window will appear as usual to allow you to select (or create) a destination folder for the Combo backup file, together with a suggested filename which will have the extension **.cbk**, as shown below –

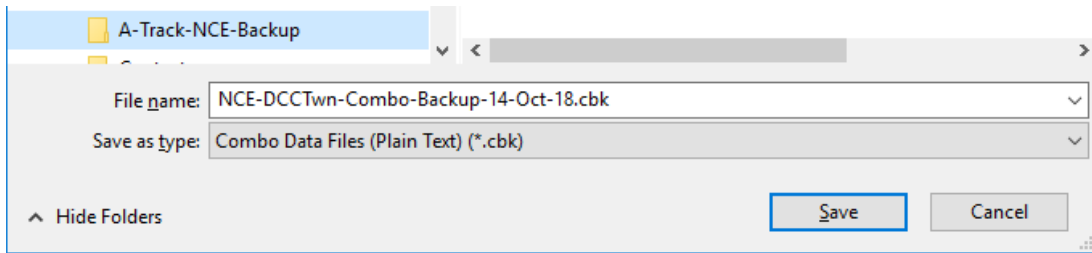

After editing the filename to suit your own preferences, click **Save** to save the file to your chosen folder. Whatever filename you decide to use, it is strongly recommended that you keep the **.cbk** extension to identify the file as a Combo backup file. Finally, click **OK** in the usual acknowledgement message –

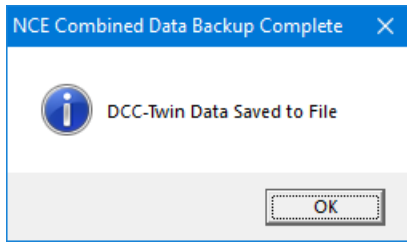

Restoration of the contents of a saved backup file to the NCE Command Station is reasonably straightforward, being essentially the reverse of the original backup operation. For example, to restore System parameters, click **System Restore** on the **NCE** menu to display a Restore NCE System Backup window –

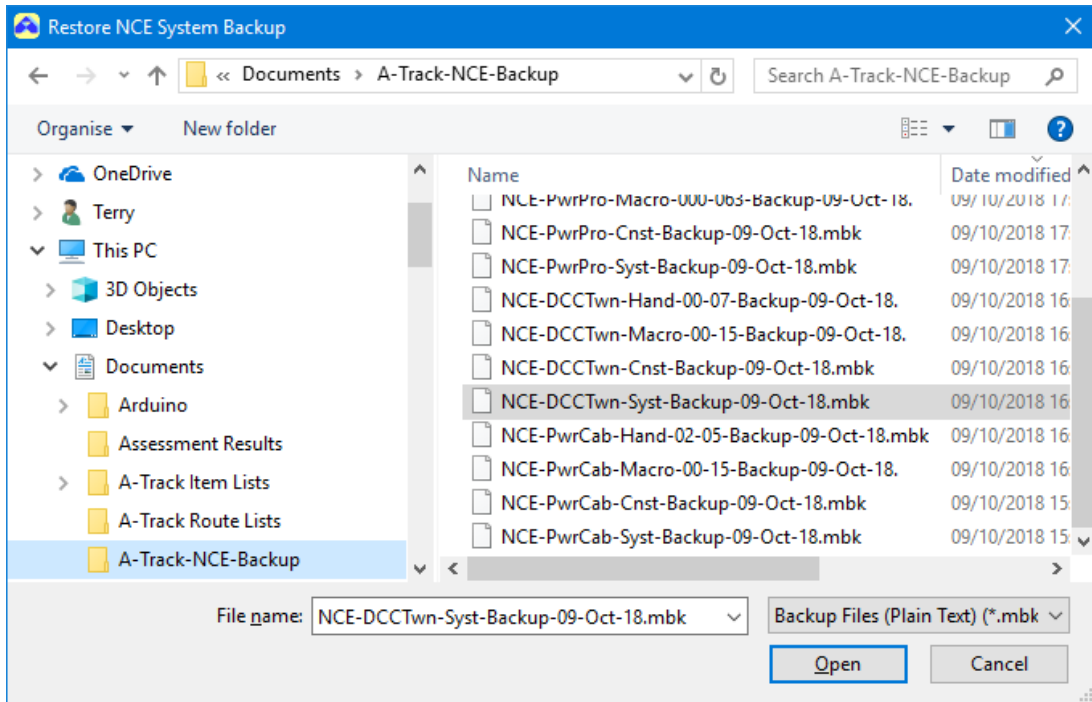

Select the appropriate folder and System backup file then either double-click on the file, or click the **Open** button. If, for any reason you select the wrong type of file, or the contents of the backup file do not match the expected set of parameters, then the restore process will stop, and you will see a warning message such as those below –

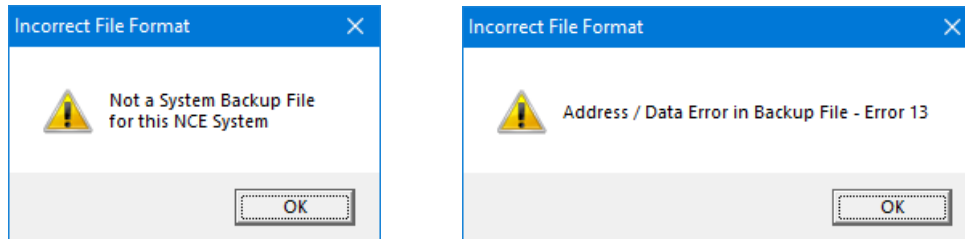

Click **OK** in to dismiss the message and to let you try again (although, if the problem is corrupt data, you need a detailed knowledge of the file structure to attempt a fix – help may be available via Support – see **Section 11.2**).

The System restore operation takes a little longer than backing-up the System parameters, but still only takes a few seconds to complete. You will see the normal data transfer progress bar before receiving confirmation that the System settings have been restored to their backed-up values –

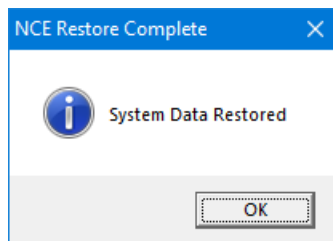

Restoration of the backed-up sets of Consists, Macros, or Handheld Cabs to the the NCE Command Station is performed in exactly the same way, by clicking **Consist Restore**, **Macro Restore**, or **Handheld Cab Restore**, respectively, on the **NCE** menu. However, before the Restore NCE System Backup window is opened to let you select the required backup file, a reminder will be displayed, such as that shown below, to ensure that all Locomotives are stationary on your layout and that no Handheld Cabs should be operated during data restoration –

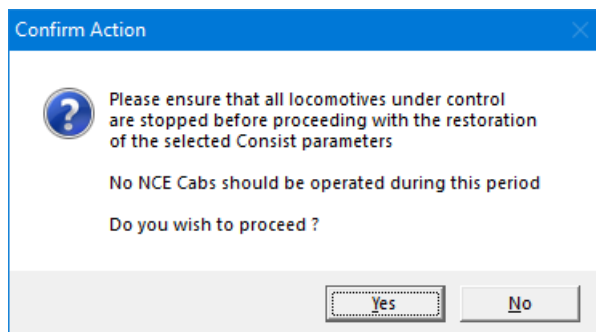

This is important because resetting any of the system parameters, particularly those defining Consists or Handheld Cab allocations could result in you losing control of some

of the Locomotives currently on your layout tracks. When you are sure that all units are stopped, click **Yes** to proceed with selecting and restoring the desired backup data.

Transfer times for restoring data to a Power Pro System are similar to those involved in copying the relevant parameters to backup files, requiring about 5 seconds for System data, 40 seconds for Consists, 35 seconds for a set of 64 Macros, and 15 seconds for a set of eight Handheld Cabs. These times are approximate and will depend to some extent on what other processes are running on your PC at the time.

However, the times taken to restore data to Power Cab, Smart Booster, and DCC Twin Systems are substantially longer, since data can only be written back to these Systems one byte at a time instead of 16 bytes at once with a Power Pro System. For all systems, the restore time for System data will generally be less than 10 seconds, less than 20 seconds for Consist data, and around 35 seconds for Macro data. The restore time for Handheld Cab data is around 55 seconds for a Power Cab, around 85 seconds for a Smart Booster, and up to 105 seconds for the DCC Twin, due to the differing Cab configurations in the three systems.

Restoration of complete system data from a saved Combo file takes less time than restoring all of the components separately, partly because only the essential loco allocation data from the Handheld Cabs is saved and restored (instead of the full memory area belonging to each Cab) but will still occupy about 95 seconds for a Power Cab, 100 seconds for a Smart Booster, and up to 140 seconds for a DCC Twin System.

After Consist data is restored to any System you will see, after a slight pause, A-Track reading back the new Consist parameters to ensure that all data held internally is fully consistent. Similarly, after restoring Handheld Cab data, A-Track will, again after a slight pause, perform a full scan of all attached Cabs to refresh Item allocations (equivalent to clicking on the  Toolbar icon or the **Refresh Item Allocation & Status** option on the **View** menu). When a Combo backup file is restored, the process is followed by refreshes of **both** Consist and Item Allocation data.

With regard to restoring Consist data to the Command Station, note that doing so does not necessarily establish the real Consist on the track, particularly if an NCE Handheld Cab has been used to delete the Consist (KILL CONSIST) after the Consist backup file was created. In such a case, you will need to transfer the Consist to A-Track as described in **Section 6.12**, and then Activate the Consist, ensuring that the assigned Locomotives are physically present on the track.

During restoration you will see the normal NCE Data Transfer progress bar, as shown during the corresponding backup operation, followed by a final confirmation message, as in the examples below, where you should click **OK** to complete the transfer –

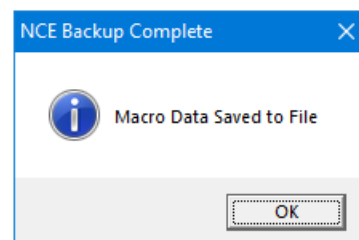
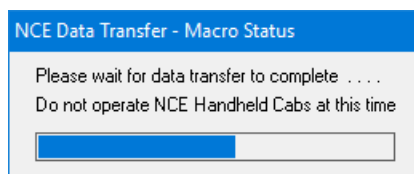

If the data transfer stops because of an error, the error prompt described earlier in this Section will appear. Carefully follow the recovery steps described previously and, when the connection indicators on the status bar, in the bottom righthand corner of the main A-Track window, are all showing **green** again, retry the failed restore operation.

Although Combo backup files for Version 1.65 Power Cab, Smart Booster, or DCC Twin Systems can be restored manually at any time, it can be convenient to perform such a restore automatically whenever A-Track is started, so that the Command Station and attached Handheld Cabs always start in a known state.

To establish an automatic Combo Restore, click the **Combo Data Restore Setup** option on the **File** menu –

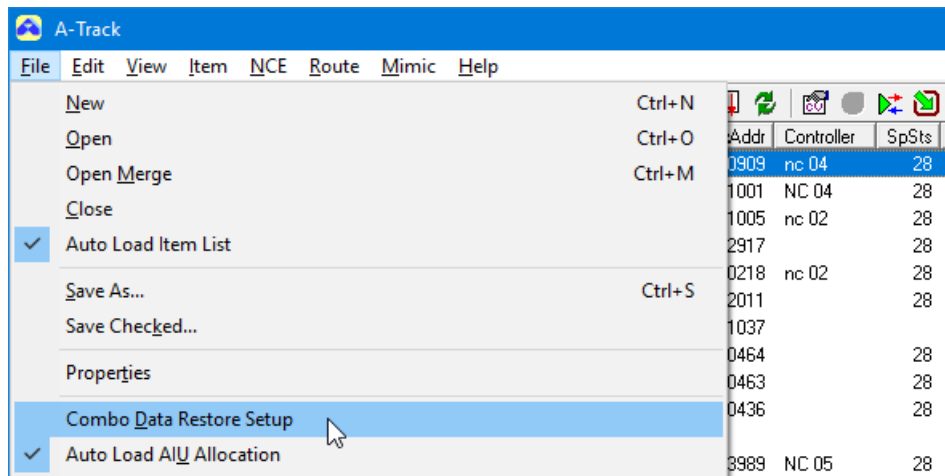

This action opens a setup window with a number of options, and which displays the name of the last Combo file used to restore system data and the folder where it can be found (for a Power Cab in the example below). The title of the setup window will also indicate which type of system which is currently connected to A-Track (a Smart Booster in this case) –

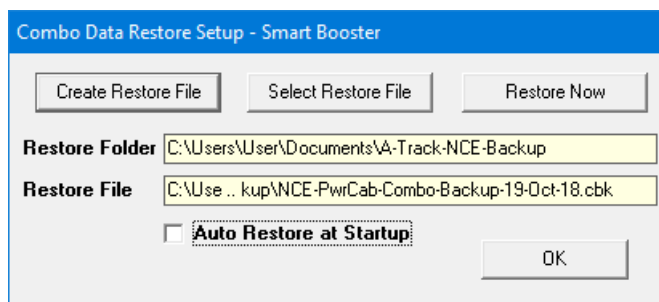

At this point you can either create a new Combo Backup file, by clicking **Create Restore File**, or you can click **Select Restore File** to select an existing Combo Backup file which you created previously.

Creating a new Combo Backup follows exactly the same steps as the backup process described previously, while selecting an existing file is just the same as described for the first part of the general restore process. You will follow the same initial sequences

as though you had clicked on either **SmartBooster Combo Backup** or **SmartBooster Combo Restore** (or equivalent for **PowerCab** or **DCC Twin**) on the **NCE** menu.

In either case, the final result will be that the name of the required Combo Backup file will appear in the **Restore File** textbox, while the name of folder in which it has been saved appears in the **Restore Folder** textbox.

Although you cannot create the wrong type of Combo Backup file, note that, if you select an existing backup file which does not match the currently-attached system, then a warning will be displayed and the file selection process will cease –

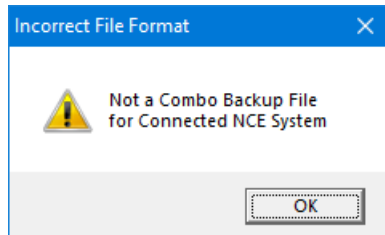

Click **OK** to return to the Setup window where you can then select the correct type of Combo Backup file.

You now have the option of clicking **Restore Now** to perform a complete system data restore, either to return the system to a known state after making some less-than-successful changes or, more commonly, to test that a newly created Combo Backup file will load without any errors.

Clicking **Restore Now** will close the Combo Data Restore Setup window before executing the full restore sequence as described earlier in this Section. Once this has finished, you can open the Setup window again, if required, from the **File** menu.

Alternatively, you can click to tick the **Auto Restore at Startup** checkbox, as shown below, and then click the **OK** button. This has no immediate action other than to save the selected restore parameters then close the Setup window –

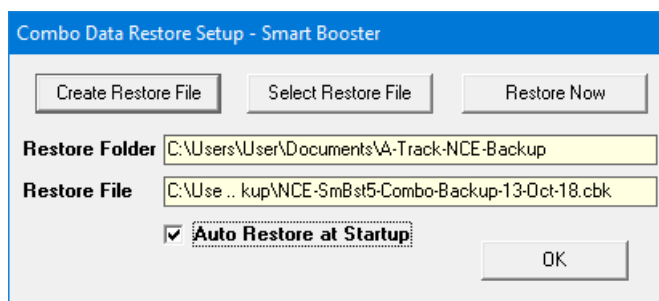

However, the next time A-Track is started, after the initial appearance of the Splash screen and the collection of some basic data from the attached Command Station, a full restore of all System Data from the designated Combo Backup will take place –

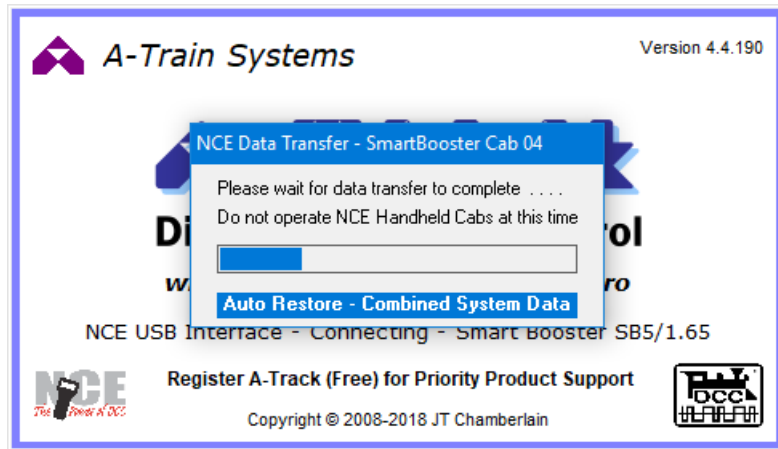

After the full restore operation completes, A-Track will then continue with its normal startup procedure, reading the (restored) Consist status and scanning all attached Cabs to collect Item allocation data.

If, however, you start A-Track with a different Command Station connected, such as using the Power Cab on its own rather than connecting it via a Smart Booster (and remembering to reset the NCE USB Interface jumpers as necessary to suit the new connection) you will see a warning message –

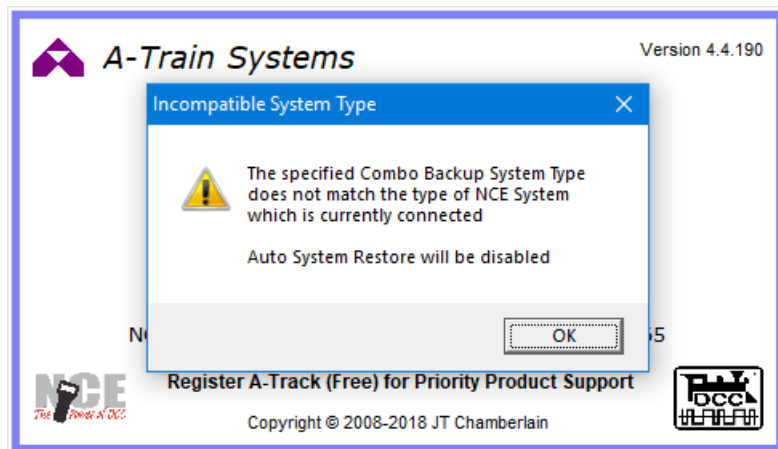

After clicking **OK**, A-Track will proceed with the normal startup sequence without attempting to restore all system settings, and will disable the **Auto Restore at Startup** option, as can be seen if you subsequently open **Combo Data Restore Setup** from the **File** menu –

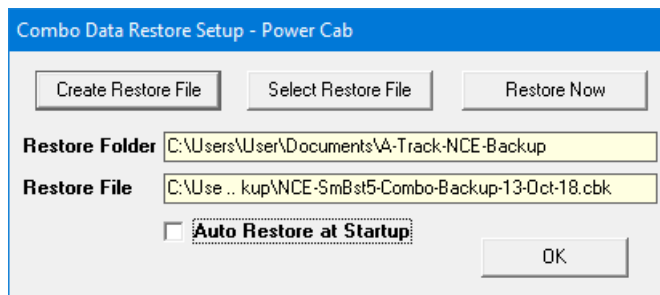

Since the selected Combo Backup file is still for a Smart Booster, clicking either the **Restore Now** button or attempting to tick the **Auto Restore at Startup** checkbox will simply display the error message –

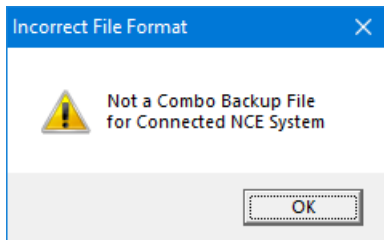

All you can do at this point is to create or select a Combo Restore file for the Power Cab. Re-enabling an automatic system restore for the Smart Booster can only be done when the Smart Booster is reconnected to A-Track.

9.2 Command Station Setup and Status

As well as saving and restoring the NCE Command Station System parameters to, or from, a backup file on your PC, A-Track also allows you to view and amend the complete Command Station parameter setup on the PC screen. Refer to the NCE Power Pro or Power Cab System Reference Manuals for more information on the use and recommended values for each of the available parameters.

Click **Command Station Setup** on the **NCE** menu to see the current values of all System parameters. The example below shows the Command Station settings for an NCE Power Pro as originally delivered from the factory –

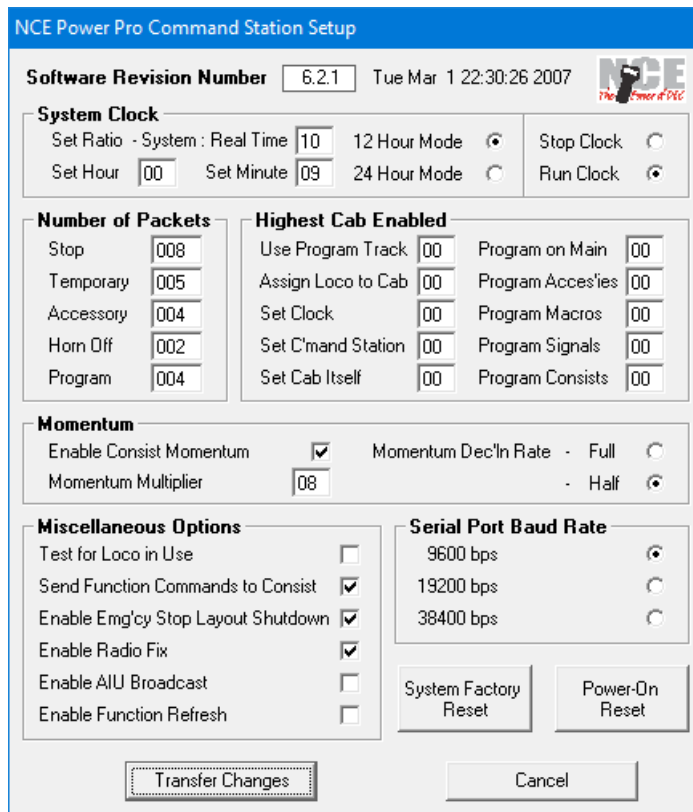

A smaller set of Command Station settings are available for the Version 1.65 Power Cab and Smart Booster, and for the DCC Twin (but not for Version 1.28 systems) –

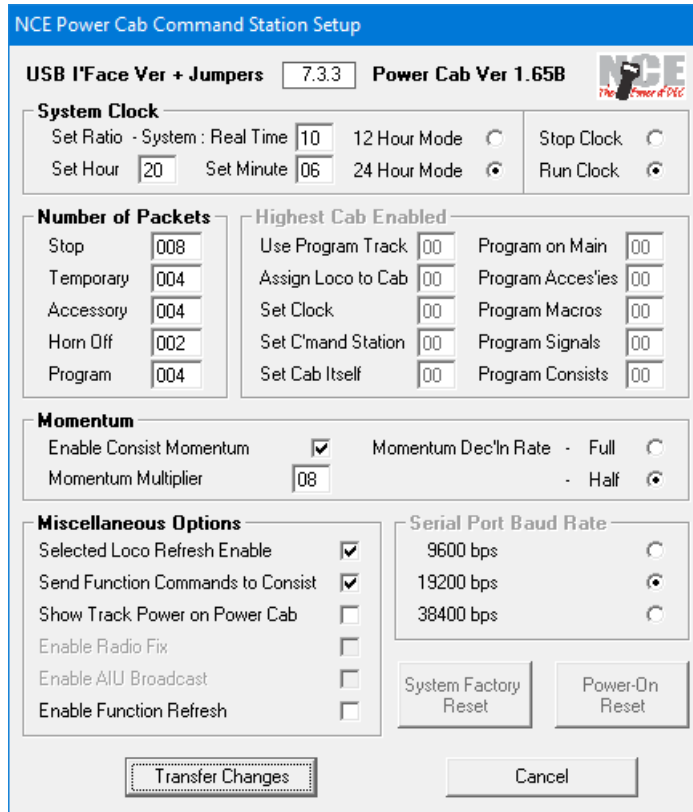

The first row of information for the Power Pro shows the revision number, together with the date and time of release, of the software installed (in EPROM – electrically-programmable read-only memory) within the Command Station. Similar information is displayed for the Power Cab, Smart Booster, or DCC Twin, with the software version number plus the NCE USB Interface version and jumper settings.

Immediately below this are the System (or Fast) Clock settings, showing that the clock is currently running at a Ratio of 10 times faster than real time, and in 12 Hour Mode for the Power Pro. The Power Cab Mode has previously been changed to 24 Hour. Click in any of the textboxes, then type the required value on the keyboard, to change the Clock Ratio, or to set the time you wish to show on any of the NCE Handheld ProCab LCD displays –

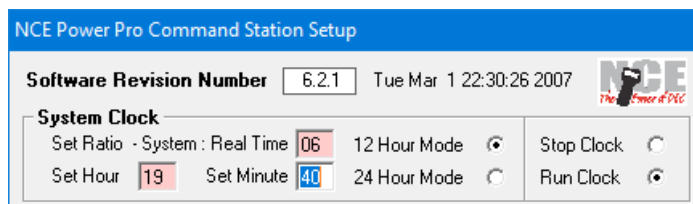

Changed values are highlighted with a **pink** background. When you have completed all of the changes that you wish to make, click the **Transfer Changes** button at the foot of the window to update the Command Station with the new parameter values. If you amend the current time value, remember that the clock will not change to the new

time until the Transfer Changes button is clicked, so you might want to set the value a little in advance of the required time. Although you can choose to display the time in either 12 Hour or 24 Hour mode, you should use the 24 Hour clock to enter values in the Set Hour textbox (as in the example above – enter 19 for 7pm). Confirmation of the transfer is shown by a **light green** highlight applied to all parameter values which have been updated –

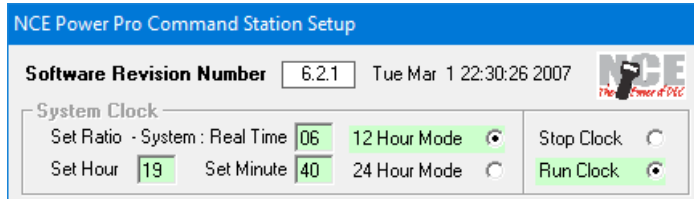

Note that, after you click **Transfer Changes**, you cannot make any further changes to any of the displayed parameters. The only remaining active button is **Close** (which previously showed **Cancel**) at the foot of the window. Click **Close** to remove the Command Station Setup window then, if you do wish to alter any other parameters, re-open the window from the **NCE** menu –

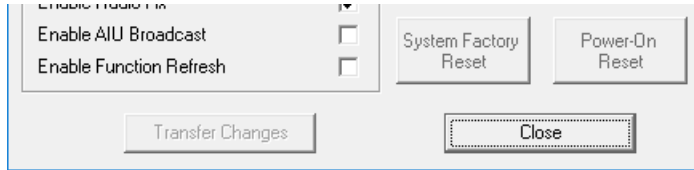

With a few exceptions which are explained later, you can amend as few or as many of the Command Station parameters at one time as you wish, in any of the various categories. Where entry of a numeric value is required, only valid values will be accepted so, as an aid, when you pause with the mouse cursor over any textbox, a small prompt will be displayed to show the range of acceptable values.

An example of the entry of various amendments, and of the display of textbox prompts, is shown below –

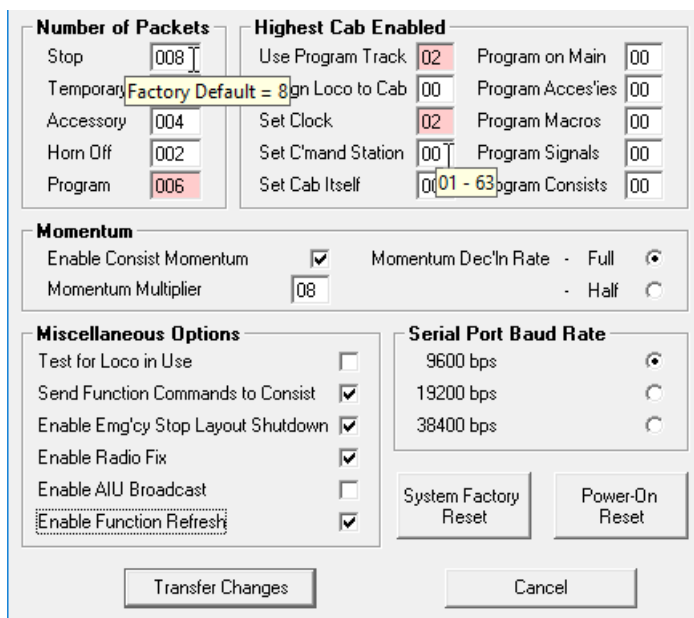

Click **Transfer Changes** to update the Command Station with the amended parameters. As before, confirmation of which parameters have been updated will then be shown by highlighting them with a **light green** background –

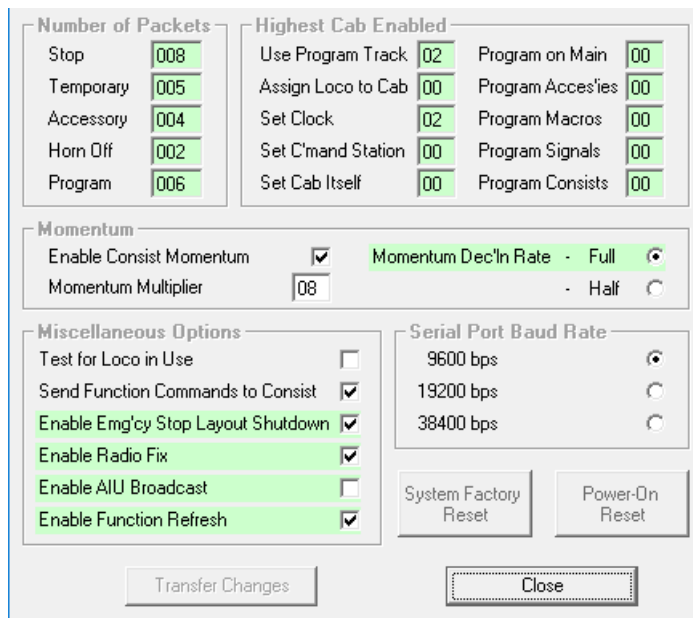

Note that, as indicated by the highlighting, in the case of **Number of Packets**, **Highest Cab Enabled**, and **Miscellaneous Options**, all values in a specific group are updated regardless of how many individual values were changed.

Click **Close** to remove the Command Station Setup window from the screen.

As you may have noted, the **Highest Cab Enabled** set of parameters are not applicable to Power Cab, Smart Booster, and DCC Twin Systems, so are 'greyed-out' in the Command Station Setup window. Nor is it possible to change the **Serial Port Baud Rate** used by the USB Interface for these systems (set at 19200 bps), so these options are also disabled. There are also fewer **Miscellaneous Options** available, compared to the Power Pro, and they differ slightly between the three types of system, as shown –

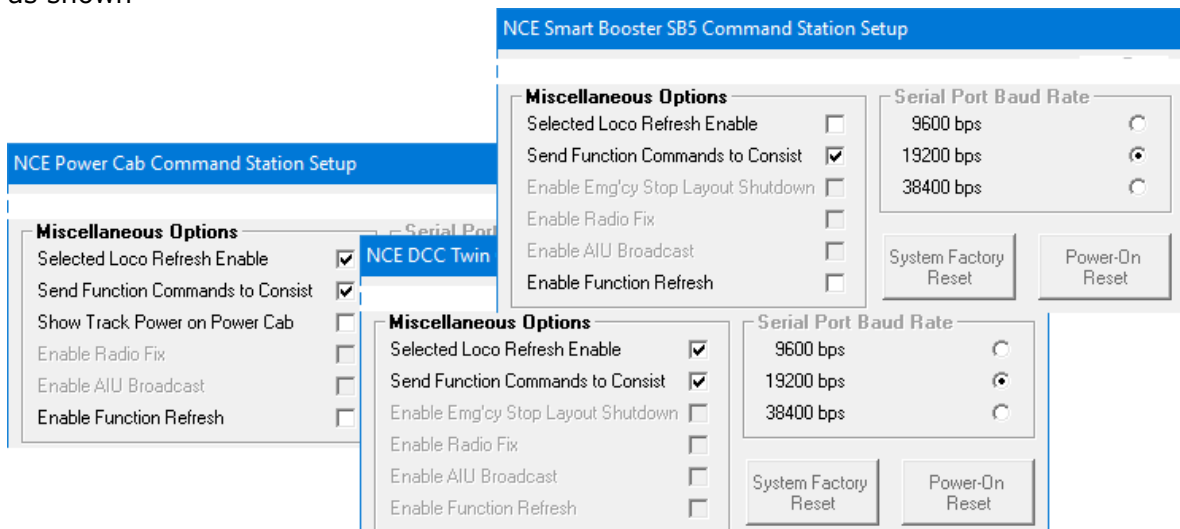

Of the remaining Command Station Setup options, the **Power-On Reset** button allows you to return the Command Station to the state it would be in if you switched it off (removed its power supply), then switched it back on again after a short delay. This option is only available with the Power Pro, so is disabled for the other types of Command Station.

When you click on the **Power-On Reset** button, a warning is displayed –

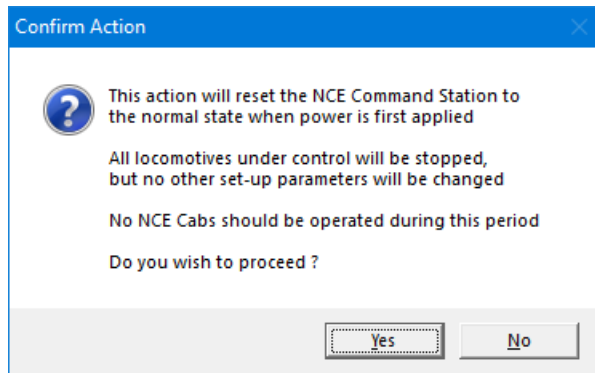

Click **No** to abandon the Power-On Reset operation. Otherwise, if you have locomotives under control on the layout at this time then you may wish to bring them all to a controlled halt *before* clicking **Yes**, since there is a possibility that you will lose control of any moving locomotive. Also, as stated in the warning notice, any amendments you might have made to the Command Station Setup parameters *before* pressing the Power-On Reset button will be disregarded, and will *not* transferred to the Command Station.

Completion of the reset operation is confirmed, as usual, by the Power-On Reset button being shown with a **light green** background –

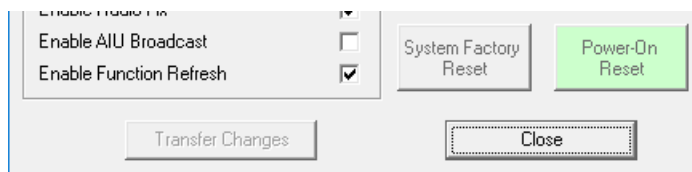

Click **Close** to remove the Command Station Setup window from the screen. Then, if you still wish to change any other parameters, re-open the window from the **NCE** menu.

The second large button, **System Factory Reset**, allows you, as is fairly obvious, to return the Command Station parameters to the state they were in when the unit was originally delivered. Again, this option is only available from A-Track with Power Pro Systems, so is disabled for the other types of Command Station. However, a Factory Reset function is available for Power Cab, Smart Booster, and DCC Twin Systems by accessing the SET CMD STATION options on the Power Cab itself or any attached Handheld ProCab (press the **PROG/ESC** key followed by the **5** key).

Before using the **System Factory Reset** facility, it is worth considering whether you should make backups of some, if not all, of the current settings (System, Consist, Macro, or Handheld Cab) before erasing them completely (see **Section 9.1**).

To avoid accidental loss of Command Station parameters, clicking System Factory Reset does not result in immediate data erasure. Instead, you are first presented with a request to proceed –

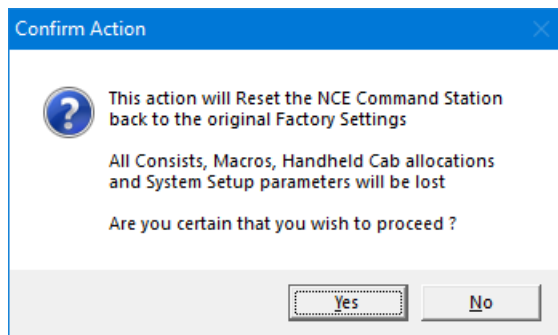

Click **Yes** to continue, or **No** to cancel the System Factory Reset operation. If you choose to proceed, then you must next type in a four-character code exactly as shown in the following window –

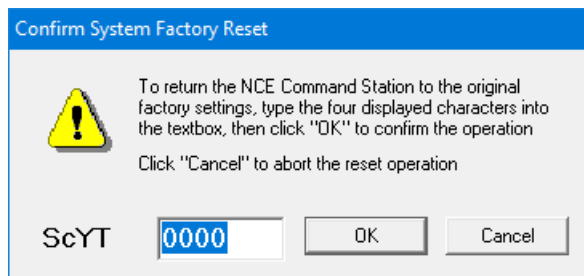

Letters must be entered exactly as shown, using upper- or lower-case where appropriate. To avoid confusion, upper-case letters 'I' and 'O' and lower-case letter 'l' ('L') will not appear, so that they cannot be mistaken for digits '1' or '0' (which can appear in the code).

If you make a typing error then you will see an error message, with another opportunity to type the four-character code correctly. Once the code is entered correctly, click **OK** to reset the Command Station to its Factory Settings – or click **Cancel** to abandon the complete operation –

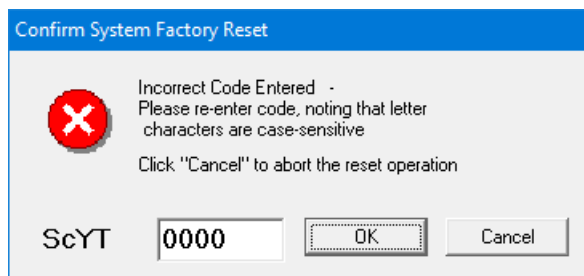

Successful completion of the Command Station System Factory Reset by A-Track will take between 5 and 10 seconds, and will be indicated by the display of a **light green** background to the System Factory Reset button –

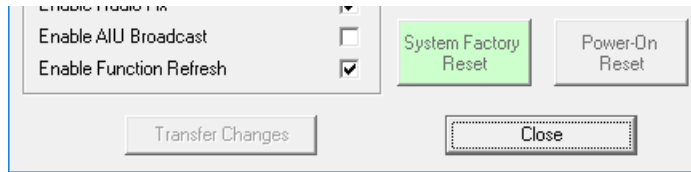

One consequence of performing a System Factory Reset is that the **baud rate** of the NCE Power Pro Command Station serial port will be reset to **9600 bits per second**. This does not cause a problem as far as A-Track is concerned since the speed of the Serial or USB Adapter port will be automatically adjusted to match.

Although the serial port baud rate setting does not directly affect the time taken by A-Track to execute any operations involving the Command Station, such as data backup and restore, using a higher baud rate will improve the efficiency of both the NCE Command Station and A-Track in handling their communications – although it may also render the serial link more liable to encounter errors. The recommendation from NCE is to operate at either 9600 or 19200 bps. However, if you wish, try operation at 38400 bps then, if errors occur too frequently, reduce the baud rate to 19200 bps. Note that, in more recent versions of the NCE Power Pro Command Station, the 38400 bps baud rate may not be fully supported.

You can select a serial port baud rate from the Command Station Setup window simply by clicking on the appropriate option button. The example below shows **19200 bps** being selected –

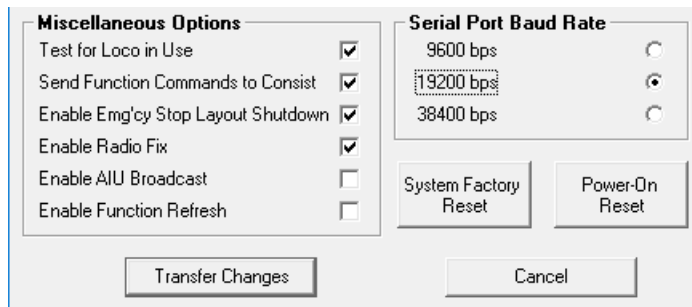

Click **Transfer Changes** as before to update the Command Station. Any other parameter amendments that you have also made will be first be transferred to the Command Station, and then you will see a warning that a Power-On Reset is required in order to update the serial port baud rate (and hence the possibility of losing control of any moving locomotives) –

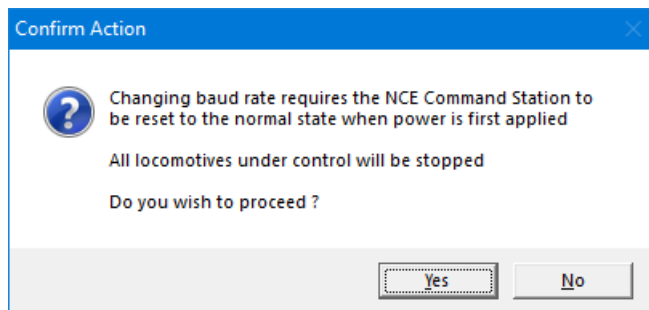

Click **Yes** to change the baud rate, or **No** to leave it as it is. If you do confirm the baud rate change, there will then be a short pause of about 3 seconds before the usual confirmation appears in the form of a **light green** background applied to all parameters which have been updated –

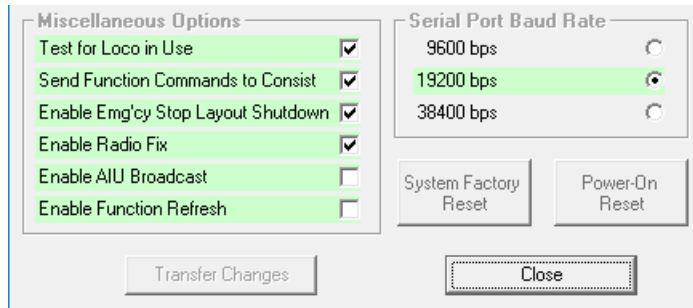

Click **Close** to remove the Command Station Setup window from the screen.

While A-Track gives you additional convenience when setting Command Station parameters, it does not interfere in any way with the facilities provided by NCE, through the ProCab Handheld Controllers, to change any of the Command Station settings directly, as described in the NCE Power Pro or Power Cab System Reference Manuals. Any parameter changes you make using a Handheld Cab will take effect immediately, just as before, and A-Track can then be used, if you wish, simply to review and check the resultant Command Station set-up.

Although changing the majority of parameter values via a Handheld Cab has no effect on A-Track operation, be aware that this is not necessarily the case if you change the **serial port baud rate**.

A-Track is in continuous communication with the NCE Command Station, checking every 2 seconds for changes to the status of the loco currently being controlled by each attached Handheld Cab in turn, and for changes to the inputs to any attached Auxiliary Input Units. In addition, if enabled, A-Track also performs a full update of the status of all attached Handheld Cabs every 6 minutes. If you change the baud rate when A-Track is in the middle of a data transfer then, not only will the data be corrupted, but the likely outcome is that either the Command Station or the Serial or USB Adapter port (or both) will stop communicating, and fail to respond to any further A-Track messages.

A-Track will show this by changing the **leftmost NCE indicator** on the status bar at the foot of the A-Track window from **green** to a continuous **yellow**, in which case you will need to re-establish serial communications by switching off the Command Station for 30 seconds, then powering it on again. In very rare cases it may be necessary to unplug the Serial cable or USB Adapter briefly from the PC's port, then reconnect it again, and then (possibly) close down and restart the A-Track program itself. **Do not** otherwise deliberately unplug the Serial cable or USB Adapter while the A-Track program is running.

A-Track will then adjust the serial interface settings automatically to the new Command Station baud rate, and continue with its normal activities.

If you are fortunate enough to change the Command Station baud rate, using a Handheld Cab, when no data transfer is in progress, then you may see the leftmost NCE indicator on the status bar flicker briefly from **green** to **yellow**, and then back to

green again, as A-Track first receives a garbled response, then proceeds to correct the serial interface baud rate, and resume normal operation. However, the best way to change the serial port baud rate using a Handheld Cab, as part of the Command Station setup, is to do this when the A-Track program is **not running**, and thus not communicating with the Command Station.

9.3 Viewing Consist Backup Files

Once you have created and stored one or more Consist backup files, you can review their contents, using A-Track, without requiring an NCE Command Station to be connected and switched on. While you can review the composition of all of the saved Consists in a file, you cannot edit the saved Consist data directly. It is, however, possible to transfer Consists from a backup file to an A-Track Item List and, therefore, have access to all of the normal Consist editing facilities described in **Section 6.11**.

To review the contents of a Consist backup file, click on the **Consist Status – Backup File / Item List** entry on the **View** menu to open a standard File Open dialog –

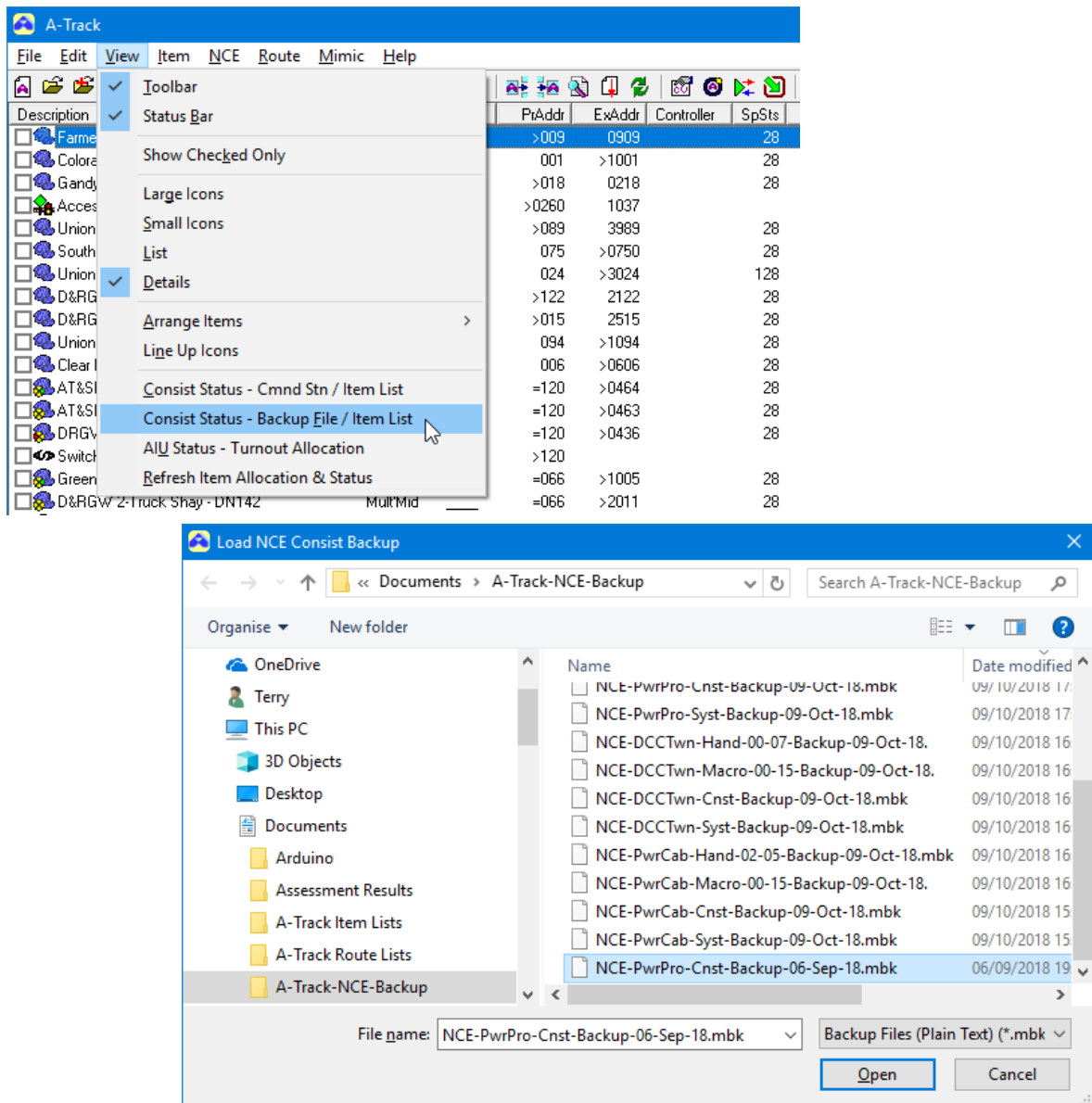

Select the appropriate Consist Backup file to review. If you select either the wrong type of file, or the contents of selected file have been corrupted in some way, you will be presented with an error message such as those below –

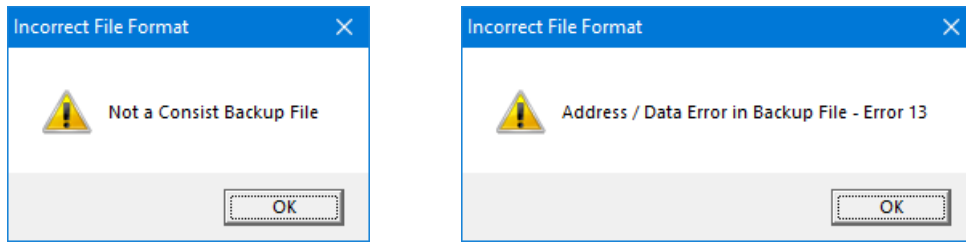

Click **OK** in either case to dismiss the message and let you try again (although if the problem is corrupt data, you need a detailed knowledge of the file structure to attempt a fix – help may be available via Support - see **Section 11.2**).

Otherwise, when the backup file loads, a **Consist Status** window similar to that described in **Section 6.12** will be opened, but with a reduced set of functions –

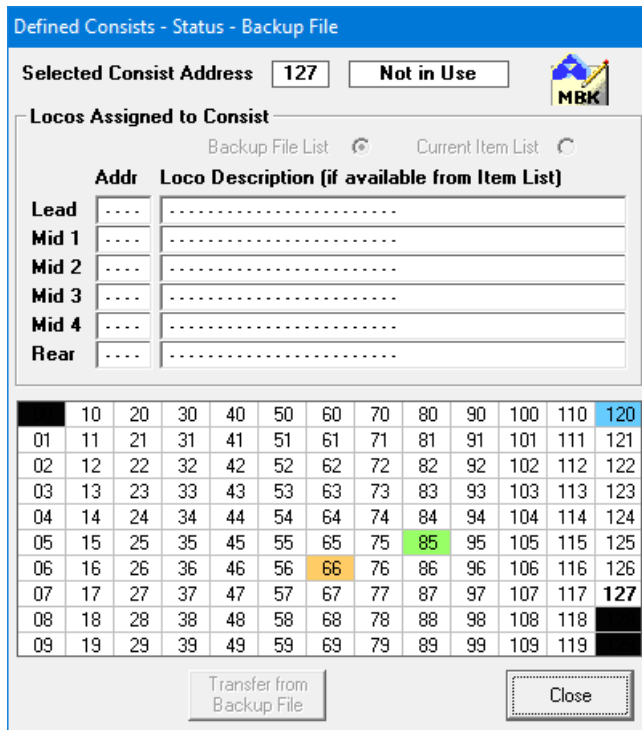

Consists which are defined solely within the currently-loaded A-Track Item List are shown in **blue** (eg. 120) in the Consist Address grid, while those defined only in the loaded Consist Backup File are shown in **green** (eg. 85). Consists with definitions in both Item List and Backup File are shown in **orange** (eg. 66).

Note that the example shown is from a Consist Backup for an NCE Power Pro System. If you are using an NCE Version 1.65 Power Cab or Smart Booster, or a DCC Twin System, then allowable Consist addresses are restricted to a range of 112 to 127, inclusive. While you can still transfer a Consist definition with a lower address into the Item List, it will require its address changed to an allowable value if you subsequently

wish to transfer it to a Ver 1.65 Power Cab or Smart Booster, or DCC Twin, System Command Station.

Clicking on any non-highlighted Consist Address in the grid (such as the default address of 127 shown above) will simply display the message **'Not in Use'** in the textbox at the top of the window.

Clicking on any highlighted Consist Address in the grid will display the addresses of those locomotives assigned to the Consist in the **Addr** column in upper half of the window. If the displayed addresses correspond to Locomotives in the currently-loaded Item List, then those **Loco Descriptions** will also be shown in the textbox to the right of each address, as can be seen below –

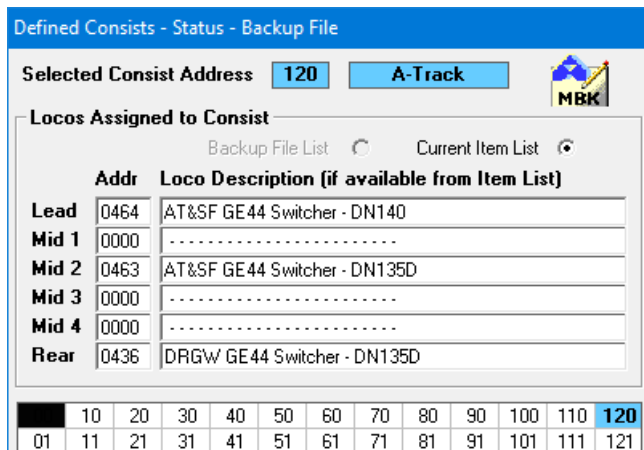

Since the selected Consist, 120, is defined in the loaded Item List, the **Current Item List** option, above the Loco Descriptions, is enabled in this case, as confirmation.

Alternatively, if you click on a highlighted Consist Address identified as only within the backup file, such as 85, the **Backup File List** option will be enabled, and again details of the assigned Locomotives will be displayed, where available –

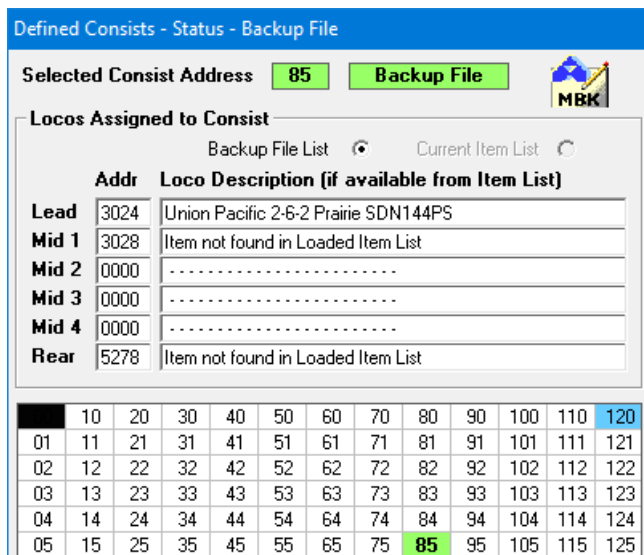

Where the Consist exists in both the Backup File and the Item List, such as Consist 66, you can display the details of either version by clicking on the appropriate option –

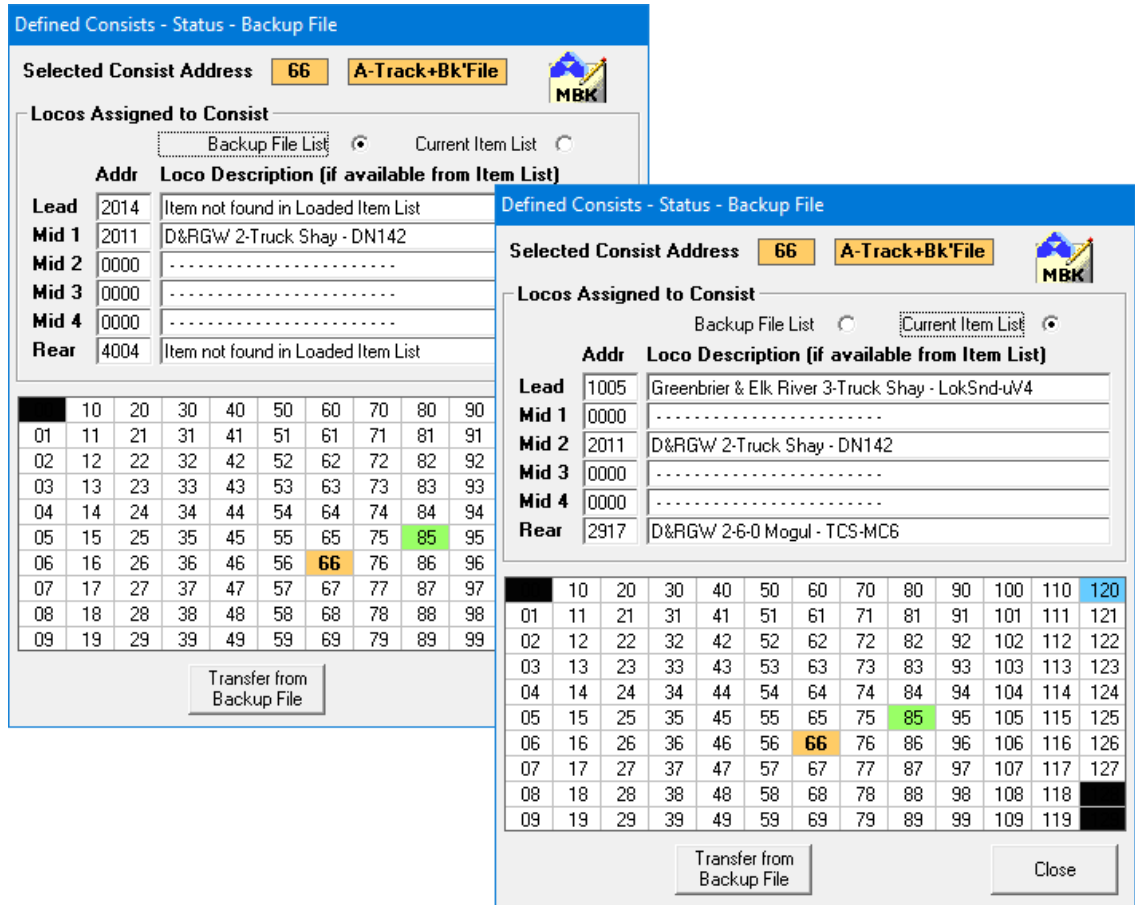

As you can see, apart from the Mid Loco (Address 2011), the Loco Assignments differ between the versions.

Since, in this case, the **Transfer from Backup File** button at the foot of the Consist Status window is enabled, you can, if you wish, transfer the Consist definition from the Backup File to the loaded Item List. If you choose to do this, click **Transfer from Backup File** to add the Consist to the Item List, and then follow the steps described fully in **Section 6.12** in order to add the directions of the assigned Locomotives (which are not stored in the Command Station or backup file), and to handle the renaming and any required update of the newly-created Consists and Multiples.

However, since the Consist in the Backup File has the *same address* as a Consist in the Item List, the transfer will **replace** the assignments to Consist 66 in the Item List with those defined in the Backup File. If you wish to preserve the original version of the Consist in the Item List then you must change its Consist Address to a different value **before** transferring the Backup File version.

Note that it is not possible to Activate a Consist (program the Consist address into the actual assigned Locomotives on the track) directly from a backup file. First, transfer the Consist into the A-Track Item List, then follow the procedures described in **Sections 6.11** and **6.12**.

9.4 Handheld Cab Setup and Status

As described earlier in **Section 3.5**, when A-Track is started the program reads data from the NCE Command Station to determine the current status of all attached Handheld Cabs. The progress of this exercise is shown largely by the state of the middle indicator in the group of three at the righthand end of the Status Bar, at the bottom of the A-Track main window.

The third, middle indicator on the status bar, which is initially **red**, then replaced with an icon indicating the type of connection established, is used to show the progress of A-Track in acquiring the status of all NCE Handheld Cabs connected to the NCE Command Station. After retrieval of the Consist data, the lefthand panel of the status bar will turn **red** and will show which Cab details are being accessed, firstly whether a particular Cab is connected and then loading the data for each active Cab, as shown in the examples below –

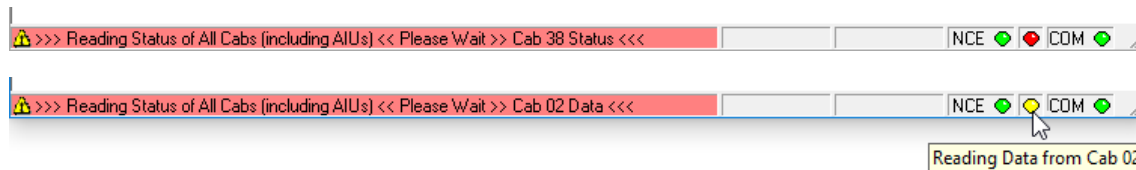

During this process, the middle indicator on the status bar will alternate between **red** and **yellow** while the status of all Cabs is being read, then between **yellow**, and **green** while the full data from all connected Cabs is retrieved. If any Auxiliary Input Units (AIUs) are connected to the NCE Cab Bus, the middle indicator will briefly flash **blue** while the state of their inputs is being loaded. Hovering your mouse cursor over the middle indicator will also display a pop-up label showing the current operation in progress, as can be seen above. After the full scan is completed, the middle indicator will be replaced by an icon representing the type of connected Command Station (such as **PP** or **S**) – see **Section 3.5**)

The time taken to complete this full scan is 2 to 3 seconds per connected Cab if connected to an NCE Power Pro, or about 5 to 7 seconds per Cab when using an NCE Power Cab or Smart Booster Version 1.65 system or a DCC Twin. Including setup time, and because the complete status for Cab Address 02 is always transferred to A-Track, whether or not a Cab with this address is actually connected, the minimum total scan period is about 15 seconds.

Thereafter, A-Track will monitor the status of the Locomotive allocated to each connected NCE Cab, and currently under control (but not those in the Cab Recall List), reading the status of each Cab in turn at 2-second intervals, together with the status of any connected AIUs (and hence the position of all connected layout turnouts). A-Track also checks that the NCE Command Station remains connected (and powered on) every 10 seconds. If you are using a USB-to-Serial converter which is fitted with one or more LED indicators, then you may see the indicators flash to show the transfer of the relevant commands and responses.

However, if the Serial cable or USB Adapter is either unplugged from the PC Serial or USB port, or from the NCE Command Station serial port, or the NCE Command Station is switched off, the middle status indicator will revert to **red** until the connection, or power, is restored to allow the Handheld Cab status scan to recommence.

Whenever a new Item List is loaded, the scan of Handheld Cab addresses will also be restarted, with the middle status indicator initially showing **red** again.

While a Command Station is connected, you can update the displayed Cab allocation and full Cab status at any time by clicking the **Refresh** (🔄) icon on the A-Track toolbar (See **Sections 4.1** and **12.3**) or by clicking on **View** on the A-Track menu bar, followed by **Refresh Item Allocation & Status**. When you use the View menu option, you will be asked whether you wish a periodic scan (every 6 minutes) of attached NCE Cabs to be performed automatically –

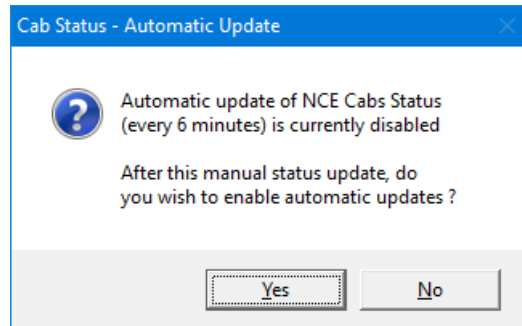

Click **Yes** to enable future automatic scans of NCE Cab status, or **No** to leave further scans disabled (a scan will be performed this time). Leaving scans disabled is preferred if you are actively using A-Track, particularly if are intending to adjust the setup of the NCE Command Station or Cabs, or to change Consist or Macro settings, without being interrupted periodically (all editing is disabled during a Cab status scan).

A **tick** mark next to the **Refresh Item Allocation & Status** option on the View menu will be displayed to indicate that periodic scans of attached NCE Cabs are enabled. In this state, every 6 minutes, A-Track will automatically re-scan the status of the NCE Cabs attached to the Command Station. The current Cab allocation and status will be cleared from the **Item List** (described in **Section 3.7** and in detail in **Chapter 4**), the lefthand panel of the status bar will turn red and will show the scan details, and the middle indicator on the status bar will sequentially show **red, yellow** and **green**, returning to the appropriate connection icon when the full re-scan has been completed. Your choice of whether to enable or disable periodic scans of attached NCE Cabs is saved by A-Track and will be applied each time the program is started.

Further details of the Handheld Cab status scan, and the current state of any Cab's accessible parameters, can be reviewed on the PC screen at any time that the **NCE** menu is available, and amended if required, by clicking **Handheld Cab/AIU Status** on the **NCE** menu.

This will open the **Cab/AIU Status & Setup** window which, after re-scanning the last selected Cab, displays the last recorded status of all Handheld Cabs, and specific details of the last selected Cab which, in the example shown overleaf, are those of the Cab with address 02 attached to a Power Pro System. The overall state of the Cab status scan is shown in the bottom section of the window where, in the **Cab Connected Status** grid, the background colour of each cell shows the connection status of each Cab, from Cab 01 to Cab 63, as follows –

- Cab Address not yet scanned – **white**
(also if Cab Address not supported by the connected Command Station)
- Cab Address scanned – Cab not detected – **pink**
- Cab Address scanned – Cab detected – **light green**
- Cab Address scanned – Auxiliary Input Unit detected – **light blue**
- Cab Address scanned – USB Interface detected – **yellow**

NCE Handheld Cab/AIU Status & Setup

Selected Cab - Address - Type

Cab Parameters

Number of Recalls Analog Horn Channel

Assign Bell to Function Analog Aux Channel

Assign Horn to Function Analog Bias

Allocated Items

Item Description	Addr	Spd	Functions
Greenbrier & Elk River 3-Truck Shay - LokSnd-uW4	1005	F 000	
Item not found in Loaded Item List	0167	F 000	
D&RGW 2-Truck Shay - DN142	2011	F 000	
D&RGW 2-6-0 Mogul - TCS-MC6	2917	F 000	
Item not found in Loaded Item List	0000	R 000	
Item not found in Loaded Item List	0000	R 000	

Cab Connected Status

00	01	02	03	04	05	06	07
08	09	10	11	12	13	14	15
16	17	18	19	20	21	22	23
24	25	26	27	28	29	30	31
32	33	34	35	36	37	38	39
40	41	42	43	44	45	46	47
48	49	50	51	52	53	54	55
56	57	58	59	60	61	62	63

- Cab Detected
- Cab Active
- Cab Allocated
- Cab Data Loaded

The **Cab/AIU Status & Setup** window for a Version 1.65 Power Cab System is similar, as shown below where Cab 04 is selected. Here, the range of addresses is limited to Cab 01 to Cab 10, with Auxiliary Input Units (AIUs) occupying Cab addresses 08 and 09, and an NCE USB Interface in the Cab 10 position -

NCE Handheld Cab/AIU Status & Setup

Selected Cab - Address - Type

Cab Parameters

Number of Recalls Analog Horn Channel

Assign Bell to Function Analog Aux Channel

Assign Horn to Function Analog Bias

Allocated Items

Item Description	Addr	Spd	Functions
Colorado Mining 0-6-0 SaddleTank - Econami	1001	F 011	L_4
Farmers Union Coop EMD40 - NCE-Z14SR	0009	F 000	
Item not found in Loaded Item List	0000	F 000	
Item not found in Loaded Item List	0000	F 000	
Item not found in Loaded Item List	0000	F 000	
Union Pacific EMD Nw2 BL-Paragon2	1094	F 000	

Cab Connected Status

00	01	02	03	04	05	06	07
08	09	10	11	12	13	14	15
16	17	18	19	20	21	22	23
24	25	26	27	28	29	30	31
32	33	34	35	36	37	38	39
40	41	42	43	44	45	46	47
48	49	50	51	52	53	54	55
56	57	58	59	60	61	62	63

- Cab Detected
- Cab Active
- Cab Allocated
- Cab Data Loaded

If a particular Cab is **selected** to display its parameters and allocated Items, by clicking in the grid cell corresponding to its Address, then the cell background colour will change to **dark green** where the Cab has been detected (connected to the Command Station at some time since it was switched on), or to **dark red** if that Cab has not been detected.

The first time you click on a Cab Address grid cell, the corresponding Cab will be scanned (with the display of the normal NCE Data Transfer progress bar), to ensure that the displayed Cab status, allocations, and parameters are up-to-date. Thereafter, any click on that Cab Address cell will simply display the previously-acquired data. Subsequently, if you wish to check on the current status of the Cab, perhaps to verify a change made to one or more of the Cab parameters, click the **Refresh Selected Cab** button when the Cab is selected.

The four Cab status summary flags located to the right of the Cab Connected Status grid indicate the principal attributes of the selected Cab as follows –

- **Cab Detected** – Cab is, or has been, connected to the Command Station
- **Cab Active** – Cab is currently issuing DCC commands to allocated Item(s)
- **Cab Allocated** – Cab has one or more allocated Items in its Recall List
- **Cab Data Loaded** – Cab parameters and allocations have been fully transferred to A-Track

Although the recommendation is that Handheld Cabs should not be operated while accessing their status, simply displaying the operational state of any allocated locomotives will not generally cause any problems.

If any allocated locomotive is under active control then the direction, speed, and state of the headlight plus functions 1 through 8 will be displayed in the **Spd** and **Functions** columns in the list of **Allocated Items**. The number of allocated Items (Locos) in this area depends on the size of Recall List which has been set for this Handheld Cab. Where an allocated Loco Address (shown in the **Addr** column) is found in the loaded Item List, its Description will be displayed in the **Item Description** column.

In the examples shown above, Cab 02 connected to the Power Pro system has no active Items (all zero speed and inactive functions), as shown by the **✘ Cab Active** indicator. Conversely, Cab 04 connected to the Power Cab System is currently controlling Loco 1001 (Forward at Speed Step 11, Function 4 On) and, hence has a **✔ Cab Active** indicator.

The upper part of the Cab/AIU Status & Setup window shows the type of Handheld Cab which is currently selected, together with those parameters which can be changed. In both of the examples shown, the Cab Type is **ProCab**. If, in the second example for a Power Cab System, Cab 02 had been selected, the Cab Type would, of course, be **PowerCab** –



The other type of Handheld Cab which can be recognised is one without an LCD display, such as Cab 06 in the Power Pro System example, the type of which is identified as an NCE **Cab 04/06**, as shown below –

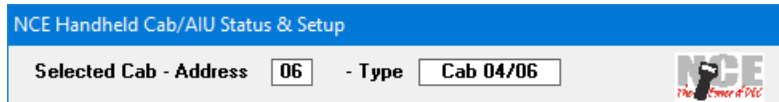

However, if the selected Cab is one which has not currently been detected during the status scan, its type will be shown as **Undefined**, as in the example below –

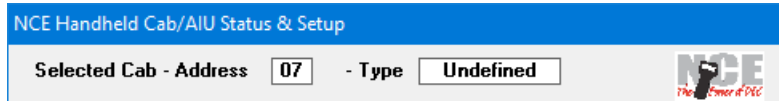

If you are using a DCC Twin System then the two internal Cabs (A and B) can be accessed as Cabs 00 and 01, and will be shown as –

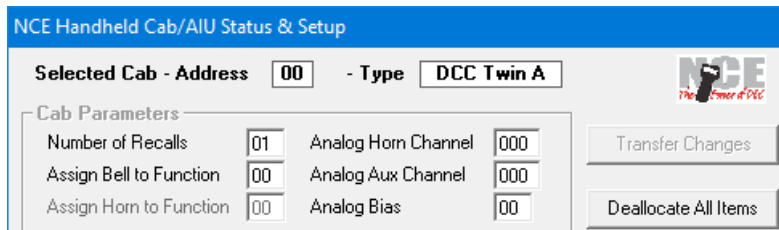

Note that the DCC Twin Cabs do not have any parameters which can be changed, although you can allocate any locomotive to these Cabs to replace the default allocations of Loco 0003 and Loco 0004. Hence, the **Cab Parameters** area and the **Transfer Changes** button are both disabled ('greyed-out').

Once the Cab data has been loaded, either by a click on the Cab Address in the **Cab Connected Status** grid or by clicking **Refresh Selected Cab**, the accessible **Cab Parameters** can be changed by clicking in the appropriate textbox and then typing a new value for the parameter. Only valid values will be accepted, and a note of the allowed range for each parameter will be displayed when the mouse cursor is moved over any textbox, as shown in the example below for Cab 04 –

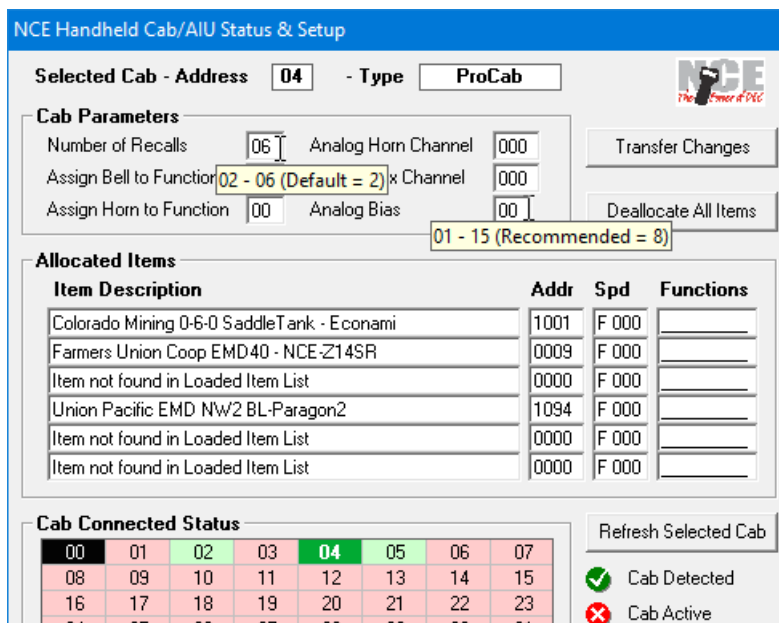

The available parameters are the same for all systems, except for **Assign Horn to Function** which is only available with an NCE Power Pro System (otherwise 'greyed-out'). As shown above, the Cab is not actively controlling any of the three allocated locomotives (**✘ Cab Active**), so we can safely change any of the Cab's parameters, such as the **Number of Recalls**, by clicking in the relevant textbox in the **Cab Parameters** section. Type the required new value then press the Tab (**↹**) key or click in any other textbox. Changed values for **Number of Recalls** and **Assign Bell to Function** are highlighted in **pink** –

If you enter an invalid value for **Number of Recalls** or any other parameter then a warning message, such as that shown below, will be displayed immediately –

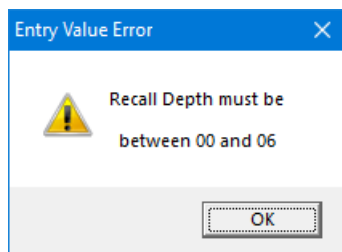

Click **OK**, then enter a valid parameter value.

Click the **Transfer Changes** button to write the new values to the NCE Command Station memory –

After the transfer, the background to the changed values is set to **light green** as confirmation. Note that, because the **Assign Bell** and **Assign Horn to Function** values are held in the same location in the Command Station memory, both values will be updated when either is altered. Although the **Number of Recalls** value has been changed, this will not be immediately reflected in the Cab Status & Setup window, and in the list of **Allocated Items**, until you click the **Refresh Selected Cab** button, when all of the data relevant to the selected Cab will be transferred from the NCE Command Station. The normal Data Transfer progress bar will appear and the Cab/AIU Status & Setup window will be updated with the revised settings. The two slots now unused in the list of **Allocated Items** are shown as empty, with all columns blank –

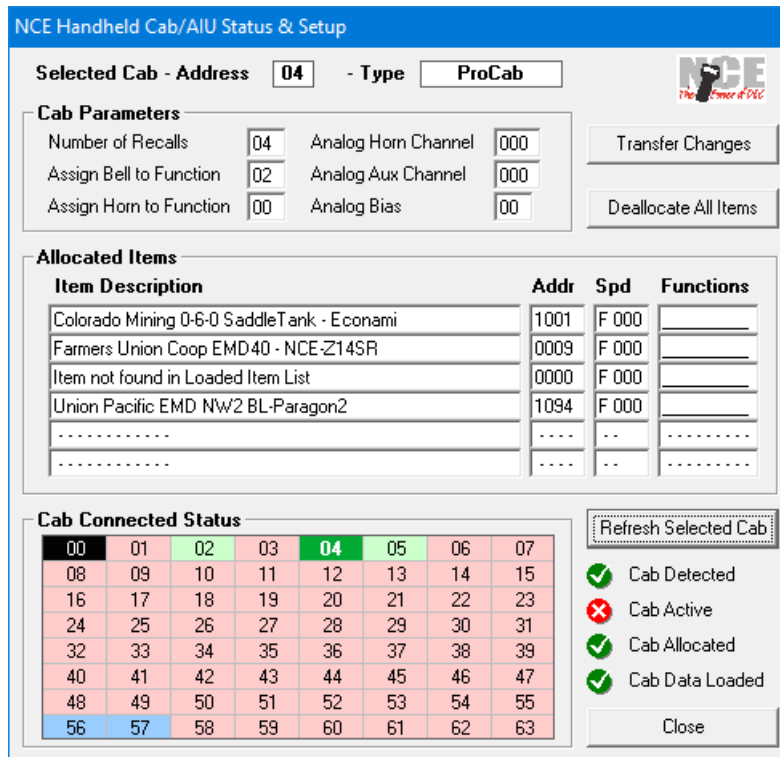

The Cab Parameters shown are the only ones which are stored in the NCE Command Station, and which are, therefore, accessible by A-Track. Other Cab Setup Parameters such as Yard Mode, Speed Button Repeat Rate, or the **OPTION** key value, are stored locally within each Handheld Cab and are not available to A-Track. These local setup parameters can only be changed using the particular Cab itself, by holding down the **SELECT LOCO** button while plugging the Cab into the Command Station, and then following the instructions given in the NCE Power Pro or Power Cab System Reference Manuals.

Note that, although details of the current Allocated Items for the selected Cab are shown, no individual allocation can be changed from the Handheld Cab/AIU Status & Setup window. Any detailed changes to Cab allocations must be made from the Item List as fully described in **Section 6.8**. It is, however, possible to remove all allocations from the selected Cab by clicking the **Deallocate All Items** button. This is much quicker than deallocating each Item individually from the Cab via the Item List.

Since the Deallocate All Items action could, potentially, cause a loss of control over locomotives on your layout, a warning is displayed –

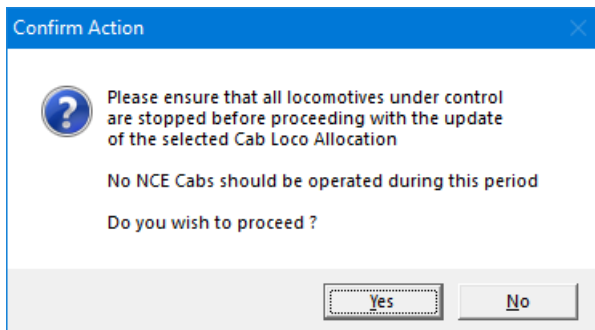

Click **No** to cancel the deallocation operation, or **Yes** to proceed – in which case the background colour of all of the Allocated Items textboxes will change to **pink**, and the normal Data Transfer progress bar will be displayed.

A confirmation window will appear once the Cab update is complete. Click **OK** to continue –

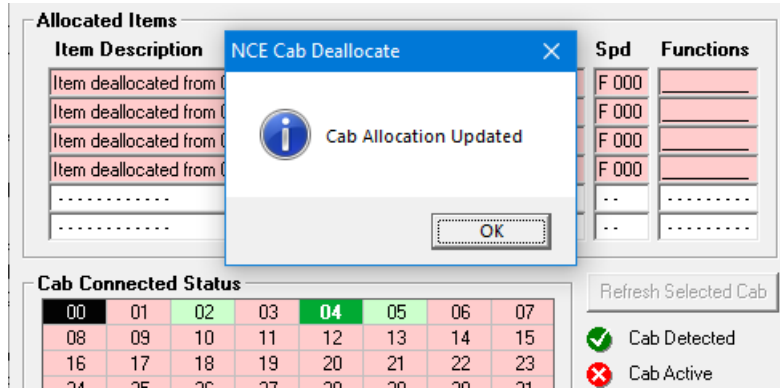

- which will result in the background of all the Allocated Items textboxes changing to **light green**. Note that the **Number of Recalls** remains set at the revised value of 04, so that you will only be able to allocate a maximum of four locomotives to this Cab until you choose to alter Number of Recalls again –

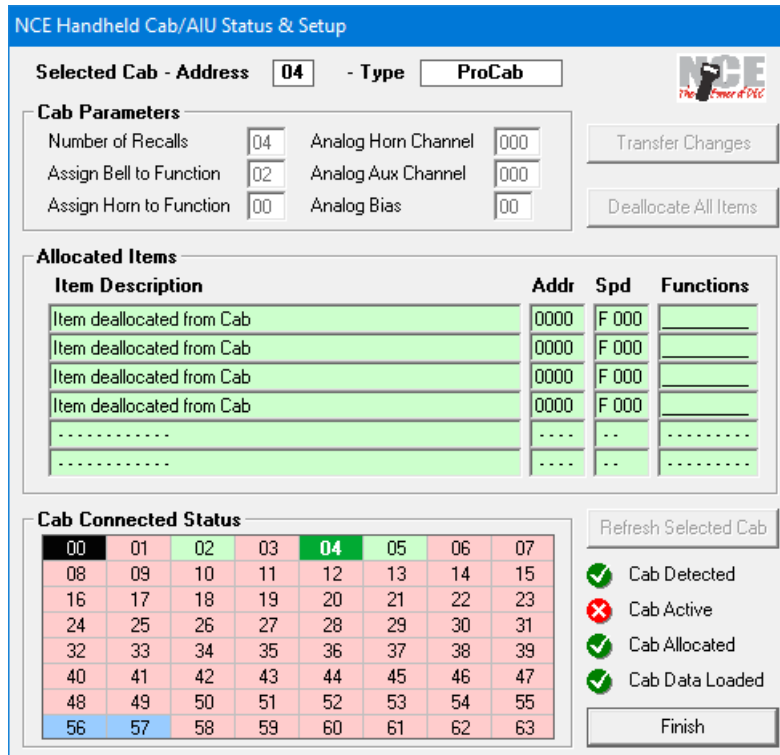

At this point, to ensure everything is updated consistently, it is not possible to make any further immediate changes to the selected Cab, so the only action available is to click the **Finish** button, and thus close the Cab/AIU Status & Setup window.

While the program is running, A-Track remembers the last Handheld Cab Address selected so that, the next time it is opened from the NCE menu, that Cab will be selected, and its parameters and allocations displayed in the relevant sections.

As well as allowing you to see the status of all attached Handheld Cabs, the Handheld Cab/AIU Status & Setup window also provides a view of any connected Auxiliary Input Units (AIUs). Click on the address of an AIU in the **Cab Connected Status** grid to display details of the turnouts connected to that AIU and their current directions. The AIU Address is highlighted in **dark blue**, and the turnout directions in **light green** –

NCE Handheld Cab/AIU Status & Setup

Selected Cab - Address **56** - Type **Aux I/P Unit**

Cab Parameters

Number of Recalls: 02 Analog Horn Channel: 000
 Assign Bell to Function: 01 Analog Aux Channel: 000
 Assign Horn to Function: 00 Analog Bias: 00

Auxiliary Inputs

T/Out	Dirn	Description	T/Out	Dirn	Description		
1	0101	N	FinePineFurn - Siding #2	8	0108	R	Siding #1 - East
2	0102	N	Heath Sawmill Siding #3	9	0121	R	FinePineFurn-Siding#2
3	0103	N	Heath Sawmill Siding #4	10	3121	N	FinePineFurn-Siding#3
4	0104	N	Pine Creek Stores	11	0151	R	Silver Pass West
5	0105	N	O'Grady Leather - Thru	12	0152	N	CreekSand&Gravel West
6	0106	R	Maintenance	13	0153	R	PineCreek Crossing West
7	0107	N	CreekSand&Gravel-East	14	0154	N	PineCreek Crossing East

Cab Connected Status

00	01	02	03	04	05	06	07
08	09	10	11	12	13	14	15
16	17	18	19	20	21	22	23
24	25	26	27	28	29	30	31
32	33	34	35	36	37	38	39
40	41	42	43	44	45	46	47
48	49	50	51	52	53	54	55
56	57	58	59	60	61	62	63

Refresh Selected Cab

- ✓ Cab Detected
- ✓ Cab Active
- ✓ Cab Allocated
- ✓ Cab Data Loaded

Close

AIUs have no editable parameters so the **Cab Parameters** area and **Transfer Changes** button are both disabled, as is the **Deallocate All Items** button. Any changes to AIU Inputs must be made as described in **Section 8.4**.

When you return to view the state of this AIU after selecting some other Cab Address, the turnout directions will no longer be highlighted in **light green** to show that they may not be up-to-date. Click **Refresh Selected Cab** to retrieve their latest status.

Finally, when you have an NCE USB Interface connecting A-Track to your Version 1.65 Power Cab or Smart Booster, or DCC Twin, System, it will appear at Cab Address 10 in the **Cab Connected Status** grid, with its entry highlighted in **yellow**, and the Cab type identified as **USB Interface** –

NCE Handheld Cab/AIU Status & Setup

Selected Cab - Address **10** - Type **USB Interface**

The NCE USB Interface has no editable parameters, so all options in the remainder of the Cab/AIU Status & Setup window are disabled.

9.5 Using Handheld Cabs without an LCD Display

Although perhaps not widely appreciated, the setup parameters and facilities of the NCE Cab-04, Cab-05, and Cab-06 Intermediate Handheld Controllers, which are not fitted with an LCD display panel, are identical to those of the NCE ProCab range – certainly as far as the Command Station and A-Track are both concerned.

This means that the Cab-04, Cab-05, and Cab-06 Handhelds could, in theory, hold up to six Locomotives or Consists in their Recall lists, by setting the Number of Recalls to 06 using the A-Track NCE Handheld Cab/AIU Status & Setup window, and by programming the **OPTION** button on the Handheld Cab itself to have a key value of **66**, so turning it into the equivalent of the ProCab's **RECALL** button.

Setting the Cab-04, Cab-05, or Cab-06 **OPTION** button to operate any of a range of alternative functions is explained fully in the appropriate NCE Cab Operations Manual. Programming it to act as a **RECALL** button is performed as follows –

1. Unplug the Cab from the powered-on NCE Command Station
2. Press and hold down the **SELECT LOCO** button while you plug the Cab back into the Command Station. The Cab will enter its setup mode, indicated by flashing of its status LED.
3. Press the **'4'** button to enter the **OPTION** key setup mode
4. Enter **'66'** as the new key value for the **OPTION** button (press the **'6'** button twice), then press the **ENTER** button
5. Press **SELECT LOCO** to complete the operation

While it would be possible, theoretically, to operate a Cab-04, Cab-05, or Cab-06 Handheld with six Locomotives or Consists in its Recall list by using A-Track to provide a visual display of which Item was currently in the top, active Recall slot, this is not really a practical option when operating a real model railroad layout.

The recommendation, therefore, if you wish to use the **RECALL** function with a non-LCD-display Handheld, is that you restrict the Number of Recalls to the default level of 02. The **OPTION** button can then be used to swap between either of two Locomotives or Consists allocated to that Cab without confusion.

10 PRINTING LISTS AND ITEM DETAILS

A-Track provides a range of facilities to print out all or part of the currently-displayed Item List, the details of one or more individual Items selected from that Item List, all or part of a loaded Route List, or an AIU Allocation List, either to paper or to a file which can be transferred to another computer for printing at a later time, or to be sent to someone else by e-mail. Printing of **Mimic Diagrams** is covered in **Section 8.2**.

The Print facility is accessed from the A-Track menu bar, by clicking on **Print** from the **File** menu, or from the toolbar by clicking on the  icon, or simply by pressing the **Ctrl-P** key combination on the keyboard (hold down either **Ctrl** (Control) key, then press the **P** key) whenever the main A-Track window is selected (has the focus).

The **Print Items & Lists** window which then appears allows you to determine what is printed, by selecting an option from the **Content** section. Here, you can choose to print an **Item Summary**, which is essentially same as the Item List as shown on the screen in Details View, or **Item Details** which gives you full details of each Item, or of a selected number of Items. Alternatively, you can print a loaded **Route Macro List**, either in full or just a selected set of Macros, or a loaded **AIU Allocation List**.

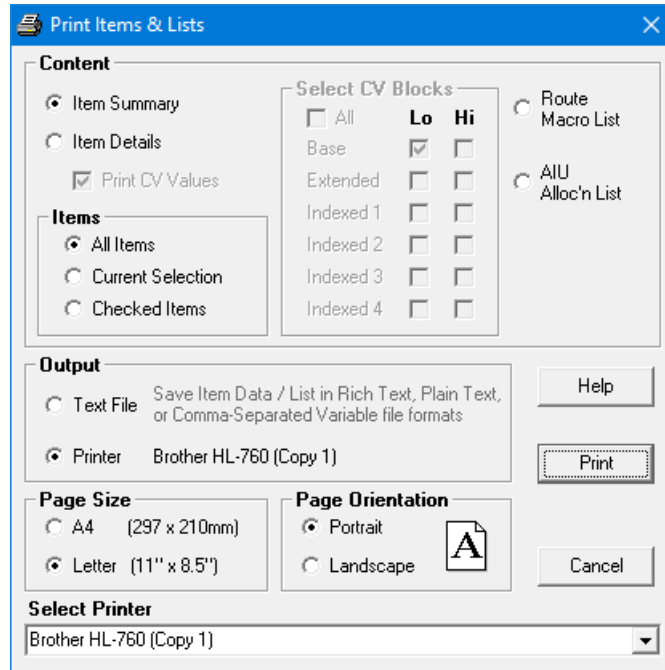

For the chosen **Content** option you can, in most cases, select an **Items** option, to print the relevant information about all Items in the selected List, or to restrict what is printed to only those Items which are currently either selected (highlighted) or checked.

The **Output** section offers you the option of printing directly to an attached printer or to a text file in one of several formats.

A-Track can print the selected information to pages which are formatted for output to either **A4** (297mm x 210mm, 11.69" x 8.27") or **Letter** (11" x 8.5", 279mm x 216mm) size sheets, in either **Portrait** or **Landscape** orientations – by selecting the appropriate options under **Page Size** and **Page Orientation**.

If printing to a Printer, A-Track will automatically select whichever device is currently set as your default printer. However, you can use the **Select Printer** facility at the foot of the window to select any other installed printer to receive the output, by clicking on the small down-arrow (▼) at the righthand end of the listbox to display a list of available printers –

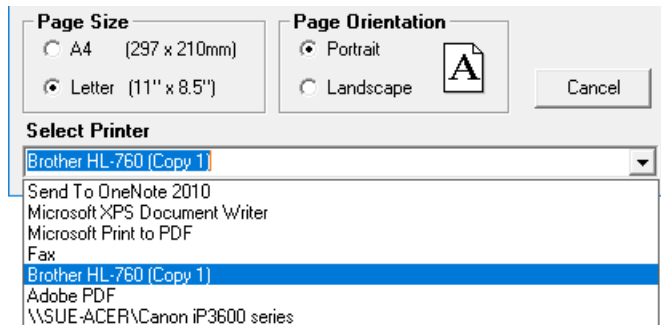

Simply click on the name of the required printer to select it as the output destination.

A-Track remembers whatever print settings you select in the main **Print Items & Lists** window, storing them in the Windows Registry, so that the same set of options will be presented the next time you use the **Print** function. The only exception to this is that the selected printer will always be your PC's default printer (which is not affected by whichever printer you choose from the **Select Printer** list for the current print operation). If you require further information regarding any of the Print options then you can click on **Help** to view the relevant Help Topics (this section of the Reference Manual).

Clicking **Cancel** in the **Print Items** window at any time will abandon any alterations you have made to the Print options and will close the Print Items & Lists window.

10.1 Output Formats

In order to simplify the formatting of the data which is output to either a printer or to a text file, A-Track uses a standard Windows fixed-pitch character font (Courier New) so that all columns are correctly aligned.

The only text formatting which is applied is to highlight some data categories or fields using **bold** or *italic* characters. All text is output as monochrome (black-and-white), and no colour features are incorporated for any purpose. This means that the pages output by the Print facility should print without any problem on any type or configuration of printer.

The printed output has left and top page margins both set equal to 0.75" (19mm).

When printing to a file, you have a choice of printing in either Rich Text Format (RTF) or as plain ANSI text. The simple text formatting employed by A-Track is incorporated in an RTF file so that, when loaded into most word processors, it should produce the same printed page as when printing directly from A-Track to an attached printer. It is also possible to print the various List data fields to a file as Comma-Separated Values (CSV). Such a CSV file can be imported into a spreadsheet, such as Microsoft Excel, which will allow you to display, manipulate, and then export or print the List data fields as a table of values (see **Section 10.4** for further details).

10.2 Direct Printing of an Item Summary

To print an Item Summary from the displayed Item List, open the Print Items & Lists window as described in the introduction to **Chapter 10** above, then select the **Printer** and **Item Summary** options, using **Select Printer**, if necessary, to select the appropriate printer, and then choose the range of Items to be included in the printed output –

- **All Items** – all Items in the Item List will have their displayed details printed – for long Item Lists this also includes Items which are not currently visible, but could be viewed by scrolling the main A-Track window up or down
- **Current Selection** – all Items which are currently highlighted (both on- and off-screen) will have their displayed details printed. Groups of Items are selected (highlighted) by clicking on them in conjunction with use of the **Shift** (↑) and **Ctrl** (Control) keys – in a similar way to the actions described in **Section 4.5** in connection with Item List Copy and Paste operations.
- **Checked Items** – all Items which have their checkbox (located to the left of the Description field) ticked will have their displayed details printed. If you wish to exclude only a small number of Items from the printed list, then check the Items to exclude and then select **Invert Checked** from the **Edit** menu.

Select the **Page Size** of the paper on which you are about to print (A4 or Letter), and then the **Page Orientation**. In Landscape orientation each Item Description will be printed in full (up to 64 characters), whereas, in Portrait orientation, the Description will be truncated, if necessary, to a maximum length of 34 characters. The details for each Item are otherwise the same in either page orientation.

Click **Print** to send a text version of the displayed Item List to the printer. Key features of the print format (Letter-Portrait) are shown below –

Description	Type	Flags	PrAddr	ExtAddr	Control	SpSts
Farmers Union Coop EMD40 - NCE-Z14..	Loco	C	>009	0909	nc04	28
Colorado Mining 0-6-0 SaddleTank -..	Loco	C	001	>1001	nc04	28
Greenbrier & Elk River 3-Truck Sha..	Loco	A P	005	>1005	NC02	28
D&RGW 2-6-0 Mogul - TCS-MC6	Loco	C	017	>2917	nc02	28
Gandy Dancer - DZ120	Loco	F	>018	0218		28
D&RGW 2-Truck Shay - DN142	Loco	C	011	>2011	nc02	28
Accessory Decoder - Wangrow SM-104	Access'y	F	>0260	1037		
AT&SF GE44 Switcher - DN140	Loco	P	064	>0464		28
AT&SF GE44 Switcher - DN135D	Loco	P	063	>0463		28
DRGW GE44 Switcher - DN135D	Loco	P	036	>0436		28
Switcher Consist #2	Consist	P	>120			
Union Pacific Challenger - QSI Tit..	Loco	A P	>089	3989	NC05	28
Southern 4-6-0 Baldwin - SoundTrax..	Loco	P	075	>0750		28

Page 1 Printed : 12 Nov 2018 C:\Users\User\Do..T-Tutorial-Demo-44-181006.it1

As can be seen, details of each constituent Item are printed on a separate row, underneath a **header** row (at the top of each page) showing the title of each column, and a **footer** row (at the bottom of each page) showing the page number, today's date, and the Item List filename and folder (directory) path.

Where the Item List printout occupies several pages, the header and footer are repeated on each page. The number of Item rows printed per page depends on the paper size and orientation which has been selected – A4 paper allows 63 rows in portrait and 39 rows in landscape, while Letter paper allows 59 rows in portrait and 41 rows in landscape.

10.3 Direct Printing of Item Details

The Item Details option lets you print the settings and CV values of any or all Items from the displayed Item List. The option features are best illustrated by printing the full details of a single Locomotive Item so, before opening the **Print Items & Lists** window from **Print** on the **File** menu, or from the  toolbar icon, click on a suitable Item to highlight it.

Next, in the Print Items & Lists window select the **Item Details** and **Printer** options, and click **Select Printer**, if necessary, to select the appropriate printer. Click on **Current Selection** to restrict printing to the selected Item and, for this example, click on the **Print CV Values** checkbox to ensure that it is ticked. Select the required **Page Size**, but note that, for Item Details, the Page Orientation is restricted to Portrait –

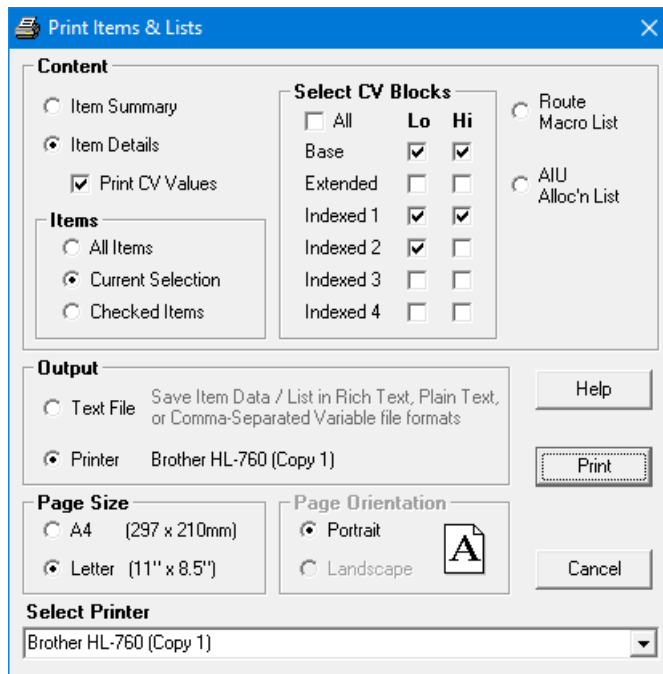

Having ticked the **Print CV Values** checkbox, the **Select CV Blocks** options are enabled, and you have the choice of either clicking the **All** checkbox, to select the contents of all CV Blocks to be printed, or of selecting to print only the contents of specific CV Blocks by ticking the appropriate checkboxes, as shown above.

Note that, even if **All**, or a large selection of individual CV Blocks, is ticked, only those of the selected CV Blocks which are used by the Item will be printed.

Click **Print** to send a text version of the selected Locomotive Item parameters to the printer.

The first page output contains the Item's **Identity** details, plus the selected **Decoder Manufacturer**, followed by all parameters defined by the NMRA DCC Standards, as normally displayed under the **Configuration**, **Speed**, and **Function** Parameter Tabs of the Edit CVs window. These main blocks of information can be seen from the examples which follow, where the top block shows the Item's Description, Type, Addresses, and Configuration, together with the motor control parameters. This is followed by details of the Item's Speed Tables (if any), and a graphical approximation of the Item's speed curve – to the extent that it can be represented by text characters. Finally, there are details of how the Item's Functions are controlled in various configurations, including any Function Remapping – again shown graphically for clarity (no Functions have been remapped in this example).

Subsequent pages list the full descriptions and current values of each of the Item's **Configuration Variables** in the selected CV Blocks. Each page of CV values, on either A4 or Letter paper, contains 54 rows of data, so that each CV Block occupies three printed pages.

Two **header** rows are printed at the top of each page of CV values showing the name of the **CV Block**, and the range of CV addresses which it contains, followed by the titles of the columns showing **CV Number**, **CV Description**, and **CV Value** (shown in decimal and binary). At the bottom of each page is a **footer** row showing the page number, today's date, and the **Item Type** and active **Address**.

These features are shown in the four example printouts on the following pages – the first an Item Details page from an Item with a standard locomotive decoder, followed by a page showing the basic NMRA CVs, then an example CV Block page from an Item with a Quantum sound decoder, and finally an Indexed CV Block page from an Item with a LokSound sound decoder.

The pages showing details of the Item's Configuration Variables are fairly self-explanatory. If you do *not* need details of any of the Item CVs, then ensure that the **Print CV Values** checkbox is not ticked (by clicking on it if necessary) so that only the first Item Details page will be printed for each selected Item.

Alternatively, if you only wish to print out a subset of the CV Values, such as those specific to sound decoder settings, for example, then tick the **Print CV Values** checkbox, and the appropriate **Select CV Blocks** textboxes.

Note that, if **All** CV Blocks are selected, then the full Item Details printout for an Item with a Quantum decoder will occupy 25 pages, whereas that for an Item with a LokSound decoder (an Extended CV Page plus three Indexed CV Pages) will occupy 31 pages.

If the **All Items** option is selected in conjunction with Item Details, then the relevant data pages will be printed for every Item in the Item List. Details of Items will be printed in the order in which the Items are currently displayed on screen, ie. in the order in which they are sorted at present. This is also the case if a group of Items is selected, either by simple highlighting or by ticking their checkboxes.

Pages will be numbered consecutively for the complete printed output, rather than being reset for each individual Item as its details are printed.

```

Item Descr : D&RGW 2-Truck Shay - DN142
Type       : Locomotive           Flags       : Inactive Saved Programmed
Prim'y Addr : 011                 Consist Addr : 000           Extend Addr : >2011
Configur'n : Exten'dAddr SpeedTable NoBiDirCom AltPwrConv 28SpSteps FwdDirn
Auto Stop   : ---                 ---           ---           ---           ---
BiDir Comms : ---                 ---           ---           Decoder MnF : Digitrax Inc
Controller  : nc 02               Speed Steps : 28
Manuf Versn : 250                 User ID #1  : 000
Manufac ID  : 129                 User ID #2  : 000
Alt'n Power : Analog Power        EMF FBk C/O : 000
Pkt TimeOut : 000                 PWM Period  : 131
Acceln Rate : 000                 Deceln Rate : 000
Accl Adjust : 000                 Decl Adjust : 000
SpdTabl/Mid : 000                 F'ward Trim : 000
Kick Start  : 001                 R'vrse Trim : 000

V Start    : 000                 V Mid     : 000                 V High    : 000
Spd Tabl 01 : 016 032 048 064 078 092 106
Spd Tabl 08 : 118 130 142 152 162 172 180
Spd Tabl 15 : 188 196 204 210 216 222 228
Spd Tabl 22 : 232 236 240 244 248 252 255
                240                . . . - ^ ^ 240
                224                . - ^ ^ 224
                208                . - ^ 208
S   192                . - ^ 192
t   176                . - ^ 176
e   160                . - ^ 160
p   144                . - ^ 144
                128                . - ^ 128
V   112                . - ^ 112
a   096                . - ^ 096
l   080                . - ^ 080
u   064                . - ^ 064
e   048                . - ^ 048
                032                . - ^ 032
                016                . - ^ 016
                000                . - ^ 000
SpeedStep > 1 2 3 4 5 6 7 8 9 0:1:2:3:4:5:6:7:8

AltPwr Mode : --- --- -- -- -- --
Func Enabl  : -- -- -- -- -- --
Active Func  : --- --- -- -- -- --
in Consist   : -- -- -- -- -- --
Funct Map > FLF FLR F1 F2 F3 F4 F5 F6 F7 F8 F9 F10 F11 F12
                F12                # F12
F   F11                # F11
u   F10                # F10
n   F9                 # F9
c   F8                 # F8
t   F7                 # F7
                F6                 # F6
S   F5                 # F5
e   F4                 # F4
l   F3                 # F3
e   F2                 # F2
c   F1                 # F1
t   FLR                # FLR
                FLF                # FLF
O/P Active> FLF FLR F1 F2 F3 F4 F5 F6 F7 F8 F9 F10 F11 F12

Page 1                               Printed : 12 Nov 2018                               Loco 2011

```

Item Details – Defined Parameters – Identity, Configuration, Speed, & Functions

CV-Block Base Low (CVs 001 - 128)

CV-No	Description	Dec	Binary
001	Primary Address	011	0000:1011
002	V-Start	000	0000:0000
003	Acceleration Rate	000	0000:0000
004	Deceleration Rate	000	0000:0000
005	V-High	000	0000:0000
006	V-Mid	000	0000:0000
007	Manufacturer Version Number	250	1111:1010
008	Manufacturer ID Number / Reset Factory Defaults	129	1000:0001
009	Total PWM Period	000	0000:0000
010	EMF Feedback Cutout	000	0000:0000
011	Packet Time-Out Value / Sound Time-Out Value	000	0000:0000
012	Power Source Conversion	001	0000:0001
013	Alternate Mode Function Status F1-F8	000	0000:0000
014	Alternate Mode Function Status FL, F9-F12	000	0000:0000
015	Decoder Access Unlock	000	0000:0000
016	Decoder Lock ID Code	000	0000:0000
017	Extended Address MS 6 Bits	199	1100:0111
018	Extended Address LS 8 Bits	219	1101:1011
019	Consist Address	000	0000:0000
020	Reserved by NMRA for future use	000	0000:0000
021	Consist Address Active for F1-F8	000	0000:0000
022	Consist Address Active for FL, F9-F12	000	0000:0000
023	Acceleration Adjustment	000	0000:0000
024	Deceleration Adjustment	000	0000:0000
025	Speed Table / Mid-Range Cab Speed Step	000	0000:0000
026	Reserved by NMRA for future use	000	0000:0000
027	Decoder Automatic Stopping Configuration	000	0000:0000
028	Bi-Directional Communication Configuration	000	0000:0000
029	Configuration Data	054	0011:0110
030	Error Information	000	0000:0000
031	Indexed Page Address High Byte	000	0000:0000
032	Indexed Page Address Low Byte	000	0000:0000
033	Output Control for Function FL(f)	000	0000:0000
034	Output Control for Function FL(r)	000	0000:0000
035	Output Control for Function F1	000	0000:0000
036	Output Control for Function F2	000	0000:0000
037	Output Control for Function F3	000	0000:0000
038	Output Control for Function F4	000	0000:0000
039	Output Control for Function F5	000	0000:0000
040	Output Control for Function F6	000	0000:0000
041	Output Control for Function F7	000	0000:0000
042	Output Control for Function F8	000	0000:0000
043	Output Control for Function F9	000	0000:0000
044	Output Control for Function F10	000	0000:0000
045	Output Control for Function F11	000	0000:0000
046	Output Control for Function F12	000	0000:0000
047	Reserved for Manufacturer use	000	0000:0000
048	Reserved for Manufacturer use	000	0000:0000
049	Forward Light Effect - Headlight	000	0000:0000
050	Reverse Light Effect - Backup Light	000	0000:0000
051	Function 1 Effect	000	0000:0000
052	Function 2 Effect	000	0000:0000
053	Function 3 Effect (FX Only)	000	0000:0000
054	Function 4 Effect (FX Only) /Torque Compensation-Switching ..	000	0000:0000

Item Details – Basic Configuration Variables (CV001 to CV054)

CV-Block Quantum 1 Low (CVs 001 - 128)

CV-No	Quantum	Description	Dec	Binary
055	52.15.0	Cylinder Cocks / Gas Turbine Whine Volume	011	0000:1011
056	52.16.0	Air Pump 1 Volume	011	0000:1011
057	52.17.0	Air Pump 2 Volume (Steam Locos)	011	0000:1011
058		Not Used	000	0000:0000
059	52.19.0	Steam Blower Hiss / Cooling Fans Volume	008	0000:1000
060	52.20.0	Snifter Valve Volume	000	0000:0000
061	52.21.0	Long Air Let-Off Volume	011	0000:1011
062	52.22.0	Short Air Let-Off Volume	011	0000:1011
063		Not Used	000	0000:0000
064	52.24.0	Squealing Brakes Volume	011	0000:1011
065		Not Used	000	0000:0000
066	52.26.0	Steam Dynamo / Diesel Generator Idle Volume	011	0000:1011
067		Not Used	000	0000:0000
068	52.28.0	Dynamic Brakes Fans Volume	000	0000:0000
069	52.29.0	Boiler Pop-Off / Spitter Valve Volume	011	0000:1011
070	52.30.0	Blow Down / Air Dryer Volume	011	0000:1011
071	52.31.0	Injector Volume	011	0000:1011
072	52.32.0	Fuel Sounds Volume (Coal Shovel, Coal Auger)	011	0000:1011
073		Not Used	000	0000:0000
074	52.34.0	Coupler Sounds Volume	011	0000:1011
075		Not Used	000	0000:0000
076		Not Used	000	0000:0000
077	52.37.0	Air Brakes Volume	011	0000:1011
078		Not Used	000	0000:0000
079		Not Used	000	0000:0000
080	52.40.0	Alternate Horn Volume	011	0000:1011
081	52.41.0	Reverser Volume	000	0000:0000
082		Not Used	000	0000:0000
083		Not Used	000	0000:0000
084		Not Used	000	0000:0000
085		Not Used	000	0000:0000
086	52.46.0	User Sound Effect 1 Volume	011	0000:1011
087	52.47.0	User Sound Effect 2 Volume	000	0000:0000
088		Not Used	000	0000:0000
089		Not Used	000	0000:0000
090	52.50.0	Verbal Feedback Volume	000	0000:0000
091		Not Used	000	0000:0000
092	52.52.0	Crew Talk Volume	011	0000:1011
093	52.53.0	Water Loading Scenario Volume	011	0000:1011
094	52.54.0	Water Scoop Volume	011	0000:1011
095	52.55.0	Fuel Loading Scenario Volume	011	0000:1011
096	52.56.0	Maintenance Scenario Volume	011	0000:1011
097	52.57.0	Motor Max RPM Volume	000	0000:0000
098	52.58.0	Motor Exhaust Idle Volume	000	0000:0000
099	52.59.0	Motor Exhaust Max RPM Volume	000	0000:0000
100	52.60.0	Motor Labored Exhaust Min RPM Volume	000	0000:0000
101	52.61.0	Motor Labored Exhaust Max RPM Volume	000	0000:0000
102	52.62.0	Motor Rod Knock Volume	000	0000:0000
103		Not Used	000	0000:0000
104	52.64.0	Generator Max RPM Volume	000	0000:0000
105		Not Used	000	0000:0000
106		Not Used	000	0000:0000
107		Not Used	000	0000:0000
108		Not Used	000	0000:0000

Item Details – Quantum Sound Decoder CVs (CV52.15.0 to CV52.64.0)

CV-Block Indexed 1 Low (CVs 1.257 - 1.384)

CV-No	Description	Dec	Binary
1.257	Not Used	000	0000:0000
1.258	Not Used	000	0000:0000
1.259	Slot 1 Volume - Sound On/Off /Steam Chuff Right Side /Diese..	128	1000:0000
1.260	Not Used	000	0000:0000
1.261	Not Used	000	0000:0000
1.262	Not Used	000	0000:0000
1.263	Not Used	000	0000:0000
1.264	Not Used	000	0000:0000
1.265	Not Used	000	0000:0000
1.266	Not Used	000	0000:0000
1.267	Slot 2 Volume - Sound On/Off / Steam Chuff Left Side	128	1000:0000
1.268	Not Used	000	0000:0000
1.269	Not Used	000	0000:0000
1.270	Not Used	000	0000:0000
1.271	Not Used	000	0000:0000
1.272	Not Used	000	0000:0000
1.273	Not Used	000	0000:0000
1.274	Not Used	000	0000:0000
1.275	Slot 3 Volume - Whistle / Signal Horn #1	064	0100:0000
1.276	Not Used	000	0000:0000
1.277	Not Used	000	0000:0000
1.278	Not Used	000	0000:0000
1.279	Not Used	000	0000:0000
1.280	Not Used	000	0000:0000
1.281	Not Used	000	0000:0000
1.282	Not Used	000	0000:0000
1.283	Slot 4 Volume - Bell / Signal Horn #2	128	1000:0000
1.284	Not Used	000	0000:0000
1.285	Not Used	000	0000:0000
1.286	Not Used	000	0000:0000
1.287	Not Used	000	0000:0000
1.288	Not Used	000	0000:0000
1.289	Not Used	000	0000:0000
1.290	Not Used	000	0000:0000
1.291	Slot 5 Volume - Shovelling /Oil Firebox /Fan Motor (Aux 2) ..	128	1000:0000
1.292	Not Used	000	0000:0000
1.293	Not Used	000	0000:0000
1.294	Not Used	000	0000:0000
1.295	Not Used	000	0000:0000
1.296	Not Used	000	0000:0000
1.297	Not Used	000	0000:0000
1.298	Not Used	000	0000:0000
1.299	Slot 6 Volume - Air Pump /Compressor /Dynamo /Dynamic Brake	128	1000:0000
1.300	Not Used	000	0000:0000
1.301	Not Used	000	0000:0000
1.302	Not Used	000	0000:0000
1.303	Not Used	000	0000:0000
1.304	Not Used	000	0000:0000
1.305	Not Used	000	0000:0000
1.306	Not Used	000	0000:0000
1.307	Slot 7 Volume - Station Announcement #1 /Air Pump /Compressor	128	1000:0000
1.308	Not Used	000	0000:0000
1.309	Not Used	000	0000:0000
1.310	Not Used	000	0000:0000

Item Details – LokSound Sound Decoder CVs (CV1.257 to CV1.310)

10.4 Printing to a Text File

To send your printed output to a file, rather than to paper, select **Text File** in the **Output** section of the Print Items window –

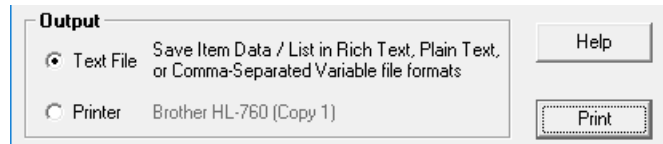

Make the appropriate selections in the **Content** section, exactly as you would do when sending output to a printer, select the required **Page Size** and **Orientation** (if any choice is available), then click **Print**.

In the Windows standard **Print-to-File** dialog window which appears, select the folder where you wish to save the output print file, by using the drop-down listbox at the top of the window, or create a new folder within, say, My Documents in Windows XP, Windows 7, or Windows 8, or Documents in Windows Vista or Windows 10 (see **Section 4.2** for an example of creating a new folder).

Initially, A-Track will open the folder from which you loaded the current Item List but, after you select a more appropriate destination, A-Track will retain the name of the selected Print folder as part of its Registry settings, so that, when you next use the Print-to-File facility, the dialog window will open showing the contents of that folder.

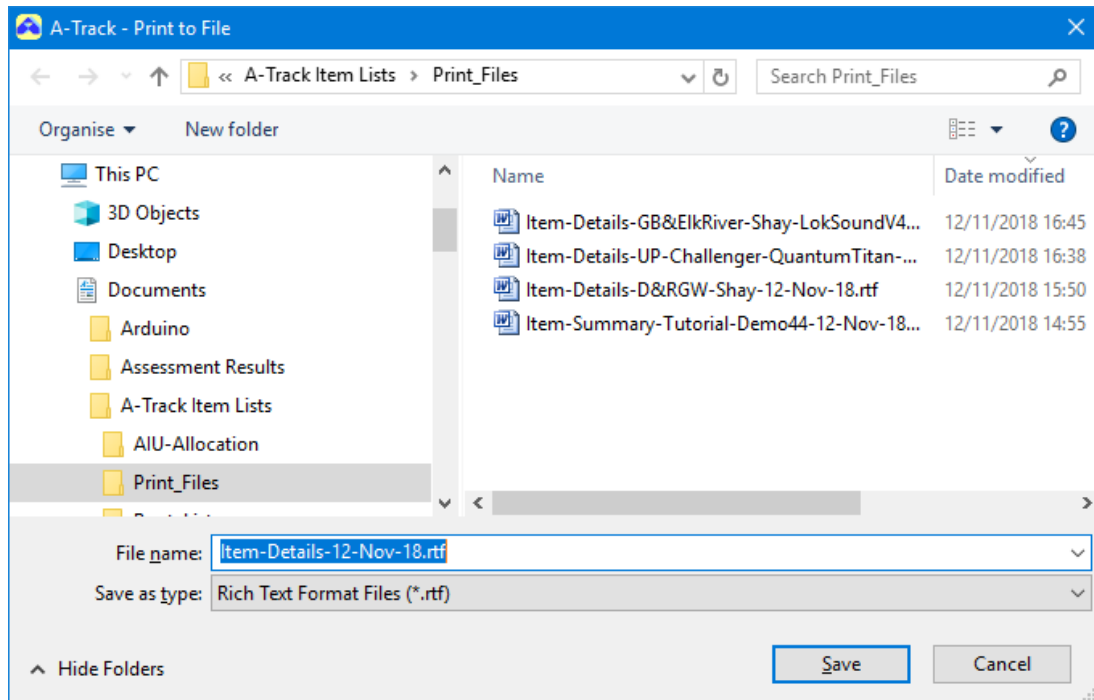

In the **File name:** listbox, A-Track will display a suggested filename of either “Item-Summary-” or “Item-Details-” combined with today’s date, when printing from the Item List. With the selected folder open, you can accept this default filename, amend it by adding some further descriptive details, such as in the examples above, or type your own choice of filename into the **File name:** listbox from the keyboard.

Output print files can be generated in three possible formats –

- **Rich Text Format (.rtf)** – all page, text, and character formatting is included in the file. Hence, when the file is opened in a word-processor application which can handle RTF files, such as those in Microsoft Works or Microsoft Office, the screen view, and the result when printed, will look exactly the same as when the data is sent directly to a printer. Additional text formatting, such as the use of colour, can be inserted at your own discretion.

Note : Older versions of the WordPad basic word-processor (installed as part of Windows in the Accessories folder within Program Files) ignore the page size and margin settings included in the RTF file. Therefore, you will have to set these manually in order to have the pages formatted as intended (via the WordPad File menu and Page Setup). The recommended margin settings, to accommodate small differences in character height and pitch between printers are 0.75" (19mm) for Left and Top Margins, and 0.5" (13mm) for Right and Bottom Margins. Newer versions of WordPad may also require some adjustments to the default line-spacing and paragraph formatting.

- **Comma-Separated Values (.csv)** – this is a specialised file format intended to allow the import of Item parameters and data into tables or spreadsheets. If you save an Item Summary, Item Details, Route List, or Allocation List in this type of file, then it is assumed that you have the necessary expertise to transfer the data into an appropriate application such as Microsoft Excel, and to handle it within the application.
- **Plain Text (.txt)** – this type of file contains only ANSI-encoded text characters, separated by line-break (CR-LF) characters, where required, but without any other character (bold or italic), or page (size and margin), formatting. The contents of the file can be displayed and printed using any text editor (such as Notepad) or a word-processor, but you will have to set page size and margins manually (to the values suggested in the paragraph above). You can, of course, then format the text in whatever manner you wish using a suitable word-processor.

The suggested file format is **Rich Text**, shown by the **.rtf** extension to the initially displayed filename. Click on the drop-down arrow at the righthand end of the **Save as type:** listbox, as shown below, and then select, from the listed options, the type of output file to be generated. The 'All Files (*.*)' option, as shown, allows you to see all files already stored in the selected folder, in whatever format –

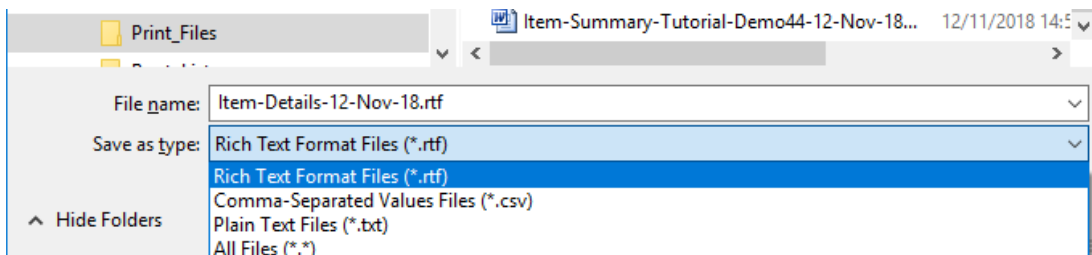

Important : When choosing a filename and file type for the Print file, if you select **All Files (*.*)** from the **Save as type:** listbox, and give the file *any* extension other than **.rtf**, **.csv**, or **.txt**, then, although the file will be saved with your given extension, *it will be saved in Plain Text (*.txt) format*. This may well confuse Windows and most

application programs when you attempt to open or import the file at a later date, and is to be strongly discouraged unless you are very sure of what you are doing.

The format of the **CSV** file produced by the A-Track Print facility for an **Item Summary** is similar to that of the TXT format, in that it contains no page size nor margin settings, but neither does it contain the header or footer rows found in RTF and TXT print files. Instead, a single row containing the full filename of the Item List, plus the date of printing, is inserted above the rows containing summary data for each selected Item.

An example of a CSV-format Item Summary imported into a Microsoft Excel spreadsheet is shown below –

	A	B	C	D	E	F	G
1							
2	C:\Users\User\Documents\A-Track Item Lists\AT-Tutorial-Demo-44-181006.itl	Printed : 12 Nov 2018					
3							
4	Description	Type	Flags	PrAddr	ExtAddr	Control	SpSts
5	Farmers Union Coop EMD40 - NCE-Z14SR	Loco	C	>009	909	nc 04	28
6	Colorado Mining 0-6-0 SaddleTank - Econami	Loco	C	1	>1001	nc 04	28
7	Greenbrier & Elk River 3-Truck Shay - LokSnd-uV4	Loco	A P	5	>1005	NC 02	28
8	D&RGW 2-6-0 Mogul - TCS-MC6	Loco	C	17	>2917	nc 02	28
9	Gandy Dancer - DZ120	Loco	P	>018	218		28
10	D&RGW 2-Truck Shay - DN142	Loco	C	11	>2011	nc 02	28
11	Accessory Decoder - Wangrow SM-104	Access'y	P	>0260	1037		
12	AT&SF GE44 Switcher - DN140	Loco	P	64	>0464		28
13	AT&SF GE44 Switcher - DN135D	Loco	P	63	>0463		28
14	DRGW GE44 Switcher - DN135D	Loco	P	36	>0436		28
15	Switcher Consist #2	Consist	P	>120			
16	Union Pacific Challenger - QSI Titan Steam	Loco	A P	>089	3989	NC 05	28
17	Southern 4-6-0 Baldwin - SoundTraxx Tsunami	Loco	P	75	>0750		28
18	Union Pacific 2-6-2 Prairie SDN144PS	Loco	P	24	>3024		128
19	D&RGW FMH10-44 - Quantum	Loco	P	>122	2122		28
20	D&RGW 2-8-0 Consolidation - LokSnd Select	Loco	P	>015	2515		28
21	Union Pacific EMD NW2 BL-Paragon2	Loco	A P	94	>1094	NC 04	28
22	Clear Lake Lumber 2-Truck Climax - ZimoMX648R	Loco	C	6	>0606	nc 05	28
23	Pine Creek Yard - NCE Switch-8	Access'y	P	26	>0102		
24	Forest Flat - Tam Valley Quad-PIC	Access'y	P	51	>0201		
25	McGilligan Lumber #2 - NCE Switch-It Mk2	Access'y	P	56	>0221		
26	Fine Pine Furn Sidings - NCE Snap-It	Access'y	P	31	>0121		
27	Heath Sawmill Siding #3 - NCE Switch-Kat	Access'y	P	31	>0122		
28	Silver Pass - DCC-Concepts - Cobalt AD4	Access'y	P	36	>0143		
29	Pine Creek West - Lenz LS150	Access'y	P	38	>0151		
30	High Peak - Digitrax DS52	Access'y	P	33	>0131		
31	McGilligan Lumber #1 - NCE Switch-It	Access'y	P	53	>0212		

Note that the width of column A above has been increased to reveal the filename and full Item Descriptions, and columns C to G have been right-justified to improve readability. If you are intending to make this type of data transfer regularly, then you can set up, and save, a blank Excel spreadsheet with all column and text formatting and alignment adjusted to your own liking, then use it as a template into which you can import data from an A-Track CSV Print file (using the Import External Data function from the Excel Data menu).

When printing **Item Details** to a **CSV** Print File, the first page of formatted Item Details is neither generated nor transferred to the file, and the only information which is saved for each selected Item is that relating to the Item's Configuration Variables. Hence, if printing Item Details to a CSV file *without* ticking the **Print CV Values** checkbox, and at least one **Select CV Blocks** checkbox, ie. no CVs selected, then all that will be saved to the file is a pair of header rows for each selected Item.

The group of CV Blocks for each selected Item is preceded by a row containing the full filename of the Item List, plus the date of printing, followed by a further row with the Item Type, active Address, and Description.

Each output row containing details of a selected CV consists of a Block Reference which identifies the CV Block and the position of the CV within it, the CV Number in Indexed form, the CV Description, and finally the value of the CV in both decimal and binary, as shown below in an example of an Item Details CSV file imported into a Microsoft Excel spreadsheet –

The screenshot shows an Excel spreadsheet titled 'Item-Details-D&RGW-Shay-12-Nov-18.csv'. The spreadsheet contains the following data:

	A	B	C	D	E
1					
2			C:\Users\User\Documents\A-Track Item Lists\AT-Tutorial-Demo-44-181006.itl		
3			Printed : 12 Nov 2018		
4					
5	Loco	>2011	D&RGW 2-Truck Shay - DN142		
6					
7	Block-Ref	CV-No	Description	Dec	Binary
8	BSL-001	0-001	Primary Address	11	0000-1011
9	BSL-002	0-002	V-Start	0	0000-0000
10	BSL-003	0-003	Acceleration Rate	0	0000-0000
11	BSL-004	0-004	Deceleration Rate	0	0000-0000
12	BSL-005	0-005	V-High	0	0000-0000
13	BSL-006	0-006	V-Mid	0	0000-0000
14	BSL-007	0-007	Manufacturer Version Number	250	1111-1010
15	BSL-008	0-008	Manufacturer ID Number / Reset Factory Defaults	129	1000-0001
16	BSL-009	0-009	Total PWM Period	0	0000-0000
17	BSL-010	0-010	EMF Feedback Cutout	0	0000-0000
18	BSL-011	0-011	Packet Time-Out Value / Sound Time-Out Value	0	0000-0000
19	BSL-012	0-012	Power Source Conversion	1	0000-0001
20	BSL-013	0-013	Alternate Mode Function Status F1-F8	0	0000-0000
21	BSL-014	0-014	Alternate Mode Function Status FL+ F9-F12	0	0000-0000
22	BSL-015	0-015	Decoder Access Unlock	0	0000-0000
23	BSL-016	0-016	Decoder Lock ID Code	0	0000-0000
24	BSL-017	0-017	Extended Address MS 6 Bits	199	1100-0111
25	BSL-018	0-018	Extended Address LS 8 Bits	219	1101-1011
26	BSL-019	0-019	Consist Address	0	0000-0000
27	BSL-020	0-020	Reserved by NMRA for future use	0	0000-0000
28	BSL-021	0-021	Consist Address Active for F1-F8	0	0000-0000
29	BSL-022	0-022	Consist Address Active for FL+ F9-F12	0	0000-0000
30	BSL-023	0-023	Acceleration Adjustment	0	0000-0000
31	BSL-024	0-024	Deceleration Adjustment	0	0000-0000
32	BSL-025	0-025	Speed Table / Mid-Range Cab Speed Step	0	0000-0000
33	BSL-026	0-026	Reserved by NMRA for future use	0	0000-0000
34	BSL-027	0-027	Decoder Automatic Stopping Configuration	0	0000-0000
35	BSL-028	0-028	Bi-Directional Communication Configuration	0	0000-0000
36	BSL-029	0-029	Configuration Data	54	0011-0110

The width of columns C and E has been increased in this case to let you see the full CV Descriptions and CV Binary values, and columns D and E have been right-aligned, but any additional formatting is left as an exercise for the interested user.

As mentioned above, the CV Number is shown in Indexed form, where a prefix of **0-** is used to identify CVs in both Base and Extended Blocks, with **1-**, **2-**, etc. for Indexed Blocks, as used in LokSound decoders. CV Numbers for Quantum decoders use the standard QSI indexing scheme. Two examples of the numbering scheme are shown below –

Item-Details-GB&ElkRiver-Shay-LokSoundV4-13-Nov-18.csv					
	A	B	C	D	E
936	X2H-026	2-410	Assign Fn - F04 / Select-Fn - F08 Physical / Output Mapping..	4	0000-0100
937	X2H-027	2-411	Output Mapping Physical 10-L	0	0000-0000
938	X2H-028	2-412	Assign Fn - F04 / Select-Fn - F08 Logic #1 / Output Mapping..	0	0000-0000
939	X2H-029	2-413	Assign Fn - F04 / Select-Fn - F08 Logic #2 / Output Mapping..	0	0000-0000
940	X2H-030	2-414	Assign Fn - F04 / Select-Fn - F08 Sound #1 / Output Mapping..	0	0000-0000
941	X2H-031	2-415	Assign Fn - F04 / Select-Fn - F08 Sound #2 / Output Mapping..	32	0010-0000
942	X2H-032	2-416	Assign Fn - F04 Sound #3 / Output Mapping Sound 10-Q	0	0000-0000
943	X2H-033	2-417	Function Key Mapping 11-A	0	0000-0000
944	X2H-034	2-418	Function Key Mapping 11-B	64	0100-0000
945	X2H-035	2-419	Function Key Mapping 11-C	0	0000-0000
946	X2H-036	2-420	Function Key Mapping 11-D	0	0000-0000
947	X2H-037	2-421	Function Key Mapping 11-E	0	0000-0000
948	X2H-038	2-422	Function Key Mapping 11-F	0	0000-0000
949	X2H-039	2-423	Function Key Mapping 11-G	0	0000-0000
950	X2H-040	2-424	Function Key Mapping 11-H	0	0000-0000
951	X2H-041	2-425	Function Key Mapping 11-I	0	0000-0000
952	X2H-042	2-426	Assign Fn - F05 / Select-Fn - F09 Physical / Output Mapping..	0	0000-0000
953	X2H-043	2-427	Output Mapping Physical 11-L	0	0000-0000
954	X2H-044	2-428	Assign Fn - F05 / Select-Fn - F09 Logic #1 / Output Mapping..	0	0000-0000
955	X2H-045	2-429	Assign Fn - F05 / Select-Fn - F09 Logic #2 / Output Mapping..	0	0000-0000
956	X2H-046	2-430	Assign Fn - F05 / Select-Fn - F09 Sound #1 / Output Mapping..	32	0010-0000
957	X2H-047	2-431	Assign Fn - F05 / Select-Fn - F09 Sound #2 / Output Mapping..	0	0000-0000
958	X2H-048	2-432	Assign Fn - F05 Sound #3 / Output Mapping Sound 11-Q	0	0000-0000
959	X2H-049	2-433	Function Key Mapping 12-A	0	0000-0000
960	X2H-050	2-434	Function Key Mapping 12-B	0	0000-0000
961	X2H-051	2-435	Function Key Mapping 12-C	1	0000-0001
962	X2H-052	2-436	Function Key Mapping 12-D	0	0000-0000

Item-Details-UPChallenger-QuantumTitan-13-Nov-18.csv					
	A	B	C	D	E
313	Q1L-048	52.8.0	Bell Volume	11	0000-1011
314	Q1L-049		Not Used	0	0000-0000
315	Q1L-050	52.10.0	Chuff /Prime Mover1 /Diesel Motor Idle /Traction Motor Volume	11	0000-1011
316	Q1L-051	52.11.0	Chuff 2 /Prime Mover2 /Diesel Motor2 Idle Volume	0	0000-0000
317	Q1L-052		Not Used	0	0000-0000
318	Q1L-053	52.13.0	Valve Rod Clank / Gas Turbine Whoosh Volume	11	0000-1011
319	Q1L-054	52.14.0	Turbo Idle Volume	0	0000-0000
320	Q1L-055	52.15.0	Cylinder Cocks / Gas Turbine Whine Volume	11	0000-1011
321	Q1L-056	52.16.0	Air Pump 1 Volume	11	0000-1011
322	Q1L-057	52.17.0	Air Pump 2 Volume (Steam Locos)	11	0000-1011
323	Q1L-058		Not Used	0	0000-0000
324	Q1L-059	52.19.0	Steam Blower Hiss / Cooling Fans Volume	8	0000-1000
325	Q1L-060	52.20.0	Snifter Valve Volume	0	0000-0000
326	Q1L-061	52.21.0	Long Air Let-Off Volume	11	0000-1011
327	Q1L-062	52.22.0	Short Air Let-Off Volume	11	0000-1011
328	Q1L-063		Not Used	0	0000-0000
329	Q1L-064	52.24.0	Squealing Brakes Volume	11	0000-1011
330	Q1L-065		Not Used	0	0000-0000
331	Q1L-066	52.26.0	Steam Dynamo / Diesel Generator Idle Volume	11	0000-1011
332	Q1L-067		Not Used	0	0000-0000
333	Q1L-068	52.28.0	Dynamic Brakes Fans Volume	0	0000-0000
334	Q1L-069	52.29.0	Boiler Pop-Off / Spitter Valve Volume	11	0000-1011
335	Q1L-070	52.30.0	Blow Down / Air Dryer Volume	11	0000-1011
336	Q1L-071	52.31.0	Injector Volume	11	0000-1011
337	Q1L-072	52.32.0	Fuel Sounds Volume (Coal Shovel+ Coal Auger)	11	0000-1011
338	Q1L-073		Not Used	0	0000-0000
339	Q1L-074	52.34.0	Coupler Sounds Volume	11	0000-1011

10.5 Printing Consist and Accessory Details

In most respects, Consists and Accessories are treated by the Print facility in exactly the same way as Locomotive (and Multiple) Items, and there is no difference in the way in which the Print Items window options are applied.

However, since Consist parameters are limited to a Description and an Address, and a Consist does not possess any Configuration Variables of its own, the Item Details printout is limited to a few lines on the first page, together with a list of the Assigned Locomotives and their active Addresses, as shown in the example below –

```

Item Descr : Switcher Consist #2
Type       : Consist           Flags       : Inactive  Saved   NotProg'md
Prim'y Addr : ===           Consist Addr : >120   Extend Addr : ====
Configur'n : Consist - see Assigned Locomotives for Configuration Parameters
Auto Stop  : ---             ---         ---         ---
BiDir Comms : ---           ---         ---         ---
Controller : None Allocated   Speed Steps : ===

Assigned Locomotives :

      Addr Dir Description
Lead  : 0464 F AT&SF GE44 Switcher - DN140
Mid1  : 0000 F No Locomotive Assigned
Mid2  : 0463 F AT&SF GE44 Switcher - DN135D
Mid3  : 0000 F No Locomotive Assigned
Mid4  : 0000 F No Locomotive Assigned
Rear  : 0436 R DRGW GE44 Switcher - DN135D
    
```

Similarly, if a Consist is included in a CSV Print File, a single information row is inserted in place of any CV values, with a note to refer to the Assigned Locomotives for the necessary CV data, as shown below –

	A	B	C	D	E	F	G	H
1								
2	C:\Users\User\Documents\A-Track Item Lists\AT-Tutorial-Demo-44-Consists.itl							
3	Printed : 13 Nov 2018							
4								
5	Cnst	>120	Switcher Consist #2					
6								
7			>>> Consist - See Assigned Locos for CV Values <<<					
8								
9								

Accessories have fewer parameters and defined Configuration Variables than Locomotives, so the first page of their Item Details printout contains much less data than that for a Locomotive. Rather than waste paper, if you select an option to print Accessory Configuration Variables, the list of CVs starts on the first page. With between 28 and 32 rows of CV data printed on this first page (depending on the number of Outputs possessed by the Accessory), the full CV list only occupies a further two pages (CV001 to CV128). Part of an example printout is shown below –

```

Item Descr : Pine Creek West - Lenz LS150
Type       : Accessory                Flags       : Inactive  Saved  NotProg'md
DecoderAddr : 0038                    Output Addr : >0151
Configur'n : Basic                    OutputAddr  NoBiDirCom

BiDir Comms : ---
Controller  : None Allocated
Manuf Versn : 000                    User ID #1  : 000
Manufac ID  : 000                    User ID #2  : 000
Manuf Prgrm : Yes                    NCE Decoder : No
Aux I/P Act : --      --      --      --      --      --      --      --
Time-On F1  : 000                    Time-On F2  : 000
Time-On F3  : 000                    Time-On F4  : 000
Num O'Puts  : 6                      Seqnl Adrs  : Yes
SnapItRechg : ===                    SnapIt Time : ===

Output Addr Name          Link Addr Name
00 0151 Silver Pass West  R 0144 GregsonSilver Siding
01 0152 CreekSand&Gravel West U 0000 Not Linked
02 0153 PineCreek Crossing West U 0000 Not Linked
03 0154 PineCreek Crossing East U 0000 Not Linked
04 0155 Maintenance      N 3155 O'GradyLthr - ForestFlat
05 0156 Not Used #3      U 0000 Not Linked

Accessory CV-Block (CVs 001 - 128)

CV-No Description                               Dec Binary
001 Address LS 6 Bits / Output Addr Mod 256    038 0010:0110
002 Auxiliary Input Activation of Outputs 1-8   000 0000:0000
003 Time On for Function F1 (NCE Switch-Kat)   000 0000:0000
004 Time On for Function F2                    000 0000:0000
005 Time On for Function F3                    000 0000:0000
006 Time On for Function F4                    000 0000:0000
007 Manufacturer Version Number                000 0000:0000
008 Manufacturer ID Number                     000 0000:0000
009 Address MS 3 Bits / Output Addr Div 256    000 0000:0000
010 Reserved by NMRA for future use            000 0000:0000
011 Reserved by NMRA for future use            000 0000:0000
    
```

Alternatively, if Item Details for an Accessory are printed to a CSV Print File, the format is essentially the same as that for a Locomotive or Multiple -

Item-Details-PineCreekWest-LS150-13-Nov-18.csv					
	A	B	C	D	E
1					
2	C:\Users\User\Documents\A-Track Item Lists\AT-Tutorial-Demo-44-181113.itl				
3	Printed : 13 Nov 2018				
4					
5	Acsy	>0151	Pine Creek West - Lenz LS150		
6					
7	Block-Ref	CV-No	Description	Dec	Binary
8	BSL-001	0-001	Address LS 6 Bits / Output Addr Mod 256	38	0010-0110
9	BSL-002	0-002	Auxiliary Input Activation of Outputs 1-8	0	0000-0000
10	BSL-003	0-003	Time On for Function F1 (NCE Switch-Kat)	0	0000-0000
11	BSL-004	0-004	Time On for Function F2	0	0000-0000
12	BSL-005	0-005	Time On for Function F3	0	0000-0000
13	BSL-006	0-006	Time On for Function F4	0	0000-0000
14	BSL-007	0-007	Manufacturer Version Number	0	0000-0000
15	BSL-008	0-008	Manufacturer ID Number	0	0000-0000
16	BSL-009	0-009	Address MS 3 Bits / Output Addr Div 256	0	0000-0000

However, only the Base Low CV Block (CV001 to CV128) is printed, regardless of how many CV Blocks are selected from the Print Items & Lists window options.

Note that, as described fully in **Sections 7, 7.3, and 7.5** most modern Accessory decoders do not use the NMRA-defined Configuration Variables, and are not designed to be programmed or verified using Service Mode when connected to a Program Track. Instead, they are normally programmed in Operations Mode via the Mainline Track, in conjunction with manual manipulation of direct electrical connections, jumpers, or switches on the decoder.

The exception is the range of Accessory decoders produced by NCE Corporation, which use a set of CVs to hold various options and parameters. The CVs in question will be printed on the second page of Item Details, as shown below –

Accessory CV-Block (CVs 001 - 128)		
CV-No	Description	Dec Binary
031	Indexed Page Address High Byte	000 0000:0000
032	Indexed Page Address Low Byte	000 0000:0000
033	NCE Switch-8 Reverse Output Polarity	000 0000:0000
034	Reserved for Manufacturer use	000 0000:0000
035	NCE Switch-It Enable Output Exercise	000 0000:0000
036	NCE Switch-It/Snap-It Enable Output A Toggle / Mk2 Decoders..	000 0000:0000
037	NCE Switch-It Enable Output B Toggle	000 0000:0000
038	NCE Snap-It Capacitor Recharge Time	000 0000:0000
039	Reserved for Manufacturer use	000 0000:0000
040	NCE Snap-It Output On Time	000 0000:0000
041	Reserved for Manufacturer use	000 0000:0000
042	NCE Switch-It/Snap-It Disable Legacy Ops Programming	000 0000:0000
043	Reserved for Manufacturer use	000 0000:0000
044	NCE All Decoders - Disable Pushbutton Inputs	000 0000:0000
045	Reserved for Manufacturer use	000 0000:0000
046	Reserved for Manufacturer use	000 0000:0000
047	Reserved for Manufacturer use	000 0000:0000
048	Reserved for Manufacturer use	000 0000:0000
049	NCE All Mk2 Decoders - Reverse Polarity Output 1	000 0000:0000
050	NCE All Mk2 Decoders - Reverse Polarity Output 2	000 0000:0000
051	NCE All Mk2 Decoders - Reverse Polarity Output 3	000 0000:0000
052	NCE All Mk2 Decoders - Reverse Polarity Output 4	000 0000:0000
053	NCE All Mk2 Decoders - Reverse Polarity Output 5	000 0000:0000
054	NCE All Mk2 Decoders - Reverse Polarity Output 6	000 0000:0000
055	NCE All Mk2 Decoders - Reverse Polarity Output 7	000 0000:0000
056	NCE All Mk2 Decoders - Reverse Polarity Output 8	000 0000:0000
057	Reserved for Manufacturer use	000 0000:0000
058	Reserved for Manufacturer use	000 0000:0000
059	Reserved for Manufacturer use	000 0000:0000
060	Reserved for Manufacturer use	000 0000:0000
061	Reserved for Manufacturer use	000 0000:0000
062	Reserved for Manufacturer use	000 0000:0000
063	Reserved for Manufacturer use	000 0000:0000
064	Reserved for Manufacturer use	000 0000:0000
065	NCE QSnap-Mk2 Output 1 On Time	000 0000:0000
066	NCE QSnap-Mk2 Output 2 On Time	000 0000:0000
067	NCE QSnap-Mk2 Output 3 On Time	000 0000:0000
068	NCE QSnap-Mk2 Output 4 On Time	000 0000:0000
069	Reserved for Manufacturer use	000 0000:0000
070	Reserved for Manufacturer use	000 0000:0000

Since no modern Accessory decoders support a connection to a Program Track, it is not possible to read and verify the state of their CVs and programmed parameters directly,

in order to load the data into an Item in the Item List, and then subsequently to produce a printout or print file like those shown above.

Details of Accessory Items will generally have to be created manually in an Edit CVs window, setting addresses and other parameters to correspond with the values sent or entered directly to the decoder, so that the data can then be safely saved to disk and/or printed.

10.6 Printing Route Macro Lists and AIU Allocations

When the appropriate files are loaded to A-Track, the contents of a Route Macro or AIU Allocation List can be printed using the same types of formatting as provided for Items and Item Lists, as described in **Sections 10.1** and **10.4**.

When printing a Route Macro List, the print options shown in the Print Items & Lists window, opened from the **Print** option in the **File** menu are as shown below –

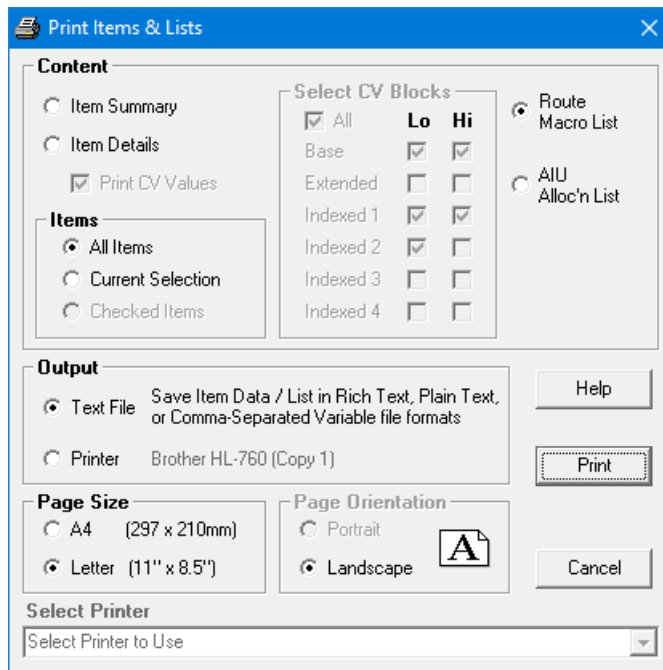

When the **Route Macro List** option is selected in the top right part of the window, you have the choice of printing all Macros by selecting **All Items** in the **Items** area, or only those Macros which are selected in the Route Macro Table by selecting **Current Selection**.

Note that, for the latter choice, the Route Macro table requires to be displayed *before Print* is actioned from the **File** menu, so that the appropriate Macros can be highlighted. If the required Macros are already highlighted, but the Route Macro Table is not presently displayed on the screen, or you wish to print all Macros, then there is no need to display the Route Macro Table before printing.

Although you can print to paper or to a file, and still have the choice of Page Size, the Page Orientation will always be Landscape so that each Macro can be printed completely within a single row. An example printout is shown below –

Macro Colour	Description	01	02	03	04	05	06	07	08	09	10
000	Green	Main-SilverPass-HighPeak	0152N	0107N	>011						
001	Green	Main-ForFlat-thruPineCrk	0153R	0154N	0101N	0102N	0103N	0104N	0105R	>019	
002	Yellow	ForestFlatW-FinePine #2	0153R	0154N	0101R	0108N	0121N				
003	Yellow	ForestFlatW-FinePine #1	0153R	0154R	0108N	0121N					
004	Yellow	ForestFlatW-HeathSaw #3	0153R	0154N	0101N	0102R	0122R				
005	Yellow	ForestFlatW-HeathSaw #4	0153R	0154N	0101N	0102N	0103R				
006	Orange	ForestFlatW-FnCrkStores	0153R	0154N	0101N	0102N	0103N	0104R			
007	Blue	ForestFlatW-Maintenance	0153R	0154N	0101N	0102N	0103N	0104N	0105N	0106R	
008	Green	ForestFlatW-ForestPlate	0153R	0154N	0101N	0102N	0103N	0104N	0105R		
009	Green	SlvrPass-HiPeak-viaPnCrk	0153N	0154N	0101N	0102N	0103N	0104N	0105N	0106N	0107R
											0152R
011	Red	SlvrPass-Thru-GregSilver	0141R	0151N	>016						
012	Red	GregsonSilver-Siding #1	0141N	0142R	0143R	0144N	0151R				
013	Red	GregsonSilver-Siding #2	0141N	0142N	0143N	0144N	0151R				
014	Red	GregsonSilver-Siding #3	0141N	0142R	0143R	0144R	0151N				
016	Green	Main-HighPeak-Thru	0131N	0132N	>019						
017	Green	Main-HighPeak-Passing	0131R	0132R							
019	Cyan	ForestFlat-Main-Thru	0201N	0202N	0203N	0204N	>008				
020	Cyan	ForestFlat-MainPassing	0201R	0202N	0203N	0204R					
022	Cyan	ForFlatWyeN-McGLmbr-N	0201R	0202R	0211N	0212N					
023	Cyan	ForFlatWyeS-McGLmbr-N	0204R	0203R	0221N	0222R	0212R				
024	Cyan	ForFlatWyeN-McGLmbr-S	0201R	0202R	0211R	0221R	0222N				
025	Cyan	ForFlatWyeS-McGLmbr-S	0204R	0203R	0221N	0222N					
030	White	Set All Normal - 1	0101N	0102N	0103N	0104N	0105N	0106N	0107N	0108N	>031
031	White	Set All Normal - 2	0121N	0122N	0131N	0132N	0141N	0142N	0143N	0144N	>032
032	White	Set All Normal - 3	0151N	0152N	0153N	0154N	>033				
033	White	Set All Normal - 4	0201N	0202N	0203N	0204N	0211N	0212N	0221N	0222N	
035	White	Set All Route - 1	0101R	0102R	0103R	0104R	0105R	0106R	0107R	0108R	>036
036	White	Set All Route - 2	0121R	0122R	0131R	0132R	0141R	0142R	0143R	0144R	>037
037	White	Set All Route - 3	0151R	0152R	0153R	0154R	>038				
038	White	Set All Route - 4	0201R	0202R	0203R	0204R	0211R	0212R	0221R	0222R	

Route Macro Table for Example Layout presented in Chapter 7

As well as printing any **Description** given to each Macro, the name of any **Background Colour** assigned to the Description of that Macro is also printed, for information, in the second column.

Note also that, where the Route Macro Table is not fully populated, details of any blank Macros are not printed, and that only a single blank row is printed regardless of the number of intervening (or following) blank Macros. In the example printout above, this can be seen in the gap between Macro 025 and Macro 030, and that no Macros are printed beyond Macro 038.

This is also the case where the Route Macro Table is printed to a CSV Print File, as shown below where, to improve readability, the widths of all columns have been adjusted and columns D to M have been centred –

Route-Macros-Demo44-14-Nov-18.csv													
	A	B	C	D	E	F	G	H	I	J	K	L	M
1													
2			C:\Users\User\Documents\A-Track Route Lists\RouteList-000-063-Demo-44-181114.rbk										
3			Printed : 14 Nov 2018										
4													
5	Macro	Colour	Description	1	2	3	4	5	6	7	8	9	10
6	0	Green	Main-SilverPass-HighPeak	0152N	0107N	>011							
7	1	Green	Main-ForFlat-thruPineCrk	0153R	0154N	0101N	0102N	0103N	0104N	0105R	>019		
8	2	Yellow	ForestFlatW-FinePine #2	0153R	0154N	0101R	0108N	0121N					
9	3	Yellow	ForestFlatW-FinePine #1	0153R	0154R	0108N	0121N						
10	4	Yellow	ForestFlatW-HeathSaw #3	0153R	0154N	0101N	0102R	0122R					
11	5	Yellow	ForestFlatW-HeathSaw #4	0153R	0154N	0101N	0102N	0103R					
12	6	Orange	ForestFlatW-PnCrkStores	0153R	0154N	0101N	0102N	0103N	0104R				
13	7	Blue	ForestFlatW-Maintenance	0153R	0154N	0101N	0102N	0103N	0104N	0105N	0106R		
14	8	Green	ForestFlatW-ForestFlatE	0153R	0154N	0101N	0102N	0103N	0104N	0105R			
15	9	Green	SlvrPass-HiPeak-viaPnCrk	0153N	0154N	0101N	0102N	0103N	0104N	0105N	0106N	0107R	0152R
16													
17	11	Red	SlvrPass-Thru-GregSilver	0141R	0151N	>016							
18	12	Red	GregsonSilver-Siding #1	0141N	0142R	0143R	0144N	0151R					
19	13	Red	GregsonSilver-Siding #2	0141N	0142N	0143N	0144N	0151R					
20	14	Red	GregsonSilver-Siding #3	0141N	0142R	0143R	0144R	0151N					
21													
22	16	Green	Main-HighPeak-Thru	0131N	0132N	>019							
23	17	Green	Main-HighPeak-Passing	0131R	0132R								
24													
25	19	Cyan	ForestFlat-Main-Thru	0201N	0202N	0203N	0204N	>008					
26	20	Cyan	ForestFlat-MainPassing	0201R	0202N	0203N	0204R						
27													
28	22	Cyan	ForFlatWyeN-McGLmbr-N	0201R	0202R	0211N	0212N						
29	23	Cyan	ForFlatWyeS-McGLmbr-N	0204R	0203R	0221N	0222R	0212R					
30	24	Cyan	ForFlatWyeN-McGLmbr-S	0201R	0202R	0211R	0221R	0222N					
31	25	Cyan	ForFlatWyeS-McGLmbr-S	0204R	0203R	0221N	0222N						
32													
33	30	White	Set All Normal - 1	0101N	0102N	0103N	0104N	0105N	0106N	0107N	0108N	>031	
34	31	White	Set All Normal - 2	0121N	0122N	0131N	0132N	0141N	0142N	0143N	0144N	>032	
35	32	White	Set All Normal - 3	0151N	0152N	0153N	0154N	>033					
36	33	White	Set All Normal - 4	0201N	0202N	0203N	0204N	0211N	0212N	0221N	0222N		
37													
38	35	White	Set All Route - 1	0101R	0102R	0103R	0104R	0105R	0106R	0107R	0108R	>036	
39	36	White	Set All Route - 2	0121R	0122R	0131R	0132R	0141R	0142R	0143R	0144R	>037	
40	37	White	Set All Route - 3	0151R	0152R	0153R	0154R	>038					
41	38	White	Set All Route - 4	0201R	0202R	0203R	0204R	0211R	0212R	0221R	0222R		

If you attempt to print a Route Macro List when one has not already been loaded into A-Track, then an error message will be displayed –

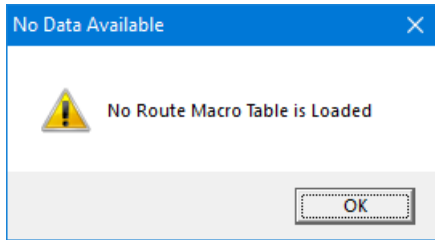

Click **OK** to close the Print Items & Lists window, load the appropriate Route Macro List file, and try the Print operation again.

Printing an AIU Allocation List follows similar steps to the process described above for a Route Macro List although, since the file structure is much simpler, there are fewer Print options available.

No selection is available, so the full Allocation List is always printed to paper or to file, and the Page Orientation is fixed at Portrait, although you do have a choice of Page Size, between A4 or Letter.

Where the relevant Accessory Items are included in the loaded Item List, a name will be printed for each turnout allocated to an Auxiliary Input Unit, and the current direction of each allocated turnout will also be included, as shown on the example printout shown below –

Auxiliary Input Unit : 08							
I/P	T/Out	Dir	Description	I/P	T/Out	Dir	Description
01	0101	N	FinePineFurn - Siding #2	08	0108	N	Siding #1 - East
02	0102	N	Heath Sawmill Siding #3	09	0121	R	FinePineFurn-Siding#2
03	0103	N	Heath Sawmill Siding #4	10	3121	N	FinePineFurn-Siding#3
04	0104	N	Pine Creek Stores	11	0151	R	Silver Pass West
05	0105	N	O'Grady Leather - Thru	12	0152	N	CreekSand&Gravel West
06	0106	R	Maintenance	13	0153	R	PineCreek Crossing West
07	0107	N	CreekSand&Gravel-East	14	0154	N	PineCreek Crossing East
 Auxiliary Input Unit : 09							
I/P	T/Out	Dir	Description	I/P	T/Out	Dir	Description
01	0201	N	Forest Flat Bypass North	08	3212	R	McGilligan North-West
02	0202	R	Forest Flat Wye North	09	0131	N	High Peak Passing North
03	0203	R	Forest Flat Wye South	10	0132	N	High Peak Passing South
04	0204	R	Forest Flat Bypass South	11	0141	N	Silver Pass East
05	0211	N	McGilligan South-East	12	0142	N	GregsonSilver East
06	0212	R	McGilligan South-West	13	0143	N	GregsonSilver West
07	3211	N	McGilligan North-East	14	0144	N	GregsonSilver Siding

Page 1 Printed : 14 Nov 2018 C:\Users\User\Do...\AIU-Allocation-15-Sep-18.abk

On large layouts which may use a considerable number of AIUs, the printout will accommodate five AIUs per page.

When printed as a CSV Print File the allocations are formatted in a single block, rather than as a pair of blocks when using the other print formats, as shown in the example below –

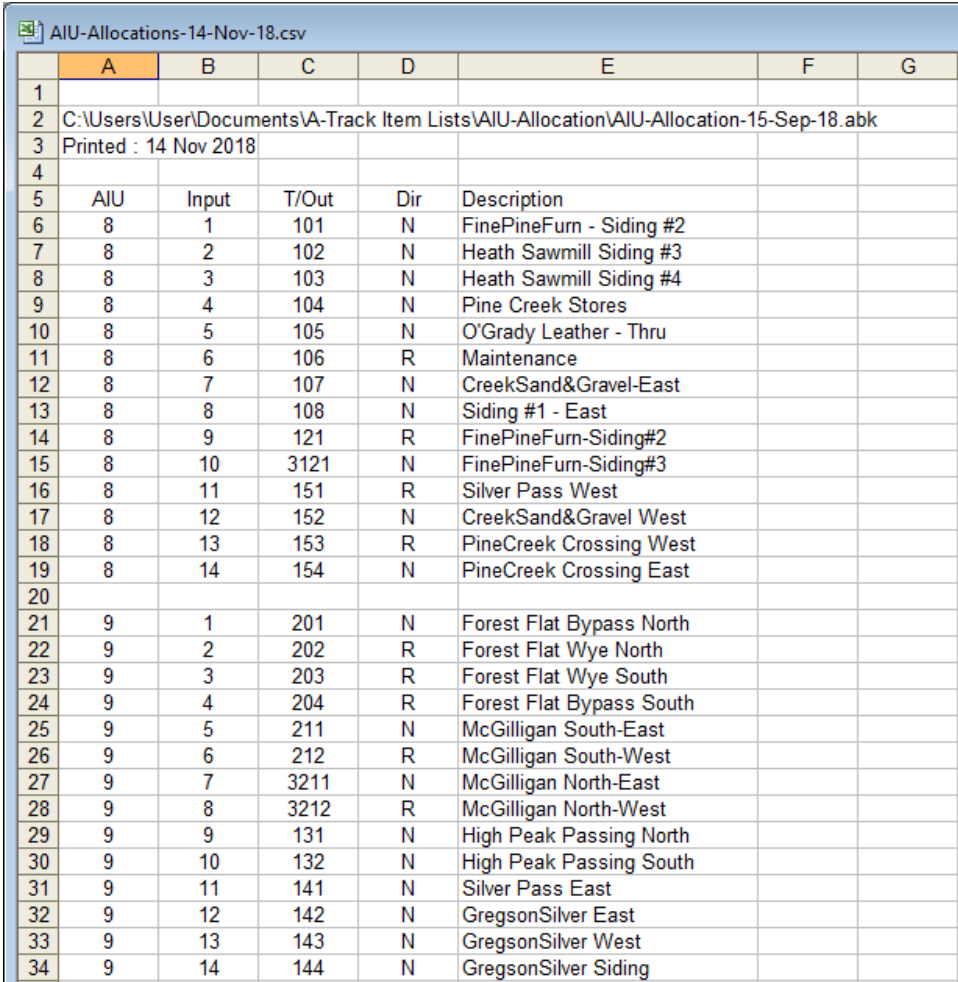

	A	B	C	D	E	F	G
1							
2	C:\Users\User\Documents\A-Track Item Lists\AIU-Allocation\AIU-Allocation-15-Sep-18.abk						
3	Printed : 14 Nov 2018						
4							
5	AIU	Input	T/Out	Dir	Description		
6	8	1	101	N	FinePineFurn - Siding #2		
7	8	2	102	N	Heath Sawmill Siding #3		
8	8	3	103	N	Heath Sawmill Siding #4		
9	8	4	104	N	Pine Creek Stores		
10	8	5	105	N	O'Grady Leather - Thru		
11	8	6	106	R	Maintenance		
12	8	7	107	N	CreekSand&Gravel-East		
13	8	8	108	N	Siding #1 - East		
14	8	9	121	R	FinePineFurn-Siding#2		
15	8	10	3121	N	FinePineFurn-Siding#3		
16	8	11	151	R	Silver Pass West		
17	8	12	152	N	CreekSand&Gravel West		
18	8	13	153	R	PineCreek Crossing West		
19	8	14	154	N	PineCreek Crossing East		
20							
21	9	1	201	N	Forest Flat Bypass North		
22	9	2	202	R	Forest Flat Wye North		
23	9	3	203	R	Forest Flat Wye South		
24	9	4	204	R	Forest Flat Bypass South		
25	9	5	211	N	McGilligan South-East		
26	9	6	212	R	McGilligan South-West		
27	9	7	3211	N	McGilligan North-East		
28	9	8	3212	R	McGilligan North-West		
29	9	9	131	N	High Peak Passing North		
30	9	10	132	N	High Peak Passing South		
31	9	11	141	N	Silver Pass East		
32	9	12	142	N	GregsonSilver East		
33	9	13	143	N	GregsonSilver West		
34	9	14	144	N	GregsonSilver Siding		

For improved readability, the values in columns A to D have been centred, and the width of column E has been increased.

Again, if you attempt to print an AIU Allocation List when one has not already been loaded into A-Track, you will see the following error message –

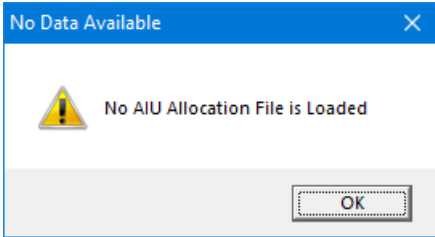

Click **OK** to close the Print Items & Lists window, load the appropriate AIU Allocation List file, and try the Print operation again.

11 REGISTRATION AND SUPPORT

A-Track is supplied for you to use free of charge, and support to fix any problems you may encounter when using A-Track will also be provided without charge. However, a great deal of time and effort has gone into the development of A-Track so that, if only to get some feedback that this effort has not been wasted, you are invited to register your copy (or copies) of A-Track.

Registration has the benefit that **registered users will receive priority** in resolving any problems they report, in attending to their requests for support, or in looking at the implementation of any additional features that they would like to have.

When A-Track is initially installed it is fully functional, with no restrictions placed on any of its facilities, and it will continue to operate in this way whether you choose to register or not. After installation, when you run A-Track, the initial window (as described previously in **Section 3.5**) will display an invitation to register for free priority support, as shown below, and this notice will continue to be displayed each time you start the program (until registered) –



11.1 Registration and Activation

If you wish to register A-Track, then click on **Help** on the menu bar and select **Register / Activate** from the drop-down menu –

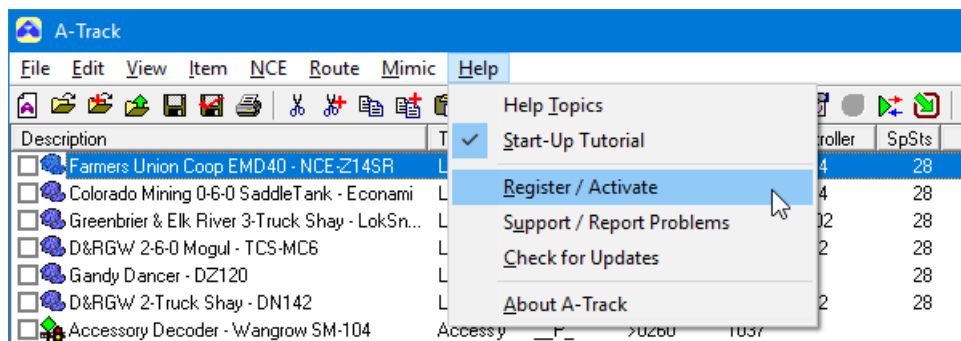

Clicking on Register / Activate will open a window displaying a basic set of instructions on how to proceed with registration and activation, together with two textboxes in

which to enter a **First** and **Last Name** under which this copy of A-Track will be registered.

Also displayed in the Register / Activate window is information relating to the **Version** of A-Track which is running, the **Serial Number** generated when you installed this copy of A-Track, details of the version and build of **Windows** installed on this computer, and the type and software version of the **NCE System** to which you last connected, including the version of **NCE USB Interface**, where used.

If the computer on which A-Track is running has an **active connection to the Internet** then you can proceed immediately to register your copy of the program.

Enter the first and last names that you wish to use for registration in the appropriate textbox. The names can be your own, or you can use the name of your club, for example, but each name must contain a minimum of 3 characters, up to a maximum of 20 characters. Any combination of characters can be entered except for an ampersand (&) which will be replaced with a '+' symbol.

Once both textboxes contain an acceptable name, the **Register Online** button will be enabled, as shown below –

A-Track Register / Activate

When installed, this version of A-Track for Windows is fully operational without any restrictions

Register for Priority Support

If this computer has an active Internet connection, you can obtain an activation key to qualify for priority product support by entering your First and Last Names below (each name must contain at least 3 and no more than 20 characters) and then clicking the Register Online button. Otherwise e-mail your two Names, the Serial Number, and System data displayed below to - register@a-train-systems.co.uk

Ensure the Names are entered exactly as used to register this copy of A-Track, then paste the activation key code provided into the Activation Key textbox below (or type it into the textbox without dashes or spaces) and click Activate

First Name

Last Name

Version 4.4.192 Serial Number 170407T0ECE24

System Windows 10 Enterprise

Build 17134.1.x86fre.rs4_release.180410-1804

NCE Power Cab Software Version 1.65B

USB Interface 7.3.3

Activation Key

If you do **not** wish to proceed with registration at this time, then you can click **Close** to remove the window. The two entered names will be saved and re-displayed next time you open the Register / Activate window, at which time you are free to make any changes to the names that you wish. Otherwise click **Register Online** to connect to the Internet and to the Registration page of the A-Train Systems website.

A-Track will copy your entered First and Last Names, together with the full set of information displayed in the Register / Activate window above, to the webpage, as shown below -



Model Railroad Electronics and Control

Home	Contact		Site Map		
A-TRACK	Get A-TRACK	Projects & DCC	Download	Links	About

Register Your Copy of A-Track -

Please ensure that both Names, the Serial Number, and your e-mail address below are completed accurately. If details of your A-Track version, Windows operating system type and build number, and NCE system type and software version have not been entered automatically, then please type into the System and NCE System Type fields the version of Windows and type of NCE Command Station, respectively, that you are using with A-Track (Build details and Software Version can be left blank although, if you are using an NCE USB Interface, it is useful to know if this is Version 6 or the newer Version 7). Finally, enter the 6-character security code (the numbers and letters on the coloured background), then click **Register** to register your copy of A-Track.

First Name

Last Name

A-Track Version

Serial Number

Your E-Mail Address

Confirm E-Mail Address

System

Build

NCE System Type

NCE Software/USB Version



Please enter Security Code

Note that A-Train Systems will not under any circumstances divulge your e-mail address to any other person or organisation, and will only use the address you have provided to send you your registration key and occasionally to inform you of any available updates to the A-Track software.

If you encounter any problems with registration or in using A-Track, please use the [Contact](#) form to request assistance.

[▲ Top of Page](#)

[◀ Home](#)

Copyright © JT Chamberlain 2004-2018 All rights reserved
All trademarks and logos used in these pages are the property of their respective holders
Page Last Updated 17 November 2018

Enter your **e-mail address** in each of the two textboxes below the displayed Serial Number, taking care to type the address correctly, and then enter the six characters

shown in the box with the multi-coloured background into the final **Security Code** textbox. The characters are selected from the numerals 0 to 9, and the uppercase letters A to F.

Finally, click the **Register** button to complete registration. Your entries will be checked for validity, and error messages will be displayed on the page if any entry is judged to be incorrect or inconsistent. If this occurs, simply correct the erroneous text, enter the **new** Security Code which will be displayed, and click **Register** again.

Once all entries are accepted, an Activation Key code will be generated and sent to the e-mail address which you provided, followed by an acknowledgement message as shown below. Note that A-Train Systems will never disclose your e-mail address to any other person or organisation, and will only use the address to send you the activation code, and occasionally to let you know if A-Track software updates are available.



Model Railroad Electronics and Control

Home		Contact		Site Map	
A-TRACK	Get A-TRACK	Projects & DCC	Download	Links	About

Thank You !

Your activation key has been e-mailed to you, and should arrive shortly in your Inbox

If you have any queries, or any comments to make about A-Track, good or bad, please use the [Contact](#) form to send a message

Donations are Welcome . . .

A-Track software and support are provided to you completely free of charge. However, if you have found A-Track of benefit to your model railroading activities, then you might like to contribute to the future development and upkeep of the program by making a donation. You can do this safely and securely via [PayPal](#), using any credit or debit card, even if you do not have a PayPal account. Click on the button below to proceed –

[Donate](#)

Copyright © JT Chamberlain 2004-2012 All rights reserved
All trademarks and logos used in these pages are the property of their respective holders
Page Last Updated 25 August 2012

Although the A-Track program and its on-going support are provided to you completely without charge, if you have found A-Track to be useful and a benefit in pursuing your model railroading activities, then you might like to consider making a donation to assist in the cost of maintaining the website and the equipment used to develop the software further.

You can donate any sum you wish, in a completely safe and secure manner, by clicking the **Donate** button shown above. This will connect you to the [PayPal](#) secure website where you can use any credit or debit card to make your donation, even if you do not have a PayPal account of your own. Any amount you choose to contribute will be gratefully received.

If the computer on which you run A-Track is not connected to the Internet, then you can register A-Track manually by going to the Registration webpage at <https://www.a-train-systems.co.uk/register.php> from any computer which does have an Internet

connection. Carefully enter your First and Last Names (each name must contain a minimum of 3 characters, up to a maximum of 20 characters), together with the installed program Serial Number, as displayed in the Register / Activate window (170407T0ECE24 in the example), complete the type of Windows and NCE System you are using, as far as you can (Build and NCE Software/USB Version can be left blank, although it is useful to know whether any USB Interface used is Version 6 or the newer Version 7), and click the **Register** button to receive your Activation Key.

Alternatively, you can register your copy of A-Track by sending an e-mail to register@a-train-systems.co.uk with your First and Last names together with the Serial Number and the other data. In this case, every effort will be made to return an Activation Key to you within 48 hours.

The automated e-mail message sent from the website with your registration details will look similar to the example shown below –

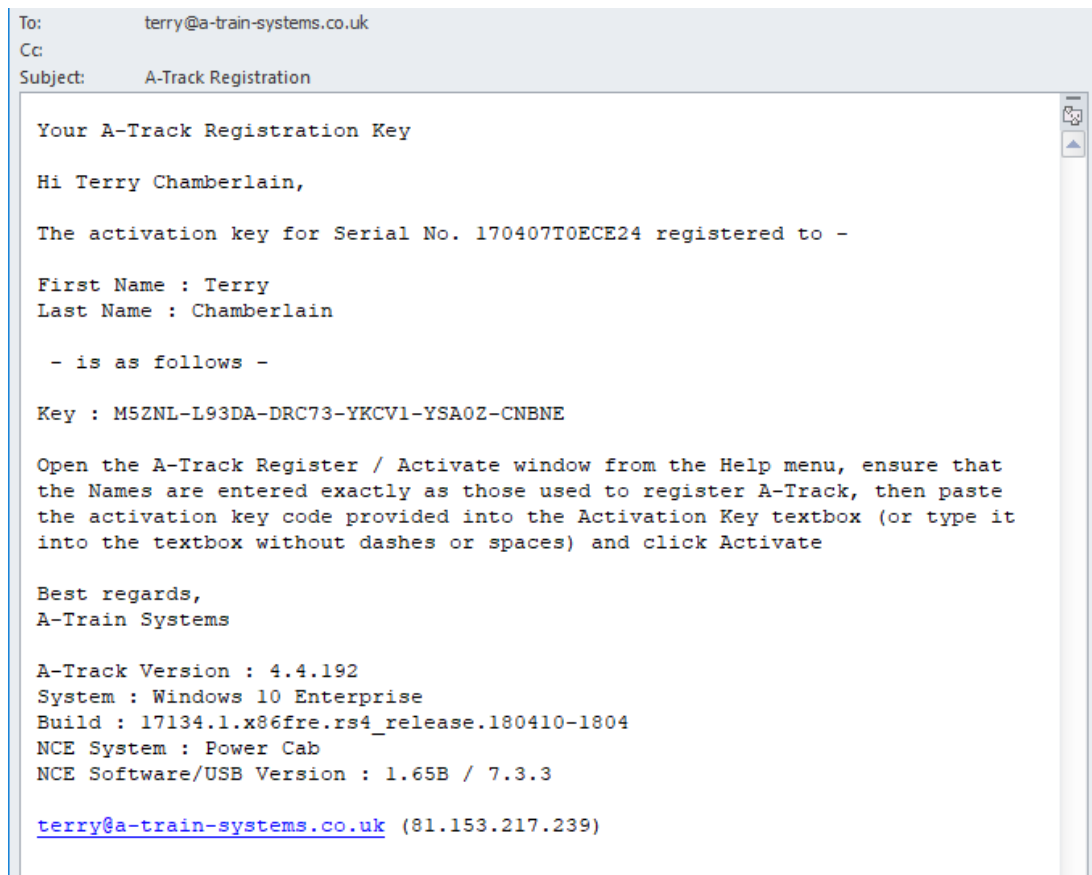

Once you obtain the e-mail containing the Activation Key, open the Register / Activate window once more (unless it is still open from when you started the Registration process). Check that the names you submitted for registration are displayed correctly in the **First Name** and **Last Name** textboxes, then enter the supplied activation code into the **Activation Key** textbox.

The Activation Key code consists of six groups of five characters (letters and numbers) separated by dashes. The letters 'I' and 'O' are not used so that they cannot be confused with the numbers '1' and '0' (which may appear). Letters can be typed in either lower or upper case, and there is no need to type the separating dashes – they

will be inserted automatically as you enter the characters of the Key. If you type either of the characters 'I' or 'O' (or 'i' or 'o') they will be translated to '1' or '0'.

Take care to enter the Activation Key accurately since even a single error will not be accepted. The safest way to enter the Activation Key (and the First and Last Names, if necessary) is to copy the value(s) from the text of the e-mail you receive, and then paste the copied text into the relevant textbox. When the registration information has been entered, the **Activate** button will be enabled, and should be clicked to complete the process –

Assuming that the entered names and Activation Key are correct, the program status will be updated to **Activated**, with a confirmation of success message displayed (in **green** text) below the Activation Key textbox –

Note that the date of registration is now shown in the top left part of the Register / Activate window (above a **green tick** icon) and that the Issue letter in the Serial Number (the seventh character) has changed from 'T' to 'A' to indicate the new program status.

Click **Close** to remove the Register / Activate window from the screen.

After activation, each time you start A-Track, the start-up window will show that the program is registered to yourself (or whichever name was used in the registration / activation process) –



If during activation, the Activation Key is entered incorrectly then, rather than a successful response, you will see a message (in **red**) to say that the Key is invalid –

Carefully check and re-enter your data, ensuring that both First and Last Names are entered exactly as they were submitted for registration, including any spaces or other punctuation, and that all characters of the Key are correct (as they are not in the example above), then click the **Activate** button again.

If activation fails again, the simplest remedy is to repeat the complete registration process, taking even more care that all text is entered accurately, to generate a fresh Activation Key and try again. In case of continued difficulty, please contact A-Train Systems for assistance (see below and **Section 11.2**).

Key Points to Note about Registration / Activation

While you are free to install as many copies of A-Track on different computers as you wish without charge, each installation will generate a unique serial number and will require to be separately registered and activated.

Once an A-Track installation is registered, the details are locked, and you cannot change the name of the Registered User nor the value of the Activation Key. If this creates a problem at any time in the future, then contact A-Train Systems for assistance (see below).

After registering A-Track on a particular computer, if you uninstall A-Track and then subsequently re-install the program, details of your registration / activation are retained in the Windows Registry so that the new installation of A-Track will still be registered. This will also be the case if you install a later, updated version of A-Track, although it is possible that some future major revision of the software may require re-registration.

However, if you perform any major upgrade or re-installation of software on your machine, particularly if you upgrade the Windows operating system, it is possible that the A-Track registration / activation information will be lost in the process. In this case, simply repeat the registration process to obtain a new activation key.

If you encounter any unusual difficulties regarding A-Track registration (or any other aspect of the program) then you should contact A-Train Systems either by submitting a Support Request, as described in the following **Section 11.2**, or through the [Contact](#) page on the website. You can also get in touch directly via e-mail by sending a message to support@a-train-systems.co.uk.

11.2 Obtaining Support and Reporting Problems

Although every effort has been made to test A-Track as fully as possible, and to make the program as resilient as possible, it is impracticable to predict every situation under which the software will operate, especially given the complexity of modern computer operating systems, or to eliminate every last bug and error in the program code (and any programmer who declares otherwise is seriously deluded !).

Hence, if you find that A-Track does not behave as you expect under some circumstances (or even crashes), then you are encouraged to submit a Support Request or Problem Report, by clicking on **Help** on the menu bar and then selecting the **Support / Report Problems** option from the drop-down menu –

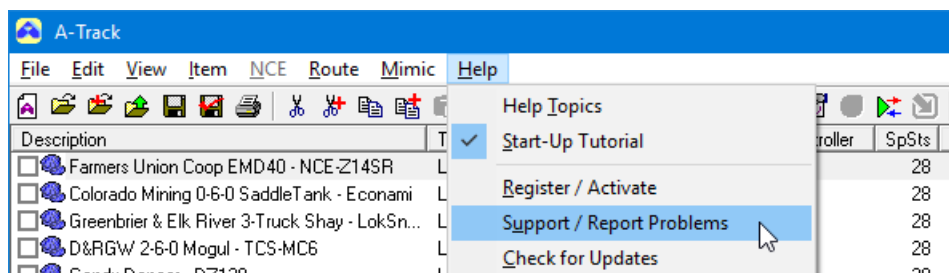

Clicking on Support / Report Problems will open a window displaying a basic set of instructions on how to proceed with sending a request for support or assistance to A-Train Systems. If the computer on which A-Track is running has an **active connection to the Internet** then you can proceed immediately to submit your support request.

Enter a name in the **Your Name** textbox in the displayed window. The name can be your own, or you can use the name of your club, for example. Any combination of characters can be entered except for an ampersand (&) which will be replaced with a '+' symbol. If you have previously registered this copy of A-Track, the Registered User Name will be entered automatically into the textbox (and can be edited if you wish) –

A-Track - Request Support or Report a Problem

 Like the A-Track software application, technical support to resolve any problems is available completely free of charge

Priority, however, will be given to registered A-Track users

If this computer has an active Internet connection, you can submit a request for support, or report a problem you have encountered, directly by entering your Name below and then clicking the Request Support button

Otherwise, from a computer which has Internet access, visit the A-Train Systems Support page at <http://www.a-train-systems.co.uk/support.php>, and enter your Name, plus the A-Track Version & Serial Number and System details as shown below, together with details of the support required. As a final option, you may also submit the same information by e-mail to support@a-train-systems.co.uk

Your Name

Version	4.4.192	Serial Number	170407A0ECE24
		Registered	22-Nov-18
System	Windows 10 Enterprise		
Build	17134.1.x86fre.rs4_release.180410-1804		
NCE	Power Cab	Software Version	1.65B
		USB Interface	7.3.3

If you do **not** wish to proceed with your request at this time, then you can click **Close** to remove the window. Otherwise click **Request Support** to connect to the Internet and to the Support page of the A-Train Systems website.

A-Track will copy your entered Name, together with the **Version** and **Serial Number** of the installed A-Track program (displayed in the Support / Report Problems window above as 4.4.192 and 170407A0ECE24, registered 22-Nov-18), details of the version and build of **Windows** installed on this computer, and the type and software version of the **NCE Command Station** to which you are currently connected (if any), including the version and settings of any **NCE USB Interface** last used, to the Support webpage where you can complete your request / report details, as shown in the example on the following page –



Model Railroad Electronics and Control

Home		Contact		Site Map	
A-TRACK	Get A-TRACK	Projects & DCC	Download	Links	About

Request Support or Report a Problem with A-Track -

If you encounter any problems in using A-Track, such as when the program does not behave in the way you expect or produces an incorrect result, then please use the form below to send full details. It would be very much appreciated if you could carefully check the User Guide, Reference Manual, or Help pages before reporting a problem, just in case you have misinterpreted the way in which A-Track is supposed to work . . .

Every request or problem will be investigated and you will get a response as soon as possible. Where appropriate, any necessary modifications or corrections will be incorporated in a future release of A-Track, and you will be informed when this has been done.

Priority will be given to requests for support or problem resolution from registered A-Track users.

You are also very welcome to propose any improvements you would like to see in the way A-Track operates, or in the features or facilities provided by the program.

Please ensure that your Name, A-Track Version and Serial Number, and your e-mail address below are completed accurately. If details of your Windows operating system type and build number, or of your NCE system and software version, have not been entered automatically, then please type into the System and NCE System Type fields the version of Windows and type of NCE Command Station, respectively, that you are using with A-Track (Build details and Software Version can be left blank although, if you are using an NCE USB Interface, it is useful to know if this is Version 6 or the newer Version 7). Finally, enter the 6-character security code (the numbers and letters on the coloured background), then click **Submit** to send your support request or problem report -

Your Name

A-Track Version

Serial Number

Your E-Mail Address

Confirm E-Mail Address

System

Build

NCE System Type

NCE Software/USB Version

Subject

Request / Report Details



Please enter Security Code

Send a copy to yourself

Note that A-Train Systems will not under any circumstances divulge your e-mail address to any other person or organisation, and will only use the address you have provided to acknowledge your support request and to inform you of any consequent updates to the A-Track software.

If you have any other comments regarding A-Track or anything else on the website, then you are very welcome to forward them using the [Contact](#) form.

[▲ Top of Page](#)

[◀ Home](#)

As noted in the introductory text on the Support webpage, before you submit a request for help with a problem, it would be very much appreciated if you could carefully check the relevant sections of this Reference Manual (or the A-Track Help Topics), just in case you have misinterpreted the way in which A-Track is supposed to work. That said, if you are unhappy, for any reason, with the way A-Track handles your requirements, please go ahead and submit the details of the problem.

Enter your **e-mail address** in each of the two textboxes below the displayed Serial Number, taking care to type the address correctly, complete the **Subject** and **Details** textboxes, and then enter the six characters shown in the box with the multi-coloured background into the final **Security Code** textbox. The characters are selected from the numerals 0 to 9, and the uppercase letters A to F.

If you would like a copy of your submitted request / report to be e-mailed to you for your own records, click to tick the **Send a copy to yourself** checkbox. Finally, click the **Submit** button to complete the request process. Your entries will be checked for validity, and error messages will be displayed on the page if any entry is judged to be incorrect or inconsistent. If this occurs, simply correct the erroneous text, enter the **new** security code which will be displayed, and click **Submit** again.

Once all entries are accepted, an acknowledgement message will be displayed as shown below. Your problem will be investigated and a reply sent to you as soon as possible with, hopefully, a solution. All corrections will be incorporated in a future A-Track release, and registered users will be notified when such updates are available.

Note that A-Train Systems will never disclose your e-mail address to any other person or organisation, and will only use the address, on occasion, to acknowledge your submitted request, and to let you know when an applicable A-Track software update is available.



Model Railroad Electronics and Control

Home		Contact		Site Map	
A-TRACK	Get A-TRACK	Projects & DCC	Download	Links	About

Thank You !

Your support request / problem report has been sent.

Every request or problem will be investigated and you will get a response as soon as possible. Where appropriate, any necessary modifications or corrections will be incorporated in a future release of A-Track, and you will be informed when this has been done.

Thank you again for your interest in A-Track.

Donations are Welcome . . .

A-Track software and support are provided to you completely free of charge. However, if you have found A-Track of benefit to your model railroading activities, then you might like to contribute to the future development and upkeep of the program by making a donation. You can do this safely and securely via [PayPal](#), using any credit or debit card, even if you do not have a PayPal account. Click on the button below to proceed –



Copyright © JT Chamberlain 2004-2018 All rights reserved
 All trademarks and logos used in these pages are the property of their respective holders
 Page Last Updated 20 November 2018

Although the A-Track program and its on-going support are provided to you completely without charge, if you have found A-Track to be useful and a benefit in pursuing your model railroading activities, then you might like to consider making a donation to assist in the cost of maintaining the website and the equipment used to develop the software further.

You can donate any sum you wish, in a completely safe and secure manner, by clicking the **Donate** button shown above. This will connect you to the [PayPal](#) secure website where you can use any credit or debit card to make your donation, even if you do not have a PayPal account of your own. Any amount you choose to contribute will be gratefully received.

If the computer on which you run A-Track is not connected to the Internet, then you can access A-Track Support manually by going to the A-Train Systems Support webpage at <https://www.a-train-systems.co.uk/support.php> from any computer which does have an Internet connection.

Carefully enter your Name together with the installed program Version (4.4.192 in the example - see **Help / About** or **Help / Support**), and the Serial Number plus date of registration (170407A0ECE24 and 22-Nov-18 in the example - see **Help / Register** or **Help / Support**), complete the other entries as shown previously, and click the **Submit** button to complete your support request or problem report.

Alternatively, you can submit a support request or problem report via an e-mail to support@a-train-systems.co.uk containing full details together with your name, the program Version, and the installed Serial Number. In this case, every effort will be made to return an acknowledgement (although not necessarily a solution) to you within 48 hours.

As well as reporting errors and problems that you have found with any part of the software, you are also very welcome to propose any improvements that you would like to see in the way A-Track operates, or any additional features or facilities that you feel would increase the usefulness of the program. To make any suggestions, please use the Support Request / Problem Report form.

11.3 Checking for A-Track Updates

Although there is no specific plan to update A-Track on a continuous basis, new versions of the program will be produced from time to time, either to fix revealed errors or reported problems, or to incorporate additional or extended features suggested by users.

If you have an active Internet connection from your computer, you can check whether an update is available by opening the **Help** menu from the menu bar and then clicking on the **Check for Updates** option –

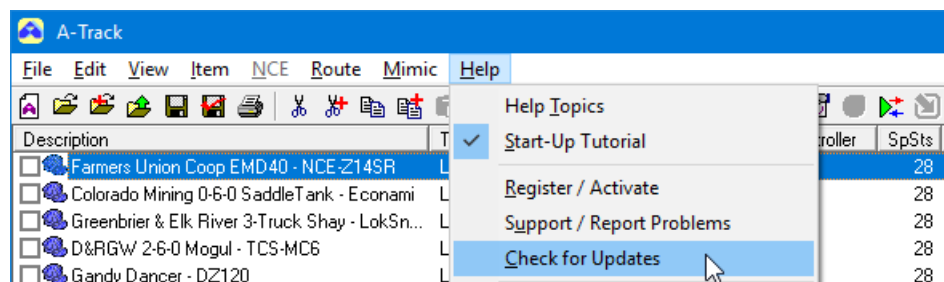

This displays the **Check for A-Track Updates** window showing which version of A-Track is currently installed together with a set of options which you can use to control when A-Track will automatically check for any available updates. As can be seen below, the option to check every time A-Track is started (**At Program Start**) is selected –

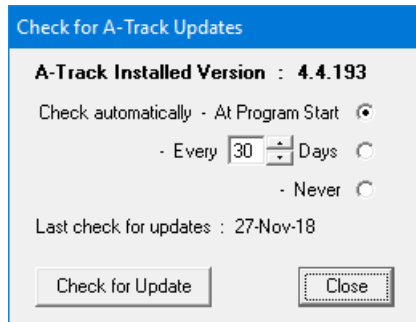

Alternatively, you can select the second option for A-Track to check for updates at fixed intervals. This is presently set at **Every 30 Days**, but you can set the interval at any value between 1 and 99 days, either by using the Up or Down buttons to the right of the textbox to increment or decrement the value in the textbox, or simply by clicking in the textbox to highlight its contents, then typing in the number of days required.

The final option **Never**, when selected, stops any automatic check for updates by the A-Track program at any time.

When A-Track is started for the first time, after being installed, it will check for any available update (and offer to download it, if found) and then set the automatic check interval to Every 30 Days, with the second option above being selected.

Regardless of the automatic check setting, you can, of course, check for an update at any time by opening the Check for A-Track Updates window as above, then clicking the **Check for Update** button.

After connecting to the A-Train Systems website, if you have the latest version of A-Track then a message to this effect will be displayed –

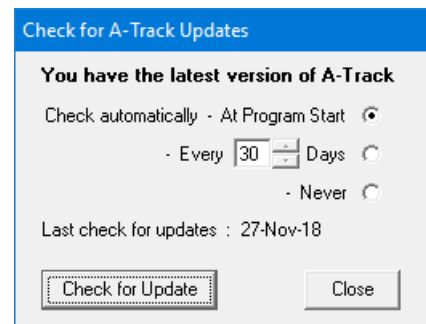

However, if an update is available, you will see the appropriate message, and the Check for Update button will be replaced by two buttons, **Download** to start download of the updated version, and **Details** which will allow you to review what has changed from the previous version –

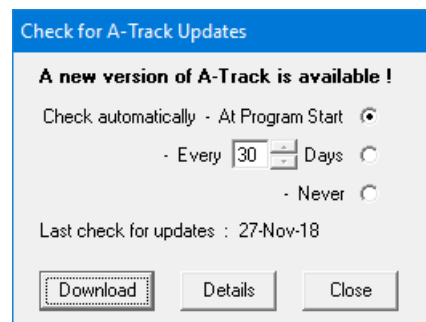

Clicking **Details** opens a message panel which presents a summary of the revisions made to A-Track in this new release –

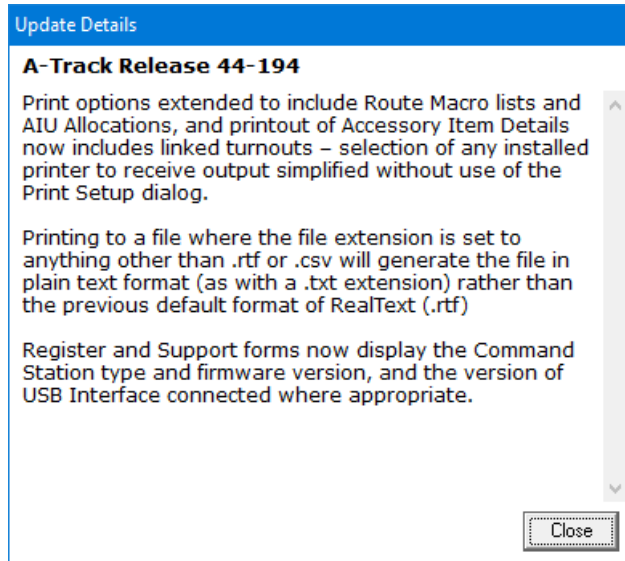

Click **Close** to remove the message panel from the screen.

Clicking **Download** will first open a standard Save As dialog, and give you the opportunity to save the new version of A-Track to whichever folder you choose. As an aid, A-Track will automatically create a folder named **A-Track Downloads** located as a subfolder within your main **Documents** (or **My Documents**) folder –

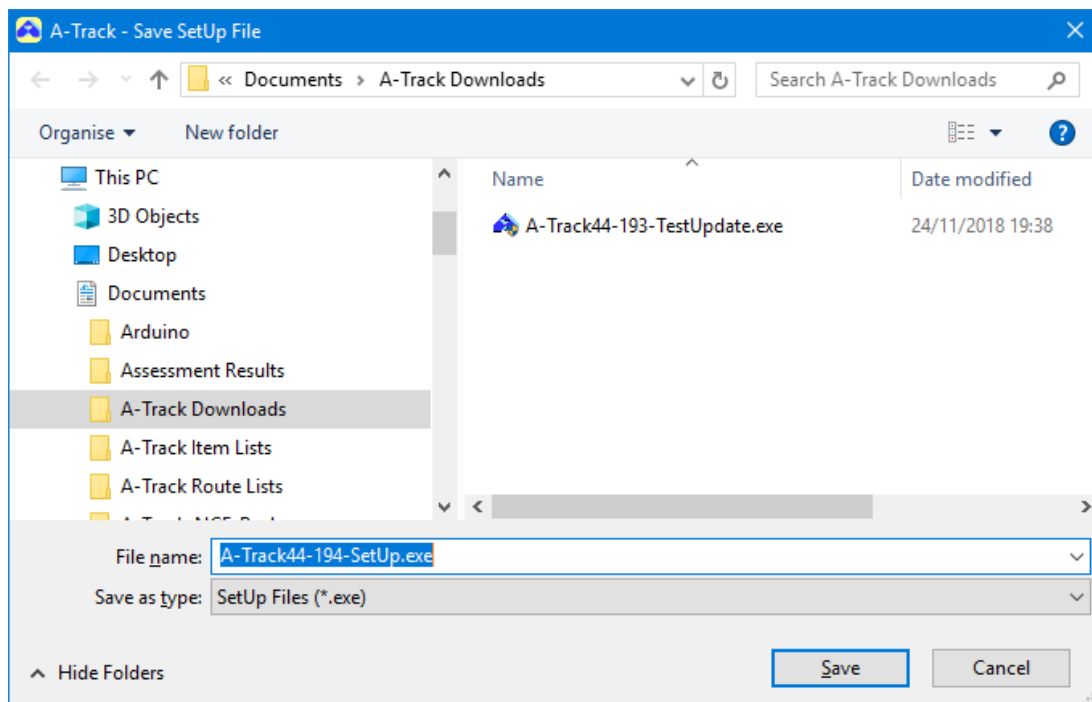

If you wish to save the A-Track SetUp file elsewhere, then select the required folder in the left pane above before clicking **Save** to save the file about to be downloaded in the selected folder. Otherwise, leave the selected folder at A-Track Documents, as shown above, and simply click **Save**.

Downloading of the A-Track SetUp file will then proceed at whatever speed is supported by your Internet connection at that time. Note that the file size will be between 36 and 40 Mbytes so that the transfer will take, for example, between 4 and 6 minutes with a connection speed of 10 Mbps.

Progress of the download will be shown in the Check for A-Track Updates window, as shown at the right –

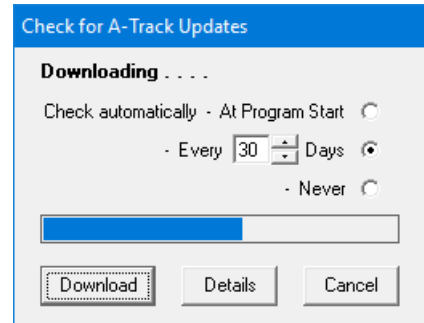

When download of the A-Track SetUp file is complete, you will see a reminder recommending that the current version of A-Track is uninstalled before installing the new version (see **Section 3.4** for further information) –

All A-Track settings, including your registration / activation details will be preserved and applied to the new version once installed.

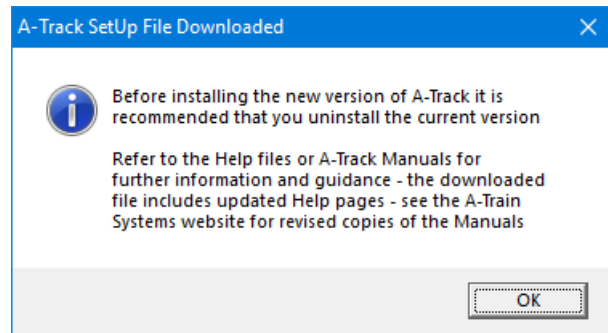

If A-Track is set up to check for updates automatically then, at the appropriate time (every 30 days by default) you will see a couple of additional messages appearing during the normal A-Track initialisation sequence –



The second message ('.. Connected') will only appear, of course, if you have an active Internet connection. Then, if no update is available at this time, or the connection to

the A-Train Systems website is not made within 10 seconds, the message will simply disappear, leaving A-Track initialisation to complete as usual.

However, if a new version of A-Track is available, you will be asked whether you wish to view details of revisions have been incorporated, with an option to then download the file, at this time –

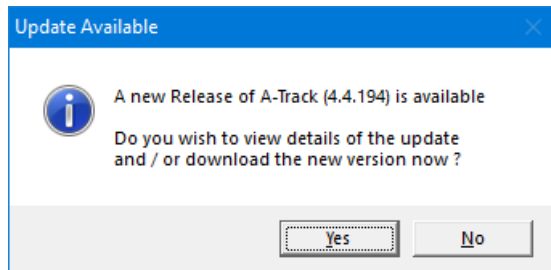

Clicking **No** will simply dismiss the message and let A-Track continue as usual, whereas clicking **Yes** will take you to the Check for A-Track Updates window where you can proceed directly to download the file, as described earlier in this Section –

Note that the normal A-Track initialisation will continue while this window is displayed, but will be paused if you proceed with the file download. To avoid any possible complications, it is probably best to allow initialisation, and download of Handheld Cab status, etc., to complete *before* clicking **Download** to retrieve the new A-Track SetUp file.

On the other hand, if you decide that you do not want to proceed with the download operation at this time, then just click the **Close** button to stop Internet access and remove the Check for A-Track Updates window from the screen.

If you do download the new version of A-Track, but do not install it immediately, then with the automatic update check still set at **At Program Start**, the same **Update Available** alert will appear the next time you start A-Track. It may be useful, therefore, to select the second option in the Check for A-Track Updates window, **Every 30 Days**, *before* clicking **Download** to proceed with the file transfer. This will postpone any further update alert for a month. On the other hand, clicking the **Close** button (whose caption has changed to **OK**) will simply save the new check interval before closing the window –

Note that you can make such adjustments to the frequency of automatic update checks at any time the Check for A-Track Updates window is open, even if you do nothing else. Just click **OK** to close the window and save your new setting.

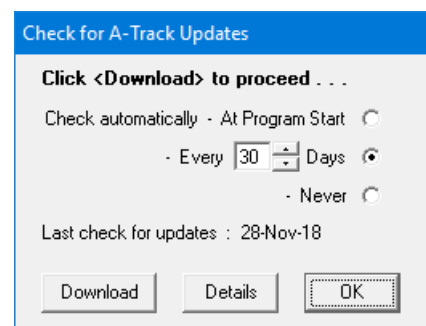
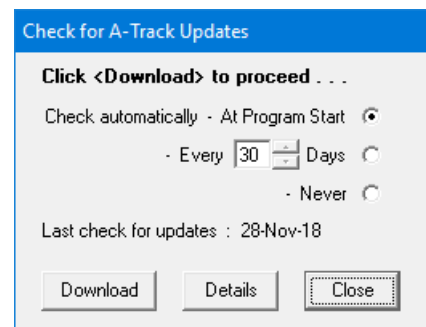

When the **A-Track – Save SetUp File** dialog is displayed after clicking **Download**, if you click **Cancel** rather than **Save** then you will be returned to the Check for A-Track Updates window –

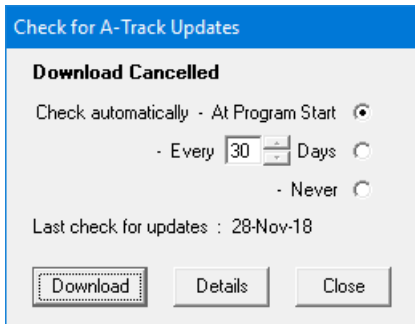

Here you have the choice of clicking **Download** to make a further attempt at downloading the file, or **Close** to remove the Update window from the screen.

Note that clicking **Cancel** when the download is actually in progress will cancel the file transfer completely, and immediately remove the Update window from the screen, without the option of restarting the file download –

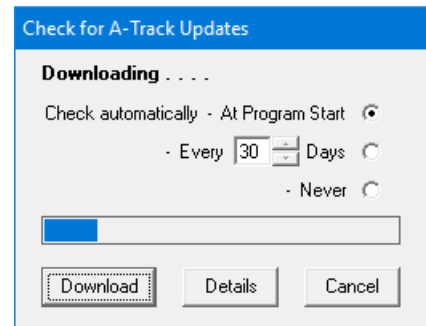

12 A-TRACK MENUS - REFERENCE

A description is provided in the following sections of the specific action performed by clicking each entry in each of the A-Track menus, including a note of any defined keyboard shortcut, ie. the key, or combination of keys, which can be pressed to perform that menu action immediately, together with any corresponding icon on the A-Track toolbar.

Rather than using the mouse, all menus and menu items can also be activated from the keyboard by using the specified **access keys**. The appropriate access key for each menu on the menu bar is underlined when the *left Alt* key is pressed. Pressing the underlined (initial) letter while keep the left Alt key held down will display the appropriate menu, eg. **Alt-F** to show the File menu – then release both keys.

Any desired item on the displayed menu can then be invoked by pressing the letter key corresponding to the underlined character in the name of that menu item, eg. with the File menu shown, pressing the **M** key will activate an Open Merge operation (which, in passing, also has a direct shortcut key of **Ctrl-M**, ie. hold down either Control (Ctrl) key then press the M key).

While the menu access keys will always be displayed when the *left Alt* key is pressed, they may or may not appear underlined while A-Track is running normally, depending on your computer's system settings. If you wish to see the access keys at all times then you need to change one of the Windows display parameters as follows.

In Windows XP, right-click on an empty area of the Desktop then, on the pop-up menu, click Properties. In the Display Properties window click on the Appearance tab and then on the Effects button. Untick the checkbox labelled 'Hide underlined letters for keyboard navigation until I press the Alt key'. Access keys will be shown thereafter on the menus and menu bars of all applications.

In Windows Vista, Windows 7, and Windows 8, right-click on an empty area of the Desktop then, on the pop-up menu, click Personalize. In the window which opens click on the Ease of Access link (bottom-left) and then on the 'Make the keyboard easier to use' link (you may have to scroll down to find this link). In the next window which appears, scroll down (again) to locate the entry 'Make it easier to use keyboard shortcuts', tick the checkbox labelled 'Underline keyboard shortcuts and access keys', click Save in Windows Vista, or OK in Windows 7 and Windows 8, and end by closing all open windows. Access keys will be shown underlined thereafter on the menus and menu bars of all applications.

In Windows 10 (starting with the Fall Creators Update – Version 1709) open Settings (⚙️) from the Start Menu or Start Screen, select Ease of Access then, in the left pane, scroll down and click on Keyboard. In the right pane, scroll down to find 'Change how keyboard shortcuts work' and ensure that 'Underline access keys when available' is set to On. Access keys will be shown underlined thereafter on the menus and menu bars of all applications.

12.1 File

New – Opens a new Item List containing a single Blank Item. If an Item List is already loaded and has been changed in any way, then you are asked whether you wish to save the current Item List before it is replaced with the new List.

Shortcut Key : **Ctrl-N** Toolbar Icon : 

Open – Opens an existing Item list. A standard Windows Open File Dialog is displayed, allowing you to navigate to the folder where the target Item List is held. If an Item List is already loaded and has been changed in any way, then you are asked whether you wish to save the current Item List before it is replaced with the selected Item List.



Shortcut Key : **Ctrl-O** Toolbar Icon : 

Open Merge - Opens an existing Item list and adds its constituent Items to the end of the currently displayed Item List. A standard Windows Open File Dialog is displayed, allowing you to navigate to the folder where the Item List to be merged is held.

Shortcut Key : **Ctrl-M** Toolbar Icon : 

Close – Closes the currently open Item List and removes it from display. If the Item List has been changed in any way, then you are asked whether you wish to save the current Item List before it is closed.

Auto Load Item List – Enables or disables an option to be open the last-opened Item List automatically each time A-Track is started (eliminating the need to open that Item List manually each time after starting the application). The menu entry shows a tick mark when the auto-load option is enabled.

Shortcut Key : None Toolbar Icon :  (Enabled) or  (Disabled)

Save As – Saves the currently open Item List to permanent storage. A standard Windows Save File Dialog is displayed, allowing you to navigate to the drive and folder where the current Item List is to be saved. You can either enter a new filename under which to save the Item List, or click Save to save the List under its existing filename. If you choose the latter option then you are asked to confirm that you wish to overwrite the previous version of the Item List.

Shortcut Key : **Ctrl-S** Toolbar Icon : 

Save Checked – Saves only those Items in the open Item List which are checked, ie. where the checkbox to the left of the Item Description is ticked, to permanent storage. A standard Windows Save File Dialog is displayed, allowing you to navigate to the drive and folder where the current Item List is to be saved. You can either enter a new filename under which to save the Item List, or click Save to save the List under its existing filename. If you choose the latter option then you are asked to confirm that you wish to overwrite the previous version of the Item List.

Note : By choosing to overwrite the existing Item List you will *permanently lose* all those Items which were *not* checked – so make sure that you really want to eliminate them, or have another copy stored safely elsewhere.



Shortcut Key : None Toolbar Icon : 

Properties – Displays details of the currently-open Item List file including file format, folder location, file size, number of Items, and the dates of creation and last modification.

Combo Data Restore Setup – Provides a facility to load a previously stored copy of Command Station parameters, including Handheld Cab locomotive allocations, Consist definitions and Macros, when using a Version 1.65 Power Cab or Smart Booster, or a DCC Twin, which do not retain parameters defined by A-Track after power-off. Includes provision to enable automatic loading of the specified file each time A-Track is started (eliminating the need to restore Command Station parameters manually each time after starting the application). The menu entry shows a tick mark when the auto-load option is enabled.

Auto Load AIU Allocation – Enables or disables an option to load a previously defined allocation of turnouts to connected Auxiliary Input Units automatically each time A-Track is started (eliminating the need to open that AIU Allocation List manually each time after starting the application). The menu entry shows a tick mark when the auto-load option is enabled.

Shortcut Key : None

Toolbar Icon :  (Loaded) or  (Unloaded)

Print – Allows you to print all or part of the Item List, details of selected Items, a Route MacroList, or an AIU Allocation List to any printer selected from those installed on the computer or accessible via the local network, or to an output file, and to select the basic print format and characteristics that you require.

Shortcut Key : **Ctrl-P**

Toolbar Icon : 

Most Recently Used Files – Shows the filenames of the most-recently opened Item Lists. Click on any displayed name to open the corresponding Item List. Up to eight filenames can be displayed in the list – when you open the ninth distinct Item List then the oldest filename is dropped from the list to make way for that of the latest Item List.

Exit - Closes any currently open Item List, and removes it from display, before terminating the A-Track program. If the Item List, details of selected Items, or loaded Route Macro List have been changed in any way, then you are asked whether you wish to save the relevant parameters or file before the program is closed.

Shortcut Key : None

Window Close button :  or 

12.2 Edit

Undo – Restores the Item List to the state it was in prior to the immediately preceding Edit action. This includes returning an edited Item and its constituent data values to their state before they were changed. Up to 32 Edit actions can be recorded and undone. If more than 32 Edit actions are performed then only the most recent 32 remain in the record, and can subsequently be reversed.

Shortcut Key : **Ctrl-Z** Toolbar Icon : 

Redo – Re-performs the Edit action which was reversed by an immediately preceding Undo operation. This includes returning an Item and its constituent data values to their edited state. Redo is not active until an Undo action has been performed.

Shortcut Key : **Ctrl-Y** Toolbar Icon : 

Find – Searches the Item List for Items whose Description, Primary Address, or Extended Address match an entered string of characters. The direction of search can be selected, and the search parameters changed, at any time to refine the Find operation.

Shortcut Key : **Ctrl-F** Toolbar Icon : 

Cut – Deletes from the Item List all Items which are currently selected, and places a copy of each of these Items in the Copy Buffer, replacing any previous contents of the Buffer.

Shortcut Key : **Ctrl-X** Toolbar Icon :  (Item Pop-Up menu)

Cut Append - Deletes from the Item List all Items which are currently selected, and adds a copy of each of these Items to the current contents of the Copy Buffer.

Shortcut Key : **Ctrl-U** Toolbar Icon :  (Item Pop-Up menu)

Copy - Copies from the Item List all Items which are currently selected, and places a copy of each of these Items in the Copy Buffer, replacing any previous contents of the Buffer.

Shortcut Key : **Ctrl-C** Toolbar Icon :  (Item Pop-Up menu)

Copy Append - Copies from the Item List all Items which are currently selected, and adds a copy of each of these Items to the current contents of the Copy Buffer.

Shortcut Key : **Ctrl-D** Toolbar Icon :  (Item Pop-Up menu)

Paste - Retrieves all Items currently in the Copy Buffer, and adds a copy of each of these Items to the displayed Item List. The contents of the Copy Buffer remain unchanged, and no Item in the displayed Item List is either changed or overwritten - even if it is identical to one of the added Items (such Items are thus duplicated).

Shortcut Key : **Ctrl-V** Toolbar Icon : 

Empty Buffer - Clears completely all Items currently in the Copy Buffer. This action can be neither reversed nor undone - so any Items which were Cut to the Buffer will be lost permanently.

Shortcut Key : **Ctrl-E** Toolbar Icon : 

Insert Blank Item - Adds a new Blank Item to the displayed Item List, ready for its description and parameters to be set. Note that you do not have control over where in the Item List the inserted Item will appear - this depends on the current Sort settings.

Shortcut Key : **Shift-Insert**

Toolbar Icon : 

Delete Item - Deletes from the Item List all Items which are currently selected. The deleted Items are not moved to the Copy Buffer, but the action can be reversed by using the Undo facility.

Shortcut Key : **Delete**

Toolbar Icon :  (Item Pop-Up menu)

Check All - Places tick marks in the checkboxes to the left of the Descriptions of all Items in the displayed Item List. Such Items are then said to be 'checked' (rather than selected). The action can be reversed by using the Undo facility.

Shortcut Key : **Ctrl-K**

Toolbar Icon : None

Check Selected - Places tick marks in the checkboxes to the left of the Descriptions of those Items in the displayed Item List which have been highlighted. Such Items are then said to be 'checked' (as well as selected). The action can be reversed by using the Undo facility.

Shortcut Key : **Ctrl-L**

Toolbar Icon : None

Invert Checked - Reverses the state of the checkboxes to the left of the Descriptions of all Items in the displayed Item List, ie. places a tick mark in each checkbox which is currently empty, and removes the tick mark from any Item which is currently checked. The action can be reversed by using the Undo facility.

Shortcut Key : **Ctrl-J**

Toolbar Icon : None

Note : To remove tick marks from all Items in the Item List, use Check All followed by Invert Checked.

Select All - Selects (ie. highlights) all Items in the displayed Item List.

Shortcut Key : **Ctrl-A**

Toolbar Icon : None

Invert Selection - Reverses the state of selection of all Items in the displayed Item List, ie. highlights each Item which is not currently selected, and removes the highlight from any Item which is currently selected. The action can be reversed by using the Undo facility.

Shortcut Key : **Ctrl-I**

Toolbar Icon : None

Note : To remove selection from all Items in the Item List, use Select All followed by Invert Selection. Alternatively, simply click on any Item - this will remove highlighting from all Items except the Item which has just been clicked.

12.3 View

Toolbar - Hides the A-Track toolbar icons. Click again to show the icons once more. The menu entry shows a tick mark when the toolbar icons are displayed.

Status Bar - Hides the A-Track status bar. Click again to show the status bar once more. The menu entry shows a tick mark when the status bar is displayed.

Show Checked Only - Displays only those Items which are 'checked' ie. have tick marks in the checkboxes to the left of the Descriptions. Click again to display the full Item List again. The menu entry shows a tick mark when only 'checked' Items are displayed.

Note : This action does not remove any Item from the Item List - it simply hides 'unchecked' Items from view, which can be useful when dealing with long Lists.

Large Icons - Displays the Item List using the Large Icon view, ie. each Item is shown by a large icon corresponding to its Type, with a label taken from the Item Description (abbreviated if necessary) and the Item's checked status. The Item List is displayed in as many columns as will fit within the A-Track window.

Small Icons - Displays the Item List using the Small Icon view, ie. each Item is shown by a small icon corresponding to its Type, with a label taken from the Item Description (abbreviated if necessary) and the Item's checked status. The Item List is displayed in as many columns as will fit within the A-Track window.

List - Displays the Item List using the List view, ie. each Item is shown by a small icon corresponding to its Type, with a label taken from the Item Description (abbreviated if necessary) and the Item's checked status. The Item List is displayed with one Item per row.

Details - Displays the Item List using the Details view, ie. the Item List is displayed with one Item per row and with ten columns to show the Item's Description, Type, Status Flags, Primary Address (Consist Address for Consists, Decoder Address for Accessories), Extended Address (blank for Consists, selected Output Address for Accessories), Controller to which the Item is currently allocated (*only used with NCE Power Pro, Version 1.65 Power Cab and Smart Booster, and DCC Twin Systems*), Speed Step precision, current Speed and Direction, Headlight state (*the last two only used with NCE Power Pro, Version 1.65 Power Cab and Smart Booster, and DCC Twin Systems*), and state of Functions 1 to 8 (or Outputs 1 to 8 for Accessories), respectively. The Description field also contains the Item's checked status and a small icon corresponding to its Type.

Note : Either the Item's Primary or Extended Address (Decoder or Output Address for Accessories) will be preceded by a '>' character to indicate which Address will be active when the Item is under individual control on the layout. When the Item Type is Multiple (a member of a Consist) then the Consist Address will be shown in the inactive Address column, instead of either the Primary or the Extended Address, and will be preceded by an '=' character.

Arrange Icons - Displays a secondary menu showing six options -

- **by Description** - Sorts the displayed Items into alphabetic order according to the text of the Item's Description. Clicking on this menu entry again will change the Item sort order from ascending to descending or vice versa.

- **by Type** - Sorts the displayed Items into alphabetic order according to the Item's Type (Loco, Consist, Multiple, or Accessory). Clicking on this menu entry again will change the Item sort order from ascending to descending or vice versa.
- **by Flags** - Sorts the displayed Items into alphabetic order according to the state of the Item's Status Flags (Active, Edited, Not Programmed, and Activated). Clicking on this menu entry again will change the Item sort order from ascending to descending or vice versa.
- **by Primary Address** - Sorts the displayed Items into numeric order according to the value of the Item's Primary (or Consist or Accessory Decoder) Address. Clicking on this menu entry again will change the Item sort order from ascending to descending or vice versa.

Note : The preceding '>' character, to indicate that the Primary Address is active for an Item, or '=' character to indicate membership of a Consist, is taken into account when sorting, so that all Items with an active Primary or Decoder Address, or in a Consist, will be grouped together before sorting into numeric order.

- **by Extended Address** - Sorts the displayed Items into numeric order according to the value of the Item's Extended (or Accessory Output) Address. Clicking on this menu entry again will change the Item sort order from ascending to descending or vice versa.

Note : The preceding '>' character, to indicate that the Extended or Output Address is active for an Item, or '=' character to indicate membership of a Consist, is taken into account when sorting, so that all Items with an active Extended or Output Address, or in a Consist, will be grouped together before sorting into numeric order.

- **by File Order** - Sorts the displayed Items into the order in which they are held within the Item List's stored file. This order corresponds (approximately) to the order in which Items have been added to the Item List. Note that, whenever an Item is changed or modified in any way, it is moved to the end of the Item List.

Items can also be sorted into File Order by clicking on the  toolbar icon.

One (and only one) of the Arrange Icons sub-menu entries will always show a tick mark to indicate the current sort order of the Item List.

Note : In Details view, the Item List can be sorted by any of the above categories (apart from File Order) simply by clicking on the appropriate column header. Clicking on the same column header again will change the Item sort order from ascending to descending or *vice versa*. When clicked, the column header will show a small icon to indicate ascending (▲) or descending (▼) sort order.

Line Up Icons - In the current release of A-Track this only has an effect in Small Icons and Large Icons views where, if the icons are shown in a few columns, this menu option will increase the number of columns to fill the full width of the window. Normally, in Large Icons and Small Icons views, the Item entries automatically realign themselves after any Item has been dragged to a different position within the window.

Consist Status – Cmnd Stn / Item List - Displays a window showing all Consists which are currently defined in either an NCE Command Station Consist table (*only NCE Power Pro, Version 1.65 Power Cab and Smart Booster, and DCC Twin*) or the A-Track Item List, or both, together with a list of the Locomotive addresses assigned to the selected Consist within the Command Station (but not necessarily in the Item List).

Consist Status – Backup File / Item List - Displays a window showing all Consists which are currently defined in either a selected Consist backup file or the A-Track Item List, or both, together with a list of the Locomotive addresses assigned to the selected Consist within the Consist backup file (but not necessarily in the Item List).

Note : Where any Locomotive assigned to a Consist is identified in the Item List, its description is displayed alongside the address. Click on any Consist Address to display the status and assignment details of that Consist. Where appropriate, details of a selected Consist can be copied from the Item List to the NCE Command Station ('activated') or from the Command Station to the Item List ('transferred') - in either case overwriting any previous definition of that Consist held in the destination. Although details of a selected Consist can be copied from a Consist backup file to the Item List ('transferred'), overwriting any previous definition of that Consist held in the Item List, Consists cannot be copied to an attached NCE Power Pro Command Station ('activated' - where the Consist address is programmed into the actual assigned Locomotives on the track) directly from a backup file. The Consist must first be transferred into the A-Track Item List.

AIU Status – Turnout Allocation - Opens a utility which allows you to allocate the direction-sensing connection from any turnout connected to the Output of an Accessory decoder, to a selected input of any attached Auxiliary Input Unit. The allocations can then be saved to an AIU Allocation List stored on your PC. Allocations can be loaded into A-Track from the utility, either directly or after a saved AIU Allocation List has been retrieved from storage.

Refresh Item Allocation & Status - Initiates an immediate rescan and update of the full NCE Handheld Cab allocations and status shown the righthand columns of the Item List when using Details view (*only enabled when connected to an NCE Power Pro, Version 1.65 Power Cab or Smart Booster, or DCC Twin Command Station*).

Shortcut Key : None

Toolbar Icon : 

Note : Although clicking on the toolbar icon (shown above) simply initiates a rescan, clicking on the View menu option itself will display a prompt allowing you to disable or continue the periodic scan of attached NCE Cabs (disabled by default). Note that the status of the locomotives currently under control from each NCE Cab is continuously scanned at 2-second intervals. A full scan is only useful if you wish to check on the allocation of locomotives to the Recall list of each NCE Cab, but should be disabled when you want to adjust parameters relating to the NCE Power Pro Command Station or Cabs, or change Consist or Macro settings, to prevent periodic interruptions. The tick mark next to the option on the View menu will only be shown whenever periodic scans of attached NCE Cabs are enabled. Click again on the option when you wish to stop automatic scans of NCE Cab status.

Note : Your choices of View type and format, and all associated parameters, are saved by A-Track and will be applied each time the program is started.

12.4 Item

Edit CVs / Edit Output Details - Opens an Edit Configuration Variables window for the currently selected Item. If several Items are selected (highlighted) then the Edit CVs window is opened for the last-selected Item (identified in the Item List by an outline box drawn around the appropriate Item). The Edit CVs window allows you to view, modify, and save values for each of that Item's Configuration Variables (or Output Details for Accessory Items) as well as a number of other parameters.

Note : Separate Edit CVs windows can be opened simultaneously on the screen for as many Items as you wish, so that you can easily compare, and transfer, CV values between Items.

Shortcut Key : None

Toolbar Icon :  (Item Pop-Up menu)

Allocate NCE Cab - *Only enabled with NCE Power Pro, Version 1.65 Power Cab or Smart Booster, or DCC Twin Systems* - Opens an Allocate Item to NCE Cab window for the currently selected Loco or Consist Item. If several Items are selected (highlighted) then the Allocate Item window is opened for the last-selected Item (identified in the Item List by an outline box drawn around the appropriate Item). The window allows you to allocate control of the selected Loco or Consist Item to any NCE Handheld Controller (Cab), via the Command Station, and to adjust the Item's position in the selected Cab's Recall list.

Shortcut Key : None

Toolbar Icon : None (Item Pop-Up menu)

Note : If the Item currently selected (highlighted) in the Item List has been allocated to an NCE Handheld Controller, then the Allocate NCE Cab entry on the Item menu changes to Deallocate, and the Operate option is disabled. The identity of the allocated NCE Cab appears in the Controller column of the Item List row corresponding to the Item under control. Not applicable to Accessory Items.

Deallocate - *Only enabled with NCE Power Pro, Version 1.65 Power Cab or Smart Booster, or DCC Twin Systems* - Opens a Deallocate Item from NCE Cab window for the currently selected Loco or Consist Item. If several Items are selected (highlighted) then the Deallocate Item window is opened for the last-selected Item (identified in the Item List by an outline box drawn around the appropriate Item). The window allows you to remove the selected Item from the NCE Handheld Controller (Cab) to which it has been allocated.

Shortcut Key : None

Toolbar Icon : None (Item Pop-Up menu)

Note : Once an Item has been deallocated, and that Item is selected in the Item List, the Deallocate entry on the Item menu changes back to the Allocate NCE Cab option, and the Operate option is enabled. Not applicable to Accessory Items.

Operate - Opens an Operate Item window for the currently selected Item. If several Items are selected (highlighted) then the Operate Item window is opened for the last-selected Item (identified in the Item List by an outline box drawn around the appropriate Item). The window provides a 'soft' controller on the screen, giving you control of the Item's speed, direction, and functions for Locomotive Items, or output states for Accessory Items, using mouse and keyboard.

Shortcut Key : None

Toolbar Icon :  (Item Pop-Up menu)

Note : Up to eight Operate Item windows, corresponding to eight selected Items, can be opened simultaneously on the screen. However, the facility should be used with

caution as it is very easy to lose track (literally) of which Item is under control from a particular Operate Item window when more than two or three are active.

12.5 NCE

System Backup - Saves the NCE Power Pro, Version 1.65 Power Cab or Smart Booster, or DCC Twin Command Station setup parameters to a disk file. A standard Windows Save File Dialog is displayed, allowing you to navigate to the drive and folder where the System Backup file is to be saved. You can edit the displayed default filename by adding specific details to it, enter a completely new filename, or select an existing file to be replaced with the current System Backup details. Click Save to save the System Backup file. If you have chosen to overwrite a previous version of System Backup then you are asked to confirm your choice.

Consist Backup - Saves the complete table of Consists stored in an NCE Power Pro, Version 1.65 Power Cab or Smart Booster, or DCC Twin Command Station to a disk file. A standard Windows Save File Dialog is displayed, allowing you to navigate to the drive and folder where the Consist Backup file is to be saved. You can edit the displayed default filename by adding specific details to it, enter a completely new filename, or select an existing file to be replaced with the current Consist table. Click Save to save the Consist Backup file. If you have chosen to overwrite a previous version of Consist Backup then you are asked to confirm your choice.

Macro Backup - Saves all Macros, or a selected set of Macros, from the table stored in an NCE Power Pro, Version 1.65 Power Cab or Smart Booster, or DCC Twin Command Station to a disk file. In the case of a Power Pro, a window is displayed to allow selection of a set of 64 Macros to be backed up. With all systems, data transfer is followed by a standard Windows Save File Dialog to let you navigate to the drive and folder where the Macro Backup file is to be saved. You can edit the displayed default filename by adding specific details to it, enter a completely new filename, or select an existing file to be replaced with the current set of Macros. Click Save to save the Macro Backup file. If you have chosen to overwrite a previous version of Macro Backup then you are asked to confirm your choice.

Handheld Cab Backup - Saves the setup parameters and list of locomotives or consists allocated to each of a set of NCE Handheld Cabs, as stored in the NCE Power Pro, Version 1.65 Power Cab or Smart Booster, or DCC Twin Command Station, to a disk file. In the case of a Power Pro, a window is displayed to allow selection of the set of Cabs to be backed up. With all systems, data transfer is followed by a standard Windows Save File Dialog to let you navigate to the drive and folder where the Handheld Cab Backup file is to be saved. You can edit the displayed default filename by adding specific details to it, enter a completely new filename, or select an existing file to be replaced with the current Handheld Cab Backup details. Click Save to save the Handheld Cab Backup file. If you have chosen to overwrite a previous version of Handheld Cab Backup then you are asked to confirm your choice.

Power Cab / Smart Booster / DCC Twin Combo Backup - Saves the NCE Version 1.65 Power Cab or Smart Booster, or DCC Twin Command Station setup parameters, combined with the tables of Consists and Macros to a disk file. A standard Windows Save File Dialog is displayed, allowing you to navigate to the drive and folder where the System Combo Backup file is to be saved. You can edit the displayed default filename by adding specific details to it, enter a completely new filename, or select an existing file to be replaced with the current System Combo Backup details. Click Save to save the System Combo Backup file. If you have chosen to overwrite a previous version of System Combo Backup then you are asked to confirm your choice.

System Restore - Opens an existing System Backup file and transfers the contents to the NCE Power Pro, Version 1.65 Power Cab or Smart Booster, or DCC Twin Command Station. A standard Windows Open File Dialog is displayed, allowing you to navigate to the folder where the target System Backup is held. Note that selecting the appropriate file, and clicking Open, will initiate the update of the NCE Command Station setup parameters immediately, without any request for confirmation.

Consist Restore - Opens an existing Consist Backup file and transfers the contents to the NCE Power Pro, Version 1.65 Power Cab or Smart Booster, or DCC Twin Command Station. A standard Windows Open File Dialog is displayed, allowing you to navigate to the folder where the target Consist Backup is held. Note that selecting the appropriate file, and clicking Open, will initiate the update of the Consist table held in the NCE Command Station immediately, without any request for confirmation.

Macro Restore - Opens an existing Macro Backup file and transfers the contents to the NCE Power Pro, Version 1.65 Power Cab or Smart Booster, or DCC Twin Command Station. A standard Windows Open File Dialog is displayed, allowing you to navigate to the folder where the target Macro Backup is held. Note that selecting the appropriate file, and clicking Open, will initiate the update of the parameters held in the NCE Command Station for the set of Macros stored in the Backup file immediately, without any request for confirmation.

Handheld Cab Restore - Opens an existing Handheld Cab Backup file and transfers the contents to the NCE Power Pro, Version 1.65 Power Cab or Smart Booster, or DCC Twin Command Station. A standard Windows Open File Dialog is displayed, allowing you to navigate to the folder where the target Handheld Cab Backup is held. Note that selecting the appropriate file, and clicking Open, will initiate the update of the parameters held in the NCE Command Station for the set of Cabs stored in the Backup file immediately, without any request for confirmation.

Power Cab / Smart Booster / DCC Twin Combo Restore - Opens an existing System Combo Backup file and transfers the contents to the NCE Version 1.65 Power Cab or Smart Booster, or DCC Twin Command Station. A standard Windows Open File Dialog is displayed, allowing you to navigate to the folder where the target System Backup is held. Note that selecting the appropriate file, and clicking Open, will initiate the update of the NCE Command Station setup parameters immediately, without any request for confirmation.

Command Station Setup - Displays a window showing the current values of the NCE Power Pro, Version 1.65 Power Cab or Smart Booster, or DCC Twin Command Station Setup parameters, allowing any of the accessible parameters to be changed and returned to the Command Station. The NCE Power Pro Command Station may also be reset to its power-on state, or have its factory-default parameters restored.

Handheld Cab/AIU Status - Displays a window showing the connection status of all NCE Handheld Cabs, and of any attached Auxiliary Input Units, together with the last known status of, and the list of locomotives allocated to, the currently-selected Cab, or of the turnouts allocated to the currently-selected AIU. Click on the address of any Cab or AIU to update and display its detailed status and allocation list. Any of the parameters of a selected Cab can be changed and returned to the Command Station, and the complete allocation list can be cleared. Note, however, that locomotives or consists cannot be allocated to the current Cab using this window, nor can the turnouts allocated to an AIU be changed (see **Sections 12.4** and **12.9**, dealing with the Item and Pop-Up menus).

12.6 Route

Display Route Macro Table - Opens a blank Route Macro Table with entries for up to 256 Macros. Sets of Route Macros can then either be constructed within the table or loaded from existing Macro Backup files, edited and then saved back to the same or new Macro Backup files. Macros can also be transferred to or from an NCE Power Pro, Version 1.65 Power Cab or Smart Booster, or DCC Twin Command Station, or can be executed directly from A-Track.

New Macro Sets - Clears the existing Route Macro Table if one has been opened previously, or opens a blank Route Macro Table with entries for up to 256 Macros.

12.7 Mimic

Load Mimic Set - Opens an existing Mimic List file and makes a list of the Mimic panels contained in the loaded Mimic Set available when the Display Mimic option on the Mimic menu is selected. The list of Mimics will also appear on the screen next to the mouse cursor as soon as the Mimic panels are loaded. Clicking on the name of any Mimic panel on the list will display that panel and place a tick mark next to its entry in the list. Clicking on the Show All option will display all of the panels in the Mimic Set, place a tick mark next to all entries in the list, and change the option to Hide All.

Save All Mimics - Saves the currently-loaded Mimic Set to a disk file. A standard Windows Save File Dialog is displayed, allowing you to navigate to the drive and folder where the Mimic List file is to be saved. You can edit the displayed default filename by adding specific details to it, enter a completely new filename, or select an existing file to be replaced with the current Mimic Set data. Click Save to save the Mimic List file. If you have chosen to overwrite a previous version of the Mimic List file then you are asked to confirm your choice.

New Mimic - Creates a blank Mimic panel and adds it as the last panel to any currently-loaded Mimic Set. All panels in the Mimic Set are then displayed on the screen. The name which the new panel is given by default (New Layout Mimic #n) will also be added to the end of the Display Mimic list with a tick mark next to its name.

Prepare Find Route - When selected, allows the Find Route operation to be performed by using a single left-click (or tap on a touch-sensitive screen) without the requirement for a Control (Ctrl) key to be held down at the same time. The menu entry shows a tick mark when this Find Route option is enabled.

Shortcut Key : None Toolbar Icon :  (Enabled) or  (Disabled)

Prepare Edit Mimic - When selected, allows the Mimic Edit window to be opened with a single left-click (or tap on a touch-sensitive screen) as well as with a right-click of the mouse. Note that only single Mimic elements can be edited using this option on its own, since selecting a block of elements requires a Shift (⇧) key to be used as well. The menu entry shows a tick mark when this Edit Mimic option is enabled.

Shortcut Key : None Toolbar Icon :  (Enabled) or  (Disabled)

Prepare One Click - When selected, allows you to change the state of any turnout on a Mimic panel with a single left-click instead of a double-click. The menu entry shows a tick mark when the One Click option is enabled..

Shortcut Key : None Toolbar Icon :  (Enabled) or  (Disabled)

Note: Although, when a Mimic Set is loaded, the Prepare Find Route option will always be enabled, the Prepare Edit Mimic option will only be enabled if there is no connection to an NCE Command Station (or the Command Station is switched off). Conversely, the Prepare One Click option is only enabled when there is an active connection to an NCE Command Station. Only one of the 'Prepare' options listed above can be enabled at any given time. Selecting any one of the options will automatically disable the other two.

Refresh All – Updates the displayed state of all turnouts on all Mimic panels with the latest status acquired either from issued Accessory commands or from data input directly through attached Auxiliary Input Units.

Note : Update of turnout status should occur automatically as part of A-Track normal operations, although there may be a delay of a few seconds before all turnouts are updated, particularly with large layouts. Normally, it should not be necessary to use the Refresh All menu option.

Display Mimic – Displays a secondary menu with a list of all Mimics in the loaded Mimic Set. Clicking on the name of any Mimic panel on the list will display that panel and place a tick mark next to its entry in the list. Clicking on the Show All option will display all of the panels in the Mimic Set, place a tick mark next to all entries in the list, and change the option to Hide All.

Arrange Mimic Set - Displays a secondary menu showing two options –

- **Cascade** – Displays all Mimic panels in the loaded Mimic Set as a series of overlapping, cascaded windows, originating in the top left corner of the screen. This allows all Mimic panels to be accessed from the screen, although the details of only the Mimic in the foremost window will be fully visible.
- **Tile** - Displays all Mimic panels in the loaded Mimic Set separately, centred on the screen. With screen sizes less than 1536 x 1024 pixels, only a single Mimic panel will be visible at any one time whereas, with wider screens, up to four (or even six) Mimic panels can be displayed at once. Use the 'D' (Down) and 'U' (Up) keys to display any Mimic panels in the Mimic Set which are not shown currently on the screen in place of those panels which are being displayed.

Reorder Mimic Set - Opens a utility which allows you to change the order in which the Mimic panels of a loaded Mimic Set are stored and displayed on screen. The reordered Mimic Set must be saved before A-Track is closed in order to preserve the changes.

12.8 Help

Help Topics - Displays a comprehensive set of Help pages containing all of the information contained in this Reference Manual. The standard Windows HTML Help format is employed, with all Help pages accessible from a Contents list. Although an Index facility is not available, there is a full Search capability which can be employed to locate all pages containing a particular word or phrase.

Note : Help pages are context-sensitive, so that, when you press the F1 shortcut key at any point when using A-Track, the Help page most appropriate to that part of the program which is currently active will be displayed.

Shortcut Key : **F1**

Toolbar Icon : 

Start-Up Tutorial - Displays the first page of the 'Welcome to A-Track – Your DCC Buddy' demonstration and tutorial, ready to take you through the basic features of the program's operation.

Note : A tick next to this menu entry indicates that the 'Welcome to A-Track' tutorial will be displayed whenever A-Track is started. If you do not wish this to occur, first click this entry to display the 'Welcome to A-Track' help page, then tick the 'Do not display at start-up' checkbox located below the tutorial text before closing the window.

Register / Activate – Opens a window which displays information relating to the version of A-Track which is running, the Serial Number generated when you installed A-Track, details of the version and build of Windows installed on this computer, the type and software version of the NCE System to which you last connected and the current registration / activation status.

If this copy of A-Track has not been registered, the window allows the user to enter his or her name (or the name of a club), and then, provided the computer has an active Internet connection, to access an online facility which will generate an Activation Key (code). The Key should then be copied by the user into the Register / Activate window in order to complete registration. After registration / activation, the window displays the Registered User's name, the Activation Key value, and the date of registration.

Support / Report Problems – Opens a window which displays information relating to the version of A-Track which is running, the Serial Number generated when you installed A-Track, details of the version and build of Windows installed on this computer, and the type and software version of the NCE System to which you last connected. If this copy of A-Track has been registered, the window also shows the Registered User Name and the date of registration. Otherwise, enter your name and then, provided the computer has an active Internet connection, access an online facility which allows you to submit a request for support or to report a problem which you encountered with A-Track.

Check for Updates – Opens a window which displays the currently-installed A-Track version number and the allows you to check, provided the computer has an active Internet connection, whether a more recent version is available for download from the A-Train Systems website. If this is the case, you can then download the setup file for the new version. It is recommended that you uninstall the current version of A-Track before running the setup file to install the updated version. All of your settings and personalisation for A-Track will be preserved and applied to the new version, as will any registration information. There are also options to set a check for updates to be run automatically by A-Track at your choice of interval, provided the computer has an active Internet connection at that time.

About A-Track - Opens a window displaying the Version number of the program, a brief description, and copyright and trademark information –

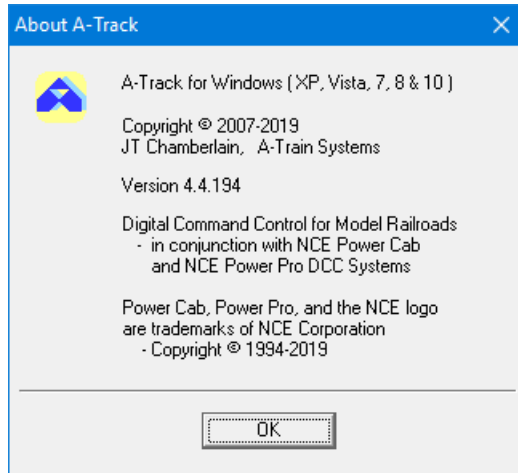

12.9 Pop-Up

When an Item in the Item List is right-clicked, a pop-up menu appears and offers a set of actions selected from the Item and Edit menus. The details are summarised below, but see the entries in the preceding Item and Edit menu descriptions for more complete information.

Edit CVs / Edit Output Details - Opens an Edit Configuration Variables window for the selected Item.

Allocate NCE Cab - Opens an Allocate Item to NCE Cab window for the selected Loco Item to allow you to allocate control of the selected Item to an NCE Handheld Controller (only displayed if connected to an NCE Power Pro, Version 1.65 Power Cab or Smart Booster, or DCC Twin System, and the Item is not currently allocated).

Deallocate - Removes the selected Loco Item from control by the allocated NCE Handheld Controller (only displayed if connected to an NCE Power Pro, Version 1.65 Power Cab or Smart Booster, or DCC Twin System, and the Item is currently allocated).

Operate - Opens an Operate Item window for the selected Item to give you control of the Item's speed, direction, and functions for Locomotive Items, or output states for Accessory Items, from the PC screen (only enabled if the Loco Item is not currently allocated).

Delete Item - Deletes the Item from the Item List (Item is **not** copied to the Copy Buffer).

Cut - Deletes the Item from the Item List, and places a copy of the Item in the Copy Buffer, replacing any previous contents of the Buffer.

Cut Append - Deletes the Item from the Item List, and adds a copy of the Item to the current contents of the Copy Buffer.

Copy - Copies the Item from the Item List, and places a copy of the Item in the Copy Buffer, replacing any previous contents of the Buffer.

Copy Append - Copies the Item from the Item List, and adds a copy of the Item to the current contents of the Copy Buffer.

13 INSTALLATION OF USB-TO-SERIAL INTERFACES

A-Track can be connected to an NCE Power Cab or Smart Booster system by using the NCE USB Interface unit, or can be connected to an NCE Power Pro system either directly from a standard Serial (RS232) port, if your PC is equipped with one, or by using any standard USB-to-Serial interface adapter.

A-Track has been tested with a variety of USB-to-Serial adapters from a number of manufacturers, and will work with devices based on chipsets from Prolific, FTDI, Silicon Labs, Keyspan, and Microchip. Connection of A-Track to an NCE Power Pro Command Station directly from a standard PC Serial Port does not require any additional software to be installed.

Important : If you are planning to use a USB adapter of some kind, then in almost all cases you will need to **install driver software before** you plug the device into your computer and connect to the NCE equipment.

Your USB adapter will either have been supplied with suitable driver software on a CD-ROM disk, or it will come with details of how to download the required driver software from an Internet website (usually that of the manufacturer of the particular chip or chipset incorporated within the USB adapter).

The driver software may or may not come with instructions (or they may either be posted on, or be downloadable from, the same website). While driver installations follow a fairly standard set of steps, the details can vary a lot between manufacturers. It is very important, therefore, that you read any instructions before doing anything, and then follow them exactly in the course of installation – most failed installations result from skipping a vital step, or doing things in the wrong order.

Before starting to install driver software, ensure that the active User has administrative rights (this is the normal status when the operating system is either Windows XP Home or Media Edition, and in both Windows Vista, Windows 7, Windows 8, or Windows 10 Starter or Home Editions, but you may need to log on as an Administrator when using Windows XP Professional Edition, Windows Vista and Windows 7 Business, Professional, or Ultimate Editions, or Windows 8 or Windows 10 Professional or Enterprise Edition).

As an illustration of how to proceed, three examples are given in the following Sections – one for the NCE USB Interface unit, another for a Keyspan USB-to-Serial interface adapter, and finally advice on how to deal with the cheaper type of adapters which employ chipsets made by Prolific. However, be aware that all driver software and their installation programs tend to be updated frequently, so the website links and installation steps to be followed for the version you obtain for your adapter may not be exactly as shown in the following paragraphs.

The one thing that all installations do is to assign a COM Port Number to the adapter. Normally this will be the next available unassigned Number and, when you connect to your NCE system using the adapter, A-Track will automatically determine which COM Port is being used and establish communication without you needing to do anything more.

However, very occasionally, the driver installation software will incorrectly assign a COM Port Number which has already been assigned to another device. In this case you may find that A-Track cannot connect reliably (or at all) to your NCE system. If you do experience problems in this area then, as a first step you should use the Device

Manager application to check that the driver has been properly installed and which COM Port Number has been assigned.

With the adapter plugged into a convenient USB socket, open Control Panel on your computer, find the link or icon labelled **System** and click on it. With Windows Vista, Windows 7, and above this will open a window with a link to Device Manager in the top left corner –

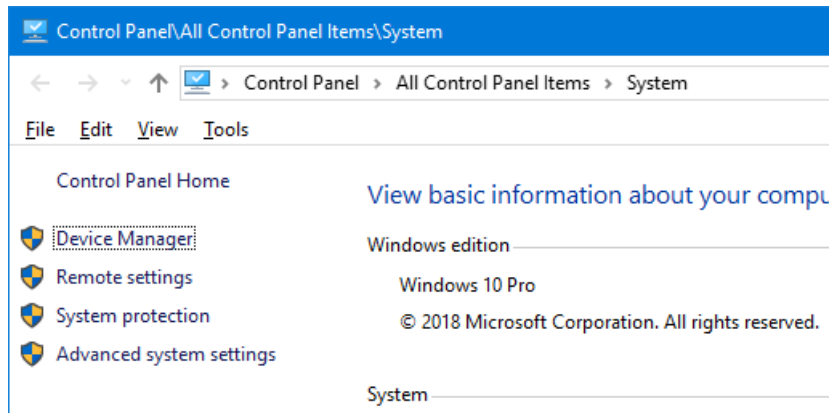

Clicking System in Control Panel when you are using Windows XP opens a rather different window where you need to click on the **Hardware** tab to reveal a button which will give you access to Device Manager –

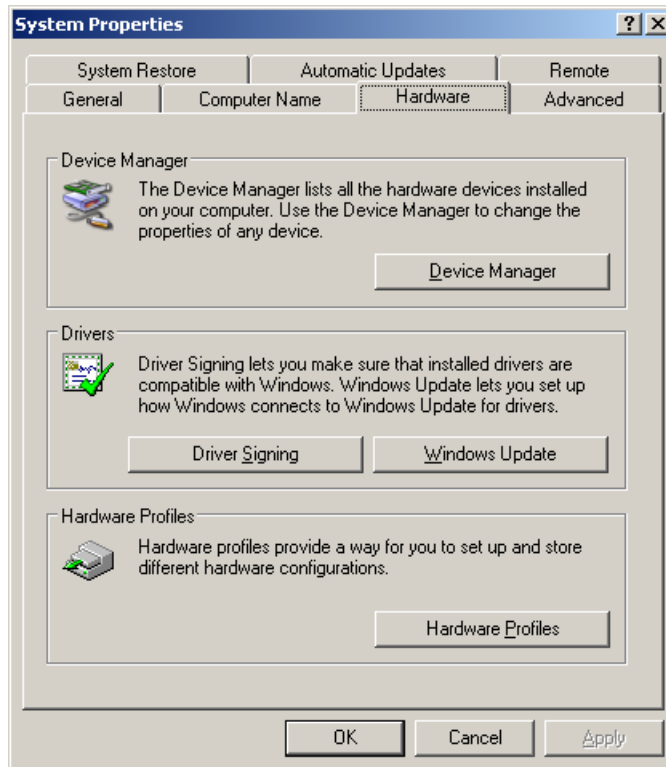

Click on the link or button to open Device Manager, scroll down and expand the Ports (COM & LPT) group, find the entry corresponding to the adapter driver (Silicon Labs in this case, as used for the NCE USB Interface), and right-click on it –

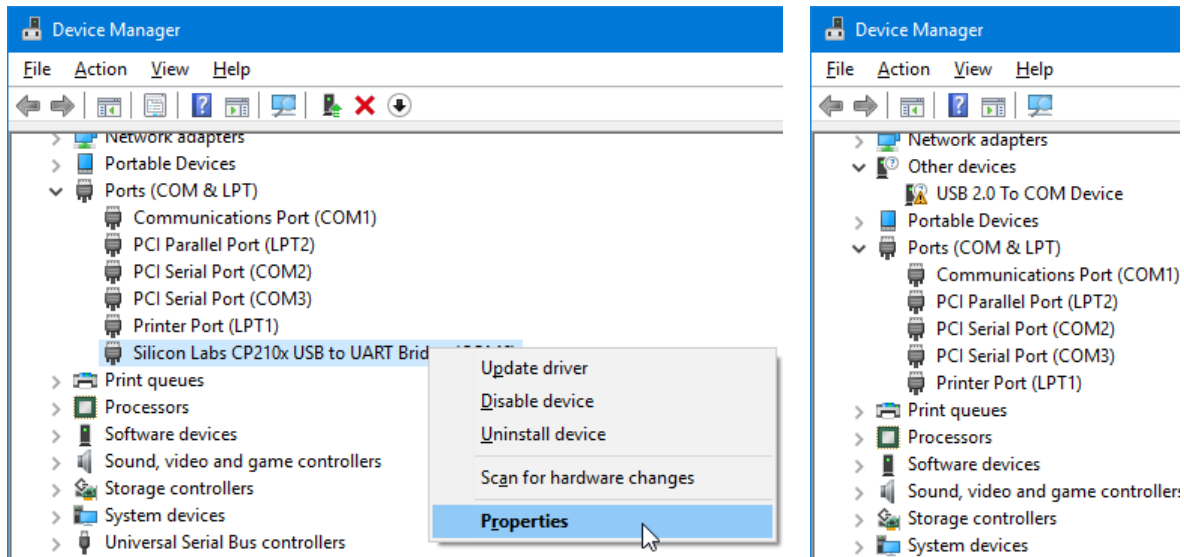

If the adapter driver has installed correctly, you should see a pop-up menu such as that in the lefthand picture above, where you should click on the **Properties** option. Otherwise, if the driver installation has not succeeded, you will see something like the righthand picture where the adapter is shown as 'USB2.0 To COM Device' under 'Other devices' with a small yellow or orange warning triangle. In the latter case you should unplug the adapter and attempt to reinstall the driver, making sure that you follow any instructions carefully and exactly.

Assuming that the driver is correctly installed, clicking on Properties opens a window where you should click on the **Port Settings** tab, followed by the **Advanced** button –

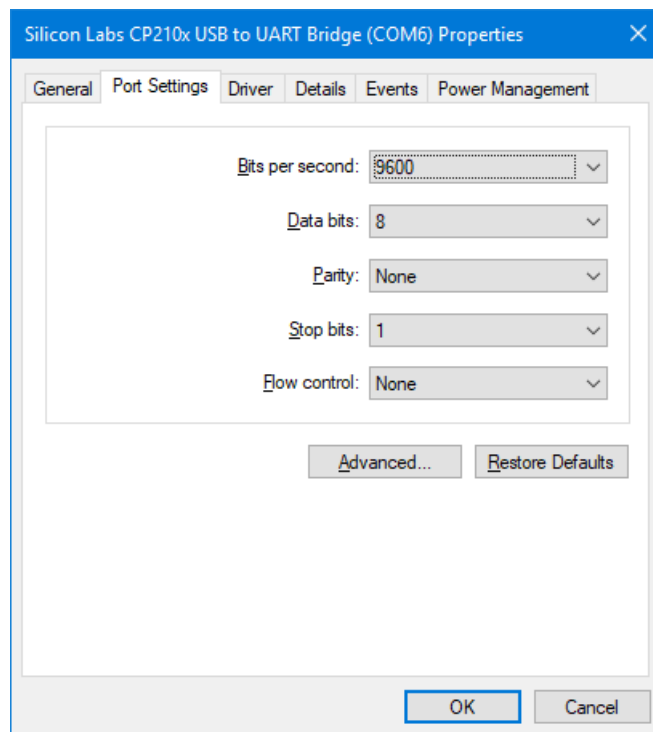

– which opens the Advanced Settings window –

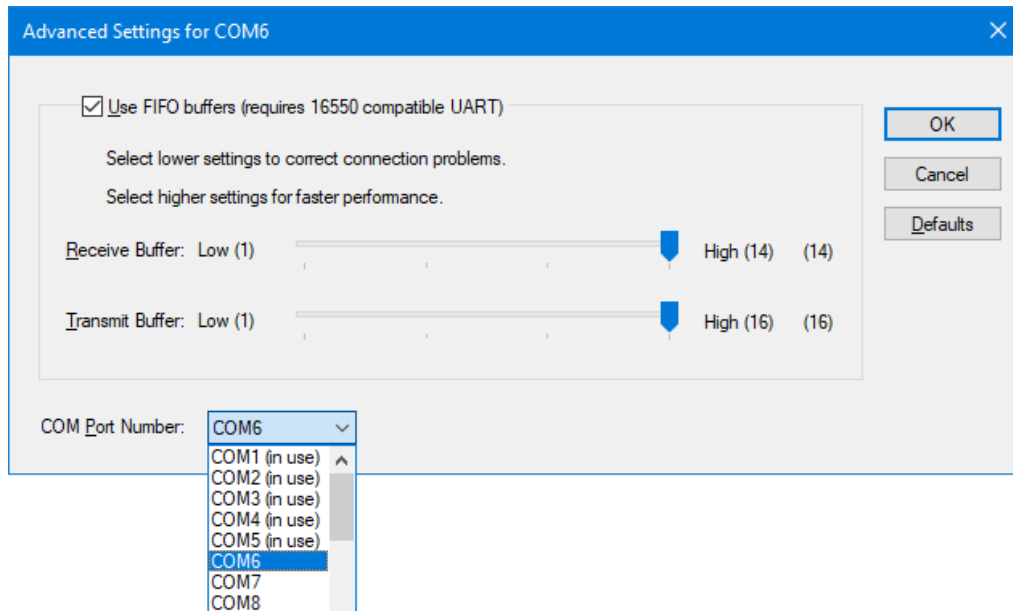

The only setting which should be changed here, if necessary, is the COM Port Number. If you think that the assigned COM Port Number clashes with another device, and is thereby interfering with communications, click on any unused Number in the drop-down list to assign it to your adapter (such as COM7 or COM 8 here), click **OK** twice to close the open windows, and then close Device Manager.

In particular, you should avoid using COM1 through COM4 since, although they may appear to be unused in many cases, they may have been assigned passively to built-in devices on your PC's motherboard so that attempting to use them for your external adapter can result in unexpected behaviour.

13.1 NCE USB Interface Unit

The NCE USB Interface unit is not supplied with any software, but there is a link to the required driver software from the relevant page of the NCE website at –

<https://ncedcc.zendesk.com/hc/en-us/articles/207812203-Windows-USB-Drivers->

Clicking on the link there takes you to a Silicon Labs webpage (see **Section 13.4**) –

<https://www.silabs.com/products/development-tools/software/usb-to-uart-bridge-vcp-drivers>

– where you should download a copy of the ‘CP210x USB to UART Bridge VCP Driver’ for whichever version of Windows is installed in your PC, by clicking this time on the link labelled ‘Download VCP’ in the appropriate Windows section of the page.

Depending on which Internet browser you are using, the driver file will either be downloaded directly to your specified Downloads folder (as with Google Chrome, for example) or you will be prompted to Save or Open (Run) the file (by Internet Explorer, for example). In the latter case, click **Save** to transfer the installation file (such as CP210x_VCP_Windows.zip) to a suitable location on your computer. Do **not** try to Open or Run the driver installation file directly from the Internet.

When download is complete, locate the folder into which you downloaded the installation file. The file is in a compressed or “zipped” form, so the next step is to right-click on the filename, and then click on **Extract All ...** on the pop-up menu (unless you have a third-party utility, such as WinZip, installed on your computer, in which case follow the appropriate procedure).

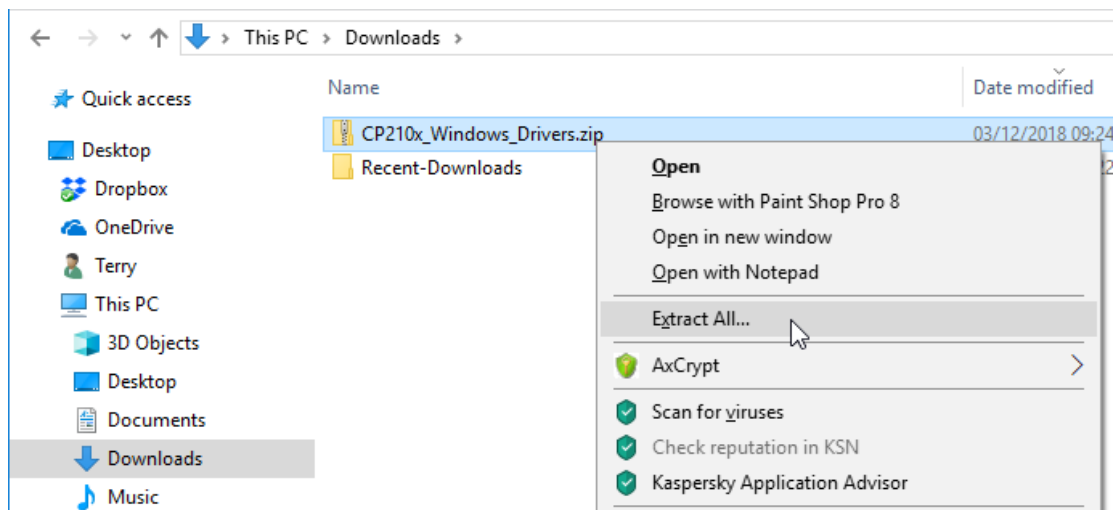

In the window which opens, simply follow the prompts to “unzip” the executable installation files –

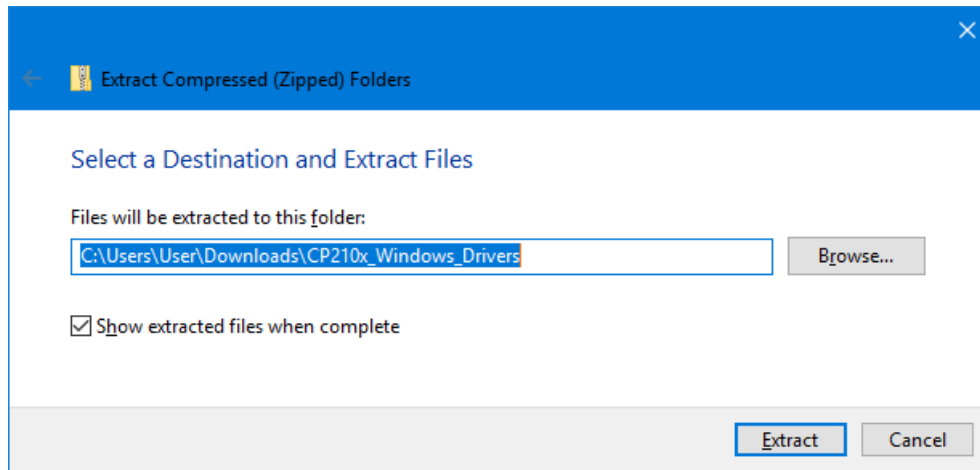

All of the driver files, including **CP210xVCPInstaller_x86.exe** for 32-bit Windows systems, and **CP210xVCPInstaller_x64.exe** for 64-bit Windows systems, will be extracted into a folder which, in this case, is **CP210x_Windows_Drivers**.

This driver is reasonably straightforward to install, and no specific installation instructions are provided. Installation follows the same steps regardless of the version of Windows running on your computer, so the following example will show the process under Windows 10.

The first step is to locate the folder into which you “unzipped” the downloaded file, open the folder, and then **double-click** on the file appropriate to your version of Windows. If you are unsure, click on Control Panel from the Start Menu, and open the System topic which will tell you whether your system is 32-bit or 64-bit.

As soon as the process begins, you should ensure that all other open windows (including Windows Explorer) are closed. A warning notice will generally appear (depending on your security settings), requesting permission to continue –

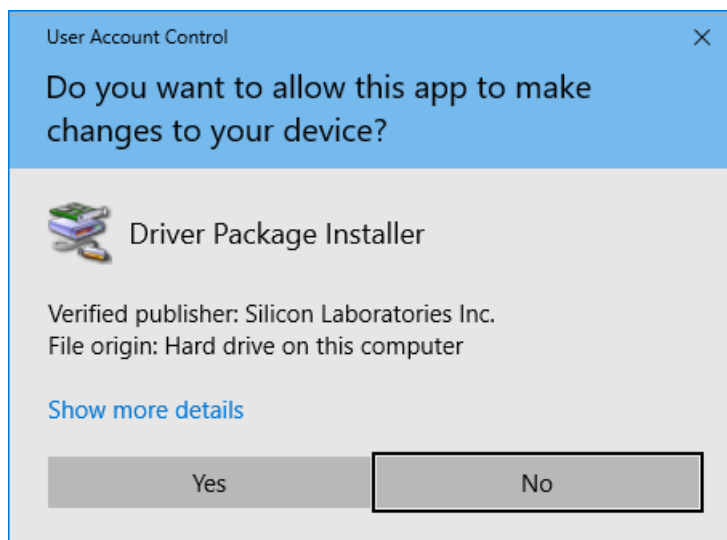

Click **Yes** to start the installation setup. If, for any reason, you have selected the wrong version of setup file, the installer will tell you to use the other one –

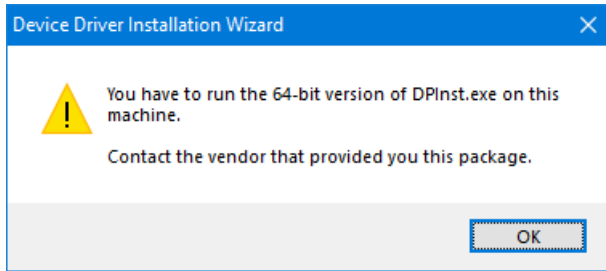

Otherwise, the device driver installation wizard will open –

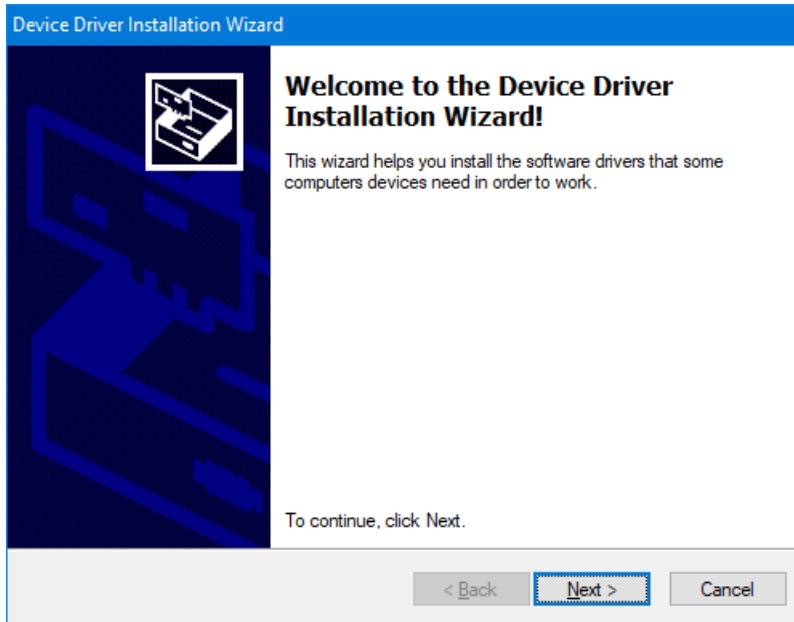

Click **Next** to start the installation of the driver and its support files –

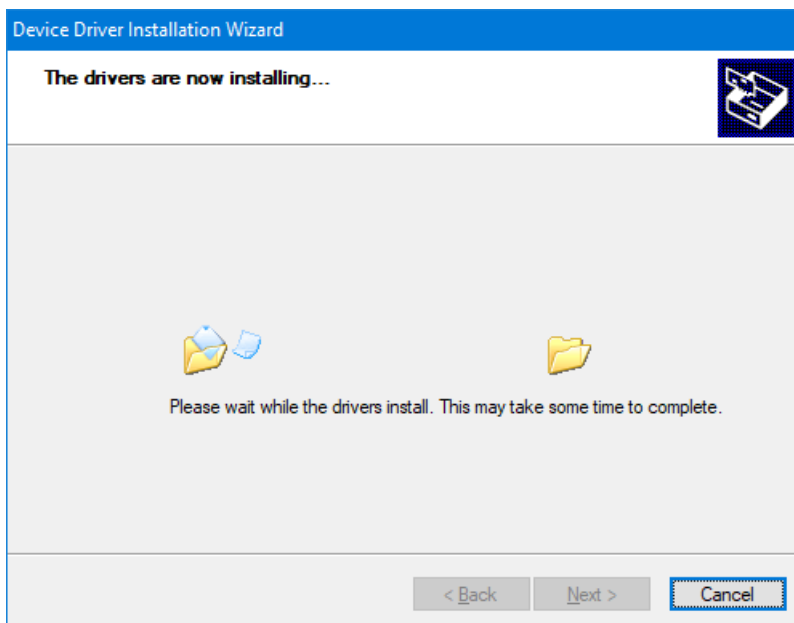

Wait until the installer indicates that file transfer is complete, then click **Finish** to complete the initial software installation and remove the window from the screen –

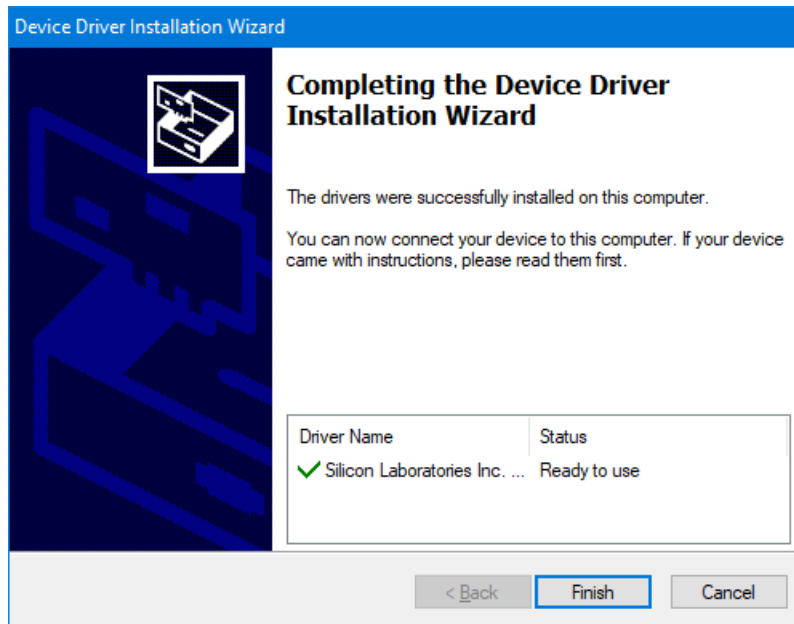

You can now connect the NCE USB Interface unit to any available USB port on your computer, using a standard USB A-B cable, when, depending on your version of Windows, you may see a set of small notices appear in the bottom right corner of the screen. The sequence of notices for Windows XP are shown below –



Wait until the final notice appears, indicating that the connected NCE USB Interface is ready for general use –



The NCE USB Interface unit can now be used to connect A-Track to an NCE Power Cab, Smart Booster, or DCC Twin System. A-Track does not require any detailed knowledge of how the driver software has set up communications for the NCE USB Interface, but will simply search all available communications ports automatically to locate a connection to an NCE System.

Note that if, on some future occasion, you choose to connect the NCE USB Interface to a different USB port on your computer, you may see the 'Found New Hardware' notices appear again as the driver software is linked to the new USB port. After the process completes, A-Track will automatically handle any consequent changes to communications port allocations.

13.2 Keyspan USA-19HS USB-to-Serial Adapter

Depending on where you obtain your Keyspan USA-19HS USB-to-Serial Adapter, it may be supplied with a CD-ROM containing the driver software documentation, or you may be directed to download the driver software from the Internet.

If you have the CD-ROM, then it is simply a matter of inserting the disk into a suitable drive on your computer, waiting for the installation program to run automatically, and then following the on-screen prompts.

Alternatively, you can download the required driver software from the **Support** page on the website of Tripp Lite, the current owners of the Keyspan range of products, at –

<https://www.tripplite.com/support/product/part-number/USA19HS>

Click **Downloads**, followed by **Software, Firmware & Drivers** to reveal the list of available drivers (if it is not already displayed). There are links to two versions of Windows driver software on the page, one for Windows XP and Vista (USA-19HS Driver (Windows 2000, XP, 2003 Server & Vista)) and the other for Windows 7 and above (USA-19HS Driver (Windows 7, 8 and 10, Windows 2008 Server R2)). Make sure that you click on the correct link for your computer's operating system to start the download of the driver software.

Depending on which Internet browser you are using, the driver file will either be downloaded directly to your specified Downloads folder (as with Google Chrome, for example) or you will be prompted to Save or Open (Run) the file (by Internet Explorer, for example). In the latter case, click **Save** to transfer the installation file a suitable location on your computer. Do **not** Open or Run either driver installation file directly from the Internet.

Both drivers are reasonably straightforward to install, and no specific installation instructions are provided. However, you can download a User Manual for the Adapter (which contains a paragraph on installation) by clicking on the link labelled 'Owner's Manual for USA-19HS Windows v3.7S (English)', but this document is not required for normal use of the device.

When download is complete, locate the folder into which you downloaded the installation file. The file is in a compressed or "zipped" form, so the next step is to right-click on the filename, and then click on **Extract All ...** on the pop-up menu (unless you have a third-party utility, such as WinZip, installed on your computer, in which case follow the appropriate procedure). In the window which opens, simply click on **Extract** which will "unzip" the executable installation file into the same folder (either **Windows (2000, XP, 2003 Server, Vista)_v3.7S.exe** or **Windows 2008 Server R2, 7, 8, 8.1 and 10_v4.exe**).

Installation follows the same steps regardless of the version of Windows running on your computer, so the following example will show the process under Windows 10.

Double-click on the unzipped file to start installing the driver. As soon as the process begins, you should ensure that all other open windows (including Windows Explorer) are closed. The normal Windows 10 warning notices will appear (depending on your security settings), requesting permission to run the installation file – click **Yes** to continue and allow the installer to begin –

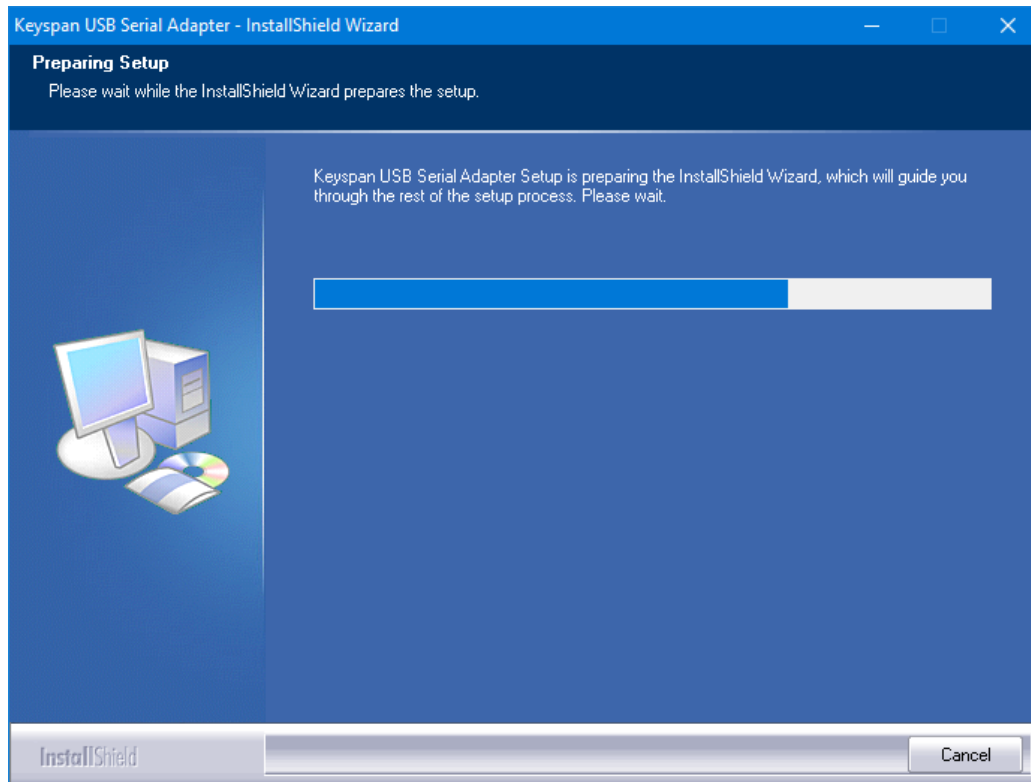

Once initial setup is complete, there is a warning to close all other windows if you have not already done so. Click **Next** to continue, and then click **Yes** to agree to the terms of the software licence –

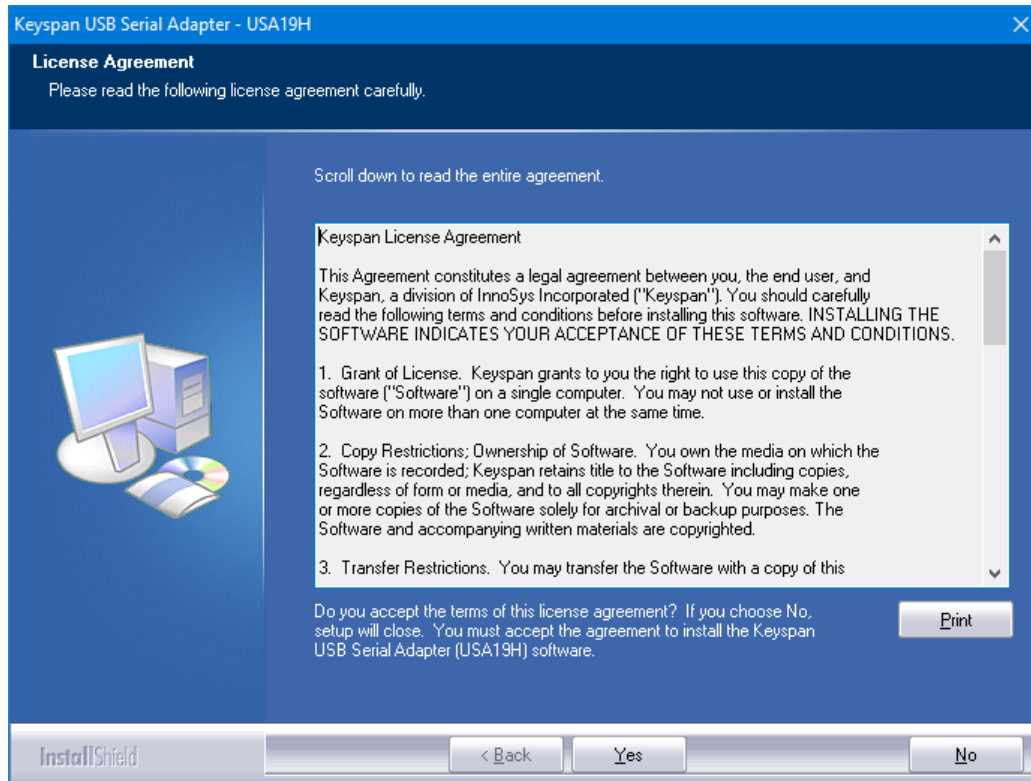

Following this, click **Next** to accept the selected destination folder, after which the installation of the driver files will proceed. You are strongly recommended **not** to change the destination folder since you may prevent Windows finding and running the correct driver when the Keyspan USB-to-Serial Adapter is eventually connected to your computer –

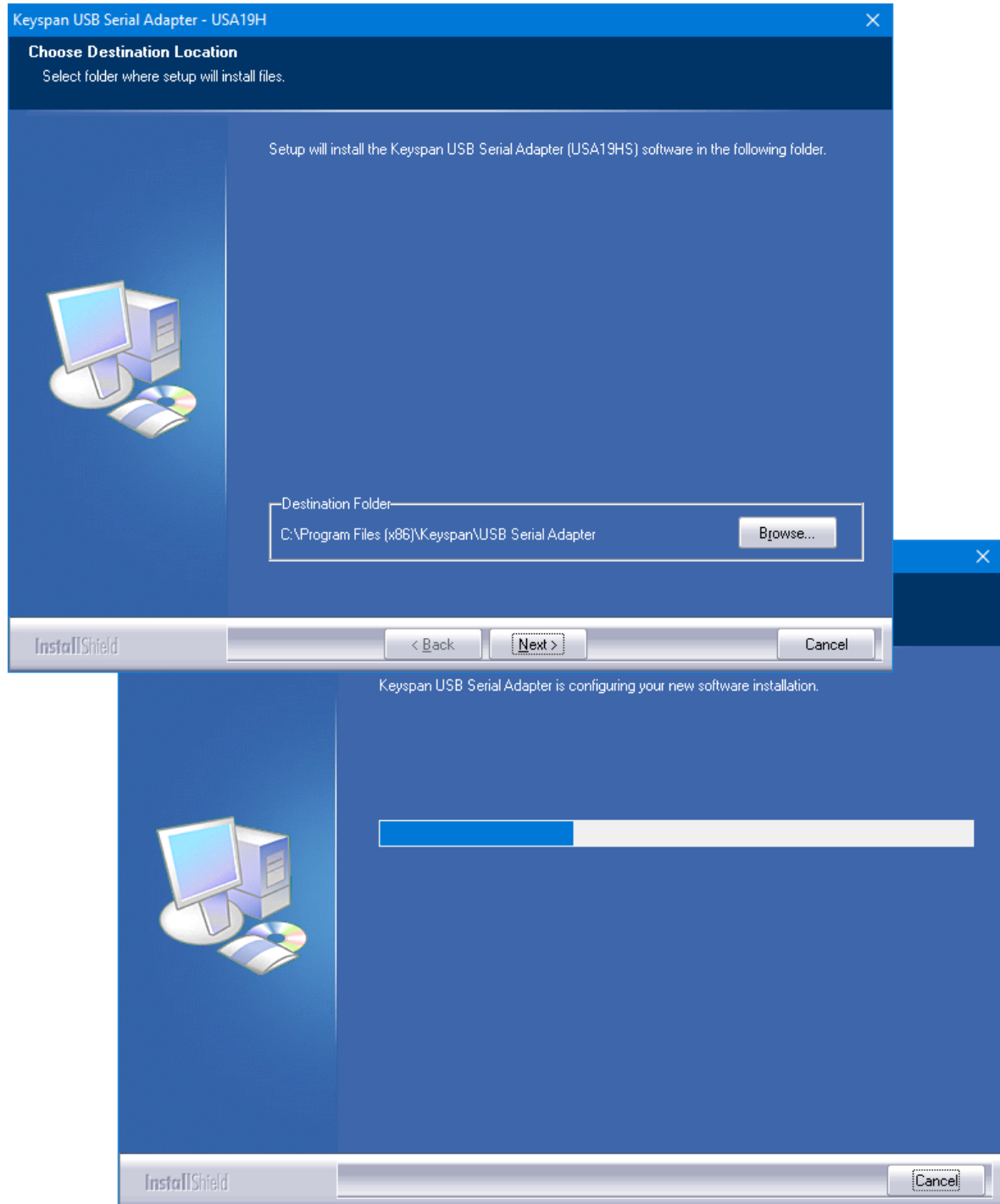

When installation is complete, you will be offered the opportunity to register your copy of the driver.

Registration is unnecessary for proper operation of the driver and adapter, so it is your own choice whether to agree or not. If you choose to click **Cancel**, then you will be given a further set of options, and again you can follow your own preferences –

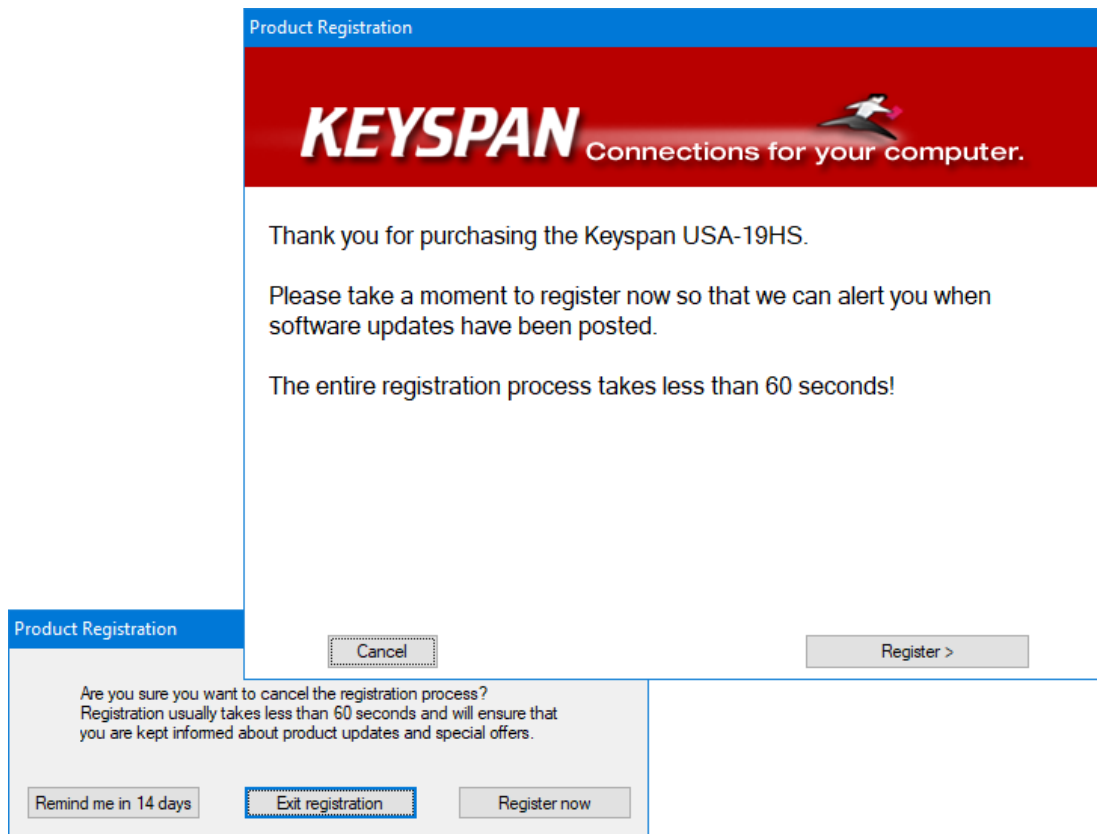

Once registration is accepted or disposed of, there is a final window displayed where you simply click **Finish** to complete the driver software installation –

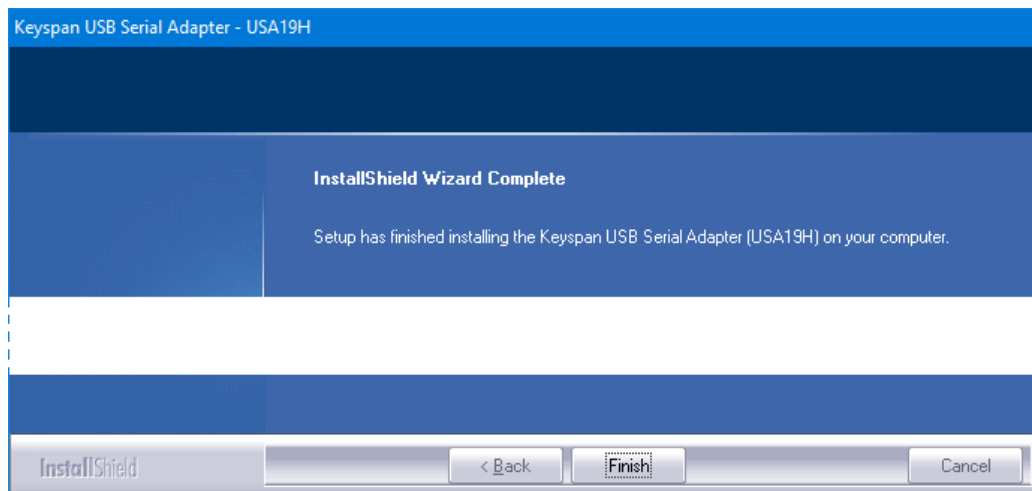

You can now connect the Keyspan USB-to-Serial Adapter to any available USB port on your computer, using a standard USB A-B cable, when you should see a small notice appear in the bottom right corner of the screen, as in this Windows 7 installation –

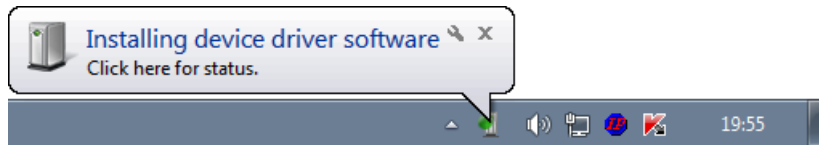

With Windows 7 you have the choice of simply doing nothing, and waiting for final driver installation to complete in its own time, or you can speed the process up a little by clicking on the notice to show the current installation status –

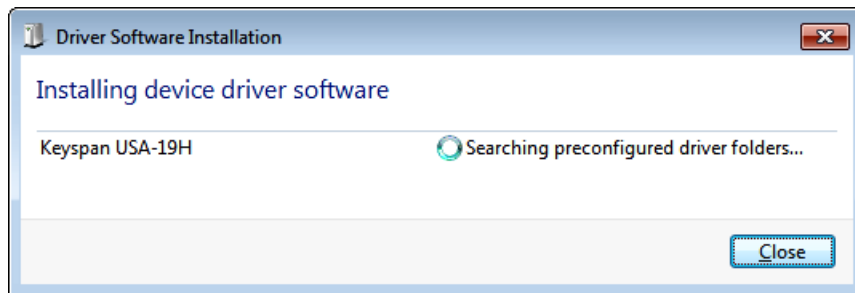

After a short time, you should see a message indicating that Windows Update is being accessed –

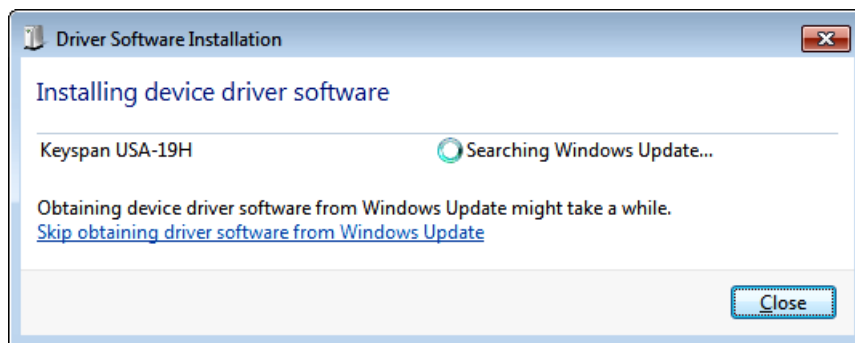

If you have downloaded the latest version of the Keyspan driver software, then this step is unnecessary, so click the link to '**Skip obtaining driver . . .**', then confirm this in the window which appears, by clicking **Yes** –

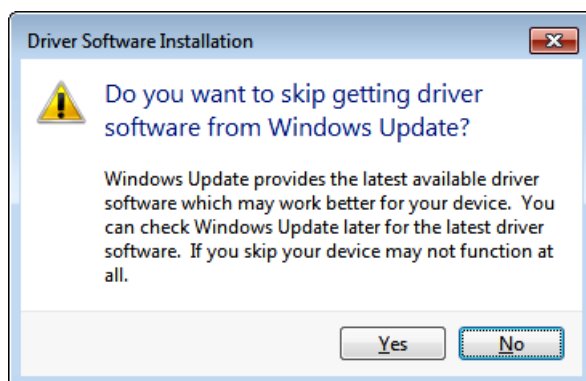

Wait patiently while Windows returns to searching the preconfigured driver folders, and completes the installation of both parts of the driver software –

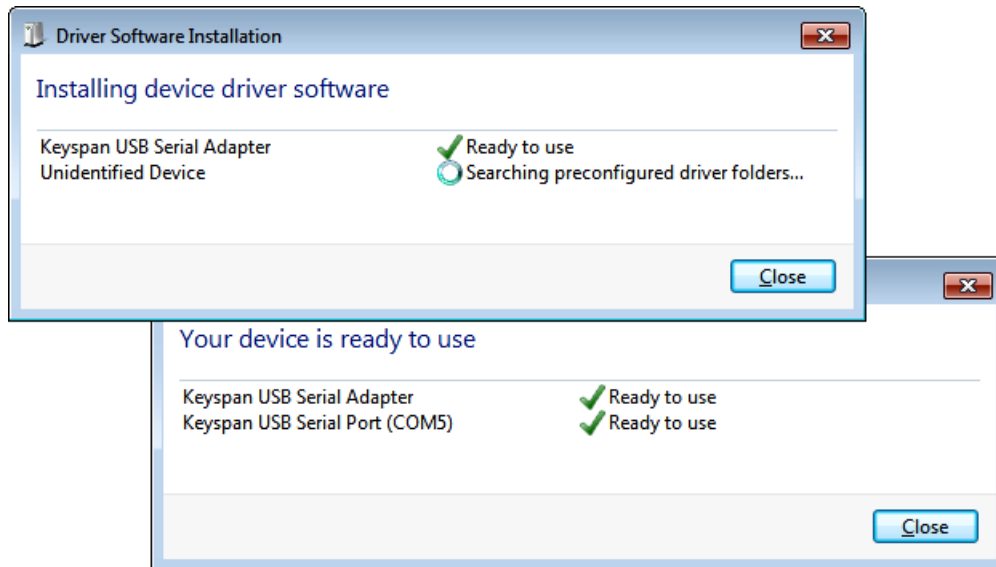

Click **Close** to finish the installation and remove all windows from the screen.

You can now use the Keyspan USB-to-Serial Adapter to connect A-Track to the RS232 Serial Computer Interface (Serial Port) of an NCE Power Pro Command Station. A-Track does not require any detailed knowledge of how the driver software has set up communications for the Keyspan USB-to-Serial Adapter, but will simply search all available communications ports for a connection to an NCE System.

Note that if, on some future occasion, you choose to connect the Keyspan USB-to-Serial Adapter to a different USB port on your computer, you may see the 'Installing device driver software' notice appear again as the driver software is linked to the new USB port. After the process completes, A-Track will automatically handle any consequent changes to communications port allocations.

13.3 USB-to-Serial Adapters using Prolific Chipsets

Many of the cheaper USB-to-Serial adapters on the market are based around chipsets manufactured by Prolific, and users often encounter problems when attempting to install and use such adapters.

When this happens to users who are taking their first steps into the software world, in order to get their PC connected to their railroad control equipment, they tend to pin the blame on the adapter, although this is not always justified.

In most cases the problem is software related - either the driver package is poorly put together (a particular problem with many of the very cheap adapters), or the embedded drivers are incomplete, out-of-date, or fail to load from the supplied installation program, or the drivers are not installed **before** plugging in the adapter.

Problems can also arise in the cheapest adapters either from the incorporation of counterfeit chipsets, which will fail to operate even when the latest genuine Prolific driver software is installed, or from poor quality control during manufacture. In this case, the only solution is to scrap the defective hardware and invest in a better-quality adapter.

Assuming that you are having problems, but do have an adapter with a genuine chipset from Prolific, then you should be able to get it operating properly by following the steps outlined below.

Note that no driver installation should be necessary for Windows 7, 8, 8.1, or 10 computers that are connected to the Internet. The operating system will download the correct drivers automatically when the adapter is plugged in. For all Windows XP and Vista systems and for Windows 7, 8, 8.1, or 10 systems that are not connected to the Internet, please obtain an up-to-date copy of the Prolific driver installation package from a reliable source such as -

<http://plugable.com/drivers/prolific/>

Here, the currently-available file, **PL2303_Prolific_DriverInstaller_v1200.zip**, contains both the driver installer and documentation (and is the driver which is loaded automatically by Windows 7 through 10).

Alternatively, if you want to check that this is the most up-to-date version of the driver (or one which will run on older PC systems), you can visit the Prolific download webpage itself at -

<http://www.prolific.com.tw/US/CustomLogin.aspx>

- where you need to log in using 'GUEST' (**not** your e-mail address) as both user name and password, then click the link labelled 'PL2303 USB to Serial Drivers' to access a list of available driver software, including the latest versions for all Windows systems.

However, **before** attempting to run your newly-downloaded, and saved, driver installer (and certainly do **not** attempt to Open or Run any driver installation file directly from the Internet), you need to get rid of any current installation which is not working properly, since this is likely to prevent installation of the correct driver.

Ensure that the active User has administrative rights (this is the normal status when the operating system is either Windows XP Home or Media Edition, and in Windows Vista or Windows 7 Starter or Home Editions, Windows 8 Standard Edition, and Windows 10 Home Edition, but you may need to log on as an Administrator when using Windows XP Professional Edition, or Windows Vista and Windows 7 Business, Professional, or Ultimate Editions, or Windows 8 or Windows 10 Professional or Enterprise Editions).

Also make sure that the USB-to-Serial adapter which is giving trouble is **unplugged** from your computer at this point. Now open **Device Manager**, by going to Control Panel from the Start Menu or Start Screen and double-clicking on System. Alternatively, for all systems except Windows 8, **right-click** on Computer on the Start Menu, then click on Properties. In Windows 8, from the Start Screen or Desktop, **right-click** in the bottom, lefthand corner of the screen and then click on Device Manager on the pop-up menu.

If you have opened System in Windows Vista, 7, 8, or 10 you should then double-click on Device Manager in the top-left corner of the window. In Windows XP you first need to click on the Hardware tab, and then on the Device Manager button. In all cases, a window showing all installed devices should open, where you can **double-click** on **Ports (COM & LPT)** to view the installed serial ports, as shown below for a Windows XP system -

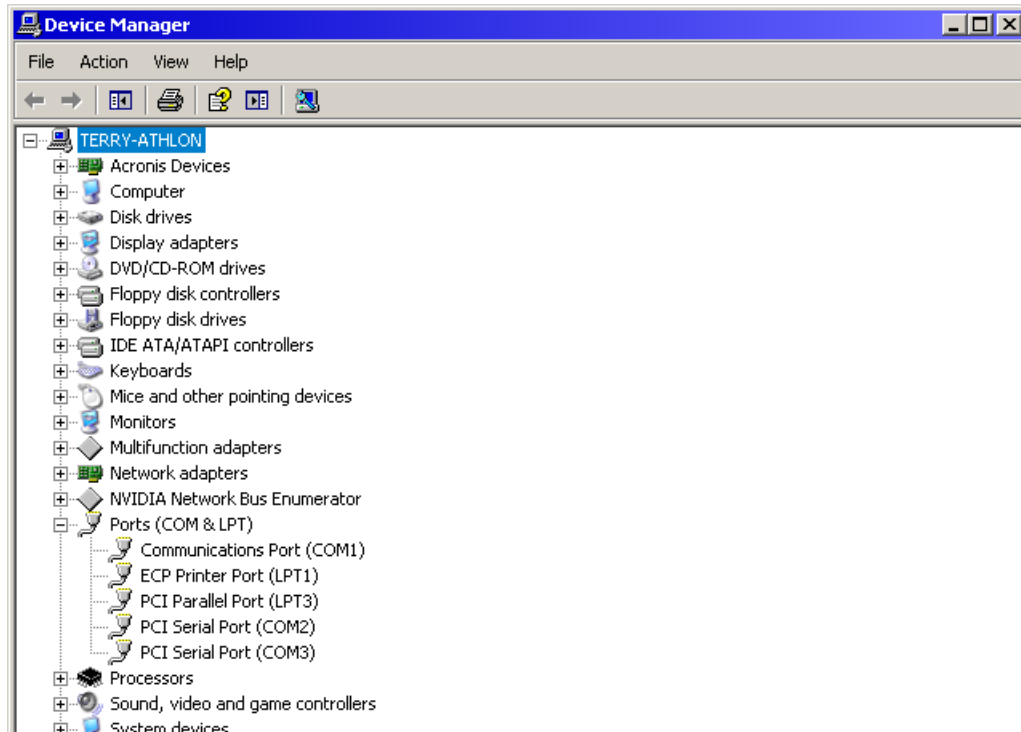

Now **plug** your problem adapter into the USB port on your computer that you normally use. The Device Manager display will update itself automatically, and you should see an additional serial port, with or without a yellow 'fault' flag, as shown below –

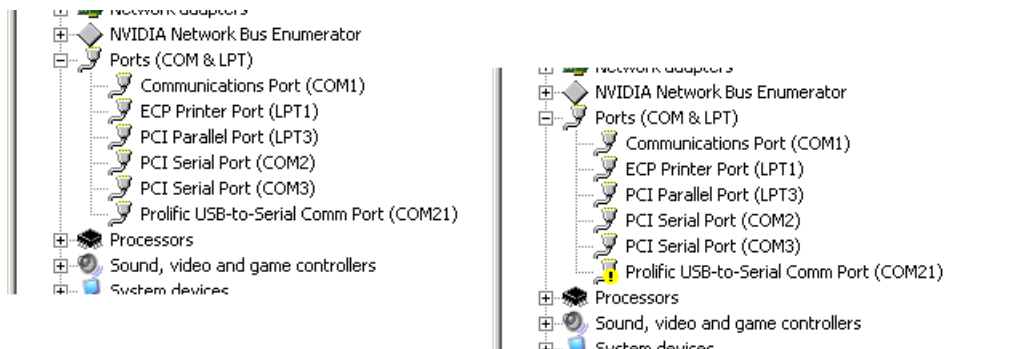

Assuming that the adapter shows up as above (and with 'Prolific' in the name), **right-click** on its entry in the list, and then click on **Uninstall** on the pop-up menu which appears, followed by **OK** on the Confirm Device Removal notice (in Windows 7 and above you should also tick the checkbox with the option to delete the driver software from the machine) –

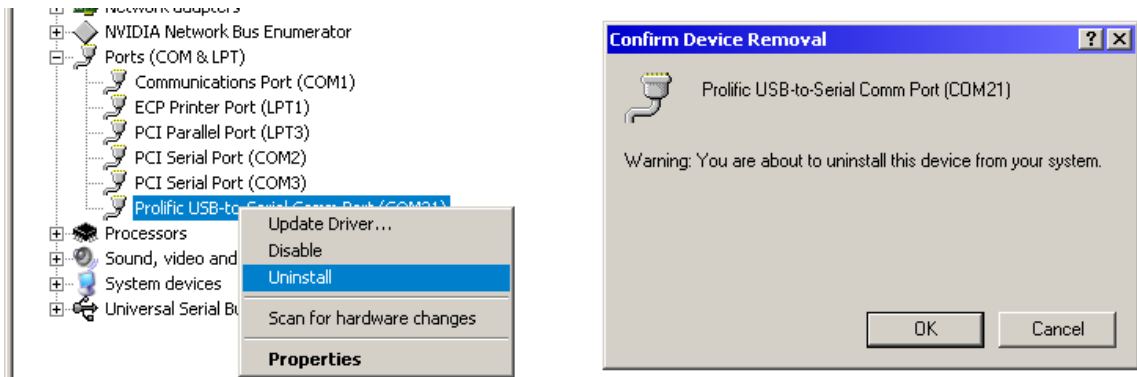

When the entry in the port list disappears, **unplug** the Prolific USB-to-Serial adapter and set it aside.

The next step is to check for, and remove, any installed, but non-operational, driver software by opening Control Panel again and then double-clicking on Programs and Features (or Add or Remove Programs in Windows XP). Wait patiently while the list of installed software is constructed, then scroll down to locate the driver software that you originally installed for your Prolific adapter.

Click on the appropriate list entry, and then click either Change/Remove, as shown for Windows XP below, or Uninstall at the top of the window for the other varieties of Windows –

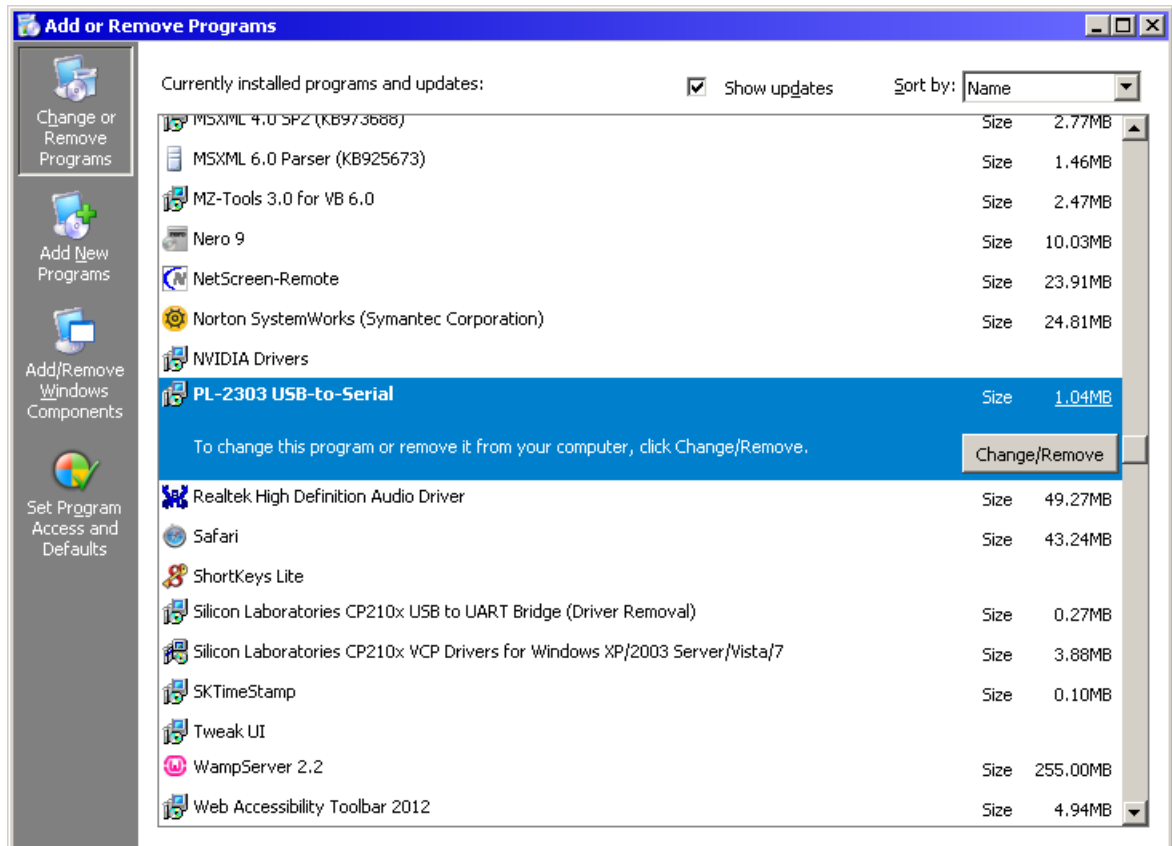

Follow any displayed prompts to complete the uninstallation procedure, including a restart of your computer if necessary.

Now, locate the Prolific driver installation file which you downloaded previously, preferably into its own separate folder. The files contained in the recommended download need to be “unzipped” on your PC before installation, by a right-click on the filename, and then a click on **Extract All ...** on the pop-up menu (unless you have a third-party utility, such as WinZip, installed on your computer, in which case follow the appropriate procedure). In the window which opens, simply click on **Extract** which will “unzip” the executable installation files into the same folder as the original downloaded file.

Prolific include useful documentation (PL2303 Windows Driver Manual v1.20.0.pdf) with the driver software, covering installation instructions for various versions of Windows together with some notes on problems which can arise. However, installation is very straightforward, and you can proceed without needing to refer to the documentation.

Double-click to run the installer file, **PL2303-Prolific_DriverInstaller_v1200.exe**, ensuring that all other open windows are closed. A warning notice, such as that shown below, may appear (depending on your security settings), requesting permission to continue –

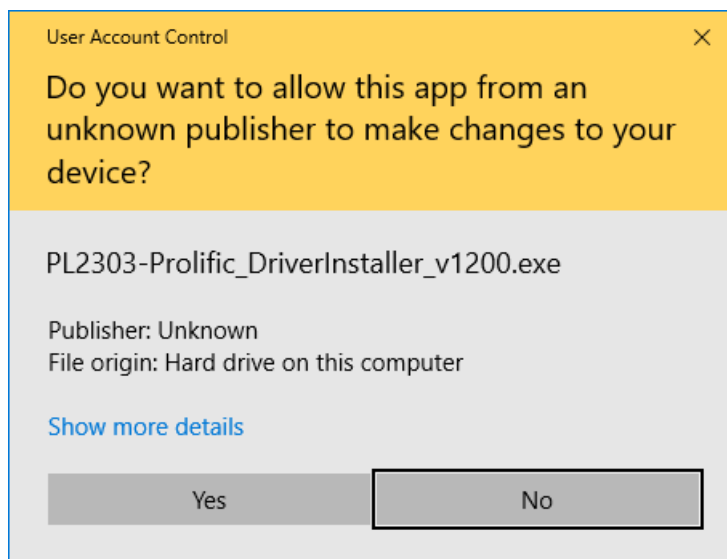

Click **Yes** (or **Run**), then follow the displayed prompts up to **Finish**, to complete the driver installation –

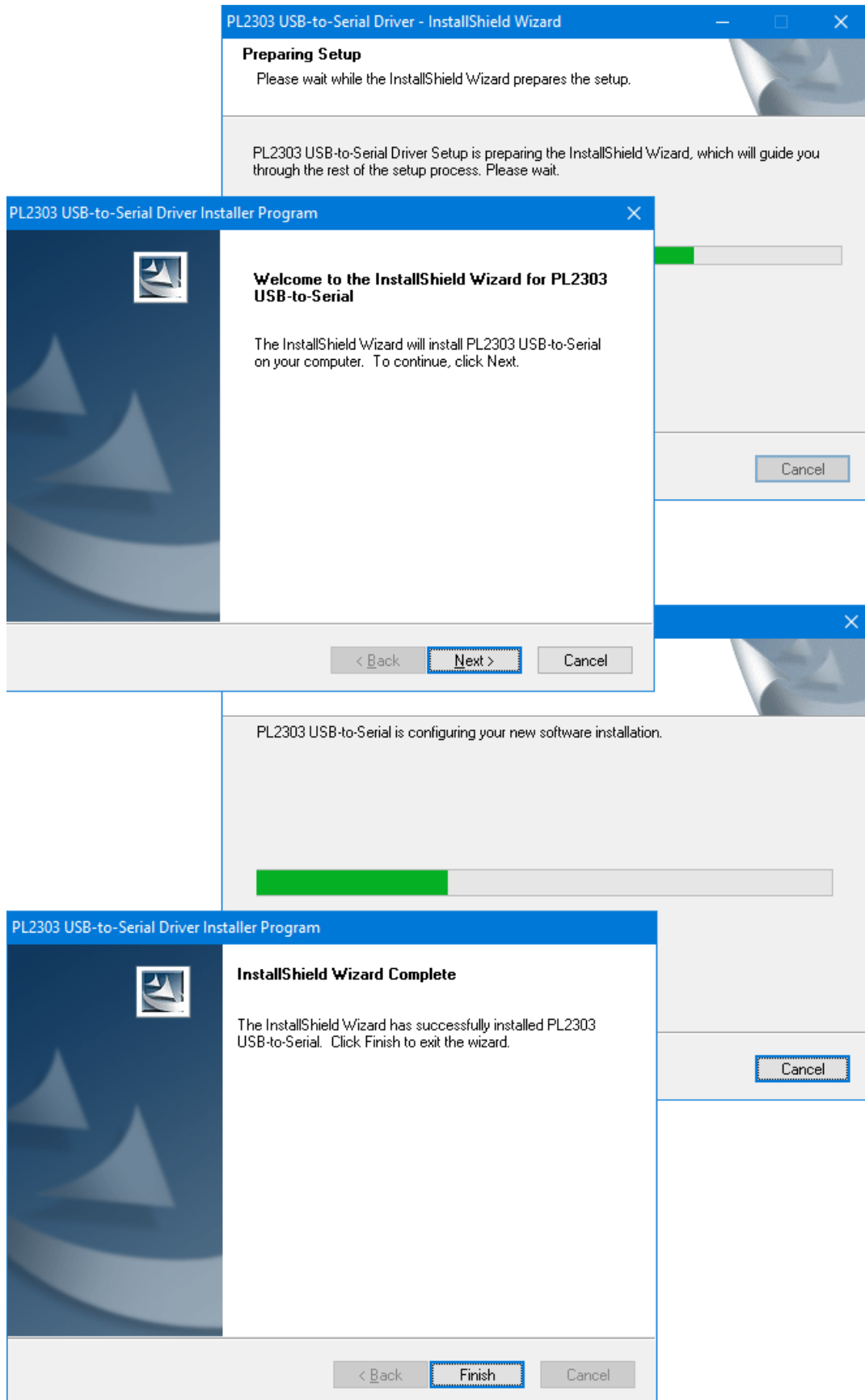

You can now plug the Prolific USB-to-Serial back into whichever USB port on your computer you wish to use, when you may see one or two small notices appear in the bottom right corner of the screen, with a final notice indicating that the connected adapter is ready for general use, as shown in the Windows XP version below –

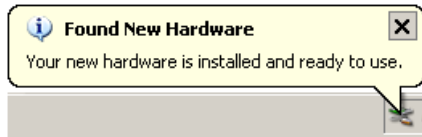

If you wish, you can open Device Manager again and check that the Prolific adapter appears correctly in the list of serial ports. With the serial end of the adapter connected to your NCE Power Pro Command Station, A-Track will automatically identify the correct COM port and establish communication. However, if you are using a JMRI software application, then you will need to take note of the COM port number corresponding to the Prolific adapter (as shown by Device Manager) and select the correct port in the JMRI setup window.

Note that if, on some future occasion, you choose to connect the Prolific USB-to-Serial adapter to a different USB port on your computer, you may see the 'Found New Hardware' notices appear again as the driver software is linked to the new USB port. After the process completes, A-Track will automatically handle any consequent changes to communications port allocations (although you will again have to change any JMRI settings manually).

If you are still having difficulties connecting your Prolific USB-to-Serial adapter to your computer and are seeing messages such as "This Device cannot start (Code 10)", "No driver installed for this device", or "Device driver was not successfully installed" then it may be that you have an older adapter which pre-dates changes Prolific made to their hardware and software to combat the rise of counterfeit devices. Unfortunately, these changes also stopped earlier genuine Prolific devices working as well. A fix for this problem was developed by Family Software of Aston, Pennsylvania and fully described in one of their newsletters –

<http://www.ifamilysoftware.com/news37.html>

This document contains a set of download links to working Prolific drivers for these older devices, covering all versions of Windows. If you make use of this very helpful resource, then you might consider making a small donation to Family Software.

However, Windows 10 is very reluctant to let go of drivers once they have been installed, and even the fix from Family Software can fail on occasion. If Windows 10 insists on re-installing the latest Prolific driver rather than allowing you to use the older (2008) version which works, then you can remove the problem driver manually by using Driver Store Explorer downloaded from –

<https://github.com/lostindark/DriverStoreExplorer/releases/>

Unzip and install the utility, then ensure that you run it as an **administrator**. Wait for the list of installed drivers to be loaded then scroll down to the Ports (COM & LPT) section and remove all Prolific entries (ser2pl.inf). Now run the Family Software utility **without** plugging your Prolific adapter into a USB port. Restart your computer as directed, and then check in Device Manager (or Driver Store Explorer) that the 2008 version of the Prolific driver is being used when you plug in your adapter.

13.4 Links to USB-to-Serial Interface Vendors

The webpage links given in this section represent the best available information, at the time this Reference Manual was written, for those adapter manufacturers whose devices are known to work with A-Track. However, like all information posted on the Internet, the locations of these webpages are subject to change without notice.

If any link no longer appears to function, and you are unable to find the data you require, then please contact A-Train Systems via the Support webpage at <http://www.a-train-systems.co.uk/support.php>, or by e-mail to support@a-train-systems.co.uk, as explained in **Section 11.2**, and I will make every effort to assist.

The same advice applies if you are experiencing any difficulties in using A-Track with a USB-to-Serial adapter which uses a chipset from a manufacturer other than those listed below. Although A-Track ought to work with any adapter which sets up a Virtual Communications Port (**VCP**) in your computer, it is, unfortunately, impossible to guarantee that this will always be the case.

Silicon Labs (for NCE USB Interface)

Driver and documentation available from –

<https://www.silabs.com/products/development-tools/software/usb-to-uart-bridge-vcp-drivers>

Required files are from the section of the page specific to whichever version of Windows is installed in your PC. The download contains drivers for both 32- and 64-bit systems, but needs to be 'unzipped', as explained in **Section 13.1**.

Keyspan

Driver and documentation available from –

<https://www.tripplite.com/support/product/part-number/USA19HS>

Ensure that you select the files which match the correct version of Windows for your computer – one version is for Windows XP and Vista, another for Windows 7, 8 and 10. See **Section 13.2** for a fuller description of the installation process.

FTDI

Driver and documentation available from –

<https://www.ftdichip.com/Drivers/VCP.htm>

Ignore the links in the table of available drivers which are just version numbers. Locate the link labelled '**setup executable**', shown under Comments at the end of the Windows row in the table, then click on the link to download the driver installer file.

Note that there are two versions of the driver available – the first on the page is for Windows 7 through 10 (**CDM21228_Setup.zip**), but you should scroll down to find a second table if you require a version suitable for Windows XP and Vista (**CDM21226_Setup.zip**). Both versions need to be 'unzipped', as explained in **Section 13.1**.

If you require further information, click the link to 'Installation Guides' (near the top of the webpage), which will take you to –

<https://www.ftdichip.com/Support/Documents/InstallGuides.htm>

- from where you can download the document appropriate to your version of Windows.

Note that it is not strictly necessary to follow the rather complicated installation procedure detailed in the FTDI Installation Guides. You can simply run the downloaded and extracted **CDM21228_Setup.exe** (or **CDM21226_Setup.exe**) file **before** plugging the adapter into a USB port. This should open a couple of Command Prompt windows and install the driver, similarly to the processes described in **Sections 13.1, 13.2** and **13.3**. You can then plug the adapter into a PC USB port and wait briefly while the driver is linked to the port.

Prolific (chipset often found in cheaper adapters)

Driver and documentation available from –

<http://plugable.com/drivers/prolific/>

Here, the currently-available file, **PL2303_Prolific_DriverInstaller_v1200.zip**, contains both the driver installer and documentation (and is the driver which is loaded automatically by Windows 7 through 10).

Alternatively, if you want to check that this is the most up-to-date version of the driver (or one which will run on older PC systems), you can visit the Prolific download webpage itself at –

<http://www.prolific.com.tw/US/CustomerLogin.aspx>

- where you need to log in using 'GUEST' (**not** your e-mail address) as both user name and password, then click the link labelled 'PL2303 USB to Serial Drivers' to access a list of available driver software, including the latest versions for all Windows systems.

See **Section 13.3** for a fuller description of the installation process, and for solutions to the various problems which can arise with adapters based on Prolific chipsets.

Microchip (MCP2200)

This device differs from other devices, in that the adapters available are intended primarily for use in a development environment –

<https://www.microchip.com/DevelopmentTools/ProductDetails/MCP2200EV-VCP> and <https://www.microchip.com/DevelopmentTools/ProductDetails/ADM00276>

- although they can easily be put to the alternative use of connecting your PC to an NCE Power Pro. Further information and driver software is available from –

<http://www.microchip.com/wwwproducts/Devices.aspx?dDocName=en546923>

Click on the tab labelled Documents near the foot of the page, then scroll down and click on the **MCP2200/MCP2221 Windows Driver & Installer** link to initiate

download of the file **MCP2221 Windows Driver 2014-10-09.zip** which needs to be “unzipped”, as explained in **Section 13.1**. When you have extracted the contents of the downloaded ‘zip’ file into a folder, locate the subfolder ‘Driver Installation Tool’ which itself has two subfolders, **x64** and **x86**, for 64-bit and 32-bit versions of Windows, respectively. Open the subfolder relevant to your Windows version and run the setup file **McphCdcDriverInstallationTool.exe**. If you pick the wrong version to run you will see a message telling you to use the alternative file.

You may also see a message declaring that the language currently set for your computer is not supported, and which brings proceedings (and installation) to a halt –

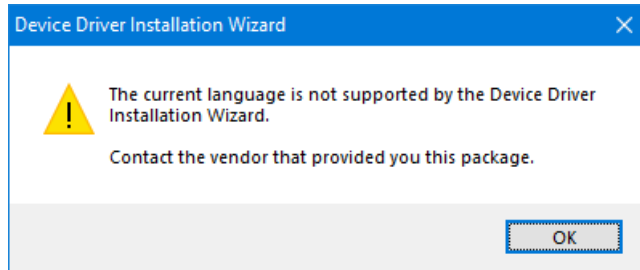

To fix this, locate the file **dpinst.xml** in either the x64 or x86 subfolder and either delete it, or rename it to something like **unused-dpinst.xml**. The only purpose of the file is to display the terms of the Microchip End User License Agreement in your local language. Without the file present, the installation process simply proceeds immediately, without display of the EULA, following similar steps to those described in **Sections 13.1** and **13.3**.

Note : For those users with nothing better to do, you could edit the dpinst.xml file using Notepad or any other text editor, and insert the ID relevant to your installed language into the file, using the codes available from Microsoft at <https://msdn.microsoft.com/en-us/library/cc233965.aspx>, but this is not really worth the effort for an installation you only need to do once.

After installing the driver, plug the adapter into one of the computer’s USB ports, and wait for it to be recognised.

CH340/341 (chipset often found in very cheap adapters)

This chipset was developed by a Chinese company, Jiangsu Yuheng, initially to replace an FTDI chipset used with Arduino microcontroller products (although it does not use FTDI drivers). Trials of USB-to-Serial adapters based on this chipset with A-Track have **not** been satisfactory, with data transfers tending to fail unpredictably and cause A-Track to lock up. Hence, it **cannot be recommended**.

However, if you wish to try such a USB-to-Serial converter, the driver is available from the manufacturer at –

http://www.wch.cn/download/CH341SER_EXE.html

The file CH341SER.EXE is a self-extracting archive which you should run as an Administrator. When the Driver Setup prompt appears, **do not click Install**. Instead, find the extracted folder such as C:\WCH.CN\CH341SER\DRVSETUP64 and then run the installation file DRVSETUP64.exe (for example), again with Administrator privileges to install the driver. You can then plug in the converter and try it with A-Track.

14 USING NCE AUXILIARY INPUT UNITS

14.1 Set-Up and Electrical Connections

As described in **Section 8.4**, NCE Auxiliary Input Units (AIUs) are used to provide feedback from the turnouts on your layout to A-Track via your NCE system. Support for AIUs is provided by the NCE Power Pro and by Version 1.65 Power Cab systems (including Smart Booster and DCC Twin) when operated via a Version 7 USB Interface (but **not** with a Version 6 USB Interface, **nor** with any of the earlier Version 1.28 Power Cab systems operating with either version of USB Interface).

One or more AIUs are added to your NCE system simply by plugging them into the NCE Cab Bus using the supplied cable (6-pin RJ12 connectors), either directly at the Command Station, or via any spare socket on an NCE UTP Panel. The diagram below shows one possible configuration, with two AIUs “daisy-chained” on the Cab Bus, but see the relevant NCE documentation for further information –

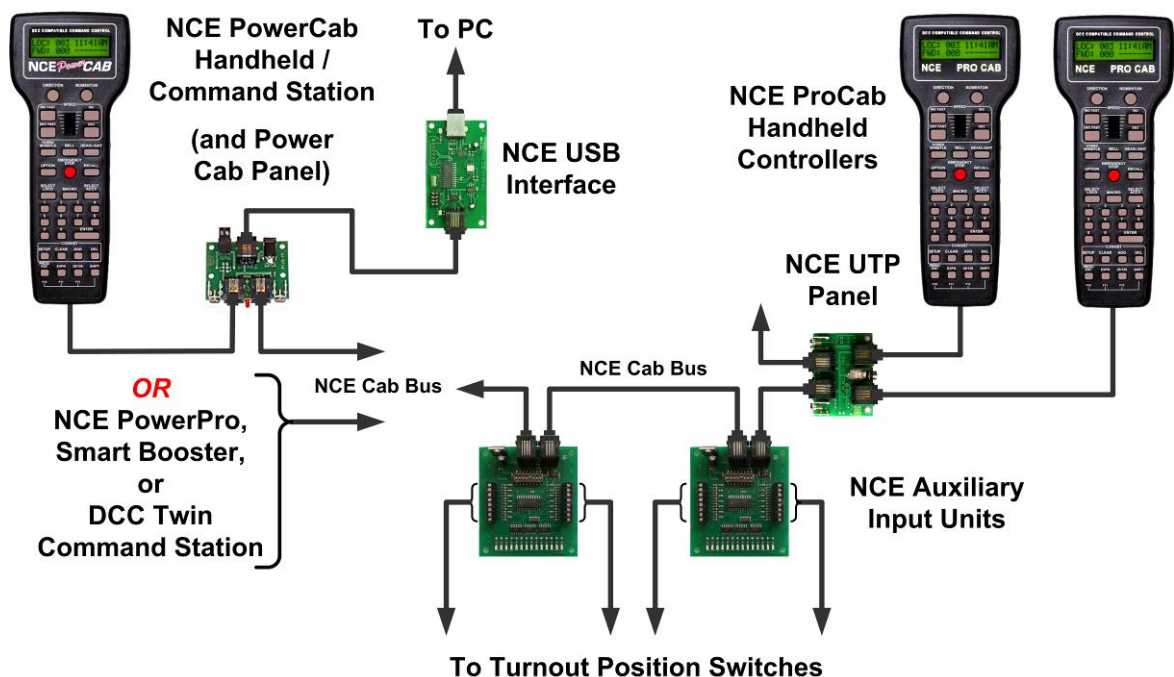

Each turnout to be monitored on the layout needs to be fitted with an electrical switch, mechanically linked directly to either the turnout throw-bar or to the turnout actuating machine (motor). Slow-motion (stall) turnout machines such as Tortoise and Cobalt already incorporate suitable switches for this purpose, but external switches generally have to be added where you are employing solenoid (snap) motors or servos to throw your turnouts.

The first consideration when connecting AIUs to your system is to assign a Cab Address to each AIU, by setting the block of small DIP switches on the AIU board. Although the AIU documentation does explain how the switches are set for a given Cab Address, a couple of examples may help to make this clearer.

Only switches numbered 1 through 6 are used to set the Address – switches 7 and 8 have no effect on the Address regardless of which position they are in. Each switch has

a numerical value as shown in the enlarged picture below. If a switch position is **towards** the two Cab Bus sockets then its value is **added in** to make up the AIU Cab Address, otherwise that switch's contribution to the Address value is **zero** -

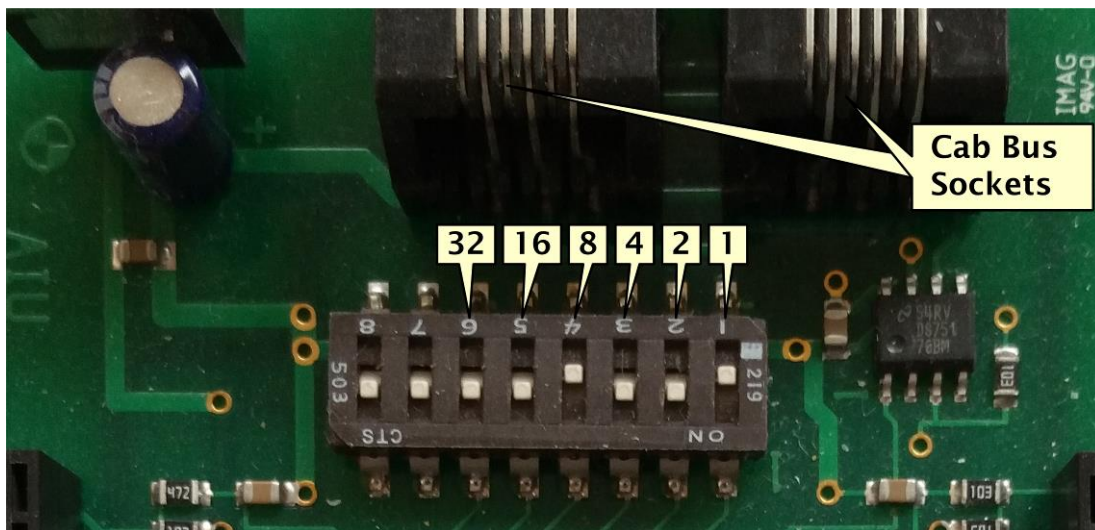

Hence, in the AIU pictured above, with switches 1 and 4 moved towards the Cab Bus sockets, the Cab Address is $(1 + 8)$, ie. **09**.

Alternatively, in the AIU pictured below, with switches 4,5 and 6 moved towards the Cab Bus sockets, the Cab Address is $(8 + 16 + 32)$, ie. **56** -

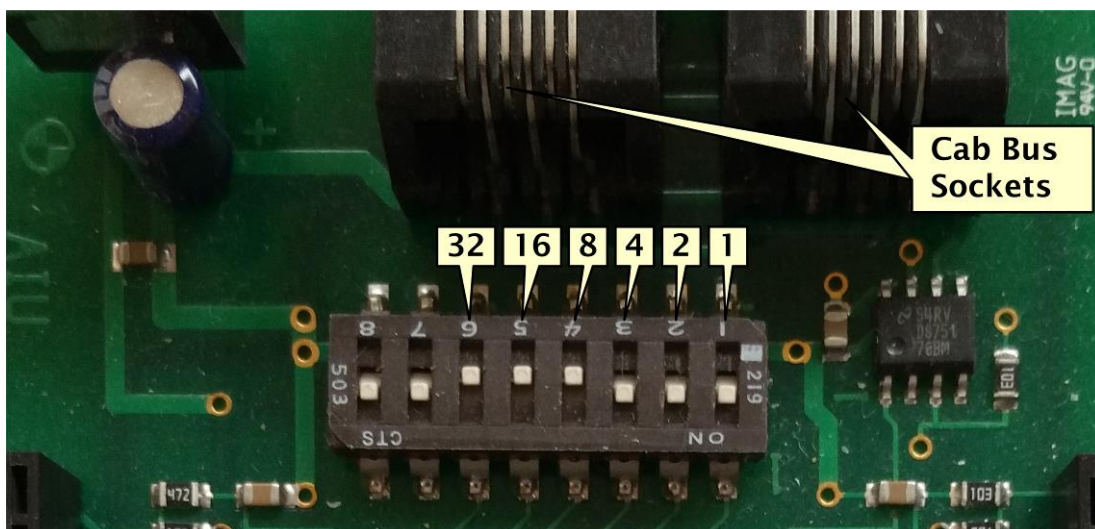

With an NCE Power Pro system, you can use any address in the range 02 to 63, although the recommendation is to restrict AIU addresses to the range of 50 to 63.

A more restricted choice of addresses is available when using a Version 1.65 Power Cab system, which reserves address 08, 09, and 10 for AIUs and like devices. A-Track sets the Cab Address of the USB Interface to 10, leaving addresses 08 and 09 available to AIUs. If you need to add more than two AIUs to a Power Cab system then you can use addresses 03, 04, or 05 at the expense of reducing the number of Handheld Cabs

which can be connected. When using a Smart Booster or DCC Twin system, addresses 02, 06, and 07 are also available for use by either Handheld Cabs or AIUs.

Connections from each AIU to the position switches associated with each turnout, or turnout actuator, on your layout are taken from the pair of 8-screw terminal blocks mounted on either side of the AIU. Each terminal block has one common ground connection and can connect to up to seven turnout switches, as shown for two turnouts in the example diagram below, one (Turnout A) driven by a Tortoise machine and the other (Turnout B) where the actuating motor is fitted with a single microswitch –

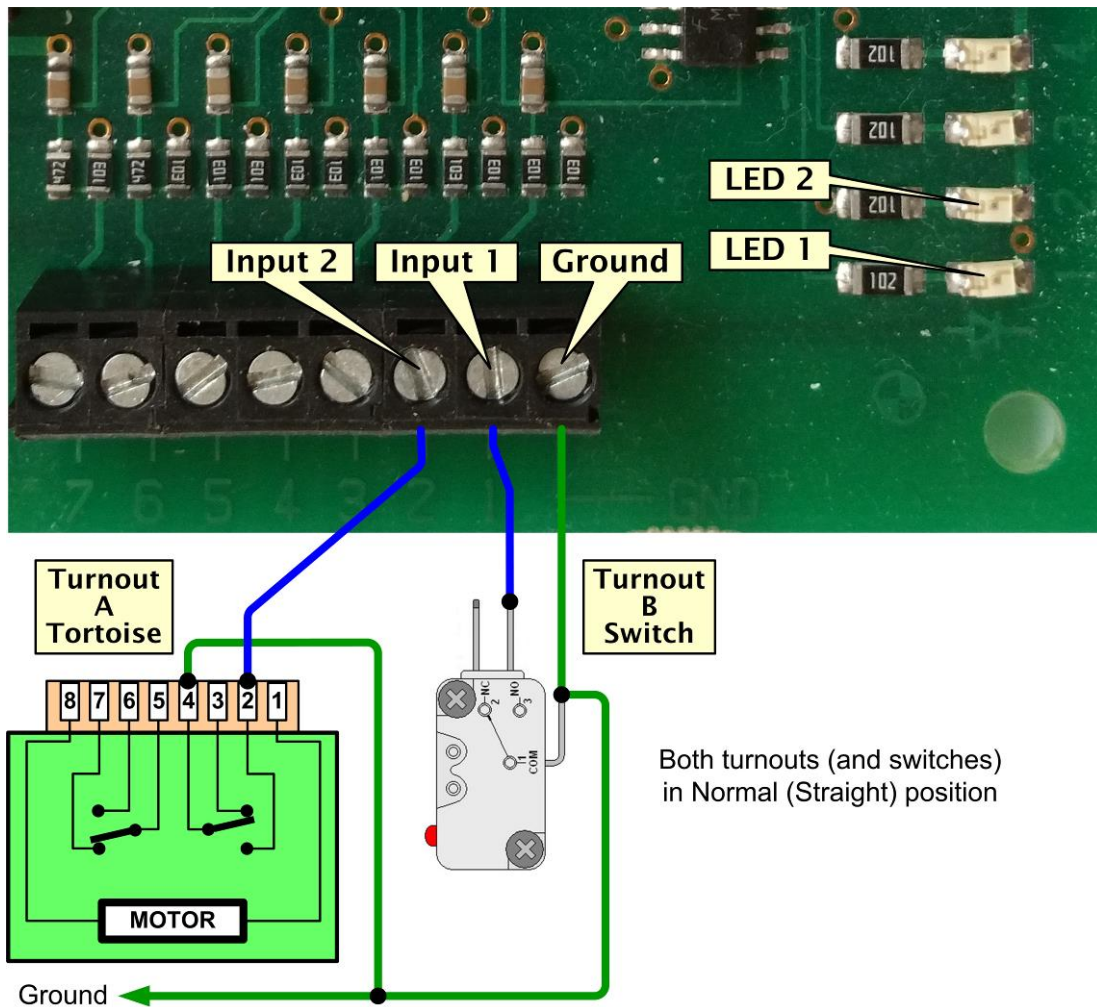

Each switch should be connected such that, when the turnout is set in the Normal (Straight) direction, the switch is open, ie. there is no connection between the common terminal (Tortoise #4 or COM) and the switch terminal connected to the AIU input (the Normally Open, Tortoise #2 or NO, contact in the examples above). In this state, the light-emitting diode (LED) associated with that AIU input will not be lit.

When the direction of the turnout is changed to Route (Diverging), the switch closes, connecting its Tortoise #4 and #2 (or COM and NO) terminals together and, hence, linking the AIU input to Ground. This changes the internal status of the AIU, which can subsequently be accessed by A-Track via a command sent to the NCE Command Station, and illuminates the associated LED.

If you find that, with the turnout in the Normal (Straight) position, when you connect to the switch that the AIU LED illuminates, then swap the connection to the other (Tortoise #3 or NC) switch terminal.

As explained in **Section 8.4**, a set of turnout addresses (including those for Turnouts A and B in the example diagram above) are allocated to the inputs of each AIU so that, when A-Track scans each attached AIU in turn, at 2-second intervals, and detects that an AIU input has been connected to Ground, it can immediately record the change in direction of the relevant allocated turnout. Any displayed Mimic diagram or on-screen controller can then be updated to reflect the new layout configuration.

14.2 Links to Turnouts with Power-Switched Frogs

The majority of layouts are built using turnouts with non-insulated or "live" frogs in order to supply power with as little interruption as possible to locomotives passing through the turnout. This requires that the power to be taken to the frog must be switched from one stock rail to the other, whenever the turnout direction is changed, by using an electrical switch mechanically linked directly to either the turnout throw-bar or to the turnout actuating machine (motor).

The switch to handle power to the turnout frog will need to be separate from any switch which is used to connect to an NCE Auxiliary Input Unit to monitor the turnout position, since the relatively high track voltage employed with DCC (around 14 volts) would destroy the AIU if connected to any of its inputs.

Slow-motion (stall) turnout machines such as Tortoise and Cobalt already incorporate two suitable separate switches for these purposes, so do not present any problem, but solenoid (snap) motors or servos are generally only fitted with a single electrical switch (if any) and it may be quite difficult to install and operate the two switches required.

A possible solution, where only a single switch is available, is to set up the switch to route power from the appropriate track to the turnout frog, and then add some circuitry to convert the voltage at the frog to a form which can be safely applied to an AIU input, and which will then indicate the current direction of the turnout. A module designed by A-Train Systems to perform this function is shown below –



The DCC-AIU Link module allows you to connect up to eight turnout frogs to corresponding AIU inputs without any danger of damaging the AIU by virtue of the pair of optical isolator chips which can be seen in the centre of the module.

The only drawback of this solution is that you will need to build the module (or as many modules as you require) yourself. Although A-Train Systems is happy to provide full details of the module and of the components required, including where you can obtain the printed-circuit board, it is unable to supply either kits of parts or assembled modules.

Building the module requires some familiarity with electronic components, together with the ability to use a fine-tip soldering iron, but does not require any particular electronics expertise. Full details of the components required, suggested sources of supply, and some guidance on construction are given at the end of this Section.

The way in which the DCC-AIU Link module is connected between layout turnouts and an NCE Auxiliary Input Unit is shown in the diagram below, where a pair of turnouts are represented schematically in order to make the wiring between the DCC track power, the switch associated with each turnout, and the turnout frogs as clear as possible. Each turnout (and, hence, its linked switch) is set in the Route (Diverging) direction so the frogs are connected to the correct DCC polarity –

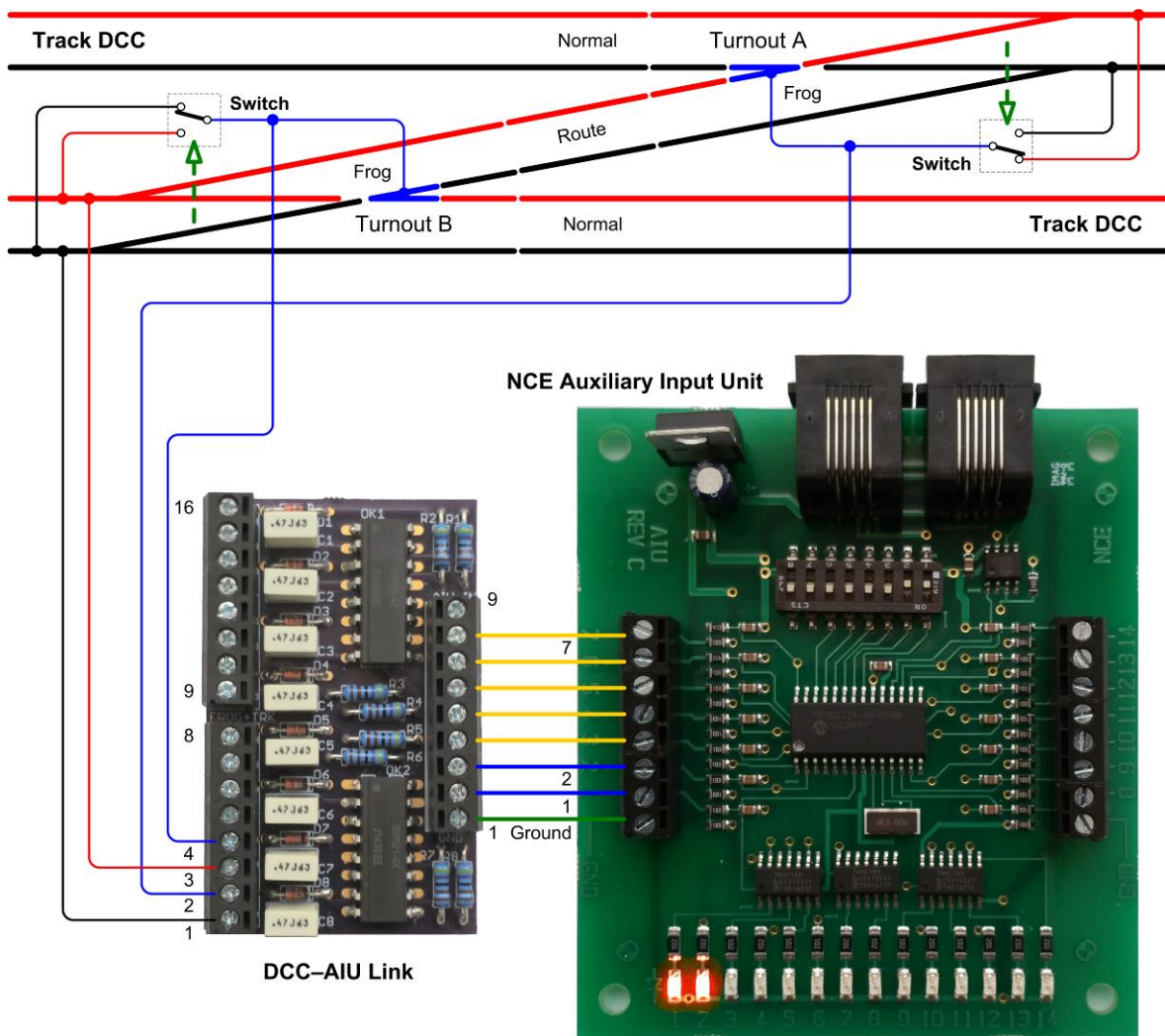

Each pair of terminals in the two 8-way terminal blocks on the left side of the DCC-AIU Link module connects to an individual turnout. A connection to the frog is taken to the

even-numbered terminal (2, 4, 6, etc.) and the corresponding odd-numbered terminal is connected to the stock rail which is **not** connected to the frog when the turnout is set in the Route (Diverging) direction. Hence, for the frog of Turnout A, which is connected to the **red** DCC rail and terminal 2 of the DCC-AIU Link, the **black** DCC rail is connected to terminal 1. For Turnout B, whose frog is connected to the **black** DCC rail and terminal 4, the **red** DCC rail is connected to terminal 3.

Such a connection ensures that the full DCC track voltage is applied to that pair of terminals when the turnout is set in the Route direction.

With the DCC-AIU Link module connected to the NCE AIU as shown above, with terminal 1 of the 9-way terminal block on the right side of the DCC-AIU Link module connected to the GND terminal of the AIU, both terminals 2 and 3 of the 9-way terminal block will be connected to Ground, as will terminals 1 and 2 of the AIU 8-way terminal block. Both LEDs 1 and 2 on the AIU will be illuminated, as shown, and the internal status of the AIU will indicate that both turnouts are set in the Route direction.

In the Normal (Straight) direction the switch linked to the turnout ensures that both terminals of that pair on the DCC-AIU Link module are connected to the same stock rail so that no voltage appears between the two terminals. In this situation the corresponding output terminal to the AIU will not be connected to Ground, the matching LED will not be illuminated, and the internal status of the AIU will indicate that the turnout is set in the Normal direction.

Note that, although the output terminal block connections of the DCC-AIU Link module have been deliberately arranged to align with the AIU input connections, it is not necessary to stick to this connection pattern. Any DCC-AIU Link output can be connected to any input of any AIU. The link between the connected turnouts and any corresponding AIU input is handled by A-Track through the AIU Turnout Allocation tables, as described in **Section 8.4**. The only essential connection is from terminal 1 of the DCC-AIU Link output block to one of the GND terminals of the AIU.

The DCC-AIU Link module connections are summarised in the table below –

Left Terminal Block (Input)		Right Terminal Block (Output)	NCE AIU (Input)
Stock Rail	Frog		
		1	Ground
1	2	2	Any
3	4	3	Any
5	6	4	Any
7	8	5	Any
9	10	6	Any
11	12	7	Any
13	14	8	Any
15	16	9	Any

For anyone who is interested, the schematic for the DCC-AIU Link module is shown on the following page –

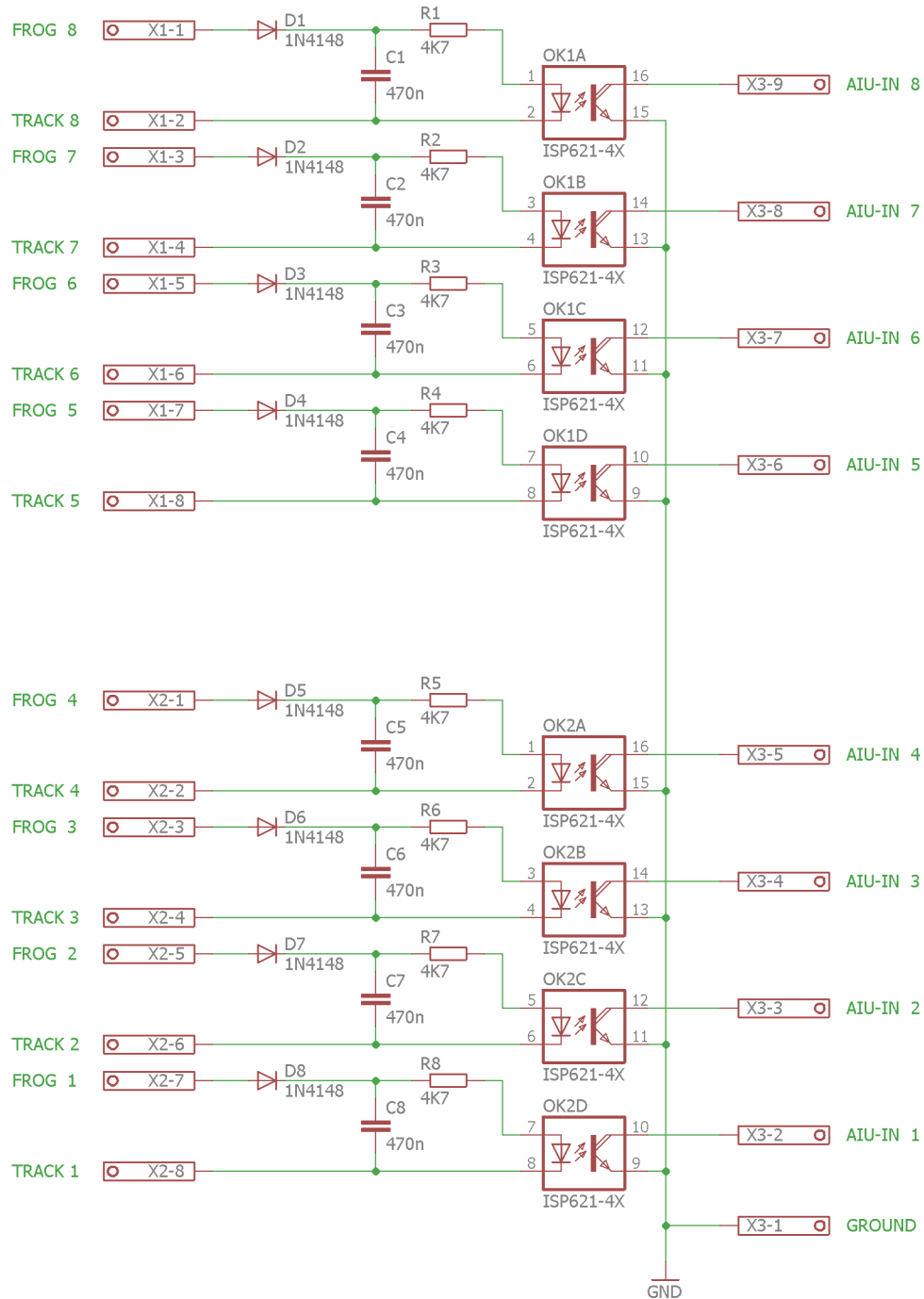

The module consists of eight independent channels. When the input terminals of a channel are connected to the DCC track voltage, as when an attached turnout is in the Route position, the input capacitor (C1 – C8) is charged via a diode (D1 – D8) to the full positive DCC voltage. This then illuminates the internal LED of the relevant section of the optocoupler (OK1A-D or OK2A-D) which in turn switches on the adjacent internal phototransistor and connects the corresponding AIU-IN output to Ground.

When no voltage is applied to the input terminal, as when an attached turnout is in the Normal position, the input capacitor discharges completely via the optocoupler internal

LED, which then ceases to be illuminated and results in the corresponding internal phototransistor switching off, disconnecting the AIU-IN output line from Ground.

If you wish to build one or more DCC-AIU Link modules, a printed-circuit board (PCB) is available from OSH Park, a small company located in Lake Oswego, Oregon. They will supply three PCBs for US\$18 including free shipping to any destination worldwide. You can see what OSH Park has to offer, and have a look at the DCC-AIU Link PCB, by following this link – [DCC-AIU Link](#).

If you then want to order a set of PCBs (in multiples of 3) click the button labelled **Order Board**, enter your e-mail address, name, and a password of your choice to establish an account with OSH Park, then follow their ordering process. You can pay either with a credit card or via PayPal. Your boards will be manufactured and delivered within two or three weeks depending on where you are in the world.

If you prefer to use an alternative PCB supplier then, instead of clicking Order Board, just click on **Download** to download a copy of the DCC-AIU Link PCB file in Eagle board (.brd) format which you can then send off to your preferred supplier.

Please note that neither A-Train Systems nor myself have any connection with OSH Park other than as a very satisfied customer of their services.

The parts required to build one DIU-AIU Link module are listed in the table below –

Part	Reference	Quantity	Value
Terminal Block, 3.5mm pitch, 2 Way		7	
Terminal Block, 3.5mm pitch, 3 Way		2	
Capacitor, Polyester, 63Volt	C1 - C8	8	470nF (0.47uF)
Diode	D1 - D8	8	1N4148
Optocoupler	OK1 - OK2	2	Isocom ISP621-4X
			Vishay K847PH
			Vishay CNY74-4H
			Broadcom ACPL-847-W00E
			Lite-On LTV-847
Resistor, Metal Film, 0.25Watt	R1 - R8	8	4K7 (4.7 K)

Notes :

1. The 8-way and 9-way Terminal Blocks are made up from the appropriate number of 2-way and 3-way parts since this is a much cheaper option than purchasing complete 8-way and 9-way blocks.
2. Any of the five options listed for the Optocouplers can be used, depending on which manufacturer's parts are available from your local supplier.

Suggested suppliers for the parts listed above are Farnell for users in the UK, or Newark for users in the USA (all part of the same company). Mouser or Digikey are

alternative sources in the USA, although their prices tend to be a little higher than Newark. Both Mouser and Digikey also have European-based operations, but still tend to have higher prices than Farnell.

The table below gives suggested part numbers for each DCC-AIU Link component from each suggested supplier. Click on the part number to view the relevant webpage with details of the part –

Part	Farnell	Newark	Mouser	Digikey
Terminal Block, 2 Way	3882615	68C9065	651-1985807	277-6043-ND
Terminal Block, 3 Way	3882627	68C9066	651-1984950	277-12400-ND
Capacitor, 470nF 63V	2429337	18AC7609	80-R82DC3470AA60J	399-8901-ND
Diode, 1N4148	2675146	05AC0533	512-1N4148	1N4148FSCT-ND
Isocom ISP621-4X	1683284			
Vishay K847PH	1469524	21H0439	782-K847PH	K847PH-ND
Vishay CNY74-4H		20H4920	782-CNY74-4H	
Broadcom ACPL-847-W00E	1339046	58Y4455	630-ACPL-847-W00E	516-3758-ND
Lite-On LTV-847			859-LTV-847	160-1370-5-ND
Resistor, 4K7 0.25W	9341951	95W7764	71-CCF074K70GKE36	S4.7KCACT-ND

Notes :

1. You may be able to source equivalent parts locally at a lower cost, using the details available for each suggested part by clicking on the links above (assuming that you have sufficient electronics knowledge to understand the specifications). However, beware of very low cost parts available from sources on eBay, for example, since these are often of low quality or may be manufacturers' substandard rejects.
2. The total cost of parts for a single DCC-AIU Link module should be less than US\$10 (UK£8), not including the additional US\$6 for the PCB, but could be as high as US\$17 if using all parts from Digikey, for example.
3. The terminal blocks account for the highest proportion of the parts cost, ranging from around 35% to as much as 75% of the total parts cost. If you wish to economise you can, of course, omit the terminal blocks entirely, and simply solder wires directly to the PCB instead.
4. Buying electronics components singly or in small quantities is much more expensive than buying in bulk (in quantities of 10 or more), so it is well worth considering carefully at the outset how many modules you might build, and then procuring all of the required components in a single purchase. This will also reduce any shipping charges.
5. If you are unsure about soldering the optocouplers into the PCB, then you could consider fitting a pair of 16-pin dual-in-line sockets to the PCB first, and then plugging the two devices into the sockets once all the rest of the soldering is done.

Once you have acquired your PCBs and a full kit of components, the next step is to start the assembly. If you do not have any experience of soldering electronic components then you should first have a look at one or two of the guides available on the Internet (such as at <https://www.makerspaces.com/how-to-solder/>) and some of the multitude of videos available on YouTube, although there is nothing to beat getting some copper stripboard from one of the component suppliers and practising soldering wires (and a few spare components) to it before tackling the real module PCB.

Use resin-cored solder in wire form only – never use solder with an acid flux (as sold for plumbing purposes) – and use a fine-tip soldering iron with a maximum power rating of 25 Watts. All joints should be made as quickly as possible to avoid damaging the PCB and components. The greatest enemy of electronics is heat.

Fit those components with least height to the PCB first, ie. the diodes and resistors, so that, when you turn the PCB over and lay it down to solder the component wires on the underside of the board, the components do not fall out of the holes. Ensure that the diodes are fitted the right way round, with the band or stripe at one end of the diode towards the centre of the PCB, as shown on the PCB markings. It does not matter which way round the resistors (or the capacitors at a later stage) are placed on the PCB.

A tip here is to solder just one wire from each component, then turn the PCB over and check that all components are still flush with the PCB. If not, make them so before soldering the remaining wire(s) of the component.

When you fit the optocouplers (as the next tallest components), ensure that the notch at one end of the package is towards the top of the PCB, again as indicated by the board markings, and that all pins are through the PCB holes, with none having been bent under the device. Solder two diagonally-opposite pins on each chip first, and then check that the device is still flat on the PCB. If not, it is easy to melt the solder on one corner pin while pushing the device down into the correct position. You can then carefully solder all of the remaining pins. Finally, fit the capacitors followed by the terminal blocks (if you decide to use them).

Carefully inspect the completed board to check that all of your soldered joints are bright and shiny, and that the solder has wicked through the PCB holes to the component side of the board. If you are uncertain of this then you can carefully apply your iron and a little extra solder to the component wires or pins on the top side of the PCB where they meet the exposed copper pads, but take care not to damage the components with the hot soldering iron. Check also that there are no solder bridges between copper pads or component pins anywhere on either side of the PCB. Use of a x5 or x10 hand lens or jeweller's loupe is highly recommended for this inspection.

To test the DCC-AIU Link module, connect it to an active AIU as shown in the diagram earlier in this Section – none of the AIU LEDs should be illuminated. Next, use a pair of wires temporarily connected to your track DCC supply to connect briefly to each pair of input connections (terminals 1 and 2, then 3 and 4, etc.). As you connect to each input pair, the corresponding AIU LED should light. If you get any sparks as you touch the DCC wires to the terminals then you have a short circuit somewhere to be eliminated.

Please note that A-Train Systems cannot offer a repair service for faulty modules although, if you request support as explained in **Section 11.2**, I will do my best to offer help and advice to sort things out.

15 A-TRACK REVISION HISTORY

Release 4.1.1

Initial release of Version 4 of A-Track for evaluation

Release 4.2.1

Communications interface to A-Track rewritten to use any COM: device or port, including a standard PC Serial Port or USB-to-Serial adapter (tested with Prolific, FTDI, Keyspan, Silicon Labs, and Microchip devices)

Interface handling extended to include NCE USB Interface, allowing use of A-Track with Power Cab and Smart Booster systems as well as Power Pro, although with reduced functionality (neither Power Cab nor Smart Booster support backup or restore, nor setting of Command Station or Cab parameters, from A-Track)

Splash screen at program start amended to show type of NCE System connected

A-Track Install and Uninstall improved to reduce possibility of program files not being removed fully during Uninstall – note that, if the user saves any files in any of the installation folders (in Program Files) then none of the user files, nor the installation folders affected, will be removed

All CV values now displayed in decimal in all windows – use of hexadecimal notation removed from all windows except CV Value edit frame

In Edit CVs windows, moving the mouse cursor over the CV values displayed in the grid will now show full description of each CV as a pop-up label

Complete revision of handling of CV ranges into Pages of 256 values, with each page split into two Blocks of 128 CVs, to accommodate complex sound decoders with Indexed CV pages. Indexing scheme used by Quantum also incorporated in a consistent manner – any Item with a Quantum decoder incorporated under Release 4.1.1 will be converted automatically to the new system of CV Blocks and Pages when edited under Release 4.2.1

Copying of CVs between Items in Edit CVs window revised to reflect new Paged structure, particularly with regard to Indexed pages

Pages Tab replaces Sound Tab in Edit CVs window to allow selection of CV range to be displayed as well as selection of decoder manufacturer (Basic, NCE, SoundTraxx, Quantum, Digitrax, MRC, LokSound)

Selection of Pages Tab in Edit CVs window extends window width to display categorised lists of all CVs specific to the selected manufacturer – selecting CV from list highlights CV in grid and opens frame to edit CV value – intended to avoid need to consult manufacturer's documentation in order to find CV number corresponding to a particular function

Read / Verify and Program facilities updated to allow selection of specific Block of CVs for access, to simplify handling of complex decoders with large ranges of CVs

Changing CV selection, or right-clicking on a CV, during Read /Verify or Program operations no longer causes the Read / Verify or Program frames to be hidden by a Parameter Tab (blocking access to the Cancel / Finish button)

Premature exit from Program operation no longer clears any remaining yellow highlights on selected CVs (ie. selected CVs which were not accessed during Program) – now consistent with Read / Verify operation

Excessive time taken to select group of CVs, or to start or exit from Program and Read/Verify operations (observed especially under Windows 7) now eliminated

Error is not now generated if address values in the Identity Tab of the Edit CVs window are entered with a leading zero

Error handling improved for entry of all numerical values so that entry of an out-of-range value will no longer result in a potentially fatal overflow error

Initialisation of frames for Bidirectional Comms and Alternate Power Source parameters is now performed correctly in the Config Tab of the Edit CVs window

Consist handling changed to prevent a Locomotive being allocated to two Consists at the same time in the same Item List

Consist handling extended in a limited fashion to Power Cab and Smart Booster systems – Consists can be activated or de-activated with such systems although it is not possible to coordinate Consist definitions between the systems and A-Track (as can be done with Power Pro)

Abandoning the creation of a Consist before it has been saved to the Item List will not now leave the selected Consist Address still allocated (error was previously generated if that Address was later selected for a new Consist)

Warning message added to advise that all assigned Locomotives must be present on the mainline track when Consists are activated or de-activated

Warning added to alert of any Items currently being edited when A-Track is closed, to allow program close to be aborted and Items saved, rather than for the open Edit CVs windows to be simply closed and any changes discarded

Opening of A-Track amended to make certain that only a single instance of A-Track can be run at any given time to prevent disruption of communications with the Command Station

Conflicts caused by accessing Command Station Status while a Cab Status Refresh operation is in progress now prevented by disabling all NCE menu functions during Cab Status Refresh

Handling of filename extensions in File Save Checked corrected to be consistent with normal File Save As operation

Minimum size set for main A-Track window to prevent generation of fatal error if window dimensions reduced below a critical point – any attempt to drag window edges to make window size less than the minimum is ignored

In Startup Tutorial, error causing restart when attempting to go Back from page 2 is now fixed – action now returns correctly to Page 1

Inconsistencies in enabling entries for Allocate, Deallocate, and Operate between Item and Pop-Up Menus – and when different types of NCE System are connected – have been corrected

NCE Cab Selection grid is now disabled during Cab Deallocate

Operate window Functions are no longer disabled if Options are accessed then closed without changing anything

Changing Operate window Options and then choosing not to update the affected Item when closing the Operate window no longer disrupts communication with the NCE Command Station

Print function extensively revised to handle new CV Page and Block structure, with added annotation of output pages

Selecting Landscape Orientation in Print Setup no longer overrides the default Portrait selection when printing Item Details

Paper Size selection in Print Setup now has no effect on the Size selection in the main Print Items window (A4 or Letter only)

With the decision to offer A-Track as a free-of-charge application, the Trial Version option (and limitations on time and usage) has been removed completely – Registration is retained with the offer of priority support for registered users – again free

Added Register Online option to Register / Activate window – this allows automatic generation and immediate delivery of an Activation Key to the user by e-mail from the A-Train Systems website – as before, after entry of Key code, the registered user's name is displayed on the start-up splash screen

Entry of the user's names in the Register / Activate window is retained in the Registry whether or not the user chooses to register or activate the program – this removes the need for the user to re-enter the names next time the window is opened – the names can be edited or deleted at any time before activation (but not after)

Added Support / Report Problems option to Help menu which gives access to a facility on the A-Train Systems website to request support or report problems by completing details on an online form

Context Help improved to display wider range of relevant Help pages when F1 key pressed at any point during A-Track operations

Malfunction of Read / Verify and Program functions when Help pages are displayed fixed by closing any open Help page before starting Read / Verify or Programs data transfers

Startup Tutorial updated to reflect changes in CV structure and editing, and to make it more robust when moving forwards and backwards, particularly where the user makes additional changes in the A-Track windows

Release 4.2.2

Corrected error which caused a program crash when the A-Track window was minimised – the implemented fix also imposes a minimum size on the main A-Track

window to prevent it being made smaller than the size required to display some key information

Release 4.3.1

Verified operation with Windows 8 – only difference is in the way the Uninstall option is accessed, due to the way Microsoft have implemented the Start Screen

A-Track can now be started by double-clicking on any saved Item List (a file with an extension of .itl) – when the program is opened in this way, the Start-Up Tutorial is not displayed, even if it is set to be shown when A-Track is run directly

When starting A-Track, a check is made to ensure that the program is not already running – if so, a warning message is displayed and program load of the second instance is abandoned

Handling of serial communications port used by A-Track to connect to the attached NCE system revised to ensure that the port is fully closed and released when A-Track is closed, so that it is then available for use by other programs

When A-Track is running, a different Item List can be loaded simply by locating and double-clicking on the required Item List in Windows Explorer – if the current Item List has been changed, you will be prompted to save it before proceeding to load the replacement Item List

The file extension .ita can now be used to indicate an Item Archive – this is intended to be used to store a number of merged Item Lists as a single file for backup purposes – an Item Archive is loaded, handled, and saved by A-Track in exactly the same way as any other Item List

For all file load and save operations (Item Lists and Backup Files), a note is kept of the last-used folder, and this folder is thereafter opened as the prospective source or destination – if changed by the user, the new folder then becomes the default

Editing of Items and all file save or load operations are now disabled when any operations involving data transfers with an NCE Power Pro Command Station are in progress, to prevent data corruption

All warning messages and prompts are now centred on the specific window to which they relate, rather than being displayed in the centre of the screen where they could be overlooked or misunderstood

Corrected error which resulted in a program crash if any of the Item List headers were clicked when no Item List was loaded

Format for saving backup files changed to be fully compatible with that defined by NCE – and as used by JMRI for Consist and Macro backup files – all backup files saved in the earlier A-Track format, or created using JMRI Decoder Pro, can be restored (loaded) to A-Track - prompt in File Save dialog changed to Backup Files (Plain Text) with a file extension of .mbk

Added Edit / Run Macros option to Edit menu to access a major program enhancement which allows Macros to be reviewed, edited, created, and run either directly from Macro Backup files (providing an extended macro facility for Power Cab systems,

equivalent to that provided by Power Pro systems) or from the set loaded within a Power Pro Command Station – or from a combination of the two sources

A description field can be added to each defined Macro as part of the Edit Macros function – descriptions saved as additional section of backup files, while retaining compatibility with NCE/JMRI file format (although cannot be loaded to Power Pro)

Reliability of data transfer process to restore Backup Files to the Power Pro improved by allowing the Command Station more time to handle each data block

Error handling when data writes from A-Track to Power Pro go wrong improved to make recovery more reliable – amended recovery instructions now displayed if such a data transfer error occurs

Added additional Consist Status option to View Menu to allow the contents of a Consist Backup file to be viewed against the Consists and Locos currently in the displayed Item List – Consists in the Backup file can be transferred to the Item List, but cannot be edited nor activated on the track

Transfer of Consist data from either the Power Pro Command Station or a Backup file can now be cancelled at any point up to the final confirmation without affecting the state of the Item List

Adjusted timing and repetition of commands sent during Consist Activation routines to improve reliability of the process, and ensure that all assigned Locomotives are programmed correctly

Corrected error where the Allocate option on the Item or PopUp menus was not properly enabled for all Items assigned to a Consist (Mult'Lead, Mult'Mid, and Mult'Rear)

Corrected setting of Edited and Not Programmed Flags for Consists and Multiples so that they are consistent with flag settings for Locomotives and Accessories

Before attempting to Activate a Consist defined in the Item List, a check is now made that an NCE Command Station is connected and operational – otherwise a warning is displayed

Added CV Descriptions and List sets for Lenz, TCS (including sound), and Broadway Paragon 2 decoders to the Edit CVs facility – a specific Decoder Manufacturer is now selected from a drop-down list on the Pages tab rather than via separate option buttons – Print routines updated to include additional descriptions / lists

Slow update of the CV Value grid, observed following changes to, or selection of, sets of CVs, cured by preventing re-display of the new grid contents until all changes are complete

Cell shading of unused CV locations on Indexed pages, for both Quantum and ESU LokSound decoders, changed to grey rather than black

Read/Verify and Program operations involving Indexed pages now ignore all unused CV locations in order to minimise the time taken

Corrected error in handling serial communications timeout errors during Program or Read/Verify operations, which left all Edit CVs controls disabled, so that the window could only be closed by closing the whole A-Track program

Timeout applied to Read/Verify operations using Direct Mode changed to 4 seconds – the longer 24 second timeout is still used in Paged, Register, or Address Modes – this speeds up Read/Verify when no response is received from the Command Station for any reason when attempting to read the value of a CV

File security settings in Windows Vista, 7 and 8 can generate a serious error when Start-Up Tutorial attempts to save a modified Item List back to the folder in Program Files holding the example Item Lists – solved by copying tutorial Item List to a new folder in user's Documents area, and directing all subsequent file saves to this area

Start-Up Tutorial expanded to cover the creation of a first Item List and copying the contents of decoders fitted in the user's roster of locomotives to Items in the new Item List

Before opening an Item List from the MRU list on the File menu, a check is now made to verify that the file still exists (not deleted or moved) – and display a warning if the file cannot be located

Open Merge option on File menu now only enabled when an Item List has been loaded

Fixed inconsistencies in numbering new Blank Items after a new Item List is opened

A filename including today's date is now suggested when saving a newly-created Item List

When saving a merged set of Item Lists, a new filename including today's date is now suggested instead of the filename of the first Item List loaded

Corrected an error which prevented the user choosing the file extension (.itl or .ita) to be added to the filename when saving an Item List

If user clicks SaveChecked without any Items being checked, an error message is now displayed rather than simply ignoring the action

Corrected error where MRU file list on File menu was not updated and saved to Registry when A-Track was closed

Filename paths shown in MRU list on the File menu are now truncated to 60 characters maximum to avoid the width of the File menu increasing excessively

Fixed error where File / Close was not always enabled after an Item List was loaded

The automatic scan of the status of all connected Cabs when using a Power Pro system (every 6 minutes) can now be suspended via an additional option provided when the Refresh Item Allocation & Status entry is selected from the View menu – selecting the View menu entry again gives you the option to resume scans – state of this option is saved in the Registry so that it remains in force each time A-Track is started, until cancelled by the user

Register and Support forms amended to display details of the Windows version in use together with details of the A-Track version and the type of NCE equipment connected, and to send this data to the relevant A-Train Systems webpages for onward

transmission – having this information greatly assists in providing support and solving reported problems

Major enhancements made in the handling of Accessory decoders to accommodate the modern practice of using Operations Mode programming to set their parameters, rather than connecting to a Program Track – features added to handle parameters specific to the NCE range of Accessory decoders – any Accessory Items defined in Item Lists using previous versions of A-Track will be automatically updated to use the new format when accessed

Addresses for Accessory decoders now displayed in a four digit format, with Decoder and Output Addresses identified separately for each Accessory decoder – Output Addresses derived from current Decoder Address in accordance with NMRA Recommended Practice RP9.2.2 now shown on Config tab in the Edit CVs window for Accessories – with decoders where Output Addresses can be individually programmed, these addresses now displayed on separate Addr's tab

When displaying the Item List using Details view, Accessory addresses are now shown with the Decoder Address in the Primary Address column, and the currently-selected Output Address in the Extended Address column

Following a suggestion from Dave Cooper, format of the on-screen Operate controller improved to allow Locomotive speed to be changed by simply clicking on the relevant part of the Speed disc (rather than drag the pointer with the mouse) – this also avoids display of the spurious “mouse trails” generated under Windows 7 and 8

Added set of four Speed Increment / Decrement buttons to the on-screen Operate controller to emulate use of keyboard Up/Down Arrow and PageUp / PageDown keys in changing speed settings

Speed Table values (under the Speed tab in the Edit CVs window) can now be incremented or decremented by clicking above or below the relevant marker rather than by just dragging the marker with the mouse – again avoids display of the spurious “mouse trails” generated under Windows 7 and 8

Any changes made to Speed Table values, before they are saved, can now be cancelled by pressing the Esc (Escape) key – the Speed Table is then re-displayed using the values currently held in the Item's CVs

Implemented version of the on-screen Operate controller for Accessories to allow control of up to eight turnouts, each with a separate Output Address – controller also incorporates facility to perform direct Operations Mode programming of Accessory decoder parameters

When used with a Power Pro system, the Accessory Operate controller makes use of the Turnout Monitoring data available from the Command Station (state of turnout according to last command sent) – with Power Cab, or with no NCE system connected, details of the last command sent to each turnout is maintained within the Accessory Item

The Turnout Monitoring data available from the Power Pro can be used by the on-screen Operate controller for any Accessory to check on the current state of any turnout decoder address (according to last command sent)

State of Accessory outputs is now shown in the Function column of the Item List when using the Details view

Prompt to save changed Operate Options, shown when either a Locomotive or Accessory Operate window is closed, now shows the correct Item Number

Updated Print routines to handle full details of revised Accessory Items

Corrected display of CV Block Select checkboxes in Print setup form – checkboxes now enabled correctly, and consistent with other selection options, when Print facility opened

Serious error in Command Station Setup, where cancelling the Power On Reset or System Factory Reset process at any point would leave the Setup window with all controls disabled (so that neither the window nor the A-Track program could be closed), now corrected – abandoning either operation at any point returns the user to the Setup window with all controls re-enabled

Wording of System Factory Reset warning message reformatted to improve clarity

The version of USB Interface used to connect to a Power Cab or Smart Booster system is now reflected in the icon displayed on the A-Track status bar – those for USB Interface V6 remain as before, whereas those for USB Interface V7 show a number to reflect the jumper settings (0 to 7)

Release 4.3.2

Following reports from several users of the Startup Tutorial failing to run, corrected error in specifying the path names for the various Tutorial files

Corrected serious error which resulted in a program crash (fatal error 13) if the user attempted to access either of the Register or Support options from the Help menu if A-Track had never been connected to an NCE system

The automatic scan of the status of attached Handheld Cabs every 6 minutes will no longer be enabled by default, in order to avoid interference with data transfer operations to and from the Command Station, such as when Restoring from a Backup File or in the course of using the Edit / Run Macros facility. The user still has the option of enabling the automatic re-scan via the View menu

Timing of data transfers between Power Pro and A-Track revised, with particular regard to Restore operations and Command Station Setup, in order to improve reliability and reduce the number of failed transfers

Fixed handling of locomotive headlight commands when using an on-screen controller (Operate) in response to a fault report from Dave Cooper where the reverse headlight comes on when loco is stopped in a forward direction with the front headlight on – forward and reverse headlights now operate as expected

Following a suggestion from Dave Cooper, extra options have been added to the Operate window to set the size of step for the speed increment and decrement buttons, and for each click on the 'speed disc', in terms of speed-dial divisions (equivalent to rotation angles) – four step values are now available for each of Minor (0.1, 0.2, 0.3, 0.4), Major (0.5, 1.0, 1.5, 2.0), and Speed Disc Click (1.0, 1.5, 2.0, 2.5) Steps – selected step values are stored in the Item to which they apply

In response to a request from Tony Leighton, MTH have been included in the list of Decoder Manufacturers, together with the corresponding lists of manufacturer-specific CVs for their Proto-Sound 3 decoders

Users can now view the COM port and baud rate in use by the serial link to the Power Pro or USB Interface, by moving the mouse cursor over the COM indicator at the righthand end of the status bar, and the NCE software version by similarly hovering over the NCE indicator, following a suggestion from Tony Swanborough

Release 4.4.1

Expanded all program functions to handle the extended facilities provided by the release of NCE Version 1.65 Power Cab and Smart Booster systems, and the DCC Twin starter system. These systems, via the NCE Version 7 USB Interface, allow access to all Command Station parameters including Handheld Cab setups, Consists and Macros, as previously possible with NCE Power Pro systems, and permit full backups of all settings to be made and saved to file on your PC

Although A-Track can update all system parameters of NCE Version 1.65 Power Cab, Smart Booster, and DCC Twin systems, including assignments of Locos and Consists, such changes are not retained by the NCE systems after power-down, so a facility added to completely restore saved system parameters automatically when A-Track starts (if required by the user)

Full details of connected NCE system now available by hovering mouse cursor over status indicators (bottom left of A-Track window)

Corrected problem reported by Jim Ayres and several other users that A-Track will not connect to NCE system after Windows operating system updated (such as Windows 7 to Windows 10), a process which corrupts some A-Track keys in the Registry. Although A-Track will now continue to connect, and remain fully functional, the previous registration and activation will no longer be valid, so affected users are requested to re-register.

Added facility to check A-Train Systems website automatically or manually for updates to A-Track – options to check every time program starts, at fixed intervals, or never

Added facility to handle connection of NCE Auxiliary Input Units (AIUs) and specifically their use to monitor turnout positions

Since AIUs connect to the Cab Bus and use Cab Addresses, the status of any connected AIU is now available when accessing the existing NCE Handheld Cab Status facility (NCE menu)

Changed the way all connected NCE equipment is scanned to reduce interference with user operations – all connected Cabs, AIUs, etc. are scanned when A-Track starts (or whenever an Item List is loaded) and then each connected device is polled in sequence for its current status every 2 seconds, as a background task, rather than performing a complete (and disruptive) full scan every 6 minutes – has the added advantage that the status of the connected hardware is available in near real-time

Added text to Status Bar during Cab Scan to show which Cab is currently being scanned and keep the user fully informed

DCC commands from different sections of the program are now handled centrally instead of being output independently – this has markedly reduced the number of command and data transfer failures which occur

Completely revised handling of Macros to be consistent with the capabilities of all types of NCE system, to improve editing, and to streamline the output of Macro commands – all available 256 Macros now held in a single table – keyboard shortcuts available to perform major operations

Added facility to create and edit Mimic diagrams which represent the structure of a user's layout in graphical form on screen, showing the directions set for all turnouts and allowing turnouts to be operated directly from the screen with a mouse – if AIUs are connected then the Mimic diagrams will be updated automatically to show the actual layout configuration at all times

Editing of Mimics fully supported by ability to cut and paste blocks of track elements as well as single elements, together with a comprehensive Undo/Redo facility

Mimics support a Find Route capability to determine whether a direct route exists between specified start and end points via an optional mid point – any route found will be one which requires the minimum number of turnouts to be set, and the route can be set with a single keystroke / click – with an option to save the route as a Macro – Find Route handles complex layouts including both normal and reversing loops

Options provided to execute key Mimic operations with single mouse clicks or taps on a touch-sensitive screen without requiring simultaneous use of Ctrl (Control) or Shift keys

Included Print option to print image of Mimic panels either to paper or to file – any installed printer can be selected to receive output

Operation of on-screen controllers for Loco Items streamlined to use the mousewheel to control locomotive speed, rather than having to click on specific screen buttons or segments of a graphical 'speed knob' – new option to display speed for Loco Item in Item List as either a speed-step value or as a percentage of maximum (both formats shown below 'speed knob') – controller now shows Loco (or Consist) Address in title bar

Title bar of EditCVs window now shows active Address of Item being edited – where a Loco is assigned to a Consist (Multiple), the Address of the Consist is also shown

Use of mousewheel enabled to allow setting of points on graphical speed curves within the EditCVs window, replacing the previous drag-and-drop mechanism which does not work correctly under Windows 10

Mousewheel can now be used to provide rapid scrolling through the full 256-entry Route Macro table

Definition of turnout parameters in EditCVs window for Accessory decoders expanded to allow individual decoder outputs (and hence turnouts) to be given meaningful names, and for pairs of turnouts to be linked so that they can be switched (in the same or opposite directions) with a single command

Added facility to allow two turnouts to be driven from a single Accessory output (where the output has the necessary power required) but retaining the capability to monitor

the position of each of the turnouts independently via connected Auxiliary Input Units (AIUs) and Mimic diagrams

Changes to the internal data structure of Accessory Items will require Accessory Items and/or Item Lists created with an earlier release of A-Track to be updated whether or not such Items have been currently edited by the user – a prompt to do this is displayed when A-Track is closed

Added facility to define and edit the allocation of specific turnouts to each connected Auxiliary Input Unit (without reference to the Accessory Decoder used to control the turnouts) – the saved definition file can be loaded automatically, if previously requested by the user, when A-Track starts

Accessory Operate window (on-screen controller) expanded to provide a facility to program Accessory addresses and, where AIUs are fitted, to report the current status of any Accessory output (turnout) on the layout

Operate window (on-screen controller) functions for both Loco and Accessory Items can now be operated via shortcut keys as well as mouse clicks (applies to Operate window which is currently selected or active)

The last-selected Item List can now be set to be loaded automatically by A-Track at start-up – in addition to the current facility of being able to double-click on any saved Item List file in order to start A-Track with that Item List loaded

Introductory Tutorial revised and expanded to cover additional Route and Mimic facilities, with suitable example files for demonstration

To avoid Windows security issues with attempting to run demonstration Item Lists from where they are installed in the Program Files (x86)\A-Track\Example_Item_Lists system folder, A-Track will now copy all the demonstration files to a new folder (A-Track Item Lists) created in the user's Documents area from where they can be opened and updated without problems

All Decoder CV Lists from all manufacturers updated in accordance with latest published data – extra Indexed Pages added to SoundTraxx (none previously) and to LokSound and Quantum – Zimo added to list

Added extra checkbox to relevant pages under EditCVs Pages frame to allow hidden Not Used CVs for SoundTraxx and LokSound decoders to be read, viewed and programmed (otherwise skipped)

Accessory Decoder functions updated to handle NCE Mark 2 decoders with different CV locations re subsidiary setting like pushbutton inputs, output toggle, and output polarity – including addition of QSnap-Mk2 with four outputs

Program or Verify Mode (Paged, Direct, Register, Address) and related options are now retained and reapplied the next time the Program or Read/Verify facilities are used, following a suggestion by John Scanlon

Assignment of Locos to Consists can optionally be set to adjust automatically so that the Consist always has a Lead Loco, and a Rear Loco if two or more Locos in the Consist, regardless of the position in the Consist (Lead, Mid, or Rear) to which any Loco is initially assigned – if not set, Locos remain in their assigned positions

Emergency Stop operation modified to accommodate Version 1.65 Power Cab, Smart Booster, and DCC Twin – unlike Power Pro, the Command Station with these systems cannot be commanded to remove power permanently from the mainline track, so the Emergency Stop operation is much less effective

Print options extended to include Route Macro lists and AIU Allocations, and printout of Accessory Item Details now includes linked turnouts – selection of any installed printer to receive output simplified without use of the Print Setup dialog (which never worked properly)

Printing to a file where the file extension is set to anything other than .rtf or .csv will generate the file in plain text format (as with a .txt extension) rather than the previous default Print to File format of Real Text (.rtf)

Register and Support forms now display the Command Station type and firmware version and the version of USB Interface connected where appropriate

Checks added to ensure that all background processes are closed completely before A-Track finishes its shut-down process

16 A-TRACK END-USER LICENCE AGREEMENT

A-Track for Windows
 Copyright 2007-2019 JT Chamberlain, A-Train Systems
 All rights reserved.
 www.a-train-systems.co.uk

IMPORTANT - READ CAREFULLY:

This licence agreement is a legal agreement between you (individual or legal entity) and JT Chamberlain (trading as A-Train Systems)

YOU AGREE TO BE BOUND BY THE TERMS OF THIS LICENCE AGREEMENT AND THE LIMITATIONS OF YOUR LICENCE BY INSTALLING, COPYING, DISTRIBUTING OR OTHERWISE USING A-Track for Windows. IF YOU DO NOT AGREE, DO NOT INSTALL, DISTRIBUTE, OR USE A-Track for Windows IN ANY WAY.

VIEW THIS ENTIRE LICENCE AGREEMENT BY SCROLLING DOWN, USING THE SCROLL BAR ON THE RIGHT, OR BY PRESSING THE UP/DOWN ARROW KEYS AND/OR THE PageUp / PageDown KEYS.

THIS PRODUCT (COMPRISING SOFTWARE AND ALL ACCOMPANYING DOCUMENTATION) IS THE PROPERTY OF A-TRAIN SYSTEMS. THE A-Track for Windows APPLICATION IS MADE AVAILABLE TO YOU, THE END USER, SUBJECT TO THE FOLLOWING LICENCE AGREEMENT. PLEASE READ THIS LICENCE AGREEMENT CAREFULLY BEFORE INSTALLING OR USING THE PRODUCT.

A COPY OF THIS LICENCE AGREEMENT IS AVAILABLE FOR YOUR FUTURE REFERENCE IN THE "A-Track-LicenceAgreement.rtf" FILE PROVIDED WITH THE INSTALLED PRODUCT.

TABLE OF CONTENTS

1. Definitions
2. Warning
3. Ownership
4. Grant of licence
5. Restrictions and limitations of use
6. Termination of licence
7. Maintenance, support and updates
8. Confidentiality
9. Disclaimer
10. Limited liability
11. Distribution
12. Reservation of rights

1. DEFINITIONS

"A-Track for Windows " means the A-Track for Windows software and everything included in its official distribution packages, such as the documentation, example files and all other modules and applications.

"A-Train Systems" means JT Chamberlain trading as A-Train Systems.

"official distribution package" means a packaged set-up file, in the form of an executable installation program containing A-Track for Windows, which is available on portable media or through a file download from a designated page on the A-Train Systems website at www.a-train-systems.co.uk, or other authorised source.

"licence agreement" means this text document. This licence agreement is a legal agreement between you (individual or legal

entity) and A-Train Systems. You must accept all the terms and limitations in this licence agreement if you wish to use, run, or copy A-Track for Windows in any way.

"licence" means a legal right to use A-Track for Windows. A licence must be acquired by download or purchase of a copy on removable media of the A-Track for Windows software product.

2. WARNING

A-Track for Windows is protected by copyright laws and international copyright treaties as well as other intellectual property laws and treaties. Unauthorised reproduction or distribution of the A-Track for Windows product, or any portion of it, may result in criminal and civil penalties, and will be prosecuted to the maximum extent possible under law.

3. OWNERSHIP

A-Track for Windows is proprietary to A-Train Systems. The product is licensed, not sold, to you notwithstanding any reference herein to "purchases".

You acknowledge and agree that:

- a. A-Track for Windows is protected by copyright laws and international copyright treaties as well as other intellectual property laws and treaties.
- b. A-Train Systems retains all copyrights and other intellectual property rights in A-Track for Windows.
- c. There are no implied licences under this Licence, and any rights not expressly granted to you hereunder are reserved by A-Train Systems.
- d. You acquire no ownership or other interest (other than your licence rights) in or to A-Track for Windows software.
- e. A-Train Systems owns all copies of the A-Track for Windows software product, regardless of how they have been made or distributed.

4. GRANT OF LICENCE

A-Train Systems is only willing to grant you these rights if you obtained A-Track for Windows from A-Train Systems or an A-Train Systems authorised distributor. If you obtained A-Track for Windows from any other source you may not install or use the A-Track for Windows product.

A-Train Systems grants you the following rights provided that you comply with all terms and conditions of this Licence Agreement:

- a. Usage. You may install, use, access and run A-Track for Windows on any number of computers which are personally owned by yourself.
- b. Privacy. A-Train Systems has not implemented any mechanism, protocol, method or algorithm ("spyware") within A-Track for Windows which would collect sensitive information from your computer and then would automatically send the information to A-Train Systems without your knowledge or permission.
- c. Basic Security. A-Train Systems has not implemented any mechanism, protocol, method or algorithm ("trojan " or "backdoor") which would allow A-Train Systems to take full control of your computer without your knowledge or permission.

5. RESTRICTIONS AND LIMITATIONS OF USE

You are NOT allowed to:

- a. Modify, reverse engineer, decompile, disassemble or otherwise attempt to reconstruct or discover the source code, or any parts of it, or discover or reconstruct any mechanism, algorithm or protocol from the binary files which comprise the software of the A-Track for Windows product.
- b. Reverse engineer or otherwise attempt to reconstruct or discover the source code, or any parts of it, or discover or reconstruct any mechanism, algorithm or protocol from the A-Track for Windows product, by running any kind of special monitoring software, such as registry analysis software, or hardware monitoring devices, or other such tools.
- c. Create derivative works based on A-Track for Windows such as incorporating A-Track for Windows in a commercial product or service without a proper licence.
- d. Rent, lease, sublicense, convey, distribute or otherwise transfer rights to A-Track for Windows without written permission from A-Train Systems.
- e. Remove any product identification, copyright, proprietary notices or labels from A-Track for Windows product.
- f. Distribute A-Track for Windows in any other form than in the official distribution packages without written permission from A-Train Systems.
- g. Use, run, copy, distribute or store A-Track for Windows in your computer if this licence agreement is violated in any way.

6. TERMINATION OF LICENCE

A-Train Systems has the right to terminate this licence if you do not abide by the terms and conditions of this licence, in which case you must destroy all copies of A-Track for Windows and all of its component parts.

7. MAINTENANCE, SUPPORT AND UPDATES

A-Train Systems is under no obligation to maintain, support or update A-Track for Windows in any way, or to provide updates or error corrections.

However, if you have registered as a user of A-Track for Windows, A-Train Systems will make all reasonable efforts to provide technical assistance and to resolve any problems which you report.

8. CONFIDENTIALITY

Licensed versions of A-Track for Windows and their contents are confidential. You agree to take adequate steps to protect A-Track for Windows from unauthorised disclosure or use.

You agree that you will not disclose internal details of the licensed version of A-Track for Windows, or of any parts of it, to any third party.

9. DISCLAIMER

A-Train Systems expressly disclaims all warranties, whether express, implied or statutory, including, without limitation, the implied warranties of merchantability, of fitness for a particular purpose, non-infringement of third party intellectual property rights, and any warranty that may arise by reason of trade usage, custom, or course of dealing. Without limiting the foregoing, you acknowledge that A-Track for Windows is provided "as is" and that A-Train Systems does not warrant that A-Track for Windows will run uninterrupted or error free nor that A-Track for Windows will operate with hardware and/or software not provided by A-Train Systems. This disclaimer of warranty constitutes an essential part of the agreement. Some states do not allow the exclusion of implied warranties, so the above exclusion may not apply to you, and you may have other rights, which vary from state to state.

10. LIMITED LIABILITY

The entire risk as to results and performance of A-Track for Windows is assumed by you. Under no circumstances will A-Train Systems or its licensors be liable for any direct or special, indirect, incidental, exemplary or consequential damages of any kind or nature whatsoever, whether based on contract, warranty, tort (including negligence), strict liability or otherwise, arising out of or in any way related to A-Track for Windows or this agreement, even if A-Train Systems or its licensors have been advised of the possibility of such damage or if such damage could have been reasonably foreseen, and notwithstanding any failure of essential purpose of any exclusive remedy provided in this agreement. Such limitation on damages includes, but is not limited to, damages for loss of goodwill, lost profits, loss of data or software, work stoppage, computer failure or malfunction or impairment of other goods. In no event will A-Train Systems or its licensors be liable for the costs of procurement of substitute software or services. In addition, in no event will the total liability of A-Train Systems in connection with this agreement or A-Track for Windows exceed the actual amount paid to A-Train Systems, if any, for A-Track for Windows giving rise to the claim. You acknowledge that A-Track for Windows is not designed or licensed for use in on-line equipment in hazardous environments such as operation of nuclear facilities, aircraft navigation or control, or life-critical applications. A-Train Systems expressly disclaims any liability resulting from use of A-Track for Windows in any such on-line equipment in hazardous environments and accepts no liability in respect of any actions or claims based on the use of A-Track for Windows in any such on-line equipment in hazardous environments by you. For the purposes of this paragraph, the term "life-critical application" means an application in which the functioning or malfunctioning of A-Track for Windows may result directly or indirectly in physical injury or loss of human life.

11. DISTRIBUTION

You are not allowed to include A-Track for Windows in any commercial CD-ROM or DVD software collection without written permission from A-Train Systems.

A-Train Systems reserves the right to prevent you from distributing A-Track for Windows even if you have not violated this licence agreement.

12. RESERVATION OF RIGHTS

A-Train Systems reserves all rights not expressly granted to you in this licence agreement.

YOU AGREE TO BE BOUND BY THE TERMS OF THIS LICENCE

AGREEMENT AND THE LIMITATIONS OF YOUR LICENCE BY
INSTALLING, COPYING, DISTRIBUTING OR OTHERWISE USING
A-Track for Windows. IF YOU DO NOT AGREE, DO NOT INSTALL,
DISTRIBUTE, OR USE A-Track for Windows IN ANY WAY.

A-Track for Windows
Copyright 2007-2019 JT Chamberlain, A-Train Systems
All rights reserved.
www.a-train-systems.co.uk

Licence Agreement version 2.03

[End of this document]